



**THE DATASHEET OF  
SPK0641HT4H-1**



# Digital SiSonic™ Microphone With Multiple Performance Modes

The SPK0641HT4H-1 is a miniature, high-performance, low power, top port silicon digital microphone with a single-bit PDM output. Using Knowles' proven high performance SiSonic™ MEMS technology, the SPK0641HT4H-1 consists of an acoustic sensor, a low noise input buffer, and a sigma-delta modulator. These devices are suitable for applications such as cellphones, smart phones, laptop computers, sensors, digital still cameras, portable music recorders, and other portable electronic devices where excellent wideband audio performance and RF immunity are required. The high Signal-to-Noise Ratio (SNR) of the SPK0641HT4H-1 enhances the performance of far-field applications and many complex, multi-microphone algorithms. In addition, the SPK0641HT4H-1 offers multiple performance modes.

## Product Features

- Low Distortion of 2.2% at 115dB SPL
- Signal-to-Noise Ratio of 64.5dB(A)
- Flat Frequency Response 20 - 20kHz
- High Drive Capability
- Low Current Consumption of 230uA in Low-Power Mode
- RF Shielded
- PDM Output
- Supports Dual Multiplexed Channels
- Ultra-Stable Performance
- Standard SMD Reflow
- Omnidirectional
- Sensitivity Matching
- Standard 4x3x1 package size

## Typical Applications

- Portable electronics
- Cellphones
- Laptop Computers
- Tablets
- Digital Still Cameras
- Portable Music Recorders

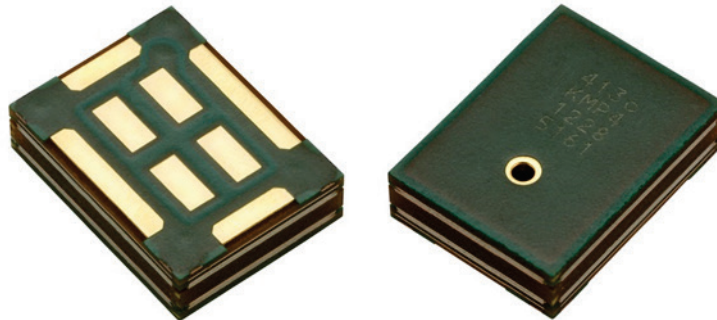

## Absolute Maximum Ratings

Table 1: Absolute Maximum Ratings

Parameter	Absolute Maximum Rating	Units	Parameter	Absolute Maximum Rating	Units
Vdd, DATA to Ground	-0.3, +5.0	V	Input Current	±5	mA
CLOCK to Ground	-0.3, +5.0	V	Short Circuit to/from DATA	Indefinite to Ground or Vdd	sec
SELECT to Ground	-0.3, +5.0	V	Temperature	-40 to +100	°C

Stresses exceeding these “Absolute Maximum Ratings” may cause permanent damage to the device. These are stress ratings only. Functional operation at these or any other conditions beyond those indicated under “Acoustic & Electrical Specifications” is not implied. Exposure beyond those indicated under “Acoustic & Electrical Specifications” for extended periods may affect device reliability.

## Acoustic & Electrical Specifications<sup>1</sup>

Table 2: General Microphone Specifications

Test Conditions: 23±2°C, 55±20% R.H., Vdd=1.8V, Fclock=2.4MHz, SEL grounded, no load, Tedge<3ns unless otherwise indicated

Parameter	Symbol	Conditions	Min	Typ	Max	Units
Supply Voltage	Vdd		1.6	1.8	3.6	V
DC Output		Fullscale = ±100	-	0	-	% FS
Directivity			Omnidirectional			
Polarity		Increasing sound pressure	Increasing density of 1's			
Data Format			½ Cycle PDM			
Short Circuit Current	Isc	Grounded DATA pin	1	-	20	mA
Output Load	Cload		-	-	140	pF
Fall-asleep Time <sup>3,4</sup>		Fclock < 250 kHz	-	-	10	ms
Wake-up Time <sup>3,5</sup>		Fclock ≥ 350kHz	-	-	15	ms
Power-up Time <sup>3</sup>		Vdd ≥ V(min)	-	-	50	ms
Mode Change Time <sup>3</sup>			-	-	10	ms

Table 3: Performance Mode Microphone Specifications

Test Conditions: 23±2°C, 55±20% R.H., Vdd=1.8V, Fclock=2.4MHz, SEL grounded, no load, Tedge<3ns unless otherwise indicated

Parameter	Symbol	Conditions	Min	Typ	Max	Units
Clock Frequency	Fclock		1.000	-	4.800	MHz
Supply Current <sup>2</sup>	Idd	Vdd = 1.8V	-	630	710	µA
Supply Current <sup>2</sup>	Idd	Vdd = 3.6V	-	700	800	µA
Sensitivity	S	94 dB SPL @ 1 kHz	-27	-26	-25	dBFS
Sensitivity Drop		Vdd(min) < Vdd < Vdd(max)	-	-	±0.25	dB
Signal to Noise Ratio	SNR	94 dB SPL @ 1 kHz, A-weighted	-	64.5	-	dB(A)
Total Harmonic Distortion	THD	94 dB SPL @ 1 kHz, S = Typ	-	0.1	-	%
Total Harmonic Distortion	THD	115 dB SPL @ 1 kHz, S = Typ	-	2.2	-	%
Acoustic Overload Point	AOP	10% THD @ 1 kHz, S = Typ	-	120	-	dB SPL
Low Frequency Roll-Off	LFRO	3 dB below 1 kHz Sensitivity	-	35	-	Hz
Power Supply Rejection Ratio	PSRR	200 mVpp sinewave @ 1 kHz	-	70	-	dBV/FS
Power Supply Rejection	PSR + N	100mVpp square wave @ 217 Hz, A-weighted	-	-90	-	dBFS(A)

Table 4: Low-Power Mode Microphone Specifications

Test Conditions: 23±2°C, 55±20% R.H., Vdd=1.8V, Fclock=768kHz, SEL grounded, no load, Tedge<3ns unless otherwise indicated

Parameter	Symbol	Conditions	Min	Typ	Max	Units
Clock Frequency	Fclock		350	-	800	kHz
Supply Current <sup>2</sup>	Idd	Vdd = 1.8V	-	230	275	µA
Supply Current <sup>2</sup>	Idd	Vdd = 3.6V	-	270	330	µA
Sensitivity	S	94 dB SPL @ 1 kHz	-27	-26	-25	dBFS
Sensitivity Drop		Vdd(min) < Vdd < Vdd(max)	-	-	±0.25	dB
Signal to Noise Ratio	SNR	94 dB SPL @ 1 kHz, A-weighted (20 Hz – 8 kHz)	-	64	-	dB(A)
Total Harmonic Distortion	THD	94 dB SPL @ 1 kHz, S = Typ	-	0.2	-	%
Acoustic Overload Point	AOP	10% THD @ 1 kHz, S = Typ	-	120	-	dB SPL
Low Frequency Roll-Off	LFRO	3 dB below 1 kHz Sensitivity	-		-	Hz
Power Supply Rejection Ratio	PSRR	200 mVpp sinewave @ 1 kHz	-	75	-	dBV/FS
Power Supply Rejection	PSR + N	100mVpp square wave @ 217 Hz, A-weighted	-	-91	-	dBFS(A)

Table 5: Sleep Mode Microphone Specifications

Test Conditions: 23±2°C, 55±20% R.H., Vdd=1.8V, Fclock<250kHz, SEL grounded, Tedge<3ns, no load, unless otherwise indicated

Parameter	Symbol	Conditions	Min	Typ	Max	Units
Clock Frequency	Fclock		0	-	250	kHz
Sleep Current	Isleep	Fclock = 0 Hz, Vdd = 1.8V	-	26	-	µA
Sleep Current	Isleep	Fclock = 0 Hz, Vdd = 3.6V	-	26	-	µA

Table 6: Microphone Interface Specifications

Parameter	Symbol	Conditions	Min	Typ	Max	Units
Logic Input High	Vih		0.7xVdd	-	3.6	V
Logic Input Low	Vil		-0.3	-	0.3xVdd	V
Low→High Threshold	VI-h		0.55xVdd		0.7xVdd	V
High→Low Threshold	Vh-l		0.3xVdd		0.45xVdd	V
Hysteresis Width	Vhyst		0.1xVdd	-	0.29xVdd	V
Logic Output High	Voh	I <sub>OUT</sub> = 2 mA	Vdd-0.45	-	-	V
Logic Output Low	Vol	I <sub>OUT</sub> = 2 mA	-	-	0.45	V
SELECT (high)			0.7xVdd	-	3.6	V
SELECT (low)			-0.3	-	0.3xVdd	V
Clock Duty Cycle			40	-	60	%
Clock Rise/Fall Time	Tedge		-	-	13	ns
Delay Time to Data Line Driven	Tdd		18	-	-	ns
Delay Time to High Z <sup>6</sup>	Tdz		3	-	16	ns

<sup>1</sup> Sensitivity and Supply Current are 100% tested.

<sup>2</sup> Idd varies with Cload according to: ΔIdd = 0.5\*Vdd\*ΔClload\*Fclock.

<sup>3</sup> Valid microphone states are: Powered Down Mode (mic off), Sleep Mode (low current, DATA = high-Z, fast startup), Low-Power Mode (low clock speed) and Performance Mode (normal operation)

<sup>4</sup> Time from Fclock < 250 kHz to Isleep specification is met when transitioning from Active Mode to Sleep Mode.

<sup>5</sup> Time from Fclock ≥ 350kHz to all applicable specifications are met when transitioning from Sleep Mode to Active Mode.

<sup>6</sup> Thold is dependent on Clload.

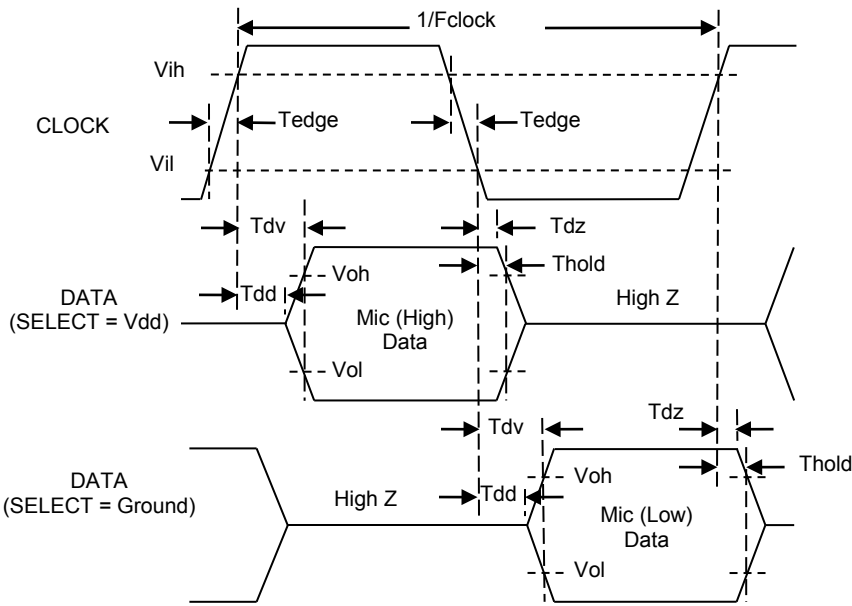

Figure 1: Timing Diagram

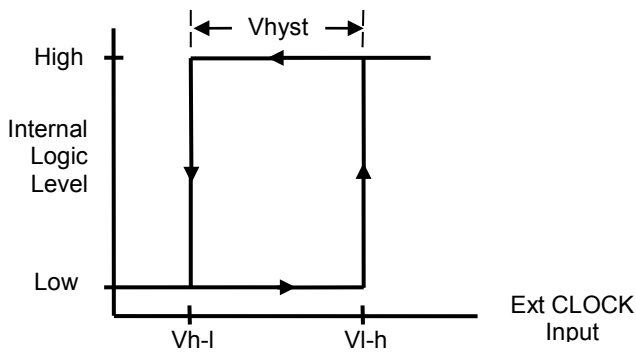

Figure 2: Hysteresis Diagram

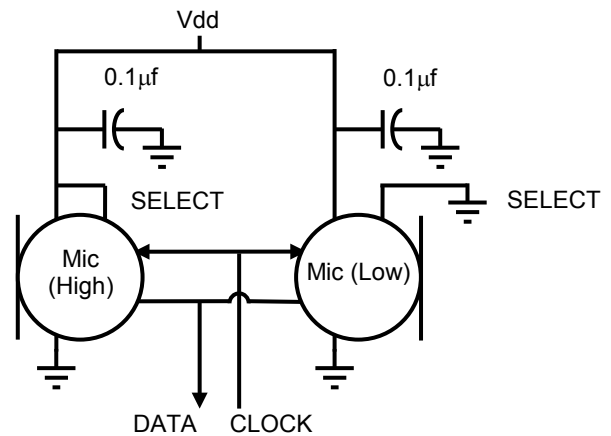

Figure 4: Typical Application Circuit

Notes: All Ground pins must be connected to ground.

Bypass capacitors should be placed next to each microphone's Vdd pin for best performance.

Capacitors near the microphone should not contain Class 2 dielectrics due to their piezoelectric effect.

Detailed information on acoustic, mechanical, and system integration can be found in the latest *SiSonic™ Design Guide* application note.

Microphones which share common clock and data lines must also share a common power source.

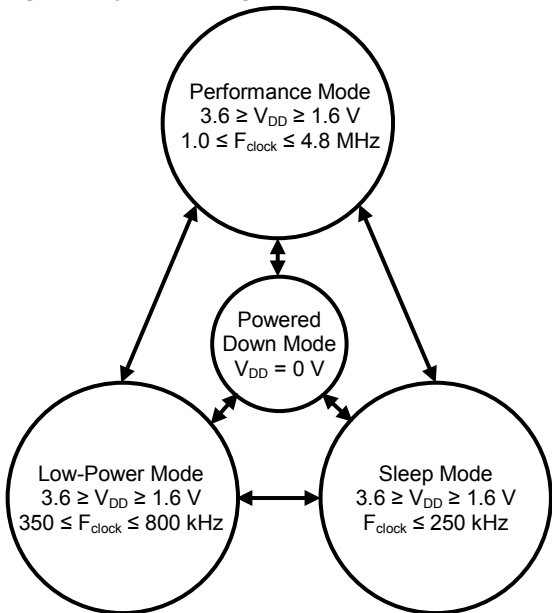

Figure 3: State Diagram

Microphone	SELECT	Asserts DATA on	Latch DATA on
Mic (High)	Vdd	CLK rising edge	CLK falling edge
Mic (Low)	Ground	CLK falling edge	CLK rising edge

Table 7: SELECT Functionality

## Performance Curves

Test Conditions: V<sub>dd</sub>=1.8V, F<sub>s</sub> = 2.4MHz, no load, unless otherwise indicated

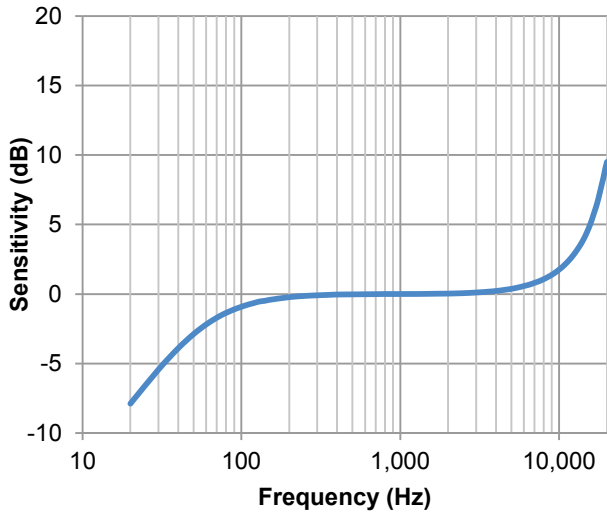

Figure 5: Typical Free Field Response Normalized to 1 kHz

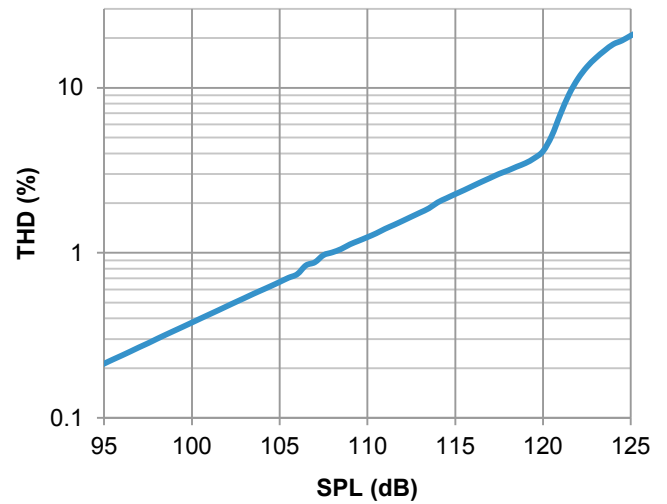

Figure 8: Typical THD vs SPL

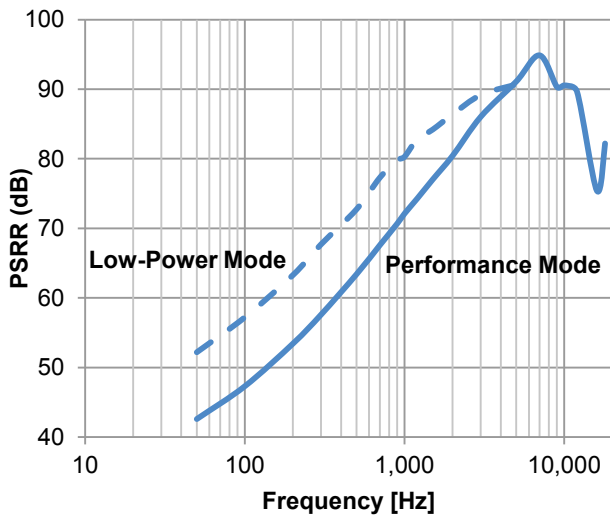

Figure 6: Typical PSRR

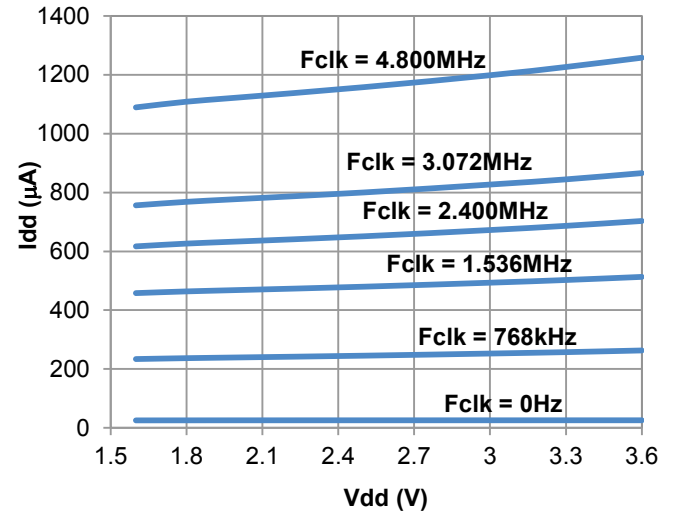

Figure 9: Typical Free Field Response Normalized to 1 kHz

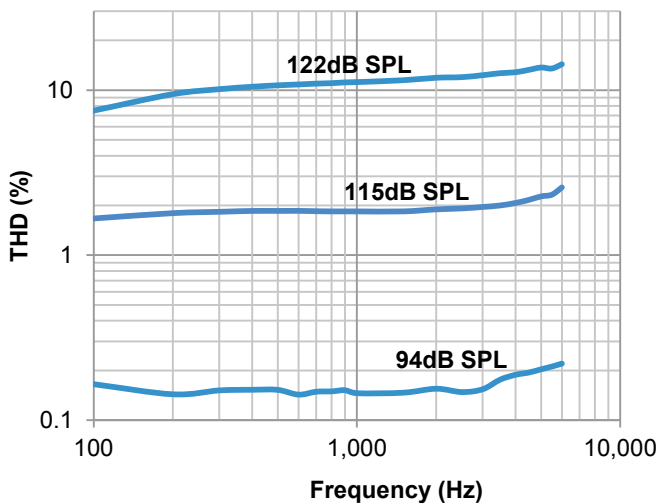

Figure 7: Typical THD vs Frequency

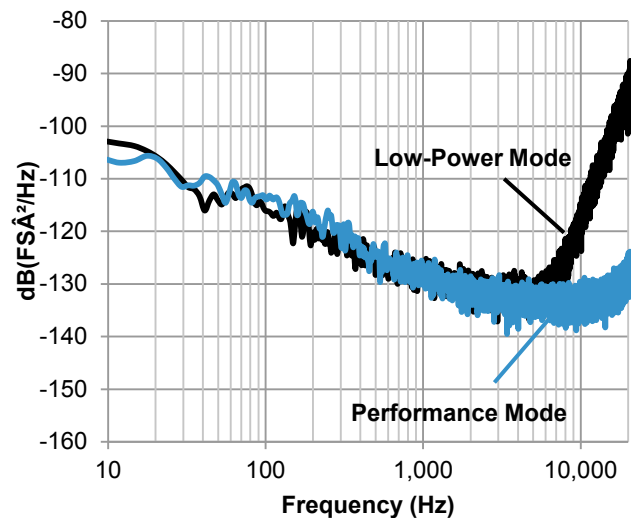
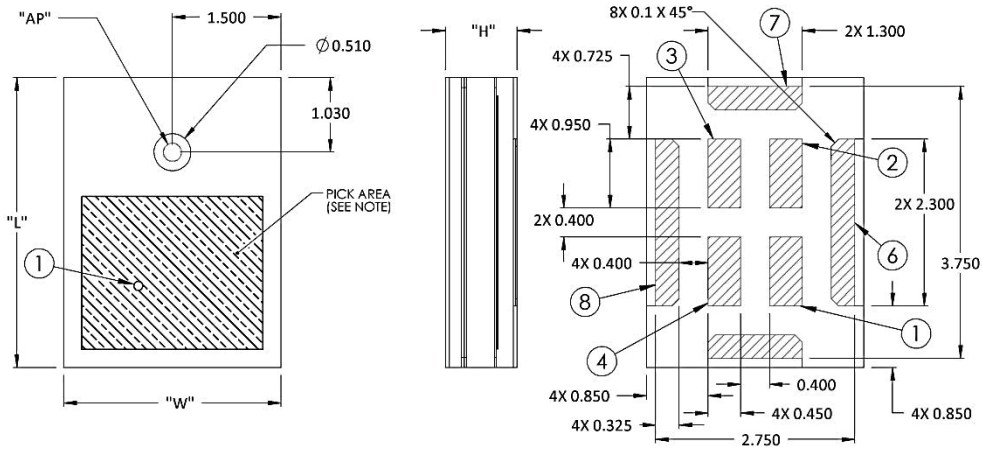

Figure 10: Typical Microphone Noise Floor

## Mechanical Specifications



tem	Dimension	Tolerance
Length (L)	4.00	±0.10
Width (W)	3.00	±0.10
Height (H)	1.00	±0.10
Acoustic Port (AP)	Ø0.25	±0.05

Pin #	Pin Name	Type	Description
1	DATA	Digital O	PDM Output
2	CLOCK	Digital I	Clock Input
3	SELECT	Non-Digital Input	Lo/Hi (L/R) Select. This pin is internally pulled low
4	Vdd	Power	Power Supply
5	GROUND	Power	Ground
6	GROUND	Power	Ground
7	GROUND	Power	Ground
8	GROUND	Power	Ground

### Example Land Pattern

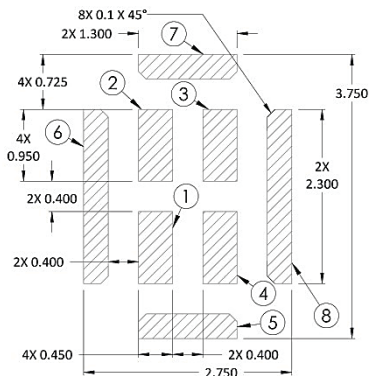

### Example Solder Stencil Pattern

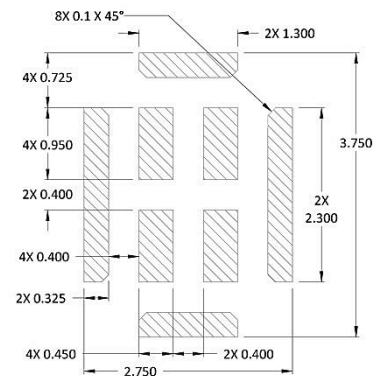

Notes: Pick Area only extends to 0.25 mm of any edge or hole unless otherwise specified.

Dimensions are in millimeters unless otherwise specified.

Tolerance is ±0.15mm unless otherwise specified

In the acoustic path, the recommended Gasket Cavity Diameter is  $D \geq 1.0\text{mm}$  and the recommended Case Hole Diameter is  $1.0 \leq D \leq 1.5\text{mm}$ . More information on AP size considerations can be found in the latest *SiSonic™ Design Guide* application note.

Further optimizations based on application should be performed.

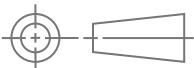

## Packaging & Marking Detail

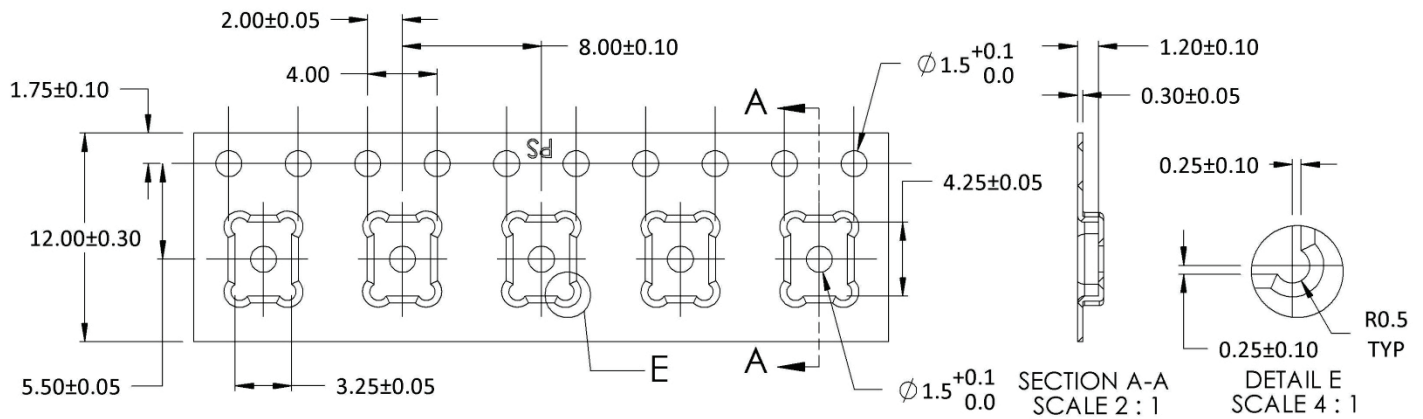

Model Number	Suffix	Reel Diameter	Quantity Per Reel
SPK0641HT4H-1	-7	13"	5,700

Component	Surface Resistance (ohms)
Reel	10 <sup>5</sup> - 10 <sup>9</sup>
Carrier Tape	10 <sup>5</sup> - 10 <sup>9</sup>
Cover Tape	10 <sup>4</sup> - 10 <sup>10</sup>

YWW: Year/Week date code  
 Letter: "o", orientation mark (pin 1)  
 Letter: "K"

Alpha Character A:

"S": Manufactured in China  
 "M": Manufactured in Malaysia  
 "I": Manufactured in Itasca

Version Number Vx:

Ex: Engineering version number x  
 Px: Prototype version number x  
 Mx: Mass production version number x

12345678:

Unique Job Identification Number for product traceability

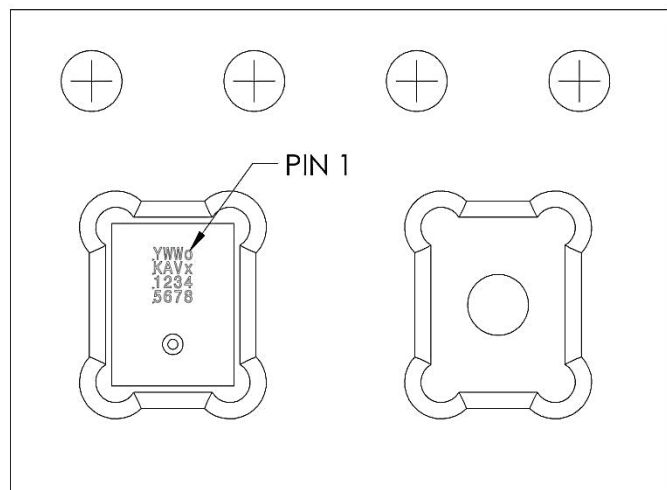

Notes: Dimensions are in millimeters unless otherwise specified.  
 Vacuum pickup only in the pick area indicated in Mechanical Specifications.  
 Tape & reel per EIA-481 Rev C.

Labels applied directly to reel and external package.

Shelf life: Twelve (12) months when devices are to be stored in factory supplied, unopened ESD moisture sensitive bag under maximum environmental conditions of 30°C, 70% R.H.

## Recommended Reflow Profile

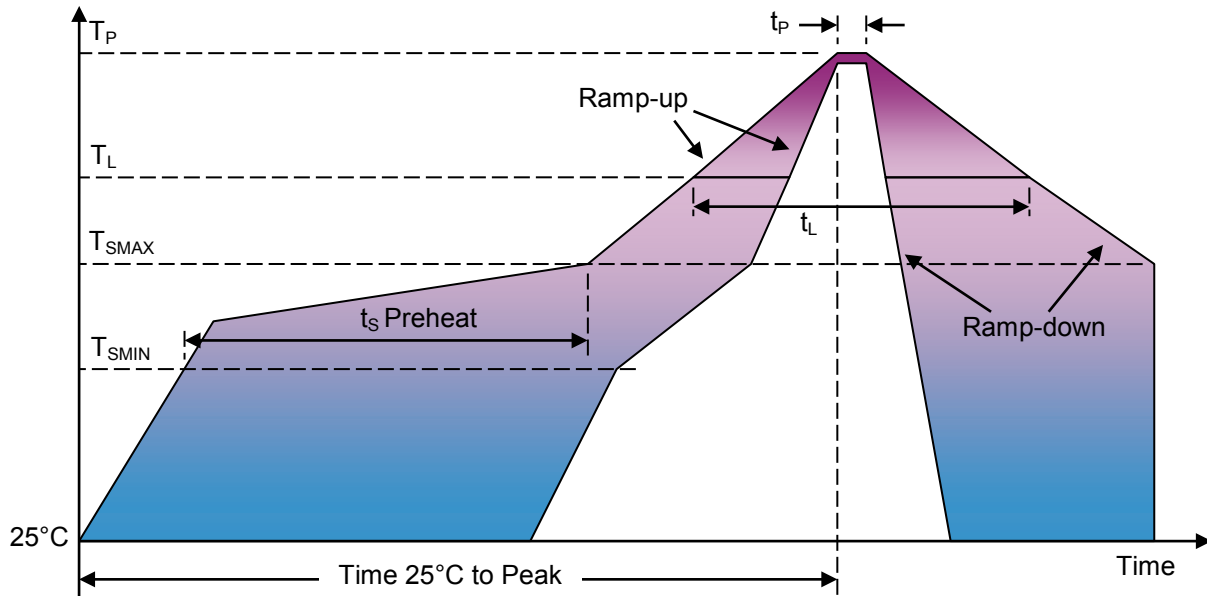

Profile Feature	Pb-Free
Average Ramp-up rate ( $T_{SMAX}$ to $T_P$ )	3°C/second max.
Preheat <ul style="list-style-type: none"> <li>• Temperature Min (<math>T_{SMIN}</math>)</li> <li>• Temperature Max (<math>T_{SMAX}</math>)</li> <li>• Time (<math>T_{SMIN}</math> to <math>T_{SMAX}</math>) (<math>t_s</math>)</li> </ul>	150°C 200°C 60-180 seconds
Time maintained above: <ul style="list-style-type: none"> <li>• Temperature (<math>T_L</math>)</li> <li>• Time (<math>t_L</math>)</li> </ul>	217°C 60-150 seconds
Peak Temperature ( $T_P$ )	260°C
Time within 5°C of actual Peak Temperature ( $t_p$ )	20-40 seconds
Ramp-down rate ( $T_P$ to $T_{SMAX}$ )	6°C/second max
Time 25°C to Peak Temperature	8 minutes max

Notes: Based on IPC/JDEC J-STD-020 Revision C.  
All temperatures refer to topside of the package, measured on the package body surface

### Additional Notes

- (A) MSL (moisture sensitivity level) Class 1.
- (B) Maximum of 3 reflow cycles is recommended.
- (C) In order to minimize device damage:
  - Do not board wash or clean after the reflow process.
  - Do not brush board with or without solvents after the reflow process.
  - Do not directly expose to ultrasonic processing, welding, or cleaning.
  - Do not insert any object in port hole of device at any time.
  - Do not apply over 30 psi of air pressure into the port hole.
  - Do not pull a vacuum over port hole of the microphone.
  - Do not apply a vacuum when repacking into sealed bags at a rate faster than 0.5 atm/sec.

## Materials Statement

Meets the requirements of the European RoHS directive 2011/65/EC as amended.

Meets the requirements of the industry standard IEC 61249-2-21:2003 for halogenated substances and Knowles Green Materials Standards Policy section on Halogen-Free.

Product is Beryllium Free according to limits specified on the Knowles Hazardous Material List (HSL for Products).

Ozone depleting substances are not used in the product or the processes used to make the product, including compounds listed in Annex A, B, and C of the "Montreal Protocol on Substances That Deplete the Ozone Layer."

## Reliability Specifications

Test	Description
Thermal Shock	100 cycles of air-air thermal shock from -40°C to +125°C with 15 minute soaks (IEC 68-2-4)
High Temperature Storage	+105°C environment for 1,000 hours (IEC 68-2-2 Test Ba)
Low Temperature Storage	-40°C environment for 1,000 hours (IEC 68-2-2 Test Aa)
High Temperature Bias	+105°C environment while under bias for 1,000 hours (IEC 68-2-2 Test Ba)
Low Temperature Bias	-40°C environment while under bias for 1,000 hours (IEC 68-2-2 Test Aa)
Temperature/Humidity Bias	+85°C/85% R.H. environment while under bias for 1,000 hours (JESD22-A101A-B)
Vibration	12 minutes in each axis from 20 to 2,000 Hz in X,Y, and Z directions with peak acceleration of 20g (MIL 883E, Method 2007.2,A)
ESD-LID/GND	3 discharges of ±8 kV direct contact to lid while unit is grounded. (IEC 61000-4-2)
ESD-MM	3 discharges of ±200V direct contact to I/O pins. (ESD STM5.2)
Reflow	5 reflow cycles with peak temperature of +260°C
Tumble test	200 tumbles in 100g block from a height of 1m onto a steel base
Mechanical Shock	3 pulses of 10,000g in each of the ±X, ±Y, ±Z directions while under bias (IEC 68-2-27 Test Ea)

Notes: After 3 reflow cycles, the sensitivity of the microphones shall not deviate more than 1dB from their initial value.



## Looking for pricing, stock, or lifecycle information?

Click below to explore more details on WIN SOURCE:

 [View SPK0641HT4H-1 on WIN SOURCE](#)

 [Knowles](#) Information

## Optimize Your Supply Chain with WIN SOURCE Solutions

-  Global Sourcing Solution
-  Obsolete Management
-  Cost Control Management
-  Shortage Management
-  Alternative Solution
-  Excess Inventory Management