



THE DATASHEET OF CH22LS



Global Modular Fuse Holders

CH Series



Insert Class CC fuse with the rejection feature facing the top.

CH Series

The CH Series of modular fuse holders is designed to accommodate a multitude of fuses from around the world, including North American Class-CC, Midget, Class gR, aR HSF, PV Series, and IEC Industrial Cylindrical (Class gG and aM) in four physical sizes: 8x32, 10x38, 14x51 and 22x58mm.

Products are manufactured in accordance with IEC 60269-1 or IEC 60269-2. cURus and cULus compliance as indicated in the part number tables.

Key features and benefits include:

- Multiple-pole configurations
- Finger-safe protection
- Lockout/tagout feature for added safety
- Optional "open fuse" indication
- 14x51 & 22x58 configurations are available with optional microswitches for remote "open fuse" indication, pre-breaking and fuse presence.
- Self-extinguishable UL 94V0 rated polyester material
- Multi-phase connections available for ganging poles
- Accepts wire security tags

Modular Fuse Holder Selection Table (10 x 38 and CC)

Part Numbers

| Series Size | Catalog Numbers | | Max Voltage & Current | UL | IEC | Phase Configuration | No. of 17.5mm Modules* | Box Qty. | Terminal Rating | SCCR Rating | Cooper Bussmann Fuses |
|--------------------|-----------------|---------------|--|-----|-----|---------------------|------------------------|----------|------------------|---|--|
| | W/O Indication | W/Indication | | | | | | | | | |
| CHCC Class CC | CHCC1D | CHCC1DI** | UL | †† | | 1-pole | 1 | 12 | 75° Cu Wire Only | 200kA | LP-CC, FNQ-R, KTK-R |
| | CHCC2D | CHCC2DI** | 600Vac/dc, 30A | †† | | 2-pole | 2 | 6 | | | |
| | CHCC3D | CHCC3DI** | | †† | | 3-pole | 3 | 4 | | | |
| | — | CHCC1DI-48*** | UL 48Vdc, 30A | †† | | 1-pole | 1 | 12 | | | |
| CHPV | CHPV1 | CHPV1I** | UL 1000Vdc, 30A IEC 1000Vdc, 32A (3.5 Watt) | ††† | • | 1-pole | 1 | 12 | 75° Cu Wire Only | 33kA | PV Series |
| CHM 10x38 & Midget | CHM1D | CHM1DI** | UL | † | • | 1-pole | 1 | 12 | 75° Cu Wire Only | Rating varies depending on fuse used in holder. | FNQ, KLM, FNM, KTK, BAF, FWA, DCM, C10 Series, AGU, BAN, FWC |
| | CHM1DNX | - | 600Vac/dc, 30A | | • | 1 Neutral Pole | 1 | 12 | | | |
| | CHM1DN | CHM1DNI** | | | • | 1-pole + Neutral | 2 | 6 | | | |
| | CHM2D | CHM2DI** | IEC 690Vac, 32A | † | • | 2-pole | 2 | 6 | | | |
| | CHM3D | CHM3DI** | (3 Watt) | † | • | 3-pole | 3 | 4 | | | |
| | CHM3DN | CHM3DNI** | | | • | 3-pole + Neutral | 4 | 3 | | | |
| | CHM4D | CHM4DI** | | | • | 4-pole | 4 | 3 | | | |
| | — | CHM1DI-48*** | UL 48Vdc, 30A IEC 48Vdc, 32A (3 Watt) | † | • | 1-pole | 1 | 12 | | | |

MFH Wire Range and Torque - CH Series: CHCC, CHM & CHPV

| Wire Range | Conductor Type 75°C Cu Wire Only | Conductors | Torque |
|--|-------------------------------------|------------|-----------------------|
| 18-12 AWG (0.8 - 4.0mm ²) | Solid/Stranded | Single | 20 lb-in 2.3 N•m |
| 10 AWG (5.0mm ²) | Solid | Single | 25 lb-in (2.8 N•m) |
| 10-8 AWG (5.0 - 8.0mm ²) | Stranded | | |
| 18-14 AWG (0.8 - 2.5mm ²) | Solid | Dual | |
| 18-10 AWG (0.8 - 5.0mm ²) | Stranded | | |

† UL Recognized (cURus)

†† UL Listed (cULus)

††† UL Recognized, Standard 4248-1

*Holder width as compared to standard 17.5mm module, i.e., 1 = 17.5mm 2 = 35mm.

**90V minimum required for illumination

***12V minimum required for illumination

Modular Fuseholder Selection Table (8x32, 14x51, and 22x58)

Part Numbers

| Series/ Size | Catalog Numbers | | Max Voltage & Current | IEC | UL | Phase Configuration | No. of 17.5mm Modules* | Box Qty. | Wire Range | Maximum Torque | | | |
|-----------------|-----------------|--------------|--|-----|----|--------------------------------|------------------------------|-------------|----------------------------------|-------------------|---|--------------------------------|-------------------|
| | W/O Indication | W/Indication | | | | | | | | | | | |
| CH08 8X32 | CH081D | CH081DI | IEC 400Vac 25A | • | | 1-pole | 1 | 12 | 1-16mm ² (18-6 AWG) | 2.5 N•m (22in-lb) | | | |
| | CH081DNX | - | | | | 1 Neutral Pole | 1 | 12 | | | | | |
| | CH081DNS | CH081DNSI | | | | 1-pole + Neutral | 1 | 12 | | | | | |
| | CH081DN | CH081DNI | | | | IEC 400Vac 25A | • | | 1-pole + Neutral | 2 | 6 | 1-16mm ² (18-6 AWG) | 2.5 N•m (22in-lb) |
| | CH082D | CH082DI | | | | | | | 2-pole | 2 | 6 | | |
| | CH083D | CH083DI | | | | | | | 3-pole | 3 | 4 | | |
| | CH083DNS | CH083DNSI | | | | | | | 3-pole + Neutral | 3 | 4 | | |
| | CH083DN | CH083DNI | | | | | | | 3-pole + Neutral | 4 | 3 | | |
| | CH084D | CH084DI | | | | | | | 4-pole | 4 | 3 | | |
| CH14 14X51 | CH141D | CH141DICH1 | UL/cURus 600Vac/dc, 40A (5 Watt) IEC 690Vac, 50A | • | † | 1-pole | 1.5 | 6 | 2.5-16mm ² (14-6 AWG) | 3.0 N•m (26in-lb) | | | |
| | CH141DMS | -14X51 | | | | 1-pole + Microswitch | 1.5 | 6 | | | | | |
| | CH141DNX | - | | | | 1 Neutral Pole | 1.5 | 6 | | | | | |
| | CH141DN | CH141DNI | | | | 1-pole + Neutral | 3 | 3 | | | | | |
| | CH142D | CH142DI | | | | 2-pole | 3 | 3 | | | | | |
| | CH143D | CH143DI | | | | 3-pole | 4.5 | 2 | | | | | |
| | CH143DMS | - | | | | 3-pole + Microswitch | 4.5 | 2 | | | | | |
| | CH143DN | CH143DNI | | | | 3-pole + Neutral | 6 | 1 | | | | | |
| | CH143DNMS | - | | | | 3-pole + Neutral + Microswitch | 6 | 1 | | | | | |
| CH144D | CH144DI | 4-pole | 6 | 1 | | | | | | | | | |
| CH22 22X58 | CH221B | Not | UL/cURus 600Vac/dc, 100A (9.5 Watt) IEC 690Vac, 125A | • | † | 1-pole | 2 | 6 | 2.5-50mm ² (14-1 AWG) | 4.0 N•m (35in-lb) | | | |
| | CH221BMS | Available | | | | 1-pole + Microswitch | 2 | 6 | | | | | |
| | CH221BNX | with | | | | 1 Neutral Pole | 2 | 6 | | | | | |
| | CH221BN | local | | | | 1-pole + Neutral | 4 | 3 | | | | | |
| | CH222B | neon | | | | 2-pole | 4 | 3 | | | | | |
| | CH223B | indication | | | | 3-pole | 6 | 2 | | | | | |
| | CH223BMS | (remote | | | | 3-pole + Microswitch | 6 | 2 | | | | | |
| | CH223BN | microswitch | | | | 3-pole + Neutral | 8 | 1 | | | | | |
| | CH223BNMS | only) | | | | 3-pole + Neutral + Microswitch | 8 | 1 | | | | | |
| CH224B | | 4-pole | 8 | 1 | | | | | | | | | |

† UL Recognized (cURus)

†† UL Listed (cULus)

*Holder width as compared to standard, i.e., 1 = 17.5mm module 2 = 35mm.

**90V minimum required for illumination

Recommended Cooper Bussmann™ Fuses:

8x32 IEC Cylindrical - C08 Series

10x38 North American Class CC Fuses - LP-CC, FNQ-R, KTK-R

Fuses - FNQ, KTK, AGU, KLM, BAF, FNM, FWA, FWC, C10 Series, PV Series

14x51 Fuses - FWX, FWH, FWP & NON, C14 Series

22x58 Fuses - FWP, C22 Series

Manual Multi-phase Construction (8x32, 10x38, 14x51mm)

Additional poles can be added by using the accessories shown on page 2 of this data sheet. The following components are required for each additional pole, up to a maximum of 4-poles.

Part Number Description

JV-L Multi-pole Connector Kit (10x38)

CH810-HP 8x32 Handle Pin

CH14-HP 14x51mm Handle Pin

AL-D Multi-pole Connector Kit (8x32)

Contact Cooper Bussmann Application Engineering for more information.

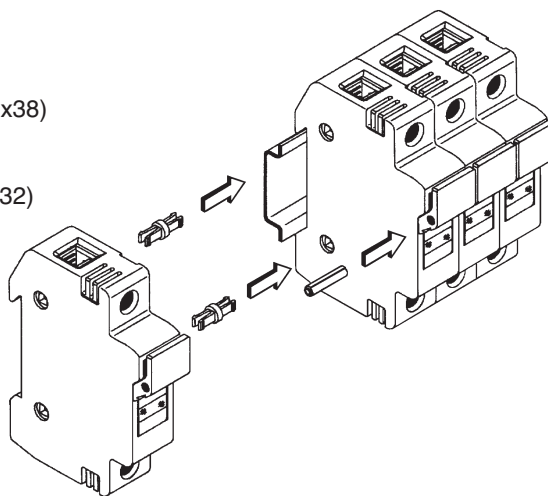

Accessories for use with the new CH Series of Modular Fuseholders
 (For diagram of multi-phase construction, see page 2)

| Accessory | For Use with Fuse Holders | Part Number | No. of Poles | Box Quantity |
|-------------------------------------|---|-------------------------|--------------|--------------|
| Multi-Phase Connection Links | CH08 and CH14 Series | AL-D | – | 12 |
| Multi-Phase Connection Kit* | CHM and CHCC Series | JV-L | – | – |
| Multi-Phase Handle Pins | CH08 Series CH14 Series | CH810-HP CH14-HP | – – | 12 |
| Neutral Links | CH08 Series CH14 Series CH22 Series | C08NL C14NL C22NL | – – – | 10 |
| Operated-Fuse Micro-Switches | CH141 Series CH143 Series | CH14MS-1D CH14MS-3D | 1 3 | 5 2 |
| PLC Module (see page 6 for details) | CHM and CHCC Series | CH-PLC† | 1 | 1 |
| IP20 Kit | CH22 Series | CH22IP20 | – | 12 |
| Lock Support | CH22 Series | CH22LS | – | 5 |

*Kit contains 3-Spring pins and 6-connection links
 †UL Listed (cULus)



Multi-Phase
Connection Links



Neutral Links



Multi-Phase
Handle Pins

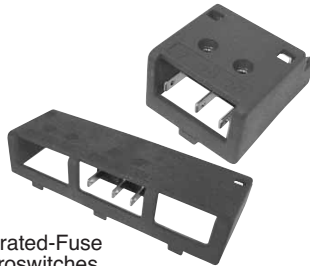

Operated-Fuse
Microswitches



Programmable Logic
Controller
(PLC)



Lock Support



IP20 Kit

Dimensions - mm (in)

8x32mm

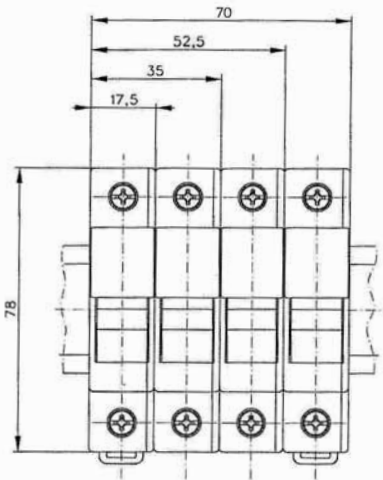
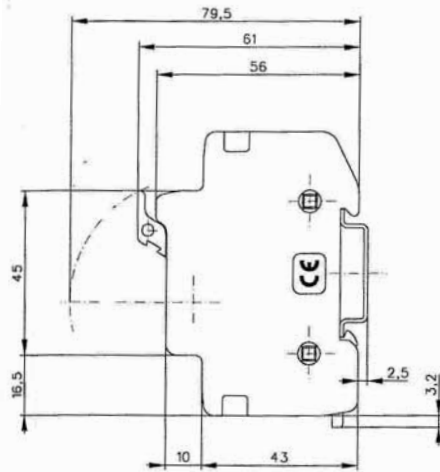

10x38mm

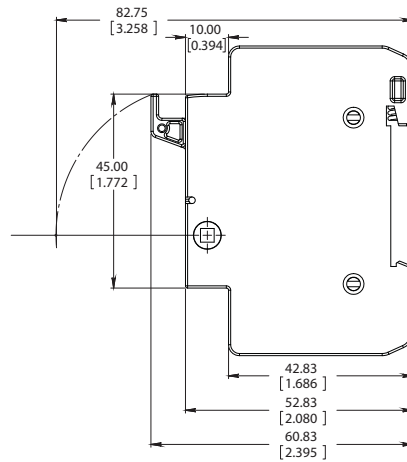
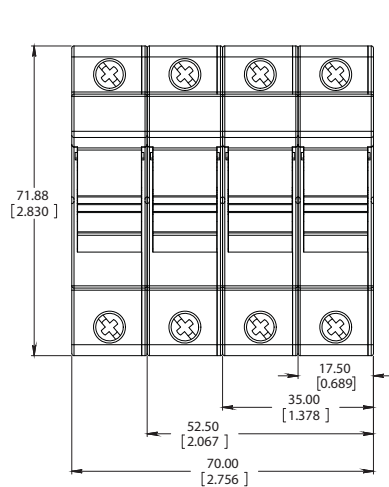

14x51mm

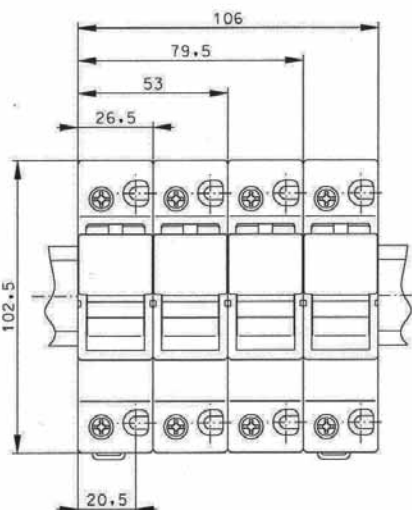
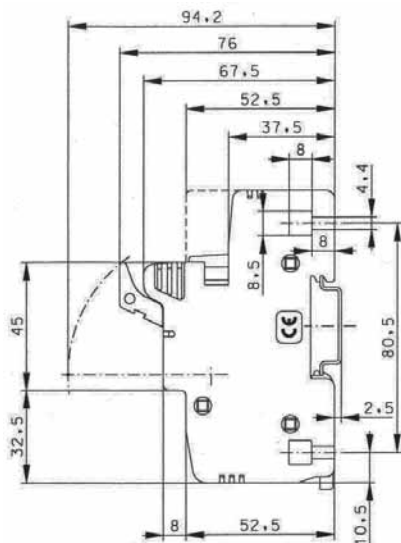

Dimensions - mm (in)

22x58mm

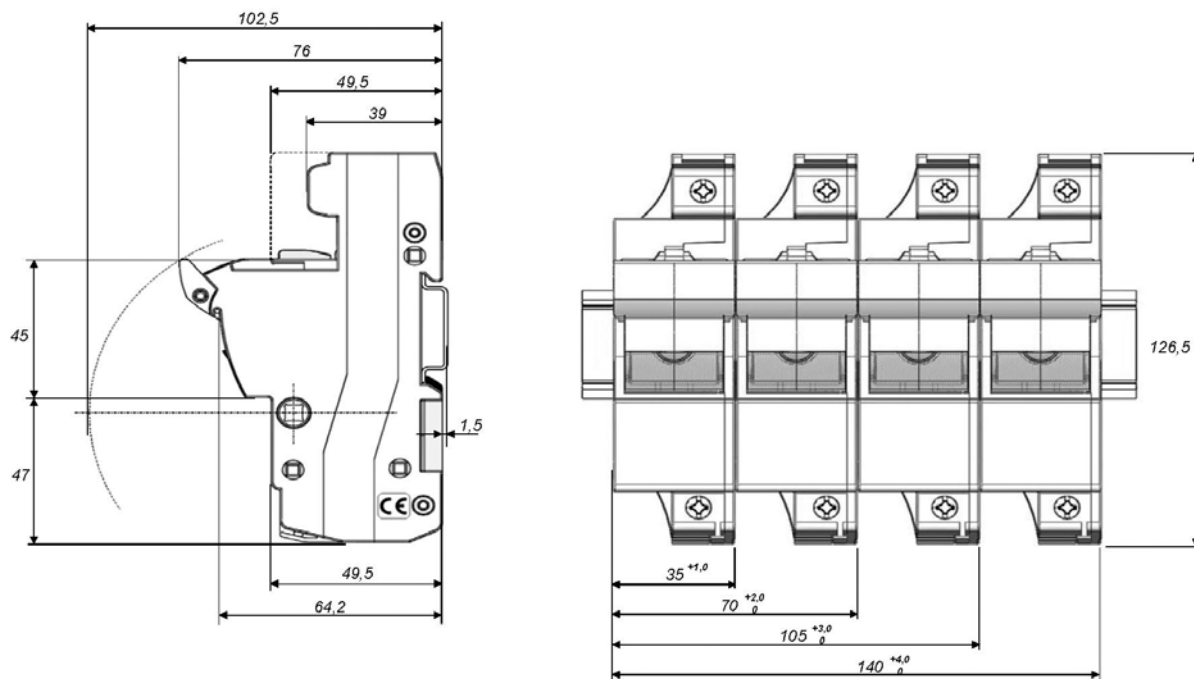

Using High Speed Fuses (Semiconductor Protection)

The CH Series of modular fuse holders may be used in conjunction with Class gR and aR high speed fuses. The continuous load current should not exceed that shown in the tables below for specific high speed fuse types/amp ratings so that the watts loss of the fuse does not exceed the watts loss capability of the holder. High speed fuses may also need to be derated based on specific application and ambient temperature.

CHM Series (10x38)

| High Speed Fuse | Maximum Continuous Amps | High Speed Fuse | Maximum Continuous Amps |
|-----------------|-------------------------|-----------------|-------------------------|
| FWA-5A10F | 5 | FWC-6A10F | 6 |
| FWA-10A10F | 10 | FWC-8A10F | 8 |
| FWA-15A10F | 14 | FWC-10A10F | 10 |
| FWA-20A10F | 18 | FWC-12A10F | 12 |
| FWA-25A10F | 20 | FWC-16A10F | 15 |
| FWA-30A10F | 24 | FWC-20A10F | 16 |
| - | - | FWC-25A10F | 19 |
| - | - | FWC-32A10F | 21 |

CH22 Series (22x58)

| High Speed Fuse | Maximum Continuous Amps |
|-----------------|-------------------------|
| FWP-20A22F | 20 |
| FWP-25A22F | 25 |
| FWP-32A22F | 32 |
| FWP-40A22F | 40 |
| FWP-50A22F | 50 |
| FWP-63A22F | 58 |
| FWP-80A22F | 66 |
| FWP-100A22F | 78 |

CH14 Series (14x51)

| High Speed Fuse | Maximum Continuous Amps | High Speed Fuse | Maximum Continuous Amps | High Speed Fuse | Maximum Continuous Amps | High Speed Fuse | Maximum Continuous Amps |
|-----------------|-------------------------|-----------------|-------------------------|-----------------|-------------------------|-----------------|-------------------------|
| FWX-5A14F | 5 | FWH-5A14F | 5 | FWP-5A14F | 5 | FWP-32A14F | 27 |
| FWX-10A14F | 10 | FWH-10A14F | 10 | FWP-10A14F | 10 | FWP-40A14F | 32 |
| FWX-15A14F | 15 | FWH-15A14F | 14 | FWP-15A14F | 14 | FWP-50A14F | 38 |
| FWX-20A14F | 20 | FWH-20A14F | 18 | FWP-20A14F | 18 | - | - |
| FWX-25A14F | 24 | FWH-25A14F | 21 | FWP-25A14F | 21 | - | - |
| FWX-30A14F | 27 | FWH-30A14F | 22 | FWP-30A14F | 22 | - | - |

Please contact Cooper Bussmann Application Engineering for more information regarding high speed fuse application.

Remote Fuse Monitoring Accessory – CH-PLC

UL Class CC, Midget and IEC 10x38 fuses

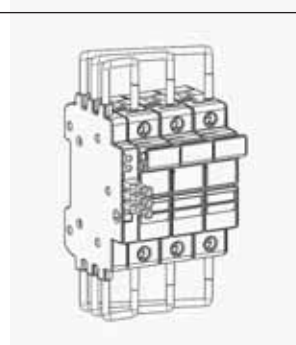

Description

A resettable three-phase remote fuse monitor that integrates with a Programmable Logic Controller (PLC) or other monitoring and control equipment.

Specifications:

- **Power Input:** 24Vdc / 5mA
- **Sensing Voltage:** 600V/30mA
- **Output Signals:** Digital 0Vdc (Low), 24Vdc (High)
 - 0Vdc Low – Fuse is good
 - 24Vdc High – Fuse has opened

When the fuse opens, the output signal is sent high and will remain high until the unit is reset

- **Rated Impulse Voltage:** 8kV
- **Local Indication:** Two distinct LEDs indicate unit power (green) and open fuse (red). Upon the replacement of the fuse, the actuation of the reset switch will reset the open fuse LED
- **Flammability Rating:** UL 94V0

Wiring:

- For power, signal and ground connections use 22-24AWG (0.25mm²) 300V rated wire

Emissions and Immunity Testing:

- Electrostatic Discharge IEC 61000-4-2
- Electrical Fast Transient/Burst IEC 6100-4-4
- Surge Immunity IEC61000-4-5

Packaging:

- The CH-PLC is packaged individually
- A single unit monitors up to three phases
- Package includes 0.11" (2.8mm) quick connects for power, signal and ground connections

De-energize all circuits before installing or removing any CH-PLC devices and follow all prescribed safety procedures.

The only controlled copy of this Data Sheet is the electronic read-only version located on the Cooper Bussmann Network Drive. All other copies of this document are by definition uncontrolled. This bulletin is intended to clearly present comprehensive product data and provide technical information that will help the end user with design applications. Cooper Bussmann reserves the right, without notice, to change design or construction of any products and to discontinue or limit distribution of any products. Cooper Bussmann also reserves the right to change or update, without notice, any technical information contained in this bulletin. Once a product has been selected, it should be tested by the user in all possible applications.

Minimum Circuit Voltage:

- Minimum circuit voltage required across the CH holder is 100Vac for the remote indication device to operate

Installation Technique:

- Mounts on the left side of the fuse holder and mechanically interlocks with the fuse holder switch handle with hardware provided

IP20 Rating: Yes

Environmental Data:

- Storage and Operating Temperature: -20°C to 75°C

Agency Information:

- UL 508
- cULus to CSA Standard 22.2 No.14

PLC Programming:

- The CH-PLC signal line is designed to provide a digital input to a PLC I/O card.
- Programmable Logic Control program must be written to properly interpret the input signal to the PLC.
- The PLC program should check for consecutive high signals before taking action on a critical process.

Looking for pricing, stock, or lifecycle information?

Click below to explore more details on WIN SOURCE:

 [View CH22LS on WIN SOURCE](#)

 [Eaton Bussmann Information](#)

Optimize Your Supply Chain with WIN SOURCE Solutions

-  Global Sourcing Solution
-  Obsolete Management
-  Cost Control Management
-  Shortage Management
-  Alternative Solution
-  Excess Inventory Management