



**THE DATASHEET OF
LTC2912HDDDB-1#TRMPBF**



Single UV/OV Voltage Monitor

FEATURES

- **Monitors Single Voltage**
- **Adjustable UV and OV Trip Values**
- **Guaranteed Threshold Accuracy: $\pm 1.5\%$**
- **Power Supply Glitch Immunity**
- Adjustable Reset Timeout with Timeout Disable
- 29 μ A Quiescent Current
- Open-Drain \overline{OV} and \overline{UV} Outputs
- Guaranteed \overline{OV} and \overline{UV} for $V_{CC} \geq 1V$
- Available in 8-Lead ThinSOT™ and (3mm \times 2mm) DFN Packages

APPLICATIONS

- Desktop and Notebook Computers
- Network Servers
- Core, I/O Voltage Monitors

DESCRIPTION

The LTC[®]2912 voltage monitor is designed to detect power supply undervoltage and overvoltage events. The VL and VH monitor inputs include filtering to reject brief glitches, thereby ensuring reliable reset operation without false or noisy triggering. An adjustable timer defines the duration of the overvoltage and undervoltage reset outputs which function independently. While the LTC2912 operates directly from 2.3V to 6V supplies, an internal V_{CC} shunt regulator coupled with low supply current demand allows operation from higher voltages such as 12V, 24V or 48V.

Three output configurations are available: the LTC2912-1 has a latch control for the \overline{OV} output; the LTC2912-2 has an \overline{OV} and \overline{UV} output disable feature for margining applications; the LTC2912-3 is identical to the LTC2912-1 but with a noninverting, \overline{OV} output.

The LTC2912 provides a precise, versatile, space-conscious micropower solution for voltage monitoring.

All registered trademarks and trademarks are the property of their respective owners.

TYPICAL APPLICATION

Single OV/UV Supply Monitor, 3.3V $\pm 10\%$ Tolerance

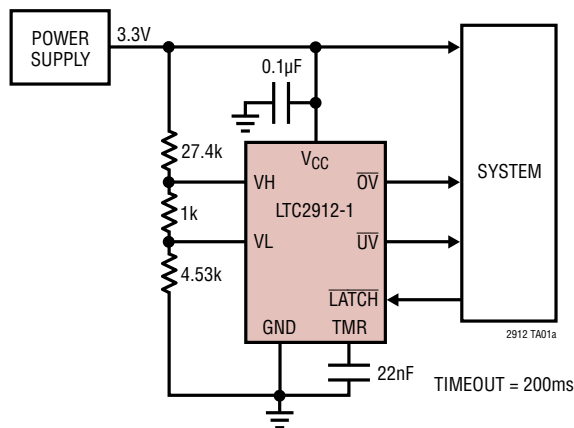

Reset Time-Out Period vs Capacitance

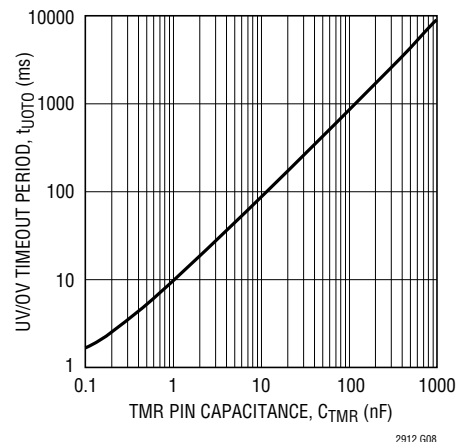

LTC2912

ABSOLUTE MAXIMUM RATINGS (Note 1)

Terminal Voltages

V_{CC} (Note 3)	-0.3V to 6V
\overline{OV} , \overline{UV} , \overline{OV}	-0.3V to 16V
TMR	-0.3V to ($V_{CC} + 0.3V$)
V_H , V_L , \overline{LATCH} , DIS	-0.3V to 7.5V

Terminal Currents

I_{VCC}	10mA
$I_{\overline{UV}}$, $I_{\overline{OV}}$, $I_{\overline{OV}}$	10mA

Operating Temperature Range

LTC2912C	0°C to 70°C
LTC2912I	-40°C to 85°C
LTC2912H	-40°C to 125°C
Storage Temperature Range	-65°C to 150°C
Lead Temperature (Soldering, 10 sec)	
TSOT	300°C

PACKAGE/ORDER INFORMATION

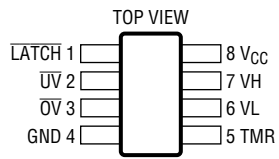
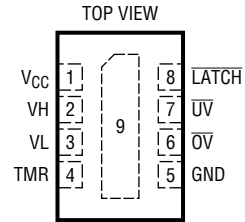
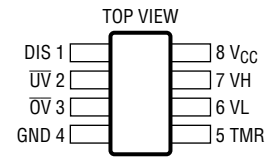
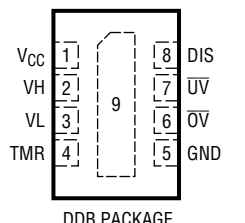
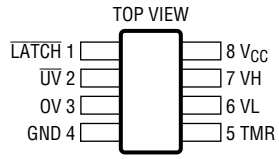
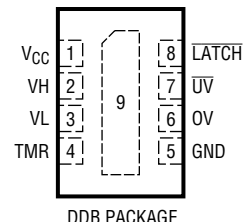
<p>LTC2912-1</p>  <p>TOP VIEW</p> <p>TS8 PACKAGE 8-LEAD PLASTIC TSOT-23 $T_{JMAX} = 125^{\circ}C$, $\theta_{JA} = 195^{\circ}C/W$</p>	<p>LTC2912-1</p>  <p>TOP VIEW</p> <p>DDB PACKAGE 8-LEAD (3mm x 2mm) PLASTIC DFN $T_{JMAX} = 125^{\circ}C$, $\theta_{JA} = 55^{\circ}C/W$ EXPOSED PAD (PIN 9) IS GND, MUST BE SOLDERED TO PCB</p>
<p>LTC2912-2</p>  <p>TOP VIEW</p> <p>TS8 PACKAGE 8-LEAD PLASTIC TSOT-23 $T_{JMAX} = 125^{\circ}C$, $\theta_{JA} = 195^{\circ}C/W$</p>	<p>LTC2912-2</p>  <p>TOP VIEW</p> <p>DDB PACKAGE 8-LEAD (3mm x 2mm) PLASTIC DFN $T_{JMAX} = 125^{\circ}C$, $\theta_{JA} = 55^{\circ}C/W$ EXPOSED PAD (PIN 9) IS GND, MUST BE SOLDERED TO PCB</p>
<p>LTC2912-3</p>  <p>TOP VIEW</p> <p>TS8 PACKAGE 8-LEAD PLASTIC TSOT-23 $T_{JMAX} = 125^{\circ}C$, $\theta_{JA} = 195^{\circ}C/W$</p>	<p>LTC2912-3</p>  <p>TOP VIEW</p> <p>DDB PACKAGE 8-LEAD (3mm x 2mm) PLASTIC DFN $T_{JMAX} = 125^{\circ}C$, $\theta_{JA} = 55^{\circ}C/W$ EXPOSED PAD (PIN 9) IS GND, MUST BE SOLDERED TO PCB</p>

ORDER INFORMATION

Lead Free Finish

TAPE AND REEL (MINI)	TAPE AND REEL	PART MARKING*	PACKAGE DESCRIPTION	TEMPERATURE RANGE
LTC2912CTS8-1#TRMPBF	LTC2912CTS8-1#TRPBF	LTCJW	8-Lead Plastic TSOT-23	0°C to 70°C
LTC2912ITS8-1#TRMPBF	LTC2912ITS8-1#TRPBF	LTCJW	8-Lead Plastic TSOT-23	-40°C to 85°C
LTC2912HTS8-1#TRMPBF	LTC2912HTS8-1#TRPBF	LTCJW	8-Lead Plastic TSOT-23	-40°C to 125°C
LTC2912CDDB-1#TRMPBF	LTC2912CDDB-1#TRPBF	LCJZ	8-Lead (3mm × 2mm) Plastic DFN	0°C to 70°C
LTC2912IDDB-1#TRMPBF	LTC2912IDDB-1#TRPBF	LCJZ	8-Lead (3mm × 2mm) Plastic DFN	-40°C to 85°C
LTC2912HDDB-1#TRMPBF	LTC2912HDDB-1#TRPBF	LCJZ	8-Lead (3mm × 2mm) Plastic DFN	-40°C to 125°C
LTC2912CTS8-2#TRMPBF	LTC2912CTS8-2#TRPBF	LTCJX	8-Lead Plastic TSOT-23	0°C to 70°C
LTC2912ITS8-2#TRMPBF	LTC2912ITS8-2#TRPBF	LTCJX	8-Lead Plastic TSOT-23	-40°C to 85°C
LTC2912HTS8-2#TRMPBF	LTC2912HTS8-2#TRPBF	LTCJX	8-Lead Plastic TSOT-23	-40°C to 125°C
LTC2912CDDB-2#TRMPBF	LTC2912CDDB-2#TRPBF	LCKB	8-Lead (3mm × 2mm) Plastic DFN	0°C to 70°C
LTC2912IDDB-2#TRMPBF	LTC2912IDDB-2#TRPBF	LCKB	8-Lead (3mm × 2mm) Plastic DFN	-40°C to 85°C
LTC2912HDDB-2#TRMPBF	LTC2912HDDB-2#TRPBF	LCKB	8-Lead (3mm × 2mm) Plastic DFN	-40°C to 125°C
LTC2912CTS8-3#TRMPBF	LTC2912CTS8-3#TRPBF	LTCJY	8-Lead Plastic TSOT-23	0°C to 70°C
LTC2912ITS8-3#TRMPBF	LTC2912ITS8-3#TRPBF	LTCJY	8-Lead Plastic TSOT-23	-40°C to 85°C
LTC2912HTS8-3#TRMPBF	LTC2912HTS8-3#TRPBF	LTCJY	8-Lead Plastic TSOT-23	-40°C to 125°C
LTC2912CDDB-3#TRMPBF	LTC2912CDDB-3#TRPBF	LCKC	8-Lead (3mm × 2mm) Plastic DFN	0°C to 70°C
LTC2912IDDB-3#TRMPBF	LTC2912IDDB-3#TRPBF	LCKC	8-Lead (3mm × 2mm) Plastic DFN	-40°C to 85°C
LTC2912HDDB-3#TRMPBF	LTC2912HDDB-3#TRPBF	LCKC	8-Lead (3mm × 2mm) Plastic DFN	-40°C to 125°C

Contact the factory for parts specified with wider operating temperature ranges. *The temperature grade is identified by a label on the shipping container.

[Tape and reel specifications](#). Some packages are available in 500 unit reels through designated sales channels with #TRMPBF suffix.

ELECTRICAL CHARACTERISTICS

The ● denotes the specifications which apply over the full operating temperature range, otherwise specifications are at $T_A = 25^\circ\text{C}$. $V_{CC} = 3.3\text{V}$, $V_L = 0.45\text{V}$, $V_H = 0.55\text{V}$, $\text{LATCH} = V_{CC}$ unless otherwise noted. (Note 2)

SYMBOL	PARAMETER	CONDITIONS	MIN	TYP	MAX	UNITS	
V_{SHUNT}	V_{CC} Shunt Regulator Voltage	$I_{CC} = 5\text{mA}$	● 6.2	6.6	7.2	V	
		$I_{CC} = 5\text{mA}$ (H-Grade)	● 6.2	6.6	7.3	V	
ΔV_{SHUNT}	V_{CC} Shunt Regulator Load Regulation	$I_{CC} = 2\text{mA}$ to 10mA	●	200	300	mV	
V_{CC}	Supply Voltage (Note 3)		● 2.3		V_{SHUNT}	V	
$V_{\text{CCR(MIN)}}$	Minimum V_{CC} Output Valid	$\text{DIS} = 0\text{V}$	●		1	V	
$V_{\text{CC(UVLO)}}$	Supply Undervoltage Lockout	$\text{DIS} = 0\text{V}$, V_{CC} Rising	● 1.9	2	2.1	V	
$\Delta V_{\text{CC(UVHYST)}}$	Supply Undervoltage Lockout Hysteresis	$\text{DIS} = 0\text{V}$	● 5	25	50	mV	
I_{CC}	Supply Current	$V_{CC} = 2.3\text{V}$ to 6V	●	29	70	μA	
V_{UOT}	Undervoltage/Overvoltage Threshold		● 492	500	508	mV	
t_{UOD}	Undervoltage/Overvoltage Threshold to Output Delay	$V_{\text{Hn}} = V_{\text{UOT}} - 5\text{mV}$ or $V_{\text{Ln}} = V_{\text{UOT}} + 5\text{mV}$	●	50	125	500	μs
I_{VHL}	V_H , V_L Input Current		●		± 15	nA	
		H-Grade	●		± 30	nA	
t_{UOTO}	UV/OV Time-Out Period	$C_{\text{TMR}} = 1\text{nF}$	● 6	8.5	12.5	ms	
		$C_{\text{TMR}} = 1\text{nF}$ (H-Grade)	● 6	8.5	14	ms	
$V_{\text{LATCH(VIH)}}$	OV Latch Clear Input High		● 1.2			V	
$V_{\text{LATCH(VIL)}}$	OV Latch Clear Input Low		●		0.8	V	
I_{LATCH}	LATCH Input Current	$V_{\text{LATCH}} > 0.5\text{V}$	●		± 1	μA	
I_{DIS}	DIS Input Current	$V_{\text{DIS}} > 0.5\text{V}$	●	1	2	μA	
$V_{\text{DIS(VIH)}}$	DIS Input High		● 1.2			V	
$V_{\text{DIS(VIL)}}$	DIS Input Low		●		0.8	V	
$I_{\text{TMR(UP)}}$	TMR Pull-Up Current	$V_{\text{TMR}} = 0\text{V}$	● -1.3	-2.1	-2.8	μA	
		$V_{\text{TMR}} = 0\text{V}$ (H-Grade)	● -1.2	-2.1	-2.8	μA	
$I_{\text{TMR(DOWN)}}$	TMR Pull-Down Current	$V_{\text{TMR}} = 1.6\text{V}$	● 1.3	2.1	2.8	μA	
		$V_{\text{TMR}} = 1.6\text{V}$ (H-Grade)	● 1.2	2.1	2.8	μA	
$V_{\text{TMR(DIS)}}$	Timer Disable Voltage	Referenced to V_{CC}	● -180	-270		mV	
V_{OH}	Output Voltage High $\overline{\text{UV/OV/OV}}$	$V_{CC} = 2.3\text{V}$, $I_{\overline{\text{UV/OV/OV}}} = -1\mu\text{A}$	● 1			V	
V_{OL}	Output Voltage Low $\overline{\text{UV/OV/OV}}$	$V_{CC} = 2.3\text{V}$, $I_{\overline{\text{UV/OV/OV}}} = 2.5\text{mA}$	●	0.10	0.30	V	
		$V_{CC} = 1\text{V}$, $I_{\overline{\text{UV}}} = 100\mu\text{A}$	●	0.01	0.15	V	

Note 1: Stresses beyond those listed under Absolute Maximum Ratings may cause permanent damage to the device. Exposure to any Absolute Maximum Rating condition for extended periods may affect device reliability and lifetime.

Note 2: All currents into pins are positive; all voltages are referenced to GND unless otherwise noted.

Note 3: V_{CC} maximum pin voltage is limited by input current. Since the V_{CC} pin has an internal 6.5V shunt regulator, a low impedance supply that exceeds 6V may exceed the rated terminal current. Operation from higher voltage supplies requires a series dropping resistor. See Applications Information.

TIMING DIAGRAMS

VH Monitor Timing

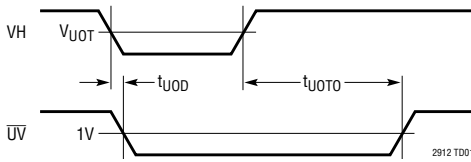

VL Monitor Timing

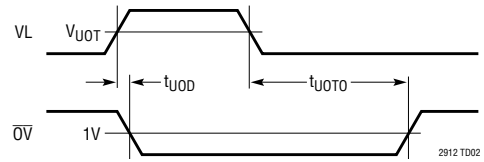

VH Monitor Timing (TMR Pin Strapped to V_{CC})

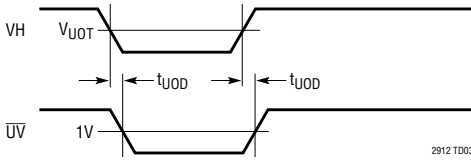

VL Monitor Timing (TMR Pin Strapped to V_{CC})

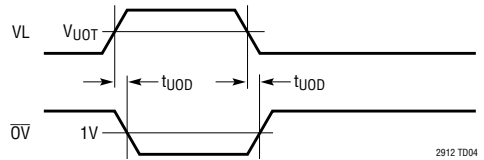

TYPICAL PERFORMANCE CHARACTERISTICS

Input Threshold Voltage vs Temperature

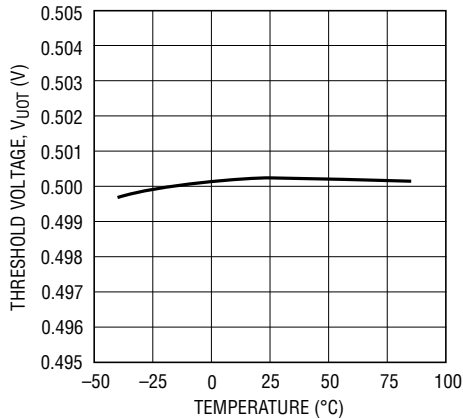

Supply Current vs Temperature

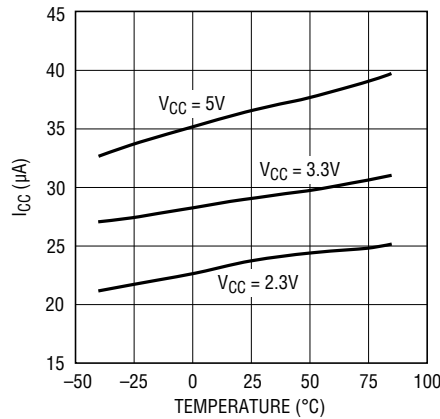

V_{CC} Shunt Voltage vs Temperature

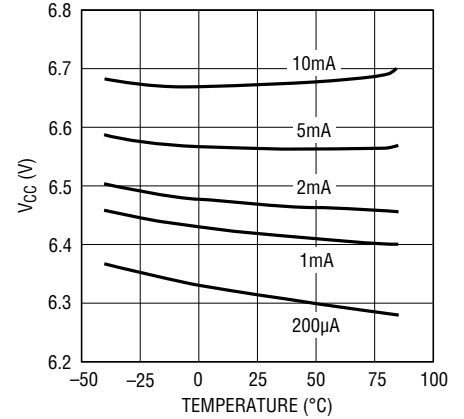

V_{CC} Shunt Voltage vs I_{CC}

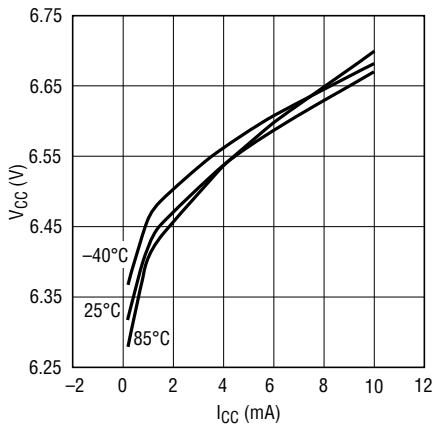

Typical Transient Duration vs Comparator Overdrive

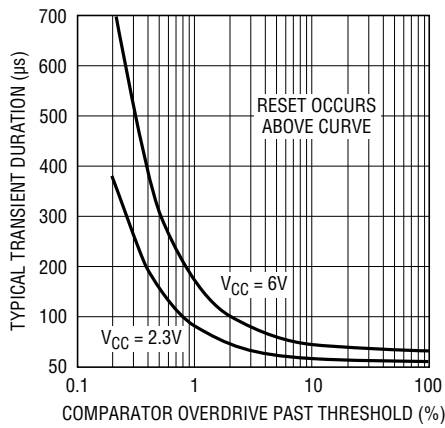

UV Output Voltage vs V_{CC}

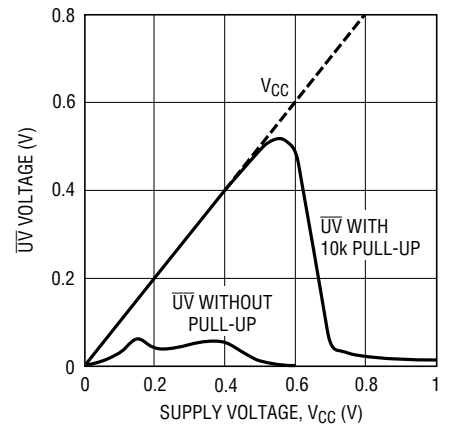

TYPICAL PERFORMANCE CHARACTERISTICS

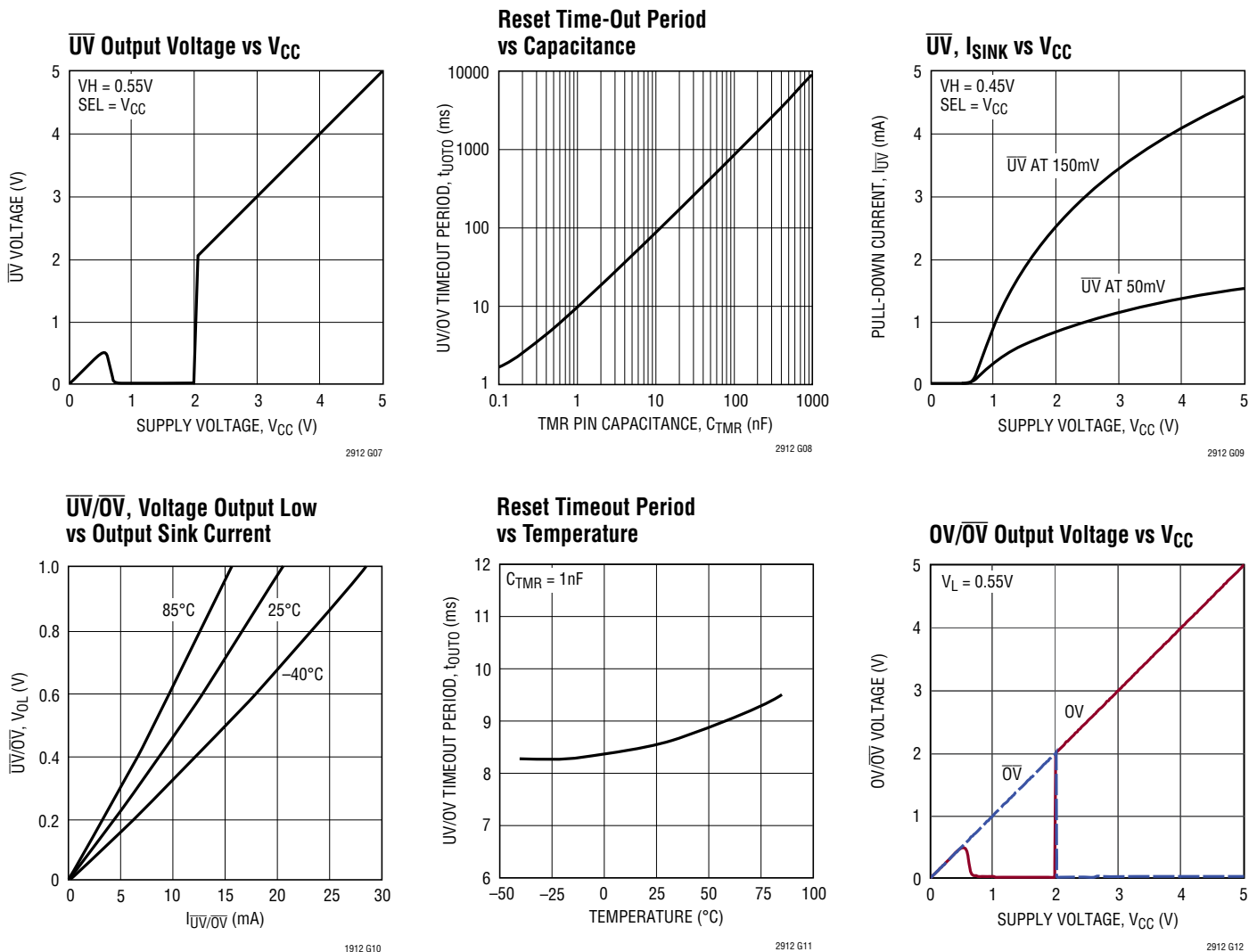

PIN FUNCTIONS (DFN/TSOT Packages)

DIS (Pin 8/Pin 1, LTC2912-2): Output Disable Input. Disables the \overline{OV} and \overline{UV} output pins. When DIS is pulled high, the \overline{OV} and \overline{UV} pins are not asserted except during a UVLO condition. Pin has a weak (2 μ A) internal pull-down to GND. Leave pin open if unused.

Exposed Pad (Pin 9, DDB Package): Exposed Pad may be left open or connected to device ground.

GND (Pin 5/Pin 4): Device Ground.

LATCH (Pin 8/Pin 1, LTC2912-1, LTC2912-3): $\overline{OV}/\overline{OV}$ Latch Clear/Bypass Input. When pulled high, $\overline{OV}/\overline{OV}$ latch

is cleared. While held high, $\overline{OV}/\overline{OV}$ has a similar delay and output characteristic as \overline{UV} .

\overline{OV} (Pin 6/Pin 3, LTC2912-1, LTC2912-2): Overvoltage Logic Output. Asserts low when the VL input voltage is above threshold. Latched low (LTC2912-1). Held low for programmed delay time after VL input is valid (LTC2912-2). Pin has a weak pull-up to V_{CC} and may be pulled above V_{CC} using an external pull-up. Leave pin open if unused.

PIN FUNCTIONS (DFN/TSOT Packages)

OV (Pin 6/Pin 3, LTC2912-3): Overvoltage Logic Output. Asserts high with a weak internal pull-up to V_{CC} when the VL input is above threshold. Latches high. May be pulled above V_{CC} using an external pull-up. Leave pin open if unused.

TMR (Pin 4/Pin 5): Reset Delay Timer. Attach an external capacitor (C_{TMR}) of at least 10pF to GND to set a reset delay time of 9ms/nF. A 1nF capacitor will generate an 8.5ms reset delay time. Tie pin to V_{CC} to bypass timer.

\overline{UV} (Pin 7/Pin 2): Undervoltage Logic Output. Asserts low when the VH input voltage is below threshold. Held low for a programmed delay time after the VH input is valid. Pin has a weak pull-up to V_{CC} and may be pulled above V_{CC} using an external pull-up. Leave pin open if unused.

V_{CC} (Pin 1/Pin 8): Supply Voltage. Bypass this pin to GND with a 0.1 μ F (or greater) capacitor. Operates as a direct supply input for voltages up to 6V. Operates as a shunt regulator for supply voltages greater than 6V and should have a resistance between the pin and the supply to limit input current to no greater than 10mA. When used without a current-limiting resistance, pin voltage must not exceed 6V.

VH (Pin 2/Pin 7): Voltage High Input. When the voltage on this pin is below 0.5V, an undervoltage condition is triggered. Tie pin to V_{CC} if unused.

VL (Pin 3/Pin 6): Voltage Low Input. When the voltage on this pin is above 0.5V, an overvoltage condition is triggered. Tie pin to GND if unused.

BLOCK DIAGRAM

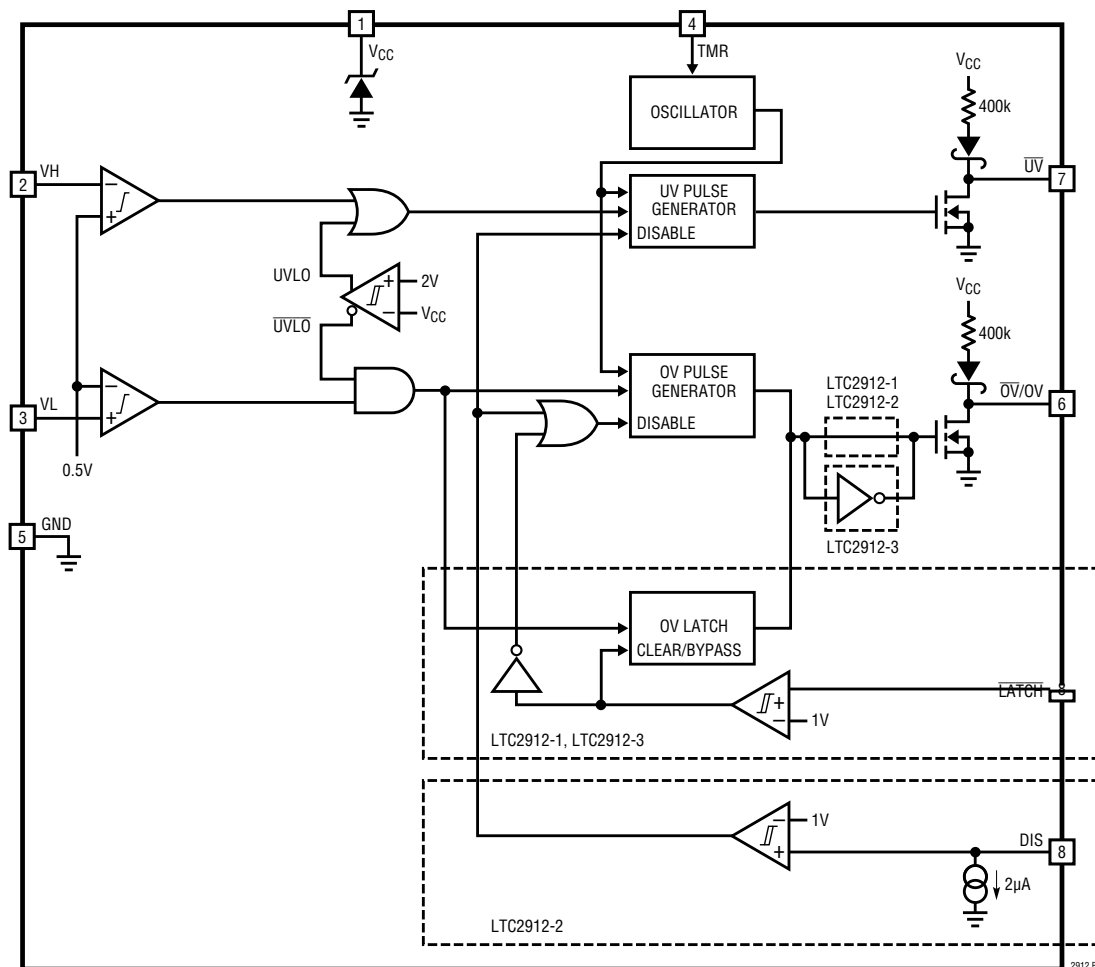

APPLICATIONS INFORMATION

Voltage Monitoring

The LTC2912 is a low power voltage monitoring circuit with an undervoltage and an overvoltage input. A timeout period that holds \overline{OV} and \overline{UV} asserted after a fault has cleared is adjustable using an external capacitor and may be externally disabled. When configured to monitor a positive voltage V_n using the 3-resistor circuit configuration shown in Figure 1, VH will be connected to the high side tap of the resistive divider and VL will be connected to the low side tap of the resistive divider.

3-Step Design Procedure

The following 3-step design procedure allows selecting appropriate resistances to obtain the desired UV and OV trip points for the voltage monitor circuit in Figure 1.

For supply monitoring, V_n is the desired nominal operating voltage, I_n is the desired nominal current through the resistive divider, V_{OV} is the desired overvoltage trip point and V_{UV} is the desired undervoltage trip point.

1. Choose R_A to obtain the desired OV trip point

R_A is chosen to set the desired trip point for the overvoltage monitor.

$$R_A = \left| \frac{0.5V}{I_n} \cdot \frac{V_n}{V_{OV}} \right| \quad (1)$$

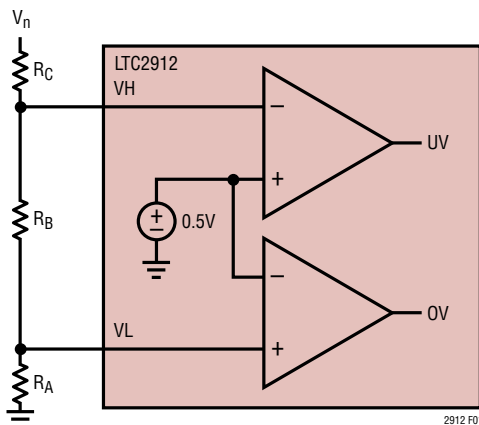

Figure 1. 3-Resistor Positive UV/OV Monitoring Configuration

2. Choose R_B to obtain the desired UV trip point

Once R_A is known, R_B is chosen to set the desired trip point for the undervoltage monitor.

$$R_B = \left| \frac{0.5V}{I_n} \cdot \frac{V_n}{V_{UV}} \right| - R_A \quad (2)$$

3. Choose R_C to complete the design

Once R_A and R_B are known, R_C is determined by:

$$R_C = \left| \frac{V_n}{I_n} \right| - R_A - R_B \quad (3)$$

If any of the variables V_n , I_n , V_{UV} or V_{OV} change, then each step must be recalculated.

Voltage Monitor Example

A typical voltage monitor application is shown in Figure 2. The monitored voltage is a $5V \pm 10\%$ supply. Nominal current in the resistive divider is $10\mu A$.

1. Find R_A to set the OV trip point of the monitor.

$$R_A = \left| \frac{0.5V}{10\mu A} \cdot \frac{5V}{5.5V} \right| \approx 45.3k$$

2. Find R_B to set the UV trip point of the monitor.

$$R_B = \left| \frac{0.5V}{10\mu A} \cdot \frac{5V}{4.5V} \right| - 45.3k \approx 10.2k$$

3. Determine R_C to complete the design.

$$R_C = \left| \frac{5V}{10\mu A} \right| - 45.3k - 10.2k \approx 442k$$

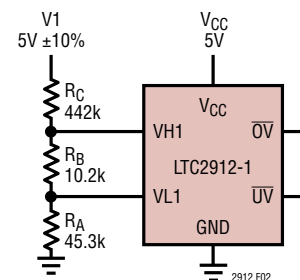

Figure 2. Typical Supply Monitor

APPLICATIONS INFORMATION

Power-Up/Power-Down

As soon as V_{CC} reaches 1V during power up, the \overline{UV} output asserts low and the \overline{OV} output weakly pulls to V_{CC} .

The LTC2912 is guaranteed to assert \overline{UV} low, \overline{OV} high (LTC2912-1, LTC2912-2) and OV low (LTC2912-3) under conditions of low V_{CC} , down to $V_{CC} = 1V$. Above $V_{CC} = 2V$ (2.1V maximum), the VH and VL inputs take control.

Once the VH input and V_{CC} become valid an internal timer is started. After an adjustable delay time, \overline{UV} weakly pulls high.

Threshold Accuracy

Reset threshold accuracy is important in a supply-sensitive system. Ideally, such a system resets only if supply voltages fall outside the exact thresholds for a specified margin. Both LTC2912 inputs have a relative threshold accuracy of $\pm 1.5\%$ over the full operating temperature range.

For example, when the LTC2912 is programmed to monitor a 5V input with a 10% tolerance, the desired UV trip point is 4.5V. Because of the $\pm 1.5\%$ relative accuracy of the LTC2912, the UV trip point can be anywhere between 4.433V and 4.567V which is $4.5V \pm 1.5\%$.

Likewise, the accuracy of the resistances chosen for R_A , R_B and R_C can affect the UV and OV trip points as well. Using the example just given, if the resistances used to set the UV trip point have 1% accuracy, the UV trip range is between 4.354V and 4.650V. This is illustrated in the following calculations.

The UV trip point is given as:

$$V_{UV} = 0.5V \left(1 + \frac{R_C}{R_A + R_B} \right)$$

The two extreme conditions, with a relative accuracy of 1.5% and resistance accuracy of 1%, result in:

$$V_{UV(MIN)} = 0.5V \cdot 0.985 \cdot \left(1 + \frac{R_C \cdot 0.99}{(R_A + R_B) \cdot 1.01} \right)$$

and

$$V_{UV(MAX)} = 0.5V \cdot 1.015 \cdot \left(1 + \frac{R_C \cdot 1.01}{(R_A + R_B) \cdot 0.99} \right)$$

For a desired trip point of 4.5V, $\frac{R_C}{R_A + R_B} = 8$

Therefore,

$$V_{UV(MIN)} = 0.5V \cdot 0.985 \cdot \left(1 + 8 \frac{0.99}{1.01} \right) = 4.354V$$

and

$$V_{UV(MAX)} = 0.5V \cdot 1.015 \cdot \left(1 + 8 \frac{1.01}{0.99} \right) = 4.650V$$

Glitch Immunity

In any supervisory application, noise riding on the monitored DC voltage causes spurious resets. To solve this problem without adding hysteresis, which causes a new error term in the trip voltage, the LTC2912 lowpass filters the output of the first stage comparator at each input. This filter integrates the output of the comparator before asserting the UV or OV logic. A transient at the input of the comparator of sufficient magnitude and duration triggers the output logic. The Typical Performance Characteristics show a graph of the Transient Duration vs Comparator Overdrive.

UV/OV Timing

The LTC2912 has an adjustable timeout period (t_{UOTO}) that holds OV, \overline{OV} or \overline{UV} asserted after each fault has cleared. This delay assures a minimum reset pulse width allowing settling time for the monitored voltage after it has entered the "valid" region of operation.

APPLICATIONS INFORMATION

When the VH input drops below its designed threshold, the \overline{UV} pin asserts low. When the input recovers above its designed threshold, the UV output timer starts. If the input remains above the designed threshold when the timer finishes, the \overline{UV} pin weakly pulls high. However, if the input falls below its designed threshold during this timeout period, the timer resets and restarts when the input is above the designed threshold. The OV and \overline{OV} outputs behave as the \overline{UV} output when \overline{LATCH} is high (LTC2912-1, LTC2912-3).

Selecting the UV/OV Timing Capacitor

The UV and OV timeout period (t_{UOTO}) for the LTC2912 is adjustable to accommodate a variety of applications. Connecting a capacitor, C_{TMR} , between the TMR pin and ground sets the timeout period. The value of capacitor needed for a particular timeout period is:

$$C_{TMR} = t_{UOTO} \cdot 115 \cdot 10^{-9} \text{ [F/s]}$$

The Reset Timeout Period vs Capacitance graph found in the Typical Performance Characteristics shows the desired delay time as a function of the value of the timer capacitor that must be used. The TMR pin must have a minimum 10pF load or be tied to V_{CC} . For long timeout periods, the only limitation is the availability of a large value capacitor with low leakage. Capacitor leakage current must not exceed the minimum TMR charging current of 1.3 μ A. Tying the TMR pin to V_{CC} bypasses the timeout period.

Undervoltage Lockout

When V_{CC} falls below 2V, the LTC2912 asserts an undervoltage lockout (UVLO) condition. During UVLO, \overline{UV} is asserted and pulled low while OV and \overline{OV} are cleared and blocked from asserting. When V_{CC} rises above 2V, \overline{UV} follows the same timing procedure as an undervoltage condition on the VH input.

Shunt Regulator

The LTC2912 has an internal shunt regulator. The V_{CC} pin operates as a direct supply input for voltages up to 6V. Under this condition, the quiescent current of the device remains below a maximum of 70 μ A. For V_{CC} voltages higher than 6V, the device operates as a shunt regulator

and should have a resistance R_Z between the supply and the V_{CC} pin to limit the current to no greater than 10mA.

When choosing this resistance value, select an appropriate location on the I-V curve shown in the Typical Performance Characteristics to accommodate any variations in V_{CC} due to changes in current through R_Z .

\overline{UV} , \overline{OV} and OV Output Characteristics

The DC characteristics of the \overline{UV} , \overline{OV} and OV pull-up and pull-down strength are shown in the Typical Performance Characteristics. Each pin has a weak internal pull-up to V_{CC} and a strong pull-down to ground. This arrangement allows these pins to have open-drain behavior while possessing several other beneficial characteristics. The weak pull-up eliminates the need for an external pull-up resistor when the rise time on the pin is not critical. On the other hand, the open-drain configuration allows for wired-OR connections, and is useful when more than one signal needs to pull down on the output. V_{CC} of 1V guarantees a maximum $V_{OL} = 0.15V$ at \overline{UV} .

At $V_{CC} = 1V$, the weak pull-up current on \overline{OV} is barely turned on. Therefore, an external pull-up resistor of no more than 100k is recommended on the \overline{OV} pin if the state and pull-up strength of the \overline{OV} pin is crucial at very low V_{CC} .

Note however, by adding an external pull-up resistor, the pull-up strength on the \overline{OV} pin is increased. Therefore, if it is connected in a wired-OR connection, the pull-down strength of any single device must accommodate this additional pull-up strength.

Output Rise and Fall Time Estimation

The \overline{UV} , \overline{OV} and OV outputs have strong pull-down capability. The following formula estimates the output fall time (90% to 10%) for a particular external load capacitance (C_{LOAD}):

$$t_{FALL} \approx 2.2 \cdot R_{PD} \cdot C_{LOAD}$$

where R_{PD} is the on-resistance of the internal pull-down transistor, typically 50 Ω at $V_{CC} > 1V$ and at room temperature (25°C). C_{LOAD} is the external load capacitance on the pin. Assuming a 150pF load capacitance, the fall time is 16.5ns.

APPLICATIONS INFORMATION

The rise time on the \overline{UV} , \overline{OV} and OV pins is limited by a 400k pull-up resistance to V_{CC} . A similar formula estimates the output rise time (10% to 90%) at the \overline{UV} , \overline{OV} and OV pins:

$$t_{RISE} \approx 2.2 \cdot R_{PU} \cdot C_{LOAD}$$

where R_{PU} is the pull-up resistance.

\overline{OV}/OV Latch (LTC2912-1, LTC2912-3)

With the \overline{LATCH} pin held low, the \overline{OV} pin latches low (LTC2912-1) and the OV pin latches high (LTC2912-3) when an OV condition is detected. The latch is cleared by raising the \overline{LATCH} pin high. If an OV condition clears while \overline{LATCH} is held high, the latch is bypassed and the OV and \overline{OV} pins behave the same as the \overline{UV} pin with a similar timeout period at the output. If \overline{LATCH} is pulled

low while the timeout period is active, the OV and \overline{OV} pins latch as before.

Disable (LTC2912-2)

The LTC2912-2 allows disabling the \overline{UV} and \overline{OV} outputs via the DIS pin. Pulling DIS high forces both outputs to remain weakly pulled high, regardless of any faults that occur on the inputs. However, if a UVLO condition occurs, \overline{UV} asserts and pulls low, but the timeout function is bypassed. \overline{UV} pulls high as soon as the UVLO condition is cleared.

DIS has a weak $2\mu A$ (typical) internal pull-down current guaranteeing normal operation with the pin left open.

TYPICAL APPLICATIONS

Dual UV/OV Supply Monitor, 3.3V $\pm 10\%$ Tolerance

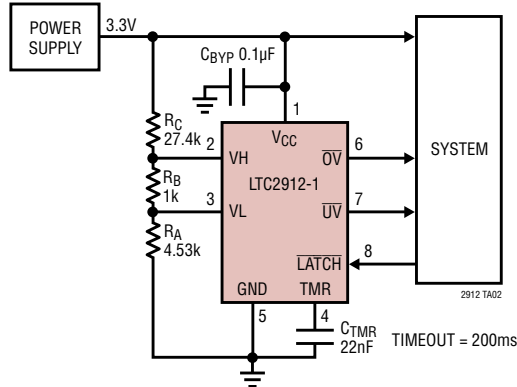

48V Supply Monitor ($\pm 10\%$ = Powergood)

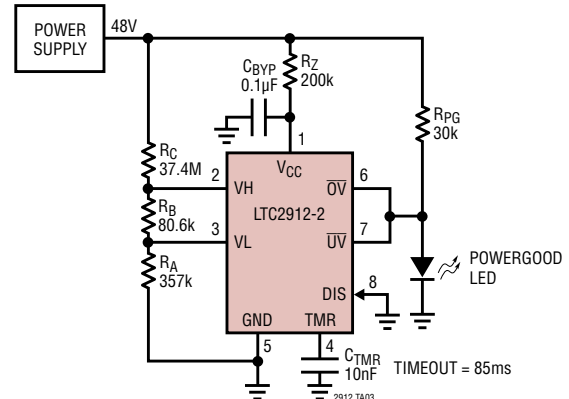

Dual UV Supply Monitor, 3.3V, 2.5V, 10% Tolerance

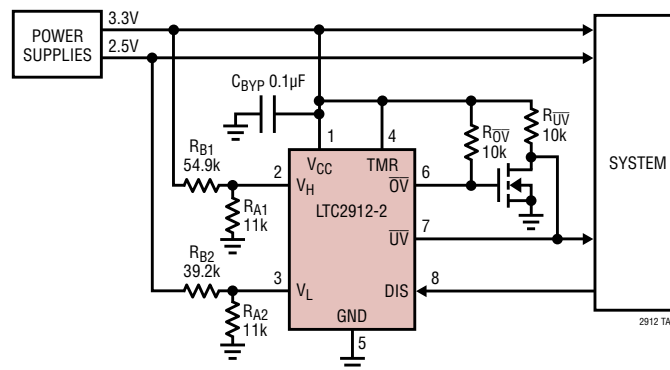

PACKAGE DESCRIPTION

DDB Package 8-Lead Plastic DFN (3mm × 2mm) (Reference LTC DWG # 05-08-1702 Rev B)

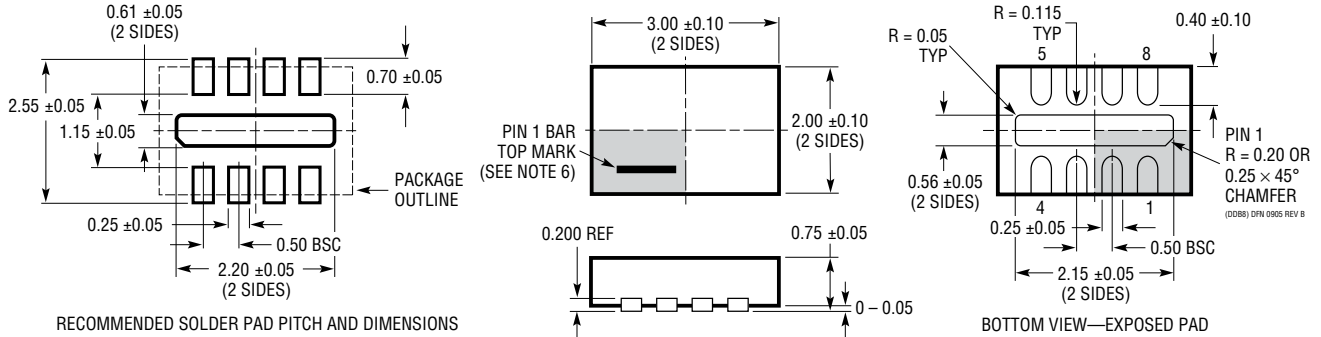

RECOMMENDED SOLDER PAD PITCH AND DIMENSIONS

NOTE:

1. DRAWING CONFORMS TO VERSION (WECD-1) IN JEDEC PACKAGE OUTLINE MO-229
2. DRAWING NOT TO SCALE
3. ALL DIMENSIONS ARE IN MILLIMETERS
4. DIMENSIONS OF EXPOSED PAD ON BOTTOM OF PACKAGE DO NOT INCLUDE MOLD FLASH. MOLD FLASH, IF PRESENT, SHALL NOT EXCEED 0.15mm ON ANY SIDE
5. EXPOSED PAD SHALL BE SOLDER PLATED
6. SHADED AREA IS ONLY A REFERENCE FOR PIN 1 LOCATION ON THE TOP AND BOTTOM OF PACKAGE

TS8 Package 8-Lead Plastic TSOT-23 (Reference LTC DWG # 05-08-1637 Rev A)

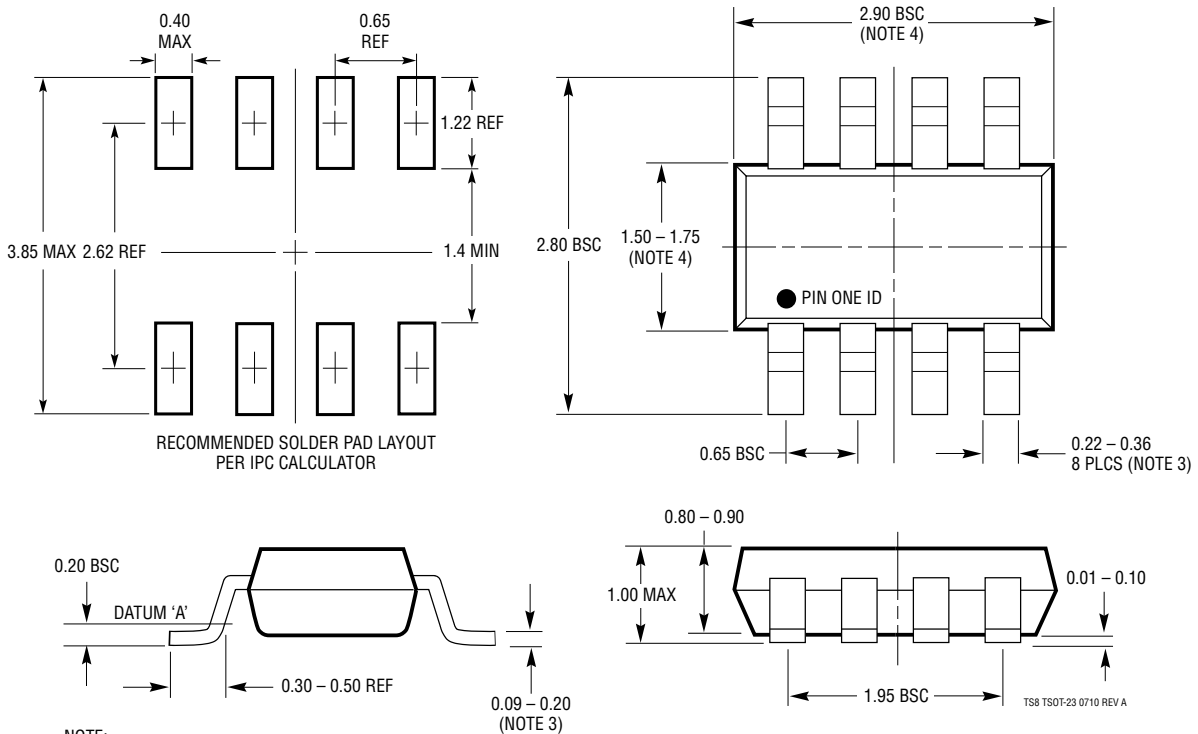

NOTE:

1. DIMENSIONS ARE IN MILLIMETERS
2. DRAWING NOT TO SCALE
3. DIMENSIONS ARE INCLUSIVE OF PLATING
4. DIMENSIONS ARE EXCLUSIVE OF MOLD FLASH AND METAL BURR
5. MOLD FLASH SHALL NOT EXCEED 0.254mm
6. JEDEC PACKAGE REFERENCE IS MO-193

REVISION HISTORY (Revision history begins at Rev B)

REV	DATE	DESCRIPTION	PAGE NUMBER
B	06/14	Updated Package/Order Information Added OV/ \overline{OV} Output Voltage vs V_{CC} graph	2, 3 6
C	02/20	Corrected T_{JMAX} or θ_{JA} for TSOT-23 package	2

TYPICAL APPLICATION

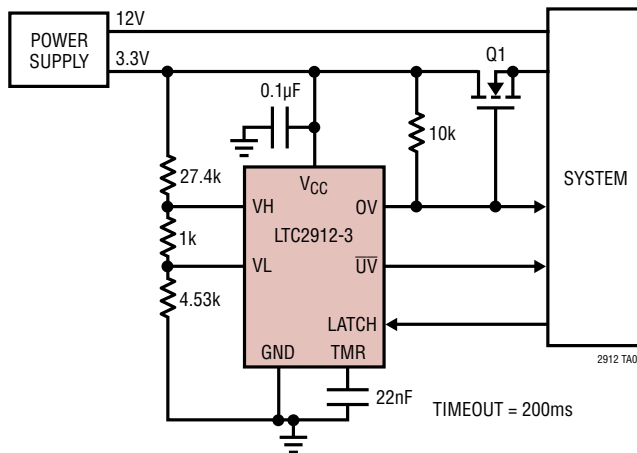

Single UV/OV Supply Monitor with 3.3V $\pm 10\%$ 

RELATED PARTS

PART NUMBER	DESCRIPTION	COMMENTS
LTC690	5V Supply Monitor, Watchdog Timer and Battery Backup	4.65 Threshold
LTC694-3.3	3.3V Supply Monitor, Watchdog Timer and Battery Backup	2.9V Threshold
LTC699	5V Supply Monitor and Watchdog Timer	4.65 Threshold
LTC1232	5V Supply Monitor, Watchdog Timer and Push-Button Reset	4.37V/4.62V Threshold
LTC1326/ LTC1326-2.5	Micropower Precision Triple Supply Monitor for 5V/2.5V, 3.3V and ADJ	4.725V, 3.118V, 1V Threshold ($\pm 0.75\%$)
LTC1536	Precision Triple Supply Monitor for PCI Applications	Meets PCI t_{FAIL} Timing Specifications
LTC1726-2.5/ LTC1726-5	Micropower Triple Supply Monitor for 2.5V/5V, 3.3V and ADJ	Adjustable \overline{RESET} and Watchdog Time-Outs
LTC1728-1.8/ LTC1728-3.3	Micropower Triple Supply Monitor with Open-Drain Reset	5-Lead SOT-23 Package
LTC1985-1.8	Micropower Triple Supply Monitor with Open-Drain Reset	5-Lead SOT-23 Package
LTC2900	Programmable Quad Supply Monitor	Adjustable RESET, 10-Lead MSOP and 3mm \times 3mm 10-Lead DFN Package
LTC2901	Programmable Quad Supply Monitor	Adjustable RESET and Watchdog Timer, 16-Lead SSOP Package
LTC2902	Programmable Quad Supply Monitor	Adjustable RESET and Tolerance, 16-Lead SSOP Package, Margining Functions
LTC2903-1	Precision Quad Supply Monitor	6-Lead TSOT-23 Package, Ultralow Voltage Reset
LTC2904	3-State Programmable Precision Dual Supply Monitor	Adjustable Tolerance, 8-Lead TSOT-23 Package
LTC2905	3-State Programmable Precision Dual Supply Monitor	Adjustable RESET and Tolerance, 8-Lead TSOT-23 Package
LTC2906	Precision Dual Supply Monitor 1-Selectable and 1 Adjustable	Separate V_{CC} Pin, RST/ \overline{RST} Outputs
LTC2907	Precision Dual Supply Monitor 1-Selectable and 1 Adjustable	Separate V_{CC} , Adjustable Reset Timer
LTC2908	Precision Six Supply Monitor (Four Fixed and 2 Adjustable)	8-Lead TSOT-23 and DFN Packages
LTC2909	Prevision Dual Input UV, OV and Negative Voltage Monitor	Separate V_{CC} Pin, Adjustable Reset Timer, 8-Lead TSOT-23 and DFN Packages
LTC2913	Dual UV/OV Voltage Monitor	Separate V_{CC} Pin, Two Inputs, Adjustable Reset Timer, 10-Lead MSOP and DFN Packages
LTC2914	Quad UV/OV Positive/Negative Voltage Monitor	Separate V_{CC} Pin, Four inputs, Up To Two Negative Monitors, Adjustable Reset Timer, 16-Lead TSSOP and DFN Packages

Looking for pricing, stock, or lifecycle information?

Click below to explore more details on WIN SOURCE:

-  [View LTC2912HDDDB-1#TRMPBF on WIN SOURCE](#)
-  [Analog Devices Inc. Information](#)

Optimize Your Supply Chain with WIN SOURCE Solutions

-  Global Sourcing Solution
-  Obsolete Management
-  Cost Control Management
-  Shortage Management
-  Alternative Solution
-  Excess Inventory Management