



**THE DATASHEET OF
MAX15090BEWI+T**



MAX15090B/MAX15090C

General Description

The MAX15090B/MAX15090C ICs are integrated solutions for hot-swap applications requiring the safe insertion and removal of circuit line cards from a live backplane. The devices integrate a hot-swap controller, 6mΩ power MOSFET, and an electronic circuit-breaker protection in a single package.

The devices integrate an accurate current-sense circuitry and provide 220μA/A of proportional output current. The devices are designed for protection of 2.7V to 18V supply voltages.

These devices implement a foldback current limit during startup to control inrush current lowering di/dt and keep the MOSFET operating under safe operating area (SOA) conditions. After the startup cycle is complete, on-chip comparators provide VariableSpeed/BiLevel™ protection against short-circuit and overcurrent faults, and immunity against system noise and load transients. The load is disconnected in the event of a fault condition. The devices are factory calibrated to deliver accurate overcurrent protection with ±10% accuracy. During a fault condition, the MAX15090B latches off, while the MAX15090C enters autoretry mode.

The devices feature an IN-to-OUT short-circuit detection before startup. The devices provide a power-MOSFET GATE pin to program the slew rate during startup by adding an external capacitor. The devices have overvoltage/undervoltage input pins that can detect an overvoltage/undervoltage fault and disconnect the IN from the OUT. Additional features include internal overtemperature protection, power-good output, and fault-indicator output.

The MAX15090B/MAX15090C ICs are available in a 28-bump, 2.07mm x 3.53mm, power wafer-level package (WLP) and are rated over the -40°C to +85°C extended temperature range.

Applications

- RAID Systems
- Storage Bridge Bay
- Disk Drive Power
- Server I/O Cards
- Industrial

VariableSpeed/BiLevel is a trademark of Maxim Integrated Products, Inc.

2.7V to 18V, 12A, Hot-Swap Solution with Current Report Output

Benefits and Features

- Integration Reduces Solution Size for Blade Servers and Other Space-Constrained Designs
 - Integrated 6mΩ (typ) Internal Power MOSFET
 - Overvoltage Protection
 - Power-Good and Fault Outputs
 - Programmable Undervoltage Lockout
 - Current Reporting Without Need for External RSENSE
 - Thermal Protection
- Flexibility Enables Use in Many Unique Designs
 - 2.7V to 18V Operating Voltage Range
 - Adjustable Circuit-Breaker Current/Current-Limit Threshold
 - Programmable Slew-Rate Control
 - Variable-Speed Circuit-Breaker Response
 - Latchoff or Automatic Retry Options
- Safety Features Ensure Accurate, Robust Protection
 - 12A (max) Load Current Capability
 - ±10% Circuit-Breaker Threshold Accuracy
 - Inrush Current Regulated at Startup with Foldback
 - Implementation for di/dt Control
 - IN-to-OUT Short-Circuit Detection

[Ordering Information and Recommended Application Circuit for Hot-Swap Applications appear at end of data sheet.](#)

Typical Application Circuit

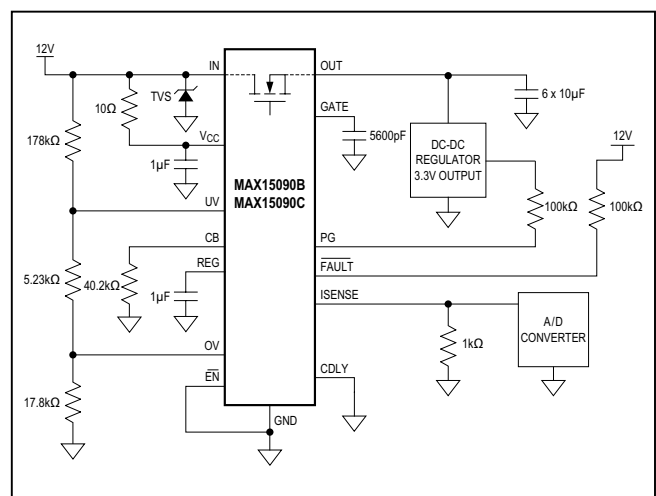

Absolute Maximum Ratings

| | | | |
|------------------------------|--|---|-----------------|
| V _{CC} to GND | -0.3V to +20V | Continuous Power Dissipation (T _A = +70°C) | |
| IN to GND | -0.3V to +20V | WLP (derate 23.8mW/°C above +70°C) | 1500mW |
| OUT to GND | -0.3V to (V _{IN} + 0.3V) | Operating Temperature Range | -40°C to +85°C |
| GATE to OUT | -0.3V to +6V | Junction Temperature | +150°C |
| CDLY, ISENSE to GND | -0.3V to (V _{REG} + 0.3V) | Storage Temperature Range | -60°C to +150°C |
| EN, CB, UV, OV to GND | -0.3V to +6V | Lead Temperature (soldering, 10s) | +300°C |
| REG to GND | -0.3V to min (+6V, (V _{CC} + 0.3V)) | Soldering Temperature (reflow) | +260°C |
| PG, FAULT to GND | -0.3V to +20V | | |

Stresses beyond those listed under “Absolute Maximum Ratings” may cause permanent damage to the device. These are stress ratings only, and functional operation of the device at these or any other conditions beyond those indicated in the operational sections of the specifications is not implied. Exposure to absolute maximum rating conditions for extended periods may affect device reliability.

Package Thermal Characteristics (Note 1)

| | | | |
|---|--------|--|-------|
| Junction-to-Ambient Thermal Resistance (θ _{JA}) | 42°C/W | Junction-to-Case Thermal Resistance (θ _{JC}) | 7°C/W |
|---|--------|--|-------|

Note 1: Package thermal resistances were obtained using the method described in JEDEC specification JESD51-7, using a four-layer board. For detailed information on package thermal considerations, refer to www.maximintegrated.com/thermal-tutorial. Thermal resistance can be lowered with improved board design.

Electrical Characteristics

(V_{IN} = V_{CC} = 2.7V to 18V, T_A = T_J = -40°C to +85°C, unless otherwise noted. Typical values are at V_{IN} = 12V, R_{CB} = 33.2kΩ, and T_A = +25°C.) (Note 2)

| PARAMETER | SYMBOL | CONDITIONS | MIN | TYP | MAX | UNITS |
|---|-----------------------|-----------------------------------|------|------|------|-------|
| POWER SUPPLIES | | | | | | |
| V _{CC} Operating Range | V _{CC} | | 2.7 | | 18 | V |
| IN Operating Range | V _{IN} | | 2.7 | | 18 | V |
| V _{CC} Supply Current | I _{CC} | V _{IN} = 3V | | 0.5 | 0.75 | mA |
| IN Supply Current | I _{IN} | R _{CB} = 40.2kΩ, no load | | 5.25 | 6.2 | mA |
| | | R _{CB} = 10kΩ, no load | | 1.5 | 2.4 | |
| V _{CC} Default Undervoltage Lockout | V _{UVLO} | V _{CC} rising | 2.35 | 2.5 | 2.65 | V |
| V _{CC} Default Undervoltage-Lockout Hysteresis | V _{UVLO_HYS} | | | 0.1 | | V |
| REG Regulator Voltage | V _{REG} | No load, V _{CC} > 4V | 3.15 | 3.35 | 3.55 | V |
| UV Turn-On Threshold | V _{UV_TH} | V _{UV} rising | 1.21 | 1.23 | 1.25 | V |
| UV Turn-On Threshold Hysteresis | V _{UV_HYS} | V _{UV} falling | | 0.1 | | V |
| OV Turn-On Threshold | V _{OV_TH} | V _{OV} rising | 1.21 | 1.23 | 1.25 | V |
| OV Turn-On Threshold Hysteresis | V _{OV_HYS} | V _{OV} falling | | 0.1 | | V |
| EN Threshold | V _{EN_TH} | V _{EN} rising | 0.95 | 1 | 1.05 | V |
| EN Threshold Hysteresis | V _{EN_HYS} | V _{EN} falling | | 0.1 | | V |

Electrical Characteristics (continued)

($V_{IN} = V_{CC} = 2.7V$ to $18V$, $T_A = T_J = -40^{\circ}C$ to $+85^{\circ}C$, unless otherwise noted. Typical values are at $V_{IN} = 12V$, $R_{CB} = 33.2k\Omega$, and $T_A = +25^{\circ}C$.) (Note 2)

| PARAMETER | SYMBOL | CONDITIONS | MIN | TYP | MAX | UNITS | |
|---|------------------|---|------------------------|------------------------|-------|------------|---|
| OV, UV, \overline{EN} Input Leakage Current | I_{LEAK} | $V_{OV} = V_{UV} = V_{\overline{EN}} = 0$ to $5V$ | -1 | | +1 | μA | |
| CB Source Current | I_{THCB_NORM} | Power-on mode | | 12 | | μA | |
| CURRENT LIMIT | | | | | | | |
| Circuit-Breaker Accuracy (Note 3) | $I_{CB,TH}$ | $V_{IN} = 12V$ | $R_{CB} = 40.2k\Omega$ | 10.85 | 12.06 | 13.27 | A |
| | | | $R_{CB} = 10k\Omega$ | 2.7 | 3 | 3.3 | |
| Circuit-Breaker Accuracy Deviation | | $R_{CB} = 10k\Omega$ to $40.2k\Omega$, compared to nominal current-limit value | -10 | | +10 | % | |
| Slow-Comparator Response Time (Note 4) | t_{SCD} | 0.6% overcurrent | | 1.5 | | ms | |
| | | 30% overcurrent | | 200 | | μs | |
| Maximum Current Limit During Startup | I_{LIM_MAX} | (see Figure 2) | | $0.5 \times I_{CB,TH}$ | | A | |
| Fast-Comparator Threshold | I_{FC_TH} | | | $1.5 \times I_{CB,TH}$ | | A | |
| Minimum CB Voltage Reference During Foldback (Note 5) | V_{THCB_MIN} | $V_{IN} - V_{OUT} > 10V$, $R_{CB} = 40.2k\Omega$ | | 60 | | mV | |
| Maximum CB Voltage Reference During Foldback (Note 5) | V_{THCB_MAX} | $V_{IN} - V_{OUT} < 2V$, $R_{CB} = 40.2k\Omega$ | | 240 | | mV | |
| TIMING | | | | | | | |
| Startup Maximum Time Duration | t_{SU} | | 43 | 48 | 53 | ms | |
| Autorestart Delay Time | $t_{RESTART}$ | | | 3.2 | | s | |
| Time Delay Comparator High Threshold | V_{DLY_TH} | | 1.85 | 2 | 2.18 | V | |
| Time Delay Pullup Current | I_{DLY} | | 1.6 | 1.9 | 2.3 | μA | |
| Output Short Detection at Startup | t_{SHORT} | | 10.8 | 13 | 14.4 | ms | |
| MOSFET | | | | | | | |
| Total On-Resistance | R_{ON} | $T_A = +25^{\circ}C$ | | 5.5 | 7.5 | m Ω | |
| | | $T_A = -40^{\circ}C$ to $+85^{\circ}C$ | | | 9 | | |
| GATE Charge Current | I_{GATE} | | 4.4 | 5.7 | 7.5 | μA | |

Electrical Characteristics (continued)

($V_{IN} = V_{CC} = 2.7V$ to $18V$, $T_A = T_J = -40^{\circ}C$ to $+85^{\circ}C$, unless otherwise noted. Typical values are at $V_{IN} = 12V$, $R_{CB} = 33.2k\Omega$, and $T_A = +25^{\circ}C$.) (Note 2)

| PARAMETER | SYMBOL | CONDITIONS | MIN | TYP | MAX | UNITS |
|---|---------------------|---|------|---------------------|------|-------------|
| OUTPUTS | | | | | | |
| \overline{FAULT} , PG Output Low Voltage | V_{OL} | Low-impedance state, $I_{\overline{FAULT}} = +5mA$, $I_{PG} = +5mA$ | | | 0.4 | V |
| \overline{FAULT} , PG Output High Leakage Current | I_{OH} | High-impedance state, $V_{\overline{FAULT}} = 16V$, $V_{PG} = 16V$ | | | 1 | μA |
| CURRENT REPORT | | | | | | |
| ISENSE Full-Scale Current | I_{ISENSE} | | | 2.64 | | mA |
| ISENSE Gain Ratio | | I_{ISENSE}/I_{OUT} | | 220 | | $\mu A/A$ |
| ISENSE Voltage Range | V_{ISENSE} | $V_{IN} = 12V$ | 0 | | 2.5 | V |
| ISENSE Offset Error | I_{ISENSE_OFF} | $T_A = +25^{\circ}C$ | -30 | | +30 | μA |
| | | $T_A = -40^{\circ}C$ to $+85^{\circ}C$ | -65 | | +65 | |
| ISENSE Differential Gain Error | I_{ISENSE_ERROR} | $T_A = +25^{\circ}C$, $I_{OUT} = 1A$, $\Delta I_{OUT} = 100mA$ | -2.5 | | +2.5 | % |
| | | $T_A = -40^{\circ}C$ to $+85^{\circ}C$, $I_{OUT} = 1A$, $\Delta I_{OUT} = 100mA$ | -4 | | +4 | |
| PG THRESHOLD | | | | | | |
| PG Threshold | V_{PG} | Measured at V_{OUT} | | $0.9 \times V_{IN}$ | | V |
| PG Assertion Delay | t_{PG} | From $V_{OUT} > V_{PG}$ and $(V_{GATE} - V_{IN}) > 3V$ | 12 | 16 | 20 | ms |
| OUT to IN Short-Circuit Detection Threshold | V_{IOSHT} | Measured at V_{OUT} | | $0.9 \times V_{IN}$ | | |
| OUT Precharge Threshold | V_{PC} | Measured at V_{OUT} | | $0.5 \times V_{IN}$ | | V |
| THERMAL SHUTDOWN | | | | | | |
| Thermal Shutdown | T_{SD} | T_J rising | | +150 | | $^{\circ}C$ |
| Thermal-Shutdown Hysteresis | | T_J falling | | 20 | | $^{\circ}C$ |

Note 2: All devices are 100% production tested at $T_A = +25^{\circ}C$. Limits over temperature are guaranteed by design.

Note 3: $40.2k\Omega$ is the maximum allowed external resistance value to be connected at CB pin to GND for safe operation. All devices are tested with $10k\Omega$, the parameter specified at $R_{CB} = 40.2k\Omega$ is guaranteed by bench characterization and correlation, with respect to the tested parameter at $R_{CB} = 10k\Omega$. The formula that describes the relationship between R_{CB} and the circuit-breaker current threshold is: $I_{CB} = R_{CB}/3333.3$.

Note 4: The current-limit slow-comparator response time is weighed against the amount of overcurrent so the higher the overcurrent condition, the faster the response time.

Note 5: Foldback is active during the startup phase so the internal power MOSFET operates within SOA.

Typical Operating Characteristics

($V_{IN} = V_{CC} = 2.7V$ to $18V$, $T_J = -40^{\circ}C$ to $+85^{\circ}C$, unless otherwise noted. Typical values are at $V_{IN} = 12V$, $R_{CB} = 33.2k\Omega$, and $T_J = +25^{\circ}C$.) (Note 3)

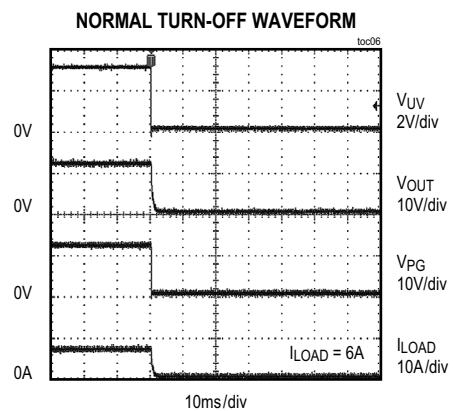
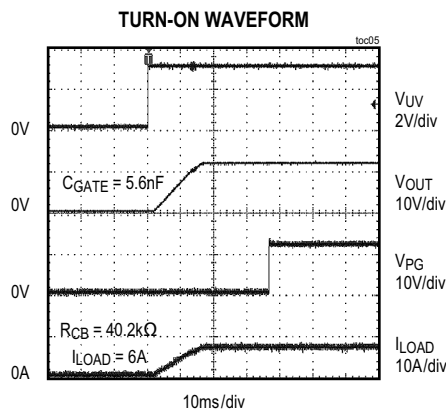
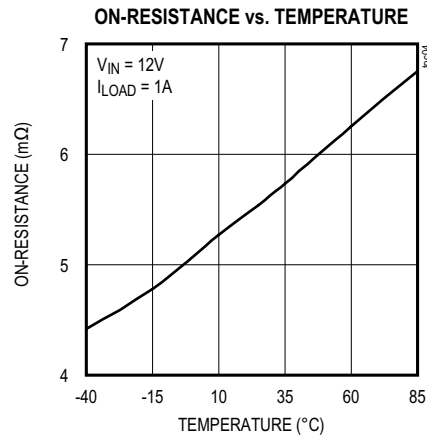
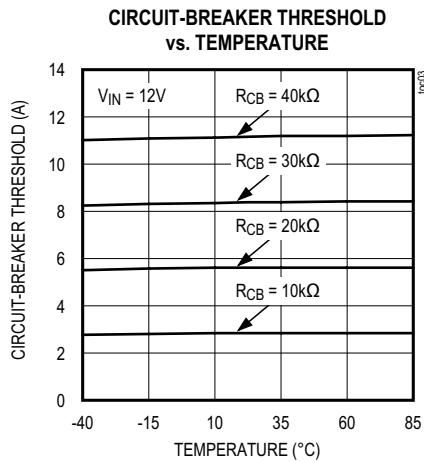
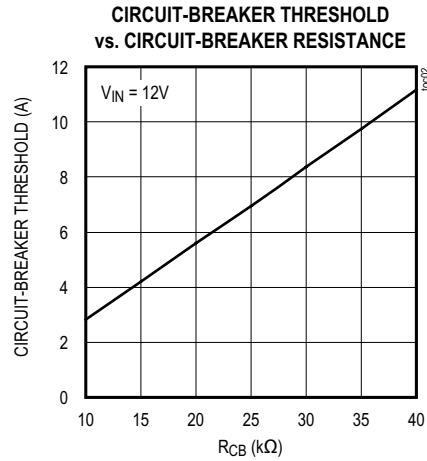
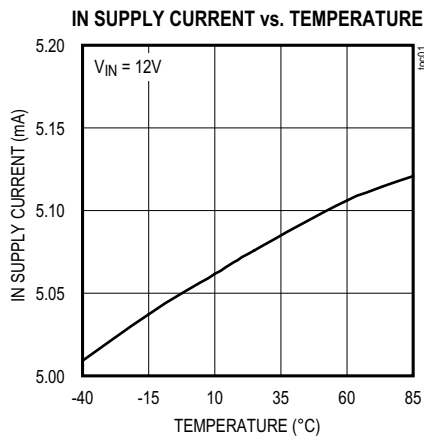

Typical Operating Characteristics (continued)

($V_{IN} = V_{CC} = 2.7V$ to $18V$, $T_J = -40^{\circ}C$ to $+85^{\circ}C$, unless otherwise noted. Typical values are at $V_{IN} = 12V$, $R_{CB} = 33.2k\Omega$, and $T_J = +25^{\circ}C$.) (Note 3)

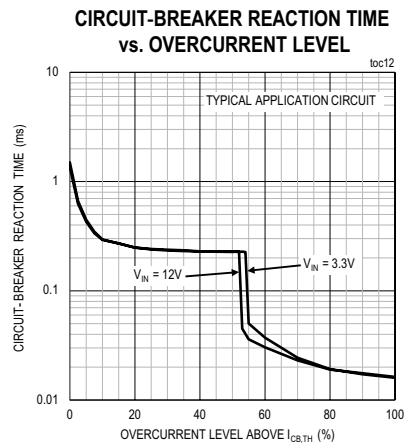
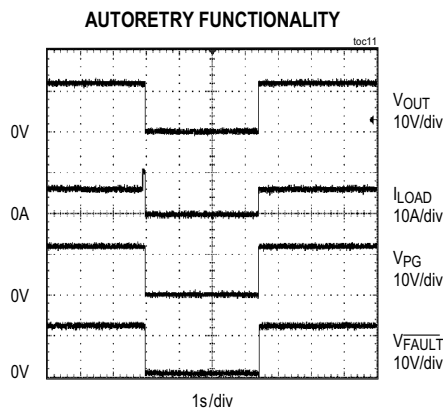
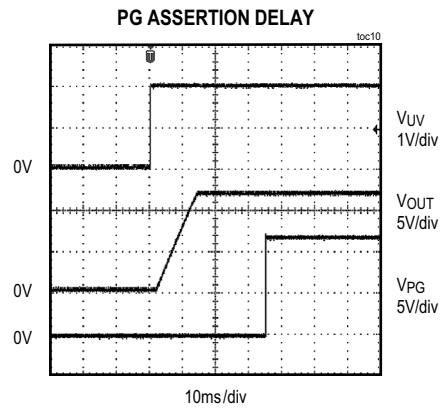
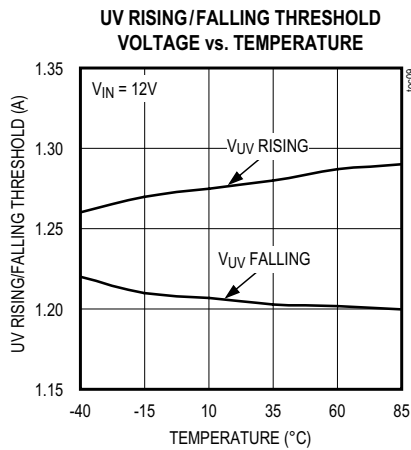
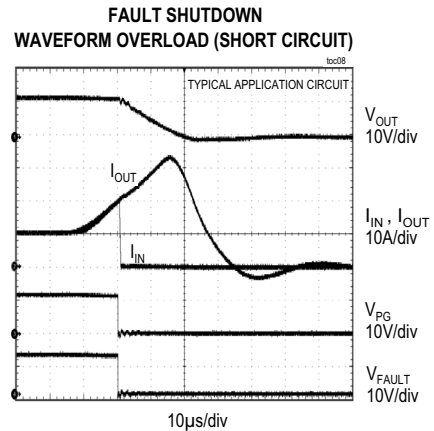
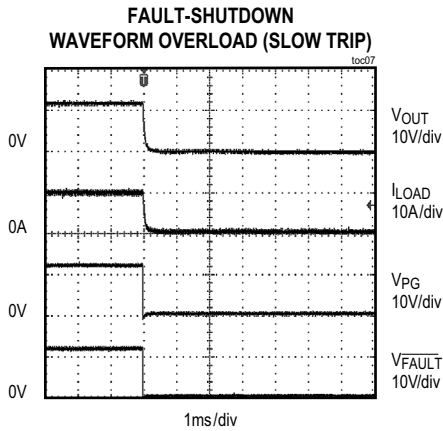

Bump Configuration

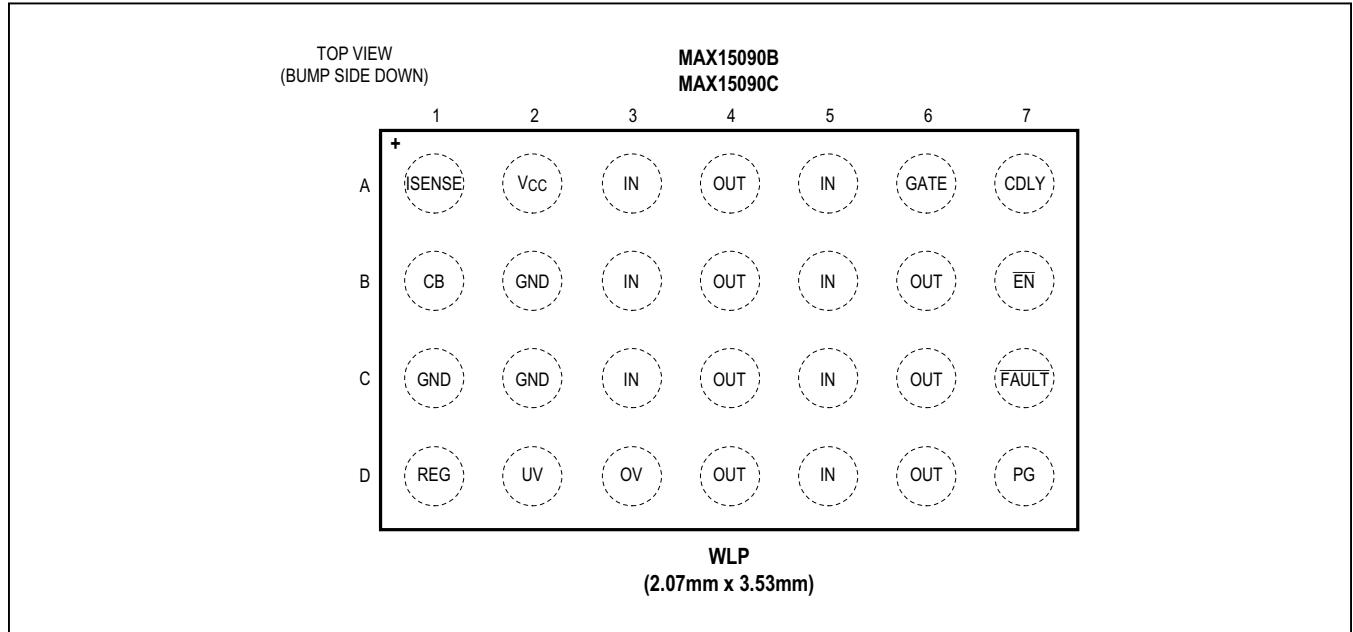

Bump Description

| BUMP | NAME | FUNCTION |
|----------------------------|-----------------|---|
| A1 | ISENSE | Current-Sense Output. The ISENSE output sources a current that is proportional to the output current. Connect a resistor between ISENSE and GND to produce a scaled voltage. |
| A2 | V _{CC} | Power-Supply Input. Connect V _{CC} to a voltage between 2.7V and 18V. Connect a Schottky diode (or 6Ω resistor) from IN to V _{CC} and a 1μF bypass capacitor to GND to guarantee full operation in the event V _{IN} collapses during a strong short from OUT to GND. |
| A3, A5, B3, B5, C3, C5, D5 | IN | Supply Voltage Input. IN is connected to the drain of the internal 6mΩ MOSFET. Bypass IN with a transient voltage-suppressor diode to GND for clamping inductive kick transients in the case of fast output short-circuit to GND. |
| A4, B4, B6, C4, C6, D4, D6 | OUT | Load Output. Source of the internal power MOSFET. |

Bump Description (continued)

| BUMP | NAME | FUNCTION |
|------------|---------------------------|--|
| A6 | GATE | GATE of Internal MOSFET. During startup, a 5.7 μ A current is sourced to enhance the internal MOSFET with a 10V/ms slew rate. Connect an external capacitance from GATE to GND to reduce the output slew rate during startup. |
| A7 | CDLY | Enable Timer Input. Connect a capacitor between CDLY and GND to set a 1s/ μ F duration timeout delay. The $\overline{\text{EN}}$ input has to be pulled low before the timeout delay elapses, to prevent internal MOSFET shutdown after power-up. Minimum required capacitor for CDLY is 1000pF; short to GND if not needed. |
| B1 | CB | Current-Limit Threshold Set. Connect a resistor from CB to GND to set the circuit-breaker threshold. Maximum value of 40.2k Ω can be accepted for safe operation. Having the CB pin connected to GND sets the circuit-breaker threshold at 0A. |
| B2, C1, C2 | GND | Ground |
| B7 | $\overline{\text{EN}}$ | Enable Input. This input does not function like a traditional enable input (see UV description). Externally pulled up to logic-high state through a resistor normally connected to REG. The $\overline{\text{EN}}$ input must be pulled down (for at least 1ms) by the external circuit before a programmable timeout delay has elapsed, otherwise a shutdown occurs. The timeout timer starts counting when the internal MOSFET is turned on. Connect a capacitor between CDLY and GND to program the duration of the timeout delay. Connect $\overline{\text{EN}}$ to GND to disable this feature. |
| C7 | $\overline{\text{FAULT}}$ | Fault Status Output. $\overline{\text{FAULT}}$ is an open-drain, active-low output. See the <i>Fault-Status Output ($\overline{\text{FAULT}}$)</i> section for conditions that make $\overline{\text{FAULT}}$ assert low. $\overline{\text{FAULT}}$ is disabled during startup. |
| D1 | REG | Internal Regulator Output. Bypass to ground with a 1 μ F capacitor. Do not power external circuitry using the REG output (except a resistor > 50k Ω connected from REG to $\overline{\text{EN}}$). Optional: For V_{CC} values lower than $V_{\text{REG_MAX}}$, REG can be connected to V_{CC} to maximize the voltage on the REG pin (see the <i>Electrical Characteristics</i> table). |
| D2 | UV | Active-High Enable Comparator Input. Pulling UV high enables the internal MOSFET to turn on. UV also sets the undervoltage threshold. See the <i>Setting the Undervoltage Threshold</i> section. |
| D3 | OV | Overvoltage Enable Input. Pull OV high to turn off the internal MOSFET. Connect OV to an external resistive divider to set the overvoltage-disable threshold. See the <i>Setting the Overvoltage Threshold</i> section. |
| D7 | PG | Power-Good Output. PG is an open-drain, active-high output. PG pulls low until the internal power MOSFET is fully enhanced. |

Functional Diagram

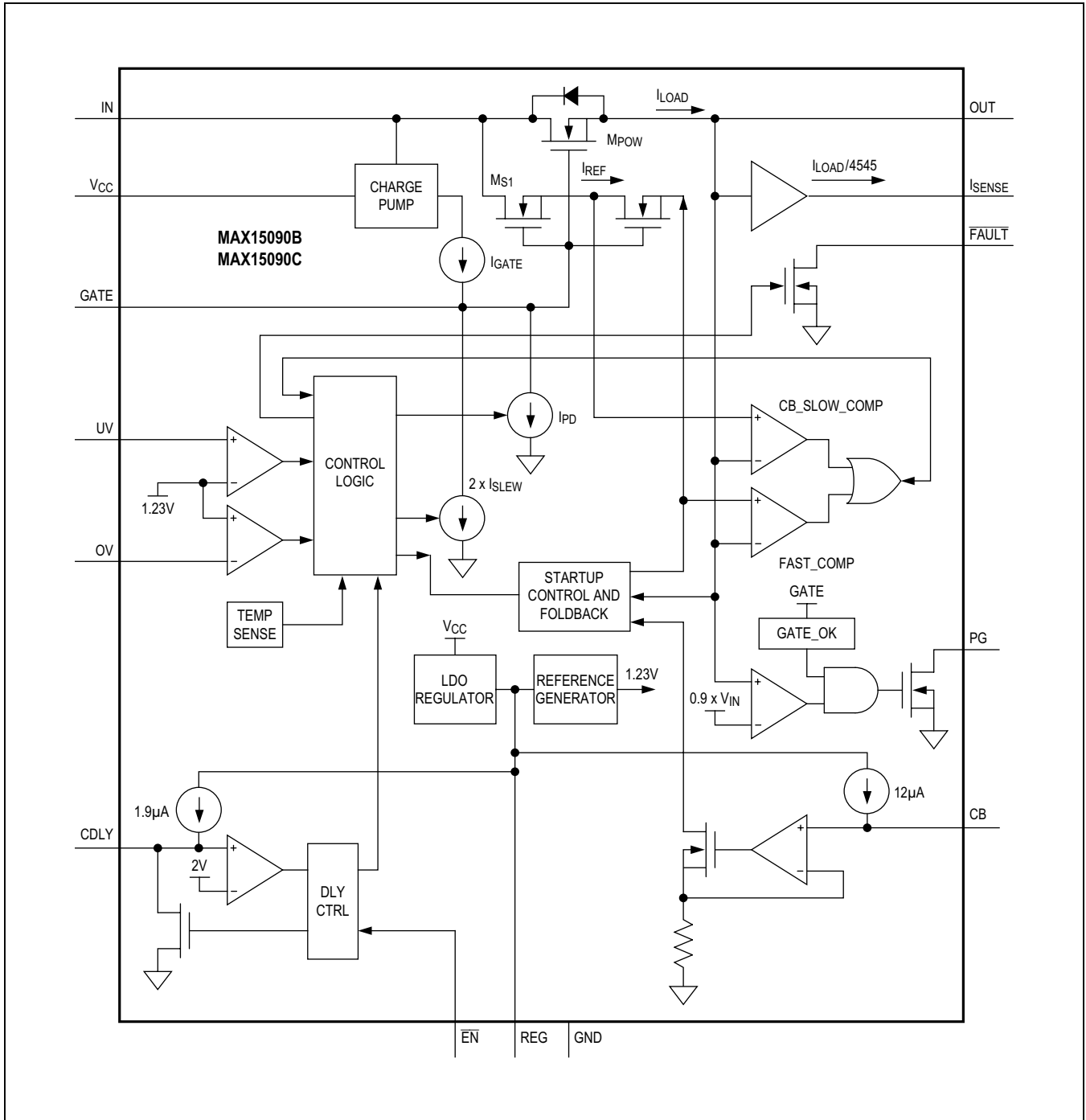

Detailed Description

Enable Logic and Undervoltage/Overvoltage-Lockout Threshold

The MAX15090B/MAX15090C ICs enable the output, as shown in Table 1. The devices are ready to drive the output when the V_{CC} supply rises above the V_{UVLO} threshold. The devices turn on the output when V_{CC} > V_{UVLO}, V_{UV} is high (V_{UV} > 1.23V) and V_{OV} is low (V_{OV} < 1.23V). The devices turn off the output when V_{UV} falls below (1.23V - V_{UV_HYS}) or V_{OV} rises above 1.23V. An external resistive divider from IN to UV, OV, and ground provide the flexibility to set the undervoltage/overvoltage-lockout threshold to any desired level between V_{UVLO} and 18V. See Figure 1 and the [Setting the Undervoltage Threshold](#) and [Setting the Overvoltage Threshold](#) sections.

Startup

Once the device output is enabled, the device provides controlled application of power to the load. The voltage at OUT begins to rise at approximately 10V/ms default until

the programmed circuit-breaker current level is reached, while the devices actively limit the inrush current at the circuit-breaker setting. An external capacitor connected to the GATE pin allows the user to program the slew rate to a value lower than the default. The inrush current can be programmed by selecting the appropriate value of R_{CB}. During startup, a foldback current limit is active to protect the internal MOSFET to operate within the SOA (Figure 2).

An internal 48ms timer (t_{SU}) starts counting when the devices enter the startup phase. The devices complete the startup phase and enter normal operation mode if the voltage at OUT rises above the precharge threshold (0.9 x V_{IN}) and (V_{GATE} - V_{OUT}) > 3V. An open-drain power-good output (PG) goes high-impedance 16ms after the startup successfully completes. Device enters fault mode if startup does not complete before t_{SU} expires. Startup time is nominally V_{OUT} ramp time plus 6ms, including the time it takes for GATE to get to V_{OUT} +3V.

The thermal-protection circuit is always active and the internal MOSFET immediately turned off when the thermal-shutdown threshold condition is reached.

Table 1. Output Enable Truth Table

| POWER SUPPLY V _{CC} | PRECISION ANALOG INPUTS | | OUT |
|-------------------------------------|---|--------------------------------------|-----|
| | UV | OV | |
| V _{CC} > V _{UVLO} | V _{UV} > V _{UV_TH} | V _{OV} < V _{OV_TH} | On |
| V _{CC} < V _{UVLO} | X | X | Off |
| X | V _{UV} < (V _{UV_TH} - V _{UV_HYS}) | X | Off |
| X | X | V _{OV} > V _{OV_TH} | Off |

X = Don't care.
V_{UV_TH} and V_{OV_TH} = 1.23V (typ).

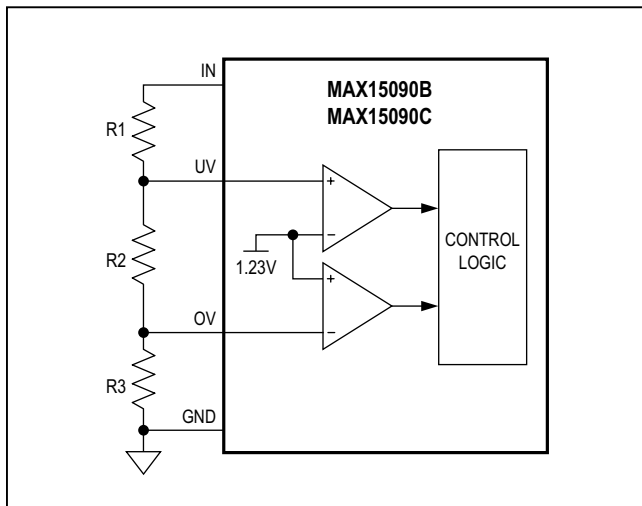

Figure 1. Undervoltage/Overvoltage-Threshold Setting

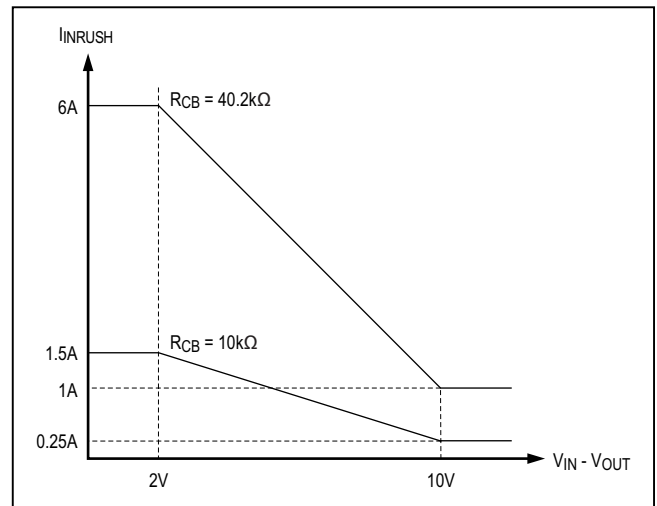

Figure 2. Startup Inrush Current Foldback Characteristics

VariableSpeed/BiLevel Fault Protection

VariableSpeed/BiLevel fault protection incorporates comparators with different thresholds and response times to monitor the load current (see the [Typical Operating Characteristics](#) section). Protection is provided in normal operation (after the startup period has expired) by discharging the MOSFET gate in response to a fault condition. During a fault condition, the MAX15090C enters autoretry mode, while the MAX15090B latches off (see the [Autoretry and Latchoff Fault Management](#) section).

Enable Input ($\overline{\text{EN}}$)

After a startup phase is successfully completed and the power-good output asserted, the $\overline{\text{EN}}$ input has to be pulled low (for at least 1ms) before the t_{DLY} delay elapses. If the $\overline{\text{EN}}$ input is not pulled low before the t_{DLY} elapses, then the devices turn off the internal MOSFET immediately and a new cycle is required for entering power-up mode. Connect a capacitor between CDLY and GND to set a 1s/ μF duration timeout delay. If this function is not implemented, connect $\overline{\text{EN}}$ to GND for proper operation.

Charge Pump

An integrated charge pump provides the gate-drive voltage for the internal power MOSFET. The charge pump generates the proper gate drive voltage above V_{IN} to fully enhance the internal power MOSFET and guarantee low R_{ON} operation during normal state conditions.

During startup, the internal charge pump drives the GATE of the MOSFET with a fixed 5.7 μA current to enhance the internal MOSFET with 10V/ms slew rate (typ). Connect an external capacitor (C_{GATE}) from GATE to GND to reduce the output slew rate during startup. C_{GATE} can be calculated according to the following formula:

$$C_{\text{GATE}} = I_{\text{GATE}} \times (t_{\text{ON}}/V_{\text{OUT}})$$

where I_{GATE} is 5.7 μA (typ), t_{ON} is the desired output ramp-up time, and V_{OUT} is assumed to start from zero.

The slew rate of the OUT pin during startup can be controlled by $I_{\text{GATE}}/C_{\text{GATE}}$ under light-load driving conditions, or by the limited inrush current and the external capacitive load, whichever is less.

$$(\Delta V_{\text{OUT}}/\Delta t) = I_{\text{LIM}}/C_{\text{LOAD}}$$

I_{LIM} varies during startup as V_{OUT} ramps up. See the [Electrical Characteristics](#) table and [Figure 2](#).

Circuit-Breaker Comparator and Current Limit

The current that passes through the internal power MOSFET is compared to a circuit-breaker threshold. An external resistor between CB and GND sets this threshold according to the following formula:

$$I_{\text{CB}} = R_{\text{CB}}/3333.3$$

where I_{CB} is load current in amps and R_{CB} (the resistor between CB and GND) is in ohms.

The circuit-breaker comparator is designed so the load current can exceed the threshold for some amount of time before tripping. The time delay varies inversely with the overdrive above the threshold. The greater the over-current condition, the faster the response time, allowing the devices to tolerate load transients and noise near the circuit-breaker threshold. The maximum allowed external resistor value is 40.2k Ω , which corresponds to a 12A CB threshold setting. Programming the CB threshold to a value higher than 12A could cause unsafe operating conditions, resulting in damage to the devices.

The devices also feature catastrophic short-circuit protection. During normal operation, if OUT is shorted directly to GND, a fast protection circuit forces the gate of the internal MOSFET to discharge quickly and disconnect the output from the input.

Autoretry and Latchoff Fault Management

During a fault condition, the devices turn off the internal MOSFET, disconnecting the output from the input. The MAX15090C enters autoretry mode and restarts after a t_{RESTART} time delay has elapsed. The MAX15090B latches off and remains off until the UV input is cycled off and on after a t_{RESTART} delay. The delay prevents the latchoff device to restart and operate with an unsafe power-dissipation duty cycle.

Fault-Status Output ($\overline{\text{FAULT}}$)

$\overline{\text{FAULT}}$ is an open-drain output that asserts low when the following conditions occur: Current limit, overtemperature, IN-to-OUT short at startup (see the ["IN-to-OUT Short-Circuit Protection"](#) section), and if device does not complete startup before the t_{SU} timer expires (see the [Startup](#) section). $\overline{\text{FAULT}}$ remains low until the next startup cycle. $\overline{\text{FAULT}}$ is capable of sinking up to 5mA current when asserted.

Power-Good (PG) Delay

The devices feature an open-drain, power-good output that asserts after a t_{PG} delay, indicating that the OUT voltage has reached $(0.9 \times V_{IN})$ voltage and $(V_{GATE} - V_{OUT}) > 3V$.

Internal Regulator Output (REG)

The devices include a linear regulator that outputs 3.3V at REG. REG provides power to the internal circuit blocks of the devices and must not be loaded externally (except for a resistor $> 50k\Omega$ connected from REG to \overline{EN}). REG requires at least a $1\mu F$ capacitor to ground for proper operation.

Current Report Output (ISENSE)

The ISENSE pin is the output of an accurate current-sense amplifier and provides a source current that is proportional to the load current flowing into the main switch. The factory-trimmed current ratio is set to $220\mu A/A$. This produces a scaled voltage by connecting a resistor between ISENSE and ground. This voltage signal then goes to an ADC and provides digitized information of the current supplied to the powered system.

Thermal Protection

The devices enter a thermal-shutdown mode in the event of overheating caused by excessive power dissipation or high ambient temperature. When the junction temperature exceeds $T_J = +150^\circ C$ (typ), the internal thermal-protection circuitry turns off the internal power MOSFET. The devices recover from thermal-shutdown mode once the junction temperature drops by $20^\circ C$ (typ).

IN-to-OUT Short-Circuit Protection

At startup, after all the input conditions are satisfied (UV, OV, V_{UVLO}), the devices immediately check for an IN-to-OUT short-circuit fault. If V_{OUT} is greater than 90% of V_{IN} , the internal MOSFET cannot be turned on so \overline{FAULT} is asserted and the MAX15090C enters autoretry mode in 3.2s, while the MAX15090B latches off.

If V_{OUT} is lower than 90% of V_{IN} but greater than 50% of V_{IN} , the internal MOSFET still cannot be turned on. No fault is asserted and the MOSFET can turn on as soon as V_{OUT} is lower than 50% of V_{IN} .

Applications Information

Setting the Undervoltage Threshold

The devices feature an independent on/off control (UV) for the internal MOSFET. The devices operate with a 2.7V to 18V input voltage range and have a default 2.5V (typ) undervoltage-lockout threshold.

The internal MOSFET remains off as long as $V_{CC} < 2.5V$ or $V_{UV} < V_{UV_TH}$. The undervoltage-lockout threshold is programmable using a resistive divider from IN to UV, OV, and GND (Figure 1). When V_{CC} is greater than 2.7V and V_{UV} exceeds the 1.23V (typ) threshold, the internal MOSFET turns on and goes into normal operation. Use the following equation to calculate the resistor values for the desired undervoltage threshold:

$$R1 = \left(\frac{V_{IN}}{V_{UV_TH}} - 1 \right) \times (R2 + R3)$$

where V_{IN} is the desired turn-on voltage for the output and V_{UV_TH} is 1.23V. R1 and (R2 + R3) create a resistive divider from IN to UV. During normal operating conditions, V_{UV} must remain above its 1.23V (typ) threshold. If V_{UV} falls 100mV (V_{UV_HYS}) below the threshold, the internal MOSFET turns off, disconnecting the load from the input.

Setting the Overvoltage Threshold

The devices also feature an independent overvoltage-enable control (OV) for the internal MOSFET.

When V_{OV} exceeds the 1.23V (typ) threshold, the internal MOSFET turns off.

The overvoltage-lockout threshold is programmable using a resistive divider from IN to UV, OV, and GND (Figure 1). Use the following equation to calculate the resistor values for the desired overvoltage threshold:

$$(R1 + R2) = \left(\frac{V_{IN}}{V_{OV_TH}} - 1 \right) \times R3$$

where V_{IN} is the desired turn-off voltage for the output and V_{OV_TH} is 1.23V. R1 and (R2 + R3) create a resistive divider from IN to OV. During normal operating conditions, V_{OV} must remain below its 1.23V (typ) threshold. If V_{OV} rises above the V_{OV_TH} threshold, the internal MOSFET turns off and disconnects the load from the input.

Wafer-Level Packaging (WLP) Applications Information

For the latest application details on WLP construction, dimensions, tape carrier information, PCB techniques, bump-pad layout, recommended reflow temperature profile, as well as the latest information on reliability testing results, refer to Application Note 1891: [Wafer-Level Packaging \(WLP\) and its Applications](#).

Recommended Application Circuit for Hot-Swap Applications

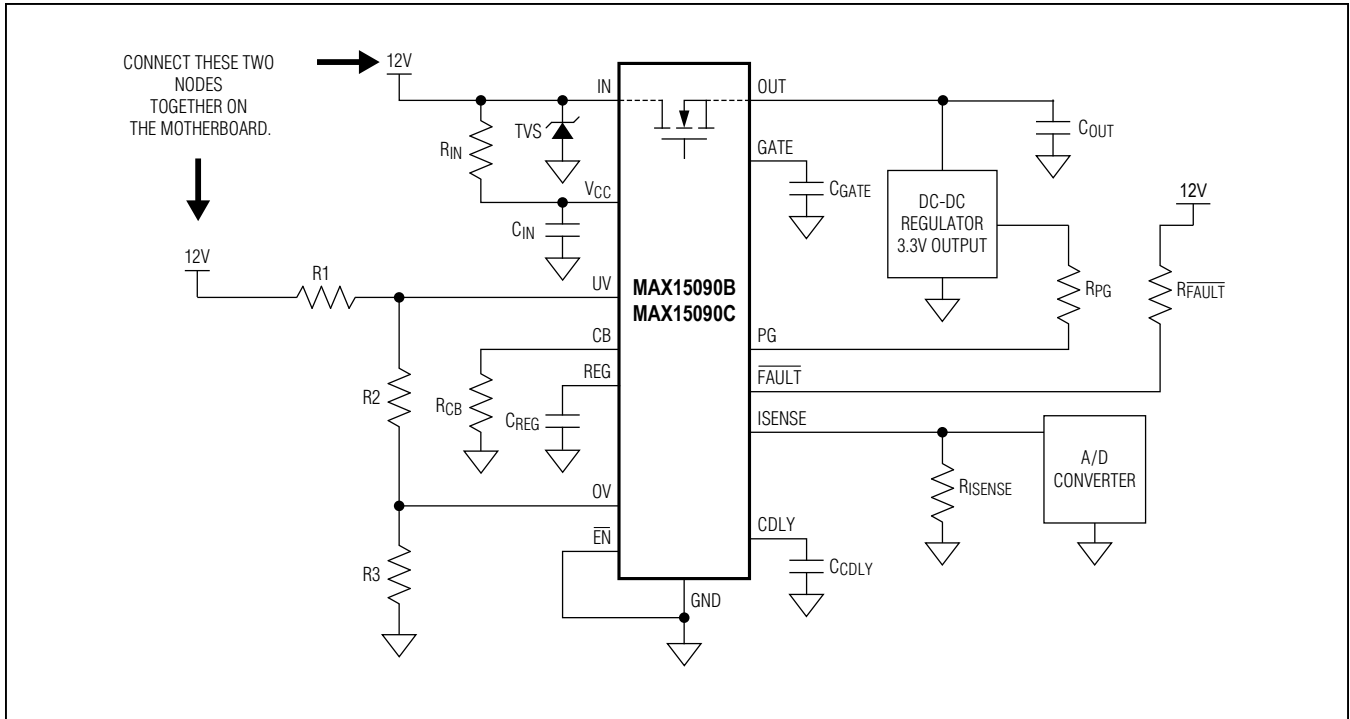

Chip Information

PROCESS: BiCMOS

Ordering Information

| PART | TEMP RANGE | PIN-PACKAGE | FAULT |
|----------------|----------------|-------------|-------------|
| MAX15090BEWI+T | -40°C to +85°C | 28 WLP | Latched Off |
| MAX15090CEWI+T | -40°C to +85°C | 28 WLP | Autoretry |

+Denotes a lead(Pb)-free/RoHS-compliant package.
T = Tape and reel.

Package Information

For the latest package outline information and land patterns (footprints), go to www.maximintegrated.com/packages. Note that a "+", "#", or "-" in the package code indicates RoHS status only. Package drawings may show a different suffix character, but the drawing pertains to the package regardless of RoHS status.

| | PACKAGE CODE | | LAND PATTERN NO. |
|--------|--------------|-------------------------|--|
| 28 WLP | W282B3Z+1 | 21-0577 | Refer to Application note 1891 |

Revision History

| REVISION NUMBER | REVISION DATE | DESCRIPTION | PAGES CHANGED |
|-----------------|---------------|---|-----------------------|
| 0 | 6/15 | Initial release | — |
| 1 | 8/15 | Updated <i>Typical Application Circuit</i> and <i>Recommended Application Circuit for Hot-Swap Applications</i> , <i>Electrical Characteristics</i> table, replaced TOCs 8 and 12 in the <i>Typical Operating Characteristics</i> section, updated Bumps A7 and D1 in the <i>Bump Description</i> table, <i>Startup</i> and <i>Variable Speed/BiLevel Fault Protection</i> sections, and deleted Figure 3 | 1–3, 6, 8, 10, 11, 14 |
| 2 | 5/20 | Updated <i>Electrical Characteristics</i> table | 2–4 |

For pricing, delivery, and ordering information, please contact Maxim Direct at 1-888-629-4642, or visit Maxim Integrated's website at www.maximintegrated.com.

Maxim Integrated cannot assume responsibility for use of any circuitry other than circuitry entirely embodied in a Maxim Integrated product. No circuit patent licenses are implied. Maxim Integrated reserves the right to change the circuitry and specifications without notice at any time. The parametric values (min and max limits) shown in the *Electrical Characteristics* table are guaranteed. Other parametric values quoted in this data sheet are provided for guidance.

Looking for pricing, stock, or lifecycle information?

Click below to explore more details on WIN SOURCE:

- ⊖ [View MAX15090BEWI+T on WIN SOURCE](#)
- ⊖ [Maxim Integrated Information](#)

Optimize Your Supply Chain with WIN SOURCE Solutions

- ✓ Global Sourcing Solution
- ✓ Obsolete Management
- ✓ Cost Control Management
- ✓ Shortage Management
- ✓ Alternative Solution
- ✓ Excess Inventory Management