



**THE DATASHEET OF
TDA38640000AUMA1**



TDA38640 OptiMOS iPOL

40A Single-voltage Synchronous Buck Regulator with SVID and I2C

Quality Requirement Category: Industrial

Features

- Single 5 V to 17 V application or Wide Input Voltage Range from 3.0 V to 17 V with external Vcc
- Output Voltage Range: 0.25 V to 3.04 V with external feedback resistor divider in SVID mode
- Enhanced Fast COT Engine stable with Ceramic output Capacitors and no External Compensation
- Optional Forced Continuous Conduction Mode and Diode Emulation for Enhanced Light Load Efficiency
- Programmable Switching Frequency from 400 kHz to 2 MHz in steps of 200 kHz, excluding 1600 kHz
- Monotonic Startup with Selectable Soft-Start Time via SVID or PMBus Commands & Pre-Bias Startup
- Thermally Compensated Internal Over Current Protection with Eight Selectable Settings
- I2C system interface for reporting of Temperature, Voltage, Current & Power telemetry
- Single Image Multiple Time Programming (MTP) for the USER section
- Digitally programmable load-line without any external components
- 12 V input current sensing is supported without the need of an external interface circuit
- Operating temp: $-40\text{ }^{\circ}\text{C} < T_j < 125\text{ }^{\circ}\text{C}$
- Small Size: 5 mm x 6 mm PQFN
- Lead-free, Halogen-free and RoHS2 Compliant with Exemption 7a

Applications

- Server Applications
- Storage Applications
- Telecom & Datacom Applications
- Distributed Point of Load Power Architectures

Description

The TDA38640 is an easy-to-use, fully integrated and highly efficient dc-dc regulator with Intel SVID and I2C/PMBUs interfaces. The controller utilizes Infineon's fast COT engine which simplifies the design efforts, and achieves faster transient response.

The onboard PWM controller and OptiMOS™ FETs with integrated bootstrap diode make TDA38640 a small footprint solution, providing high-efficiency power delivery for low voltage high current applications which may need an SVID interface.

TDA38640 is a versatile regulator, operating with wide input and output voltage range, offering eight programmable switching frequency from 400 kHz to 2 MHz excluding 1600 kHz, and providing eight unique selectable current limits via the PMBUs commands.

It also features important protection functions, like the thermally compensated current limit, over voltage and under voltage protection, and thermal shutdown to give required system level security in the event of fault conditions. The part supports programmable digital dc loadline, providing the customer with an additional tool

to manage the transients for a given rail. The device supports 12 V differential input current sensing (through the pins VINSEN_P and VINSEN_M) without the need of external interface circuitry (e.g. pi-sense, etc.) which simplifies the design, reduces complexity, and results in reported current being more consistent and accurate, as it only depends on the internal IC circuitry where the parameters are trimmed for every part to meet specifications.

The device configuration can be easily defined using Infineon's XDP Designer GUI and is stored in the on-chip memory. The TDA38640 provides extensive OVP, UVP, OCP, OTP & Boot UVLO fault protection. The controller requires the fewest possible external components and results in a simplified Bill of Materials (BOM).

Table of Contents

1	Ordering Information	5
2	Functional Block Diagram	6
3	Typical Application Diagram	7
4	Pin Descriptions.....	8
5	Absolute Maximum Ratings.....	10
6	Thermal Characteristics	12
7	Electrical Specifications	13
7.1	Electrical Characteristics.....	14
8	Typical Efficiency and Power Loss Curves	19
8.1	$PV_{in} = 12\text{ V}$, $F_{sw} = \text{Varying}$	19
8.2	$PV_{in} = 12\text{ V}$, $F_{sw} = 800\text{ kHz}$	20
8.3	$PV_{in} = \text{Varying}$, $F_{sw} = 1000\text{ kHz}$	20
9	Thermal De-rating curves	22
10	RDS(on) of MOSFET Over Temperature	23
11	Typical operating characteristics ($-40\text{ }^{\circ}\text{C} \leq T_j \leq +125\text{ }^{\circ}\text{C}$)	24
12	General Description	26
12.1	Intel Operating Mode	26
12.2	PMBUS Operating Mode.....	26
12.3	Multiple Time Programming Memory.....	26
12.4	Voltage Sense	27
12.5	VID Decoder	27
12.6	I2C & PMBus Interface	27
12.7	Infineon XDP Designer GUI.....	27
12.8	Programming.....	29
12.9	Real-time Monitoring	29
13	Theory of Operation	30
13.1	Operating Mode.....	30
13.2	Device Power-On.....	30
13.3	Pre-bias startup.....	31
13.4	Internal Low-Dropout (LDO) Regulator	31
13.5	Fast Constant ON-Time Control.....	31
13.6	Enable (EN) Pin.....	31
13.7	Switching Frequency and FCCM/DEM Operation.....	32
13.8	Intel Mode.....	32
13.8.1	Intel Boot Mode.....	33
13.8.2	Intel SVID Interface.....	33
13.8.3	All Call SUPPORT	33
13.8.4	VR13 Operation	33
13.8.5	VR14 Operation	33
13.8.6	Set Work Point.....	34
13.9	Program Pin (SM_ADDR/PROG)	36
13.10	Soft Start.....	37
13.11	Load-line.....	37
13.12	Output Voltage Differential Sensing.....	37
13.13	Input Current Sensing	38
13.14	CAT_FAULT# and VRRDY	39
14	Faults and Protection	40

14.1	Over Current Protection (OCP)	40
14.2	Output Under Voltage Protection (UVP)	41
14.3	Over Voltage Protection (OVP)	42
14.4	Over Temperature Protection (OTP)	43
14.5	Boot Under Voltage Lockout (UVLO)	43
14.6	Minimum On - Time and Minimum Off - Time	43
14.7	High-Side Short (HSS) Detection	44
15	Fault Communication	45
15.1	I2C Slave Addressing	45
15.2	Real-Time Telemetry	45
15.3	I2C Protocol	45
15.4	PMBus Commands Supported	46
15.5	11-BIT Linear Data Format	51
15.6	16-BIT Linear Data Format	51
15.7	SVID Registers	52
16	Design example	57
16.1	Enabling the TDA38640	57
16.2	Programming the Switching Frequency and Operation Mode	57
16.3	Selecting Input Capacitors	57
16.4	Inductor Selection	58
16.5	Output Capacitor Selection	58
16.6	Output Voltage Programming	59
16.7	Bootstrap Capacitor	59
16.8	PVIN, and VCC/LDO bypass Capacitor	59
16.9	Design Recommendations	59
17	Layout Recommendations	60
17.1	PCB Metal and Component Placement	60
17.2	Solder Resist	61
17.3	Stencil Design	62
18	Package	64
18.1	Marking Information	64
18.2	Dimensions	64
18.3	Tape and Reel Information	67
19	Environmental Qualifications	68
20	Revision history	69

Ordering Information

1 Ordering Information

Table 1 Ordering Information

Base Part Number	Package Type	Standard Pack Form and Qty		Orderable Part Number
TDA38640	QFN 5 mm x 6 mm	Tape and Reel	5000	TDA38640aabbAUMA1

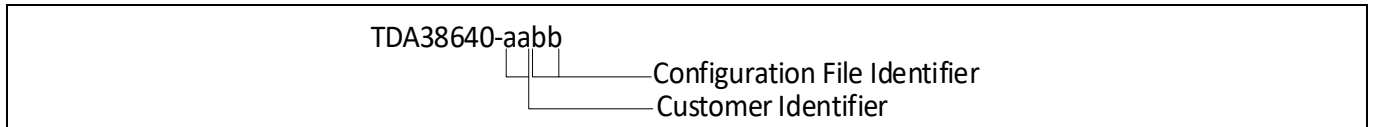

Figure 1 Orderable Part Number Description

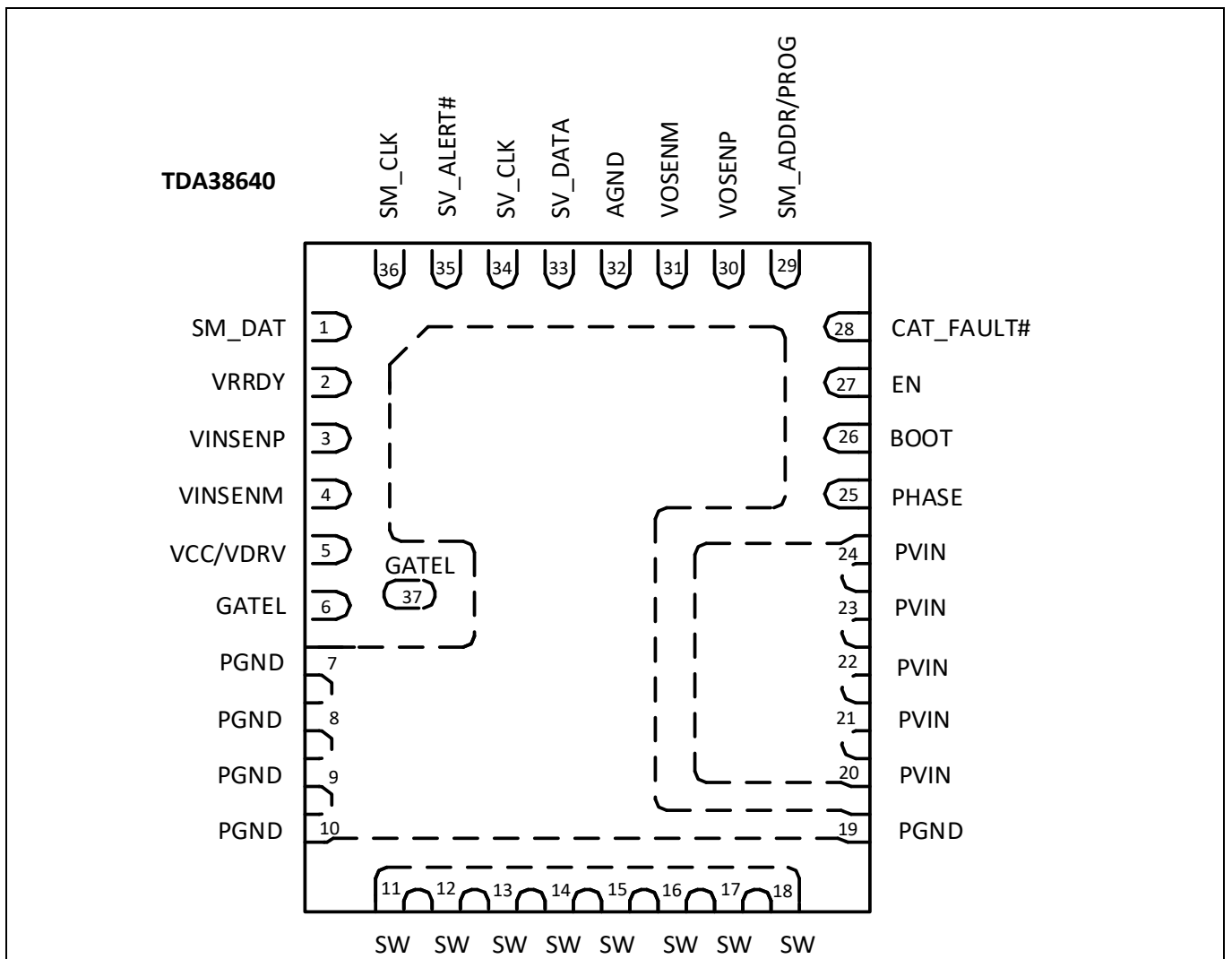

Figure 2 Package Top View

2 Functional Block Diagram

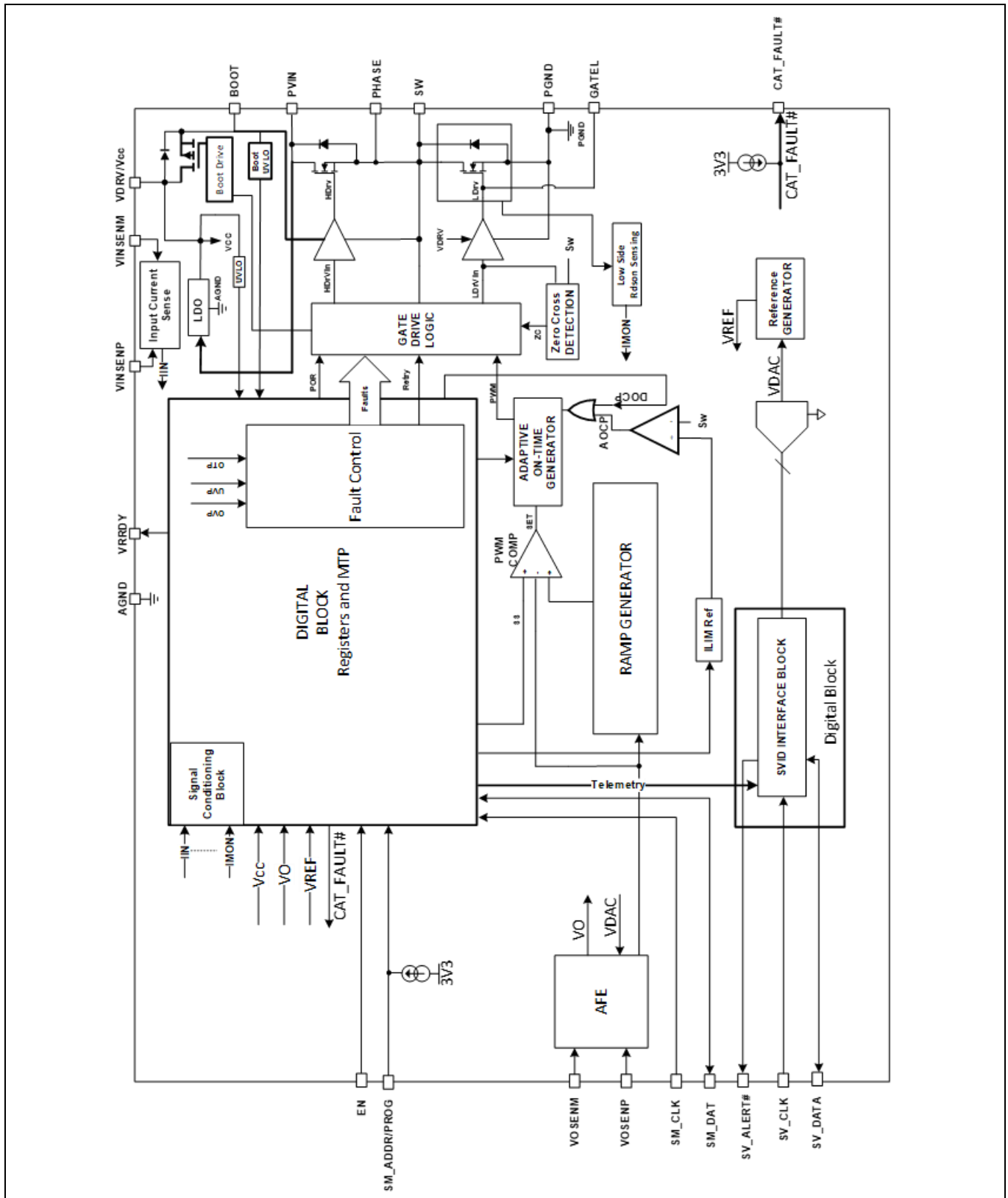

Figure 3 Block Diagram

Pin Descriptions

4 Pin Descriptions

Table 2 Pin Descriptions

Note:

1. A - Analog; D - Digital; [I]- INPUT; [O]- OUTPUT; [B]- BI-DIRECTIONAL; [P]- POWER
2. Refer to Section 13.9 for more details

Pin#	Pin Name	Pin Type	Pin Description
1	SM_DAT	D [B]	I2C bi-directional serial data line. Ground it if not used.
2	VRRDY	D [O]	Open-drain output that asserts high when the VR has completed soft-start to boot. Pull-up to an external voltage through a resistor.
3	VINSEN P	A [I]	This pin connects to the positive side of the shunt resistor that is used to monitor the input current. Connect to PVIN if not used.
4	VINSEN M	A [I]	This pin connects to the negative side of the shunt resistor that is used to monitor the input current. Connect to PVIN if not used.
5	Vcc/Vdrv	A [P]	Input bias for the external Vcc voltage and internal driver/output of the internal LDO. A 2.2 uF ceramic capacitor is recommended to use between Vcc and the analog ground (AGND). Connect to external Supply when internal LDO is not used.
6, 37	GATEL	A [O]	Gate of Low-side FET. The signal on this pin should be used for test purposes only and should not have external components connected to it. Leave it open if not used.
7, 8, 9, 10, 19	PGND	-	Power Ground. Should be connected to the system's power ground plane. PGND and AGND are internally connected via the lead frame.
11, 12, 13, 14, 15, 16, 17, 18	SW	A [O]	Switch Node. Connect these pins to an output inductor.
20, 21, 22, 23, 24	PVin	A [P]	Input supply for the power stage.
25	Phase	A [O]	Source of High-side FET. Connect a bootstrap capacitor between this pin and Boot pin. A high temperature (x7R) 0.1 uF or greater value ceramic capacitor is recommended.
26	Boot	A [I]	Supply voltage for the high side driver. Connect this pin to the Phase pin of the regulator through a bootstrap capacitor. For PVin above 14 V, a resistor is recommended in series with the bootstrap capacitor to control the slew rate of the SW node rising edge.
27	EN	A [I]	Enable pin to turn on and off the IC. Leave it open or ground it when not used.
28	CAT_FAULT#	D [O]	This is an Active Low open drain output that asserts when a catastrophic fault is detected. Leave it open when not used.
29	SM_ADDR/PROG	D [I]	I2C Slave Address. A resistor to ground on this pin; points to one of the unique 16 I2C slave devices ² which needs to be addressed on the board, it does it by adding a fixed offset to

Pin Descriptions

Pin#	Pin Name	Pin Type	Pin Description
			the I2C base address. The same resistor also defines the specific configuration file that will be loaded from the OTP during power-up.
30	VOSENP	A [I]	Direct sense output line connected after the switch node inductor.
31	VOSENM	A [I]	This pin provides the return connection for remote output voltage sensing. It is used as the internal reference voltage by the Analog Front End (AFE).
32	AGND	-	Signal ground for the internal circuitry. Connect it to the PGND power plane.
33	SV_DATA	D [B]	Serial VID Data I/O. This is a bi-directional serial line over which the CPU Master issues commands and receives data back. Leave the pin open or Ground it if not being used.
34	SV_CLK	D [I]	Serial VID Clock Input. Clock input driven by the CPU Master. Leave the pin open or Ground it if not being used.
35	SV_ALERT#	D [O]	Serial VID ALERT# (INTEL). SV ALERT# is pulled low by the controller to alert the CPU of VR 14/13/12/12.5 status. Leave the pin open if not being used.
36	SM_CLK	D [I]	Serial Clock Line Input. I2C clock input. The interface is rated to 1 MHz. Ground the pin if not being used.

Absolute Maximum Ratings

5 Absolute Maximum Ratings

Stresses higher than those mentioned in Table 3 below may result in permanent damage to the device. These are the absolute stress ratings only and the operation of the device is not recommended or implied at these or any other condition's in excess of those given in the recommended operating ratings in Table 5. Exposure of values over and above the recommended ratings for extended periods may adversely affect the operation and reliability of the device.

Table 3 Absolute Maximum Ratings

Description	Symbol	Values			Unit	Note/ Test Conditions
		Min	Typ	Max		
Power Input Voltage	V_{PVIN}	-0.3	-	25	V	Note 3, PVIN Pin
Positive Input-Current-Sense voltage	$V_{VINSEN P}$	-0.3	-	25	V	Note 3, VINSEN P Pin
Enable voltage	V_{EN}	-0.3	-	25	V	EN Pin
PVIN-PHASE voltage	$V_{PVIN} - V_{PHASE}$	-5 V for 5 ns, -0.3 V dc	-	34 V for 1 ns, 25 V dc	V	PVIN-PHASE pin
PVIN-Switch Node voltage	$V_{PVIN} - V_{SW}$	-5 V for 5 ns, -0.3 V dc	-	34 V for 1 ns, 25 V dc	V	PVIN- SW Pin
Internal Driver Voltage	V_{DRV}	-0.3	-	6	V	Note 3, VCC/VDRV Pin
Gate Low Pin Voltage	V_{GATEL}	-0.3	-	6	V	GateL Pin
BOOT Voltage	V_{BOOT}	-0.3 V for 5 ns, -0.3 V dc	-	29 V dc	V	BOOT Pin
	$V_{BOOT} - V_{PHASE}$	-0.3	-	7 V for 5 ns, 6 V dc	V	BOOT – PHASE Pin
Switch Node voltage	V_{SW}	-5 V for 5 ns, -0.3 V dc	-	34 V for 1 ns, 25 V dc	V	Switch Node Pin
Phase Node voltage	V_{PHASE}	-5 V for 5 ns, -0.3 V dc	-	34 V for 1 ns, 25 V dc	V	Phase Pin
Address/PROG voltage	$V_{SM_ADDR/PROG}$	-0.3	-	3.6	V	Note 3, SM_ADDR/PROG Pin
Output Positive Sense voltage	$V_{VOSEN P}$	-1.5 V for 5 ns, -0.3 dc	-	3.6	V	Note 3, VOSEN P Pin
Output Negative Sense voltage w.r.t AGND	$V_{VOSEN M}$	-0.3	-	0.3	V	Note 3, VOSEN M Pin
Voltage Regulator Ready voltage	V_{VRRDY}	-0.3	-	3.6	V	Note 3, VRRDY Pin
Power GND w.r.t Analog GND voltage	$V_{PGND} - V_{AGND}$	-1.5 V for 5 ns, -0.3 dc	-	1.5 V for 5 ns, 0.3 dc	V	PGND – AGND Pin
SVID CLK voltage	V_{SV_CLK}	-0.3	-	3.6	V	SV_CLK Pin
SVID Data voltage	V_{SV_DAT}	-0.3	-	3.6	V	SV_DAT Pin
SVID Alert voltage	$V_{SV_ALERT\#}$	-0.3	-	3.6	V	SV_ALERT# Pin
SM CLK voltage	V_{SM_CLK}	-0.3	-	3.6	V	SM_CLK Pin
SM Data voltage	V_{SM_DAT}	-0.3	-	3.6	V	SM_DAT Pin

Absolute Maximum Ratings

Description	Symbol	Values			Unit	Note/ Test Conditions
		Min	Typ	Max		
Catastrophic Fault voltage	V _{CAT_FAULT#}	-0.3	-	3.6	V	CAT_FAULT# Pin
Junction Temperature	T _{Jmax}	-40	-	150	°C	-
Storage Temperature	T _{STORAGE}	-55	-	150	°C	-

Note:

3. PGND and AGND pins are connected together

Attention: Stresses beyond these listed under “Absolute Maximum Ratings” may cause permanent damage to the device. These are stress ratings only and functional operation of the device at these or any other conditions beyond those indicated in the operational sections of the specifications are not implied.

6 Thermal Characteristics

Table 4 Thermal Characteristics

Description	Symbol	Values	Test Conditions
Junction to Ambient Thermal Resistance	θ_{JA}	19 °C/W	Note 4
Junction to PCB Thermal Resistance	θ_{JC-PCB}	1.1 °C/W	Note 5
Junction to Case Top Thermal Resistance	θ_{JC}	24 °C/W	

Note:

4. Thermal resistance is measured with components mounted on a standard EVAL_TDA38640_1Vout demo board in free air
5. Thermal resistance is based on the board temperature near pin 22

7 Electrical Specifications

Table 5 Recommended Operating Conditions for Reliable Operation

Description	Min	Max	Unit	Note
PVin Voltage Range with External Vcc	3	17	V	Note 6, Note 7
PVin Voltage Range with Internal LDO	5	17	V	Note 7, Note 8 & Note 11
Vcc Supply Voltage Range	4.5	5.5	V	Note 6, Note 9
Output Voltage Range	0.25	3.04	V	Note 10
Continuous Output Current Range		40	A	Note 11
Switching Frequency (excluding 1600 kHz)	400	2000	kHz	Note 12
Operating Junction Temperature	-40	125	°C	

Note:

6. VCC/VDRV pin is connected to an external bias voltage for PVIN less than 5 V
7. A common practice is to have 20% margin on the maximum SW node voltage in the design. For applications requiring PVin equal to or above 14 V, a small resistor in series with the Boot pin should be used to ensure the maximum SW node spike voltage not exceeding absolute maximum dc and ac specs. Alternatively, a snubber can be used at SW node to reduce the SW node spike.
8. PV_{in} with internal LDO is used. For single-rail applications with the internal LDO and PV_{in} = 5 V-6 V, the internal LDO may enter dropout mode. AOCPLimits can be reduced due to the lower VCC voltage.
9. The TDA38640 is designed to function with VCC down to 4.5 V, however, electrical specifications such as AOCPLimits may be degraded.
10. The maximum output voltage is limited by the minimum off-time. For output voltages above 2.56 V, an external feedback resistor divider is needed. The limitation of 3.04 V is valid only in SVID mode, for PMBus mode this goes up to 5.12 V.
11. Refer to Section 14.1 for maximum output current rating at different ambient temperatures and OCP threshold tolerance.
12. The maximum LDO output current must be limited within 60 mA for operations requiring full operating temperature range of $-40\text{ °C} \leq T_J \leq 125\text{ °C}$. Thermal De-rating may be needed at an elevated ambient temperature to ensure the junction temperature within the recommended operating range.

Electrical Specifications

7.1 Electrical Characteristics

Unless otherwise specified, these specifications apply over, $5\text{ V} \leq \text{PVin} \leq 17\text{ V}$, in $0\text{ }^\circ\text{C} < \text{T}_\text{J} < 125\text{ }^\circ\text{C}$.

Typical values are specified at $\text{T}_\text{a} = 25\text{ }^\circ\text{C}$.

Table 6 Electrical Characteristics

Parameter	Symbol	Conditions	Min	Typ	Max	Unit
Power Stage						
Top Switch	$R_{\text{ds(on)_Top}}$	$V_{\text{Boot}} - V_{\text{sw}} = 5.0\text{ V}$, $I_{\text{O}} = 35\text{ A}$, $\text{T}_\text{j} = 25\text{ }^\circ\text{C}$	-	2.9	-	m Ω
Bottom Switch	$R_{\text{ds(on)_Bot}}$	$V_{\text{cc}} = 5.0\text{ V}$, $I_{\text{O}} = 35\text{ A}$, $\text{T}_\text{j} = 25\text{ }^\circ\text{C}$	-	1.0	-	
Bootstrap Diode Forward Voltage		$I(\text{Boot}) = 25\text{ mA}$	-	780	950	mV
SW Leakage Current	I_{sw}	$\text{SW} = 0\text{ V}$, $\text{EN} = 0\text{ V}$	-	-	175	μA
		$\text{SW} = 0\text{ V}$, $\text{EN} = \text{high}$, No Switching	-	-	175	
Dead Band Time	T_{db}	SW Node rising edge, 40 A, Internal LDO, $\text{T}_\text{j} = 25\text{ }^\circ\text{C}$, Note 13	-	10	-	ns
		SW Node falling edge, 40 A, Internal LDO, $\text{T}_\text{j} = 25\text{ }^\circ\text{C}$, Note 13	-	10	-	
Supply Voltage						
PVin and External Vcc						
PVin range (using external VCC = 5V)			-	3 - 17	-	V
External Vcc Range			4.5	5	5.5	V
Supply Current						
Iin						
PVin Supply Current (standby, LDO)	$I_{\text{in(Standby)}}$	$\text{EN} = \text{Low}$, No Switching	-	12	-	mA
PVin Supply Current (dynamic, LDO)	$I_{\text{in(Dyn)}}$	$\text{EN} = \text{High}$, $F_{\text{sw}} = 800\text{ kHz}$, $\text{PVIN} = 12\text{ V}$, $V_{\text{out}} = 1.1\text{ V}$, Note 13	-	48	-	mA
Digital Inputs						
VR_ENx (Intel)						
Input High Voltage			0.70	-	-	V
Input Low Voltage			-	-	0.50	V
Input Impedance			-	1	-	M Ω
Digital Inputs						
SV_CLK, SV_DAT						
Input High Voltage			0.65	-	-	V
Input Low Voltage			-	-	0.45	V
Hysteresis			-	95	-	mV
Input Leakage Current		$\text{SV_CLK} = 3.6\text{ V}$	-1	-	1	μA
Pin Capacitance		See Note 13	-	-	4	pF
Digital Inputs - LVTTTL						
SM_DAT, SM_CLK						
Input High Voltage			2.31	-	-	V
Input Low Voltage			-	-	0.99	V

TDA38640 OptiMOS iPOL

40A Single-voltage Synchronous Buck Regulator with SVID and I2C



Electrical Specifications

Parameter	Symbol	Conditions	Min	Typ	Max	Unit
Input Leakage Current		SM_CLK = 3.6 V	-1	-	1	μA
Pin Capacitance		See Note 13	-	-	4	pF
Remote Voltage Sense Inputs	VOSENP, VOSENM					
VOSENP Input Current		VOSENP = 3.6 V	-	-	230	μA
		VOSENP = -0.3 V	-85	-	-	μA
VOSENM Input Current		VOSENM = 0.3 V	-155	-	-	μA
		VOSENM = -0.3 V	-200	-	-	μA
Differential Input Voltage Range			-	-	2.56	V
VOSENM Input CM Voltage			-	±300	-	mV
Input Current Sense Input	VINSENP, VINSENM					
VINSENP Input current			-	200	-	μA
VINSEM Input Current			-	-	5	μA
Analog Address/Level Inputs	SM_ADDR/PROG					
Output Current			-	15	-	μA
Open-Drain Outputs-20mA Drive	VRRDYx, CAT_FAULT#					
Output Low Voltage		I = 20 mA	-	-	0.3	V
Output Leakage		V _{VRRDY} = 3.6 V	-5	-	5	μA
Open-Drain Outputs-20mA Drive	SV_DAT, SV_ALERT#, SM_DAT					
Output Low Voltage		I = 20 mA	-	-	0.26	V
On Resistance		I = 20 mA	4	-	13	Ω
Tri-State Leakage			-5	-	5	μA
On-Time Timer						
Frequency Range (programmable)		Excluding 1600 kHz and in steps of 200 kHz	400	--	2000	kHz
Minimum On-Time		T _j =25 °C, Note 13, PVIN = 12 V, V _o = 0 V, See Note 15	-	25	-	ns
Minimum Off-Time	Toff (Min)	T _j =25 °C, VFB=0 V, See Note 13	-	150	-	ns
System Set Point Accuracy (5 mV and 10 mV step mode voltage)						
VBOOT Voltage Range			Meets Spec			V
0.25 V ≤ VID ≤ 0.795 V		-40 °C ≤ T _j ≤ 125 °C	-	±10	-	mV
0.8 V ≤ VID ≤ 0.995 V		VDD > VID + 200 mV	-	±8	-	mV
1.0 V ≤ VID ≤ 2.52 V		Typ = 3σ, Note 13 & 14	-	±1	-	%VID
VCC LDO Output	Vcc					
Vcc Output Voltage	Vcc	5.5 V ≤ PVIN ≤ 17 V, when I _{cc} = 50 mA, C _{load} = 2.2 μF, T _j = 25 °C	4.7	5.0	5.3	V

Electrical Specifications

Parameter	Symbol	Conditions	Min	Typ	Max	Unit
VCC Dropout	Vcc_drop	PVIN = 4.5 V, Icc = 50 mA, Cload = 2.2 uF, Tj = 25 °C	-	650	-	mV
Under Voltage Lockout						
Vcc_Good Start Threshold	VCC_UVLO_Start	Vcc Rising Trip Level	3.8	-	4.2	V
Vcc_Good Stop Threshold	VCC_UVLO_Stop	Vcc Falling Trip Level	3.6	-	4.0	
Enable-Start-Threshold	Enable_UVLO_Start	ramping up	0.61	0.65	0.69	V
Enable-Stop-Threshold	Enable_UVLO_Stop	ramping down	0.51	0.55	0.59	
Boot Rising Threshold	BOOT_UVLO_Rising	Boot-Phase Ramping up, Note 13	3.7	3.85	4.0	V
Boot Falling Threshold	BOOT_UVLO_Falling	Boot-Phase Ramping down, Note 13	3.5	3.65	3.8	V
IMON Reporting Accuracy						
IMON Accuracy TDA38640 (40 A)	Imon	Maximum load	-	±6	-	%
Over Current Limit						
Current Limit Threshold (Valley Current)	I _{oc}	Tj = 25 °C, Vcc = 5.0V	-	10	-	A
			-	15	-	
			-	20	-	
			-	25	-	
			-	30	-	
			-	40	-	
			-	50	-	
Current Limit Threshold Accuracy		See Note 13	-	± 20	-	%
Over Voltage Protection						
Output Fixed OVP Threshold (Programmable)	OVP_Vth	VID Rising	-	0.8	-	V
			-	1.0	-	
			-	1.2	-	
			-	1.35	-	
			-	1.5	-	
			-	1.8	-	
			-	2.2	-	
Output Fixed OVP Threshold Accuracy		See Note 13	-	±5	-	%
Output Relative OVP Threshold (programmable)		Relative to VID in steps of 50 mV in VOUT_SCALE_LOOP 1:1 mode	50	-	400	mV
Output Relative OVP Threshold Accuracy		Relative to VID in steps in VOUT_SCALE_LOOP 1:1 mode	-	± 100	-	mV
Under Voltage Protection						

Electrical Specifications

Parameter	Symbol	Conditions	Min	Typ	Max	Unit
Output Relative UVP Threshold (programmable)	UVP_Vth	Relative to VID in steps of 50 mV in VOUT_SCALE_LOOP 1:1 mode	50	-	400	mV
Output Relative UVP Threshold Accuracy		Relative to VID in steps; in VOUT_SCALE_LOOP 1:1 mode	-	± 100	-	mV
I2C and Reporting						
Bus Speed		Normal	-	100	-	kHz
		Fast	-	400	-	kHz
		High-Speed	-	1000	-	kHz
Output Voltage Resolution		Note 15 and 16	-	0.625, 0.977, 1.953, 3.906	-	mV
Output Voltage Filter Rate			-	8	-	kHz
Output Voltage Update Rate			-	379	-	kHz
Highest Reported Vout		VOUT_SCALE_LOOP=1:1	-	-	2.56	V
Vout Reporting Accuracy		-40 °C - 125 °C (Tj), 4.5 V < Vcc < 5.5 V, 0.25 ≤ VID ≤ 0.5; VOUT_SCALE_LOOP in 1:1 mode	-2	-	2	%
		-40 °C - 125 °C (Tj), 4.5 V < Vcc < 5.5 V, 0.5 < VID ≤ 2.52; VOUT_SCALE_LOOP in 1:1 mode	-1	-	1	%
Iout Resolution			-	0.0625	-	A
Iout Filter Rate			-	8	-	kHz
Iout Update Rate			-	379	-	kHz
Iout Digital Monitoring Range			-		64	A
Iout Reporting Accuracy (PMBus)		0 °C-125 °C, 4.5V<Vcc<5.5V 0 A ≤ Iout ≤ 40 A 0.25 V ≤ Vout ≤ 2.52 V, Note 15	-	±6	-	%
Temperature Resolution			-	1	-	°C
Temperature Filter Rate			-	4	-	kHz
Temperature Update Rate			-	189	-	kHz
Temperature Monitoring Range			-40	-	125	°C
Temperature Reporting Accuracy		See Note 13	-	±1	-	°C

Electrical Specifications

Parameter	Symbol	Conditions	Min	Typ	Max	Unit
Thermal Shutdown		See Note 13	-	140	-	°C
Thermal Shutdown Hysteresis		See Note 13	-	20	-	°C
Input Power Resolution			-	0.5	-	W
Input Power Reporting Range			-	-	1024	W
Input Power Filter Rate			-	8	-	kHz
Input Power Update Rate			-	379	-	kHz
Input Power Accuracy		A 4-terminal 1 mΩ (1 % accurate) shunt is used, Note 15	-	±3	-	%

Note:

13. *Guaranteed by design and not tested in production*
14. *Cold temperature performance is guaranteed via correlation using statistical quality control. Not tested in production.*
15. *Guaranteed by Bench Characterization at Room Temperature and not tested in production*
16. *Actual output is limited by the resolution of the internal DAC*

8 Typical Efficiency and Power Loss Curves

8.1 $P_{Vin} = 12\text{ V}$, $F_{sw} = \text{Varying}$

The test for efficiency was done at 0 LFM and the driver losses are included in the efficiency numbers. Solid line indicate efficiency and dashed lines are showing power loss.

Table 7 Inductors for $P_{Vin}=12\text{ V}$, $F_s = \text{varying}$

Vout (V)	Lout (nH)	P/N	Frequency(kHz)	DCR (mΩ)	Inductor Size (mm ³)
1.1 (Ext. Vcc)	100	L101247A-100L	600	0.125	10 x 6.4 x 12
			800		
			1000		

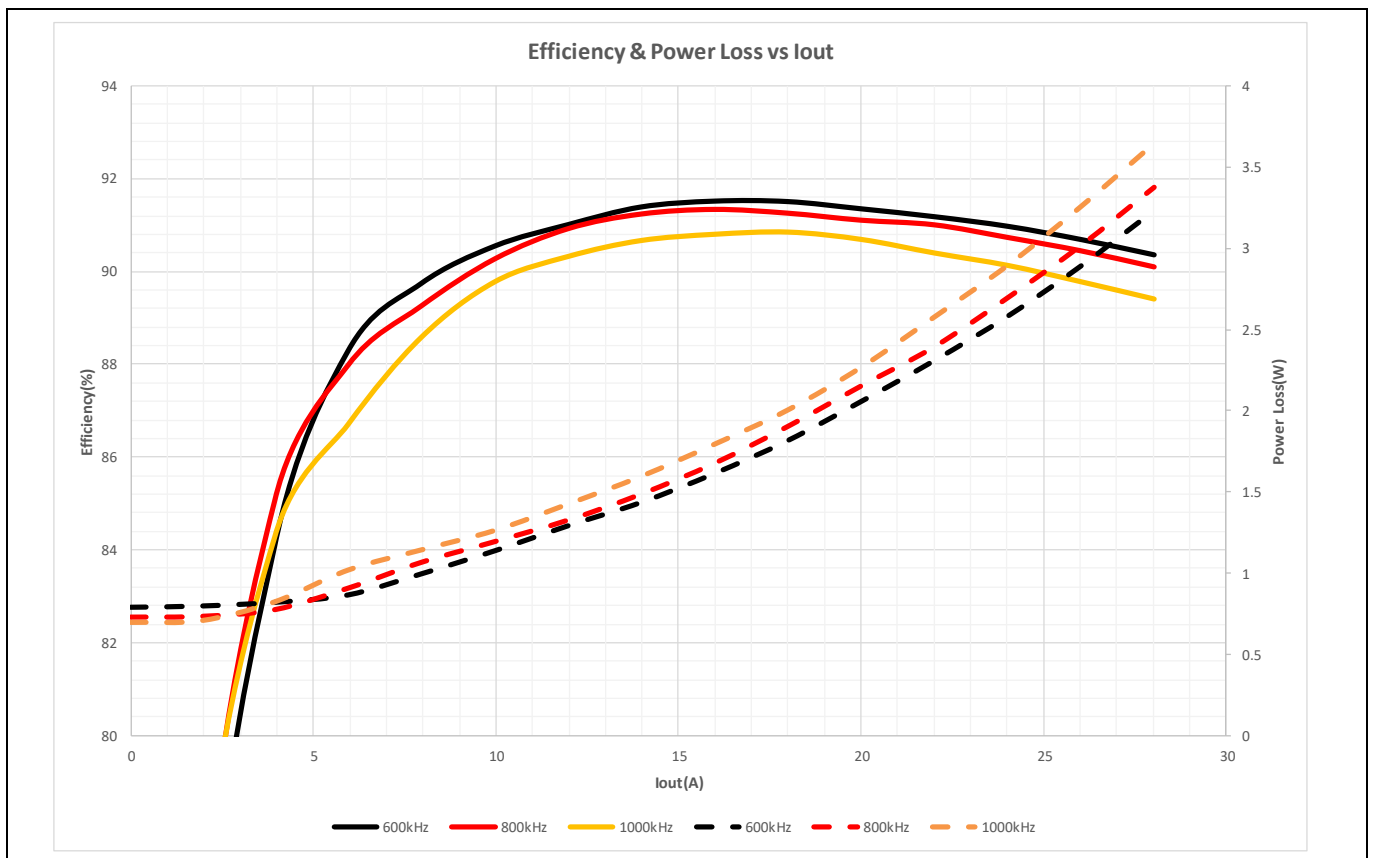

Figure 6 Typical efficiency and power loss curves, $P_{Vin} = 12\text{ V}$, $F_{sw} = \text{Varying}$

Typical Efficiency and Power Loss Curves

8.2 $P_{V_{in}} = 12\text{ V}$, $F_{sw} = 800\text{ kHz}$

The test for efficiency was done at 0 LFM and the driver losses are included in the efficiency numbers. Solid line indicate efficiency and dashed lines are showing power loss.

Table 8 Inductors for $P_{Vin}=12\text{ V}$, $F_{sw} = 800\text{ kHz}$

Vout (V)	Lout (nH)	P/N	Frequency(kHz)	DCR (mΩ)	Inductor Size (mm ³)
1.1 (Ext. Vcc)	100	L101247A-100L	800	0.125	10 x 6.4 x 12
1.1 (Int. Vcc)					

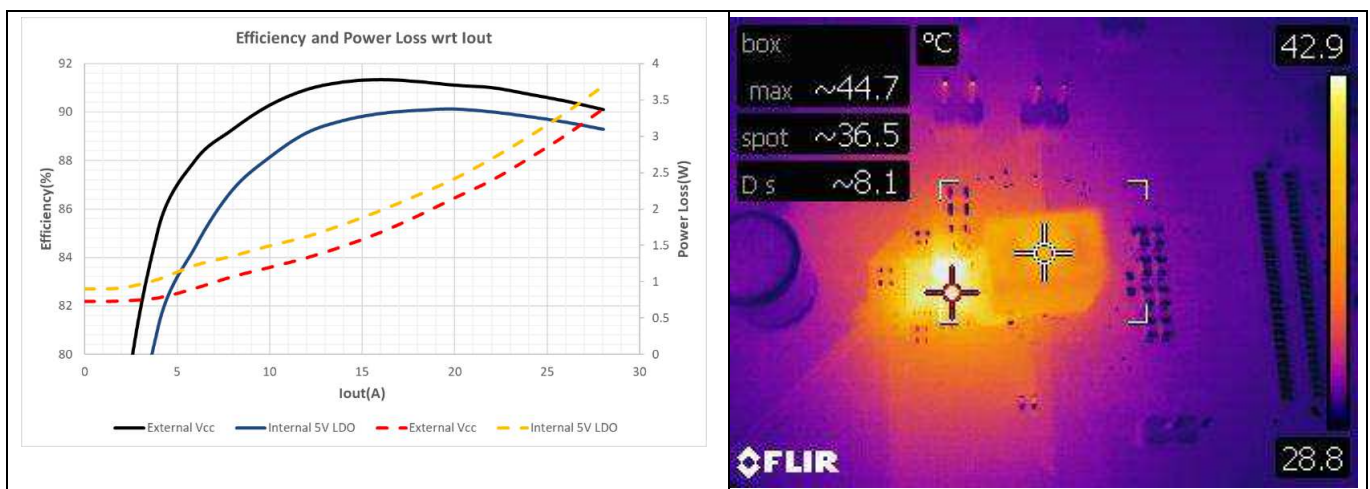

Figure 7 Typical efficiency & power loss curve plus thermal image at full load of 28 A with Internal LDO, $P_{Vin} = 12\text{ V}$, $F_{sw} = 800\text{ kHz}$

8.3 $P_{Vin} = \text{Varying}$, $F_{sw} = 1000\text{ kHz}$

The test for efficiency was done at 0 LFM and the driver losses are included in the efficiency numbers. Solid line indicate efficiency and dashed lines are showing power loss.

Table 9 Inductors for $P_{Vin}=\text{Varying}$, $F_{sw} = 1000\text{ kHz}$

Vout (V)	Lout (nH)	P/N	PVIN(V)	DCR (mΩ)	Inductor Size (mm ³)
1.1 (Int. Vcc)	100	L101247A-100L	10.8	0.125	10 x 6.4 x 12
			12		
			13.2		

Typical Efficiency and Power Loss Curves

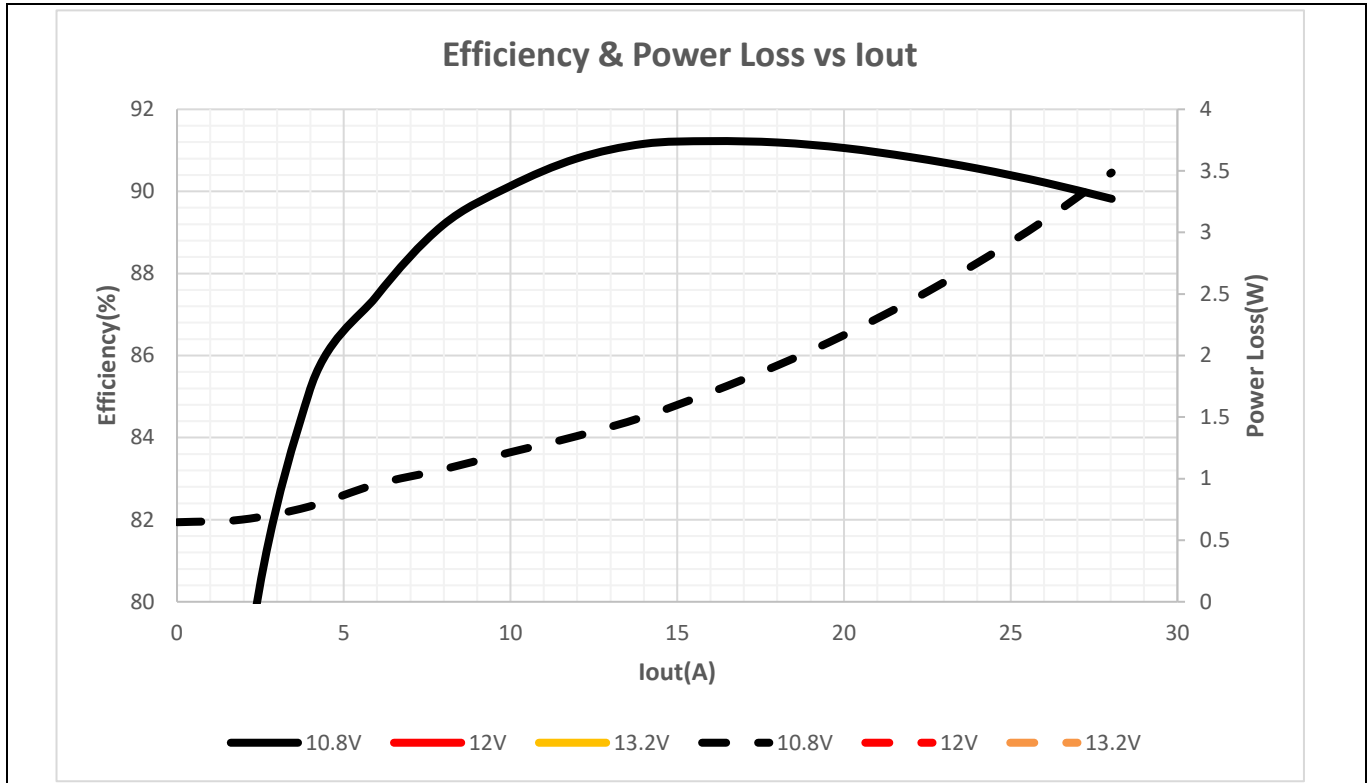

Figure 8 Typical efficiency and power loss curves, $P_{V_{in}}$ = Varying, F_{sw} = 1000 kHz

9 Thermal De-rating curves

This test is done on a DB356 Rev 2 Evaluation Board for TDA38640. It is an 8-layer board with 1 oz inner Cu layers and 2 oz on the top and bottom layer. FR4 material and the size of the eval board is 105 mm x 133 mm.

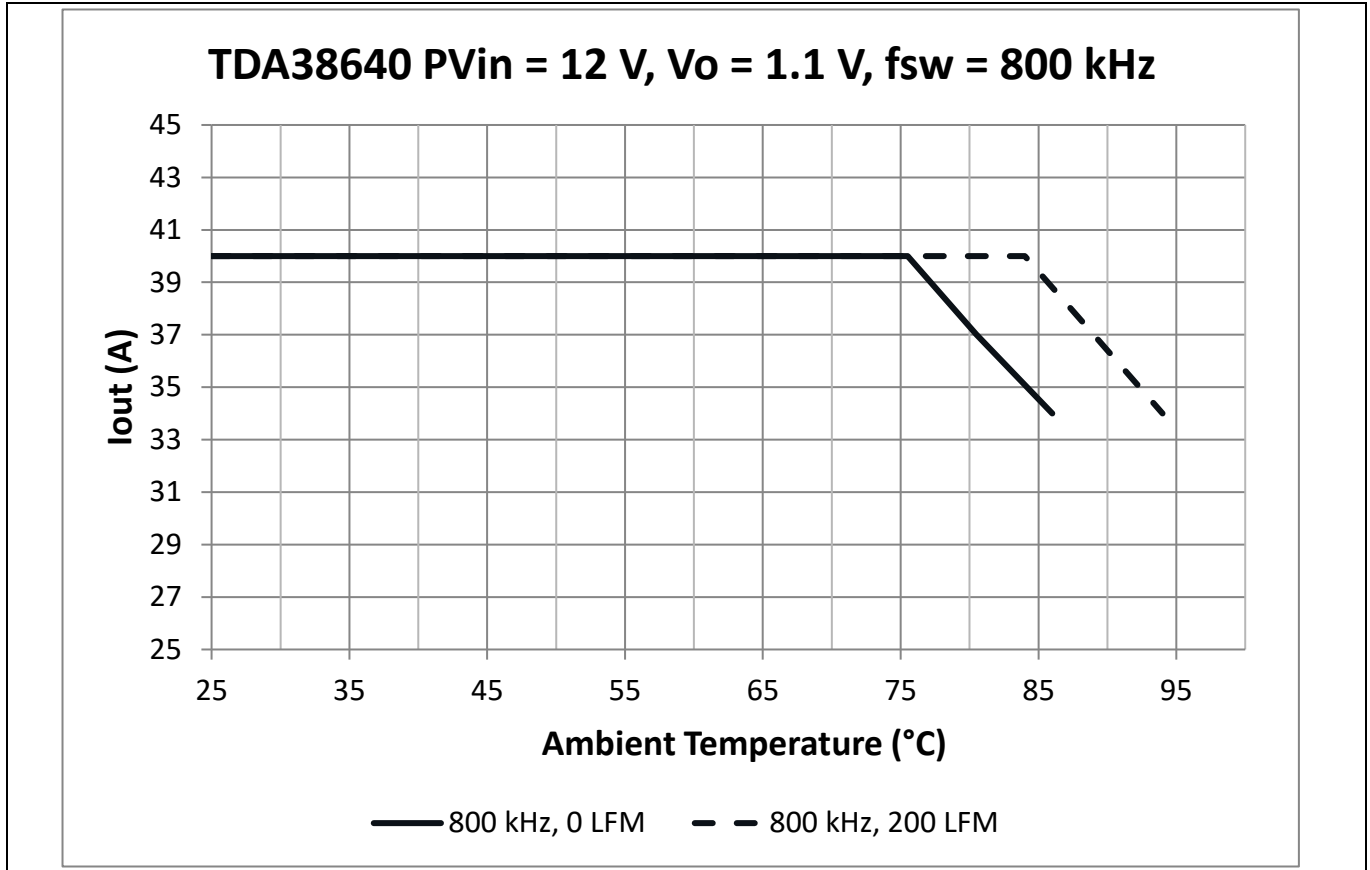

Figure 9 Thermal de-rating curves, $P_{Vin} = 12\text{ V}$, $V_{out}=1.1\text{ V}$, $f_{sw} = 800\text{ kHz}$, $V_{CC} = \text{Internal LDO}$

10 RDS(on) of MOSFET Over Temperature

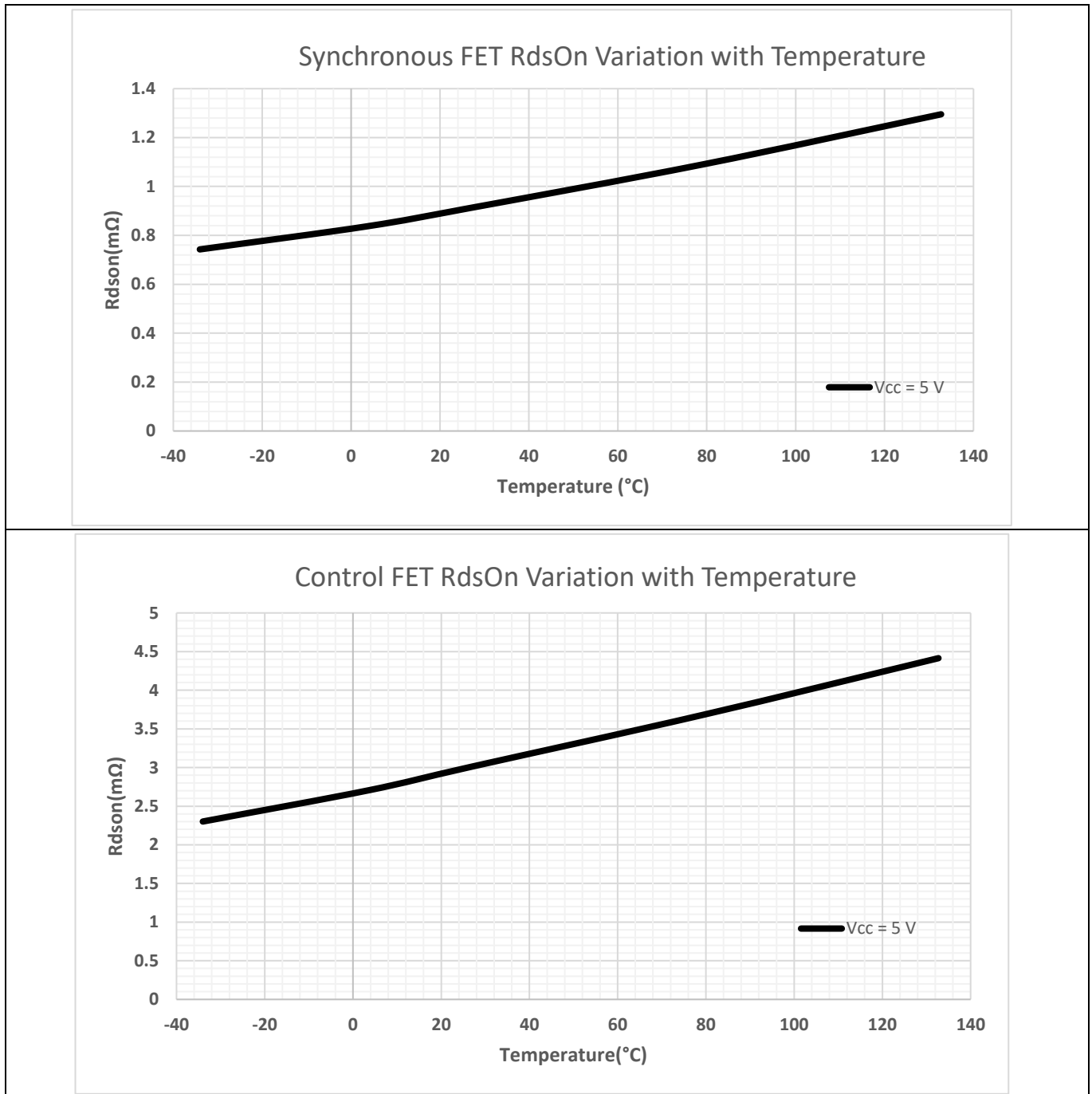

Figure 10 RDS(on) of MOSFETs over Junction Temperature

11 Typical operating characteristics (-40 °C ≤ Tj ≤ +125 °C)

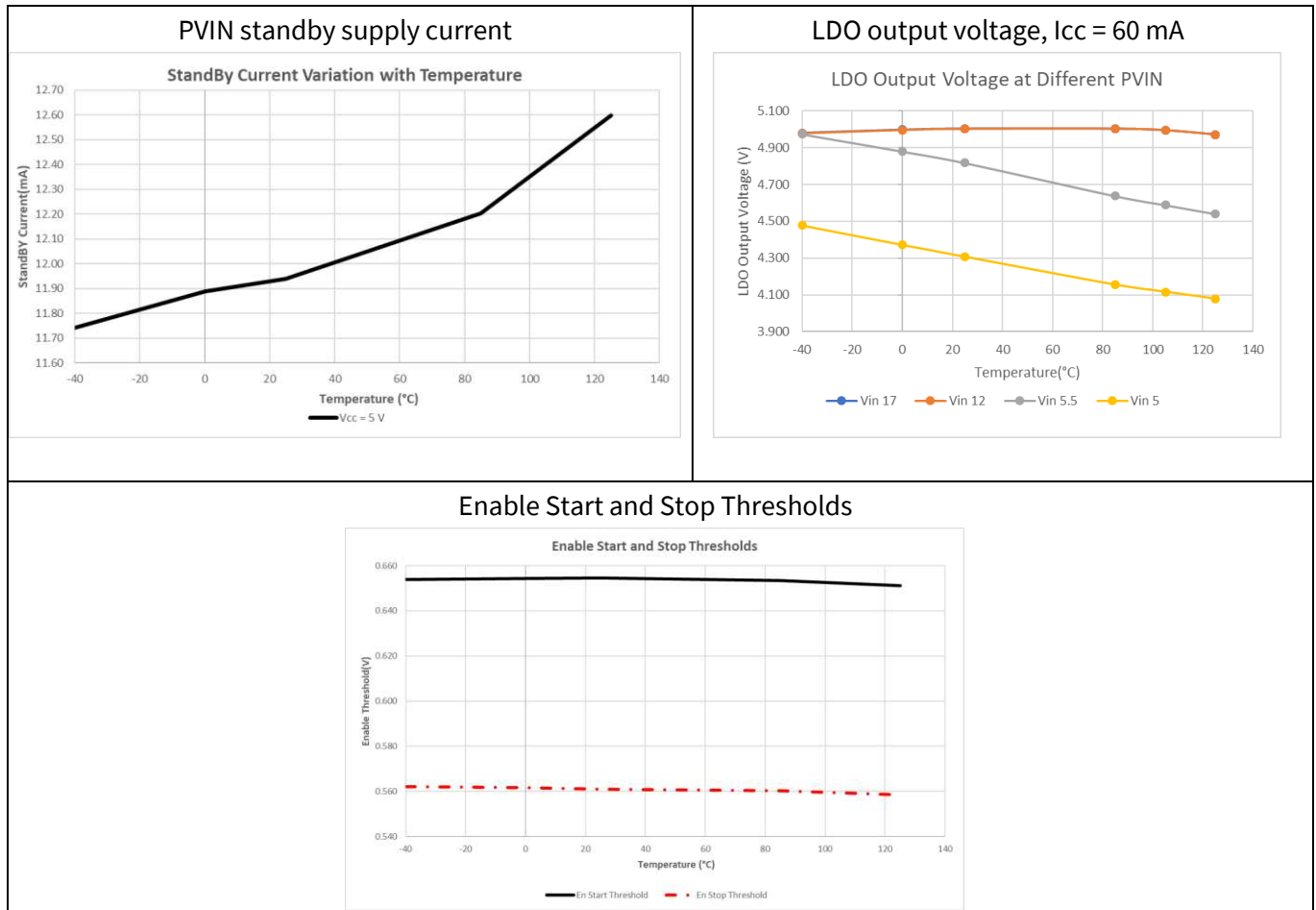

Figure 11 Typical operating characteristics (set 1 of 2)

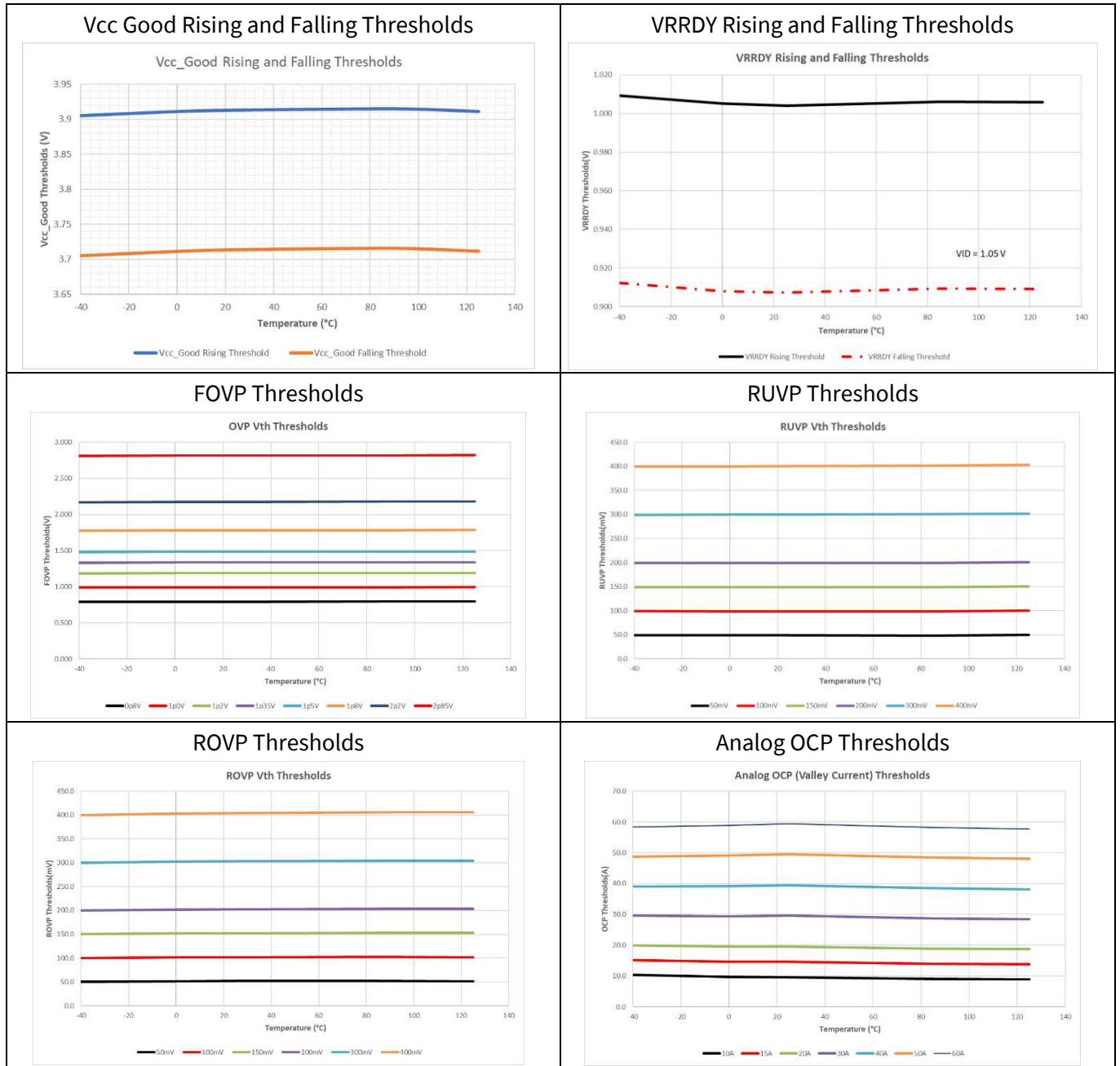

Figure 12 Typical operating characteristics (set 2 of 2)

12 General Description

The TDA38640 is an easy-to-use, fully integrated, and highly efficient dc-dc regulator optimized to convert a 12 V input supply to a voltage level required by high performance microprocessors and DDR memory. The onboard PWM controller and OptiMOS™ FETs with integrated bootstrap diode make TDA38640 a small footprint solution, providing high-efficient power delivery. Using a fast Constant On-Time (COT) control scheme simplifies the design efforts and achieves fast control response. The device configuration can be easily defined using Infineon's XDP Designer GUI and is stored in the on-chip memory.

12.1 Intel Operating Mode

The TDA38640 can be used for Intel® VR12, VR 12.5, VR13, VR14, IMPVP8 designs and DDR Memory without significant changes to the Bill of Materials (BOM). The required mode is selected in MTP and the pin-out, VID table and other relevant functions are automatically configured. This greatly reduces time-to-market and eliminates the need to manage and inventory different PWM controllers.

12.2 PMBUS Operating Mode

The TDA38640 can be used in PMBUS mode. The required mode is selected in MTP using GUI using the register 0x44[15]. In PMBUS mode, the output voltage is controlled by the PMBUS VOUT_COMMAND command. The VOUT_COMMAND resolution can be set to 0.625 mV/lsb, 0.977 mV/lsb, 1.953 mV/lsb, or 3.906 mV/lsb. The output DAC resolution is 1.25 mV/lsb. The resolution is user-programmable via a configuration file. See Table 20 for a full list of all supported PMBUS commands. Please refer to App Note AN_2203_PL12_2204_184108 for more information.

12.3 Multiple Time Programming Memory

The multiple time programming memory (MTP) stores the device configuration. At power-up, MTP contents are transferred to operating registers for access during device operation. MTP allows customization during both design and high-volume manufacturing. MTP integrity is verified by Cyclic Redundancy Code (CRC) checking on each power up. The controller will not start up in the event of a CRC error.

The TDA38640-xxxx allows up to 5 unique configurations to program basic device parameters such as frequency, fault operation characteristics, and boot voltage. This represents a significant size and component saving compared to traditional analog methods. In addition, the TDA38640 also allows loading of multi-image (up to 5 consecutive) configuration files and automatic selection of a unique file after power-up based on the resistor value at the SM-ADDR/PROG pin and the pointer (0x00[13:8]). There are registers available in the CNFG section of the register map which allow the user the capability to set the starting point for a multi-image (register 0x0000[13:8]) and number of images as part of the multi-image config file (register 0x0000[3:0]).

TDA38640-xxxx can be programmed successfully for an application up to 16 times for a single image config file. This should be done during offline programming or by using Infineon programming solution. In addition to this, the TDA38640 also allows loading of multi-image configuration files, limited to a maximum of 5 config files for the multi-image. For any application which needs multi-image configuration, Infineon will establish custom part numbers and will program at Infineon production facility. After soldering parts with a 5-image multi-image, it may be programmed two more times with a single image.

The user still has access to all the possible I2C slave addresses. The user has to use the registers to do this. This requires address offset capability of the SM_ADDR/PROG pin to be disabled by setting the bit 0x42[6] to 1. Thus, the base address register 0x40[14:8] for I2C and 0x40[6:0] for PMBus will represent the effective slave address for the device. In this case the SM_ADDR/PROG effectively becomes just the PROG pin used for selecting the correct config file for an application. For example, for an effective 7-bit I2C address of 14h the register 0x40[14:8] should be set to 14h. The second method for choosing the effective slave address is using the base address in register

General Description

0x40 and adding the offset selected by the SM_ADDR/PROG pin. The pin configuration limits the offset capability available for an application, as shown in Table 13.

12.4 Voltage Sense

An error voltage is generated from the difference between the target voltage, defined by the VID and load line (if implemented), and the differentially sensed output voltage (remote sense). The error voltage is digitized by a high-speed, high-precision ADC. An anti-aliasing filter provides the necessary high frequency noise rejection. The gain and offset of the voltage sense circuitry for each loop is factory trimmed to deliver the required accuracy.

In order to obtain output voltages in the range of 2.56 V – 3.04 V an external feedback resistor network is needed and the device needs to operate in VOUT_SCALE_LOOP 1:2 mode. The feedback resistor values have to be equal and smaller than 500 Ω (recommended is 499 Ω, E96). Furthermore, to achieve tight regulation in VOUT_SCALE_LOOP of 1:2, connect a 31kΩ (1% tolerance) resistor in parallel to the top resistor of the divider. This will compensate for the error caused by impedance of the Analog front end (AFE) circuit.

12.5 VID Decoder

The VID decoder receives a VID code from the CPU that is converted to an internal code representing the VID voltage. The 8-bit VID code supports Intel® VR13, VR14. Also, the user can program 5 mV or 10 mV VID steps depending on the protocol ID selected by the user.

12.6 I2C & PMBus Interface

An I2C or PMBus interface is used to communicate with the TDA38640. This two-wire serial interface consists of clock and data signals, and operates as fast as 1 MHz. The bus provides read & write access to the internal registers for configuration, and for monitoring of operating parameters. The bus is also used to program on-chip non-volatile memory (MTP) to store operating parameters.

To ensure operation with multiple devices on the bus, a base address for TDA38640 is programmed into the MTP. The unique slave address for the device is a combination of the base address in the device register plus the offset generated by the SM_ARR/PROG pin (depending on the resistor value connected to the pin). Another way of doing the same thing is to program the effective I2C address into the base address register and the disable the SM_ADDR/PROG pin offset functionality via a bit in USER section.

To protect customer configuration and information, the I2C interface can be configured for either limited access or locked with a 16-bit software password. Limited access includes both write and read protection options. In addition, there is a telemetry-only mode which only allows reads from the telemetry registers.

Refer to the PMBus Command Codes in Table 20 for more information. One can access the non-PMBus registers (I2C register) via the MFR_REG_ACCESS(D0h) PMBus Command. More information is available in the PMBus Commands document. Setting the base address for PMBus, 0x40[6:0], to zero disables the PMBus interface. If the I2C base address, 0x40[14:8], register is set to 0, the device is forced into test mode. Reserved addresses should be avoided: (0x00 to 0x07), 0x08, 0x0c, 0x28, 0x37, 0x61, (0x78 to 0x7F). All registers at this address are protected by the i2c_pmb_addr_lock register 0xD4[2]. Please refer to the App note AN_2203_PL12_2204_210835 for more information on the register map.

12.7 Infineon XDP Designer GUI

The Infineon XDP Designer GUI provides the designer with a comprehensive design environment that includes input settings, output settings, telemetry, PMBus interface, and SVID settings. With these tools, a designer can monitor and set real-time system configuration settings for fault thresholds and output behavior. The XDP Designer GUI allows real-time design monitoring of key parameters such as output current and power, input current and power, efficiency, temperature, and faults. Figure 13 and Figure 14 show the GUI home screen and

TDA38640 OptiMOS iPOL

40A Single-voltage Synchronous Buck Regulator with SVID and I2C



General Description

design tools with the available parameter windows. The GUI is available to download from Infineon website as part of the Toolbox utility.

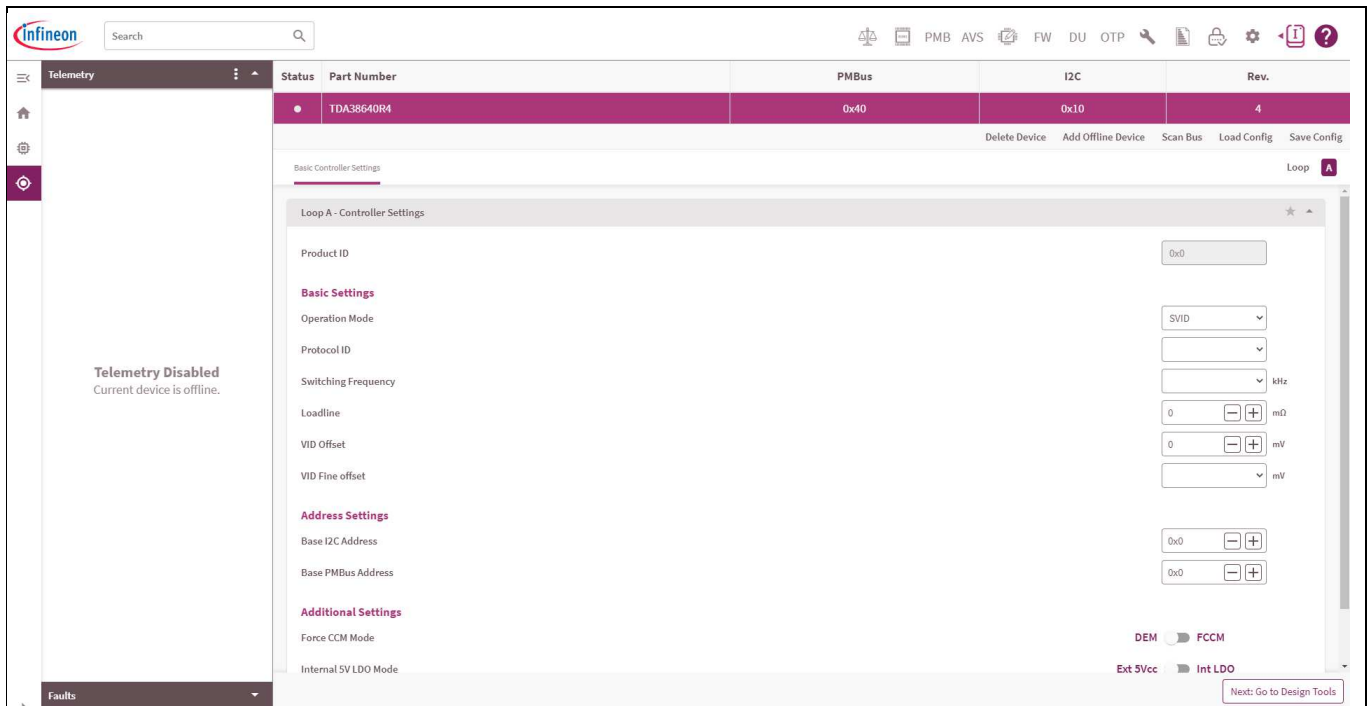

Figure 13 Snapshot of the XDP Designer GUI Home screen for TDA38640 working in Offline Mode

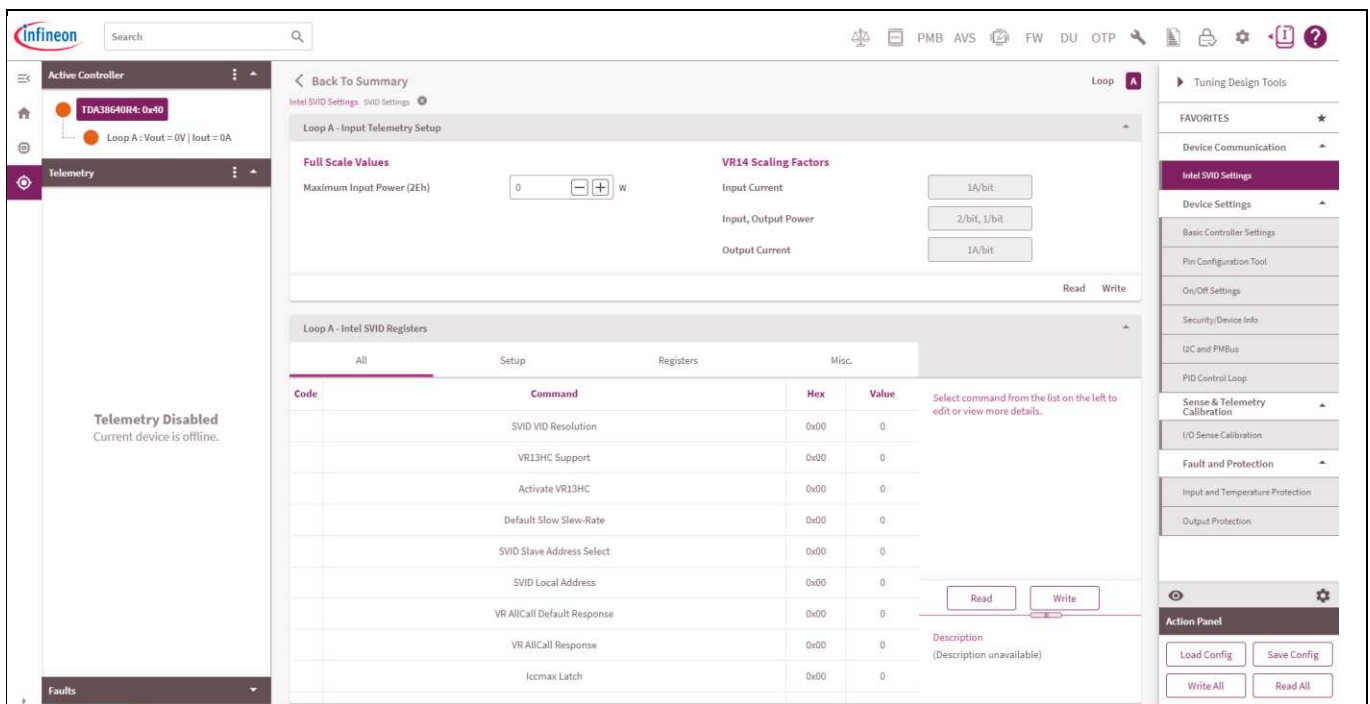

Figure 14 Snapshot of the XDP Designer GUI Design Tools for TDA38640 working in Offline Mode

General Description

12.8 Programming

Once a design is complete, the XDP Designer GUI produces a configuration file. These configurations files can be saved and loaded. Infineon does not recommend loading a new config file and programming the device while the device is operating to produce an output voltage. Please refer to programming guide AN_2204_PL12_2204_185449 for more details.

12.9 Real-time Monitoring

The TDA38640 can be accessed through the use of PMBus Command codes (described in Table 20), to read the real time status of the VR system including input voltage, output voltage, input and output current, input and output power and temperature of the IC.

13 Theory of Operation

13.1 Operating Mode

The TDA38640 changes its functionality based on the user-selected operating mode, allowing one device to be used for multiple applications without significant BoM changes. This greatly reduces the user’s design cycles and time-to-market (TTM).

The functionality for each operating mode is completely configurable by simple selections in MTP. The mode configuration is shown in Table 10. The mode can be selected based on the I2C register 0x44[12:8], this is the protocol- id register which selects the Intel Mode for which the device is being used.

Table 10 Mode Selection

Mode	Description
VR14	Intel® VR14 (Selected via MTP)
VR13	Intel® VR13 (Selected via MTP)
VR12.X	Intel® VR12.X (Selected via MTP)

13.2 Device Power-On

TDA38640 is ready to communicate as soon as Vcc is above the threshold of 3.6 V. The device starts switching once the Enable signal is pulled high. Based on whether Vcc is supplied externally or an internal LDO is used, the recommended power-up sequences are shown in Figure 15.

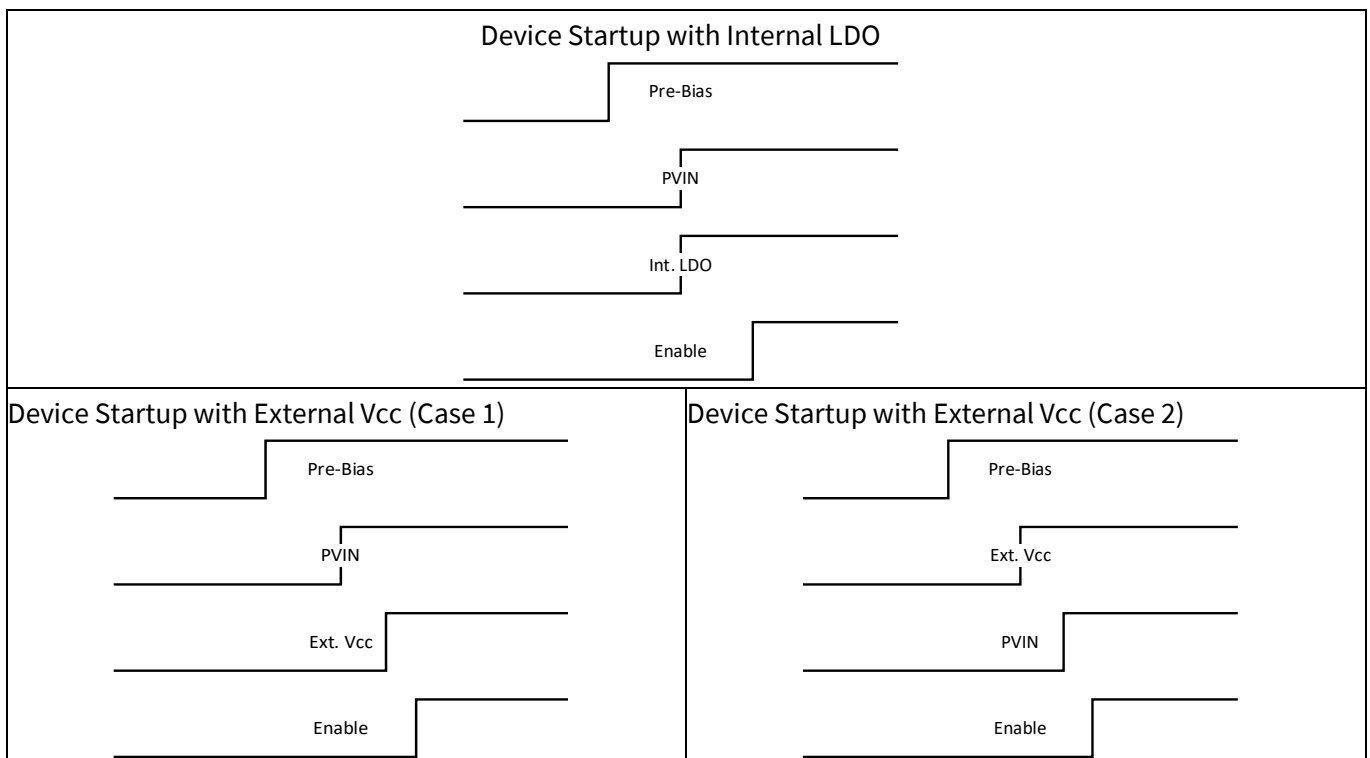

Figure 15 Device power-on sequence with pre-bias.

Theory of Operation

13.3 Pre-bias startup

TDA38640 is able to start up into a pre-charged output without causing oscillations and disturbances of the output voltage upto 0.5V Prebias level.

Prebias operation requirements are:

- The startup sequence should follow the sequencing shown in Figure 15.
- The “power down analog circuit when the output is not enabled” feature should be disabled (set register 0x6C value to 0xF240) in the config file.

For any application needs with Prebias >0.5 V please contact Infineon.

13.4 Internal Low-Dropout (LDO) Regulator

The TDA38640 has an integrated low-dropout LDO regulator, to provide the bias voltage for internal circuitry. When the Vcc UVLO start threshold and the enable voltage is above the Enable threshold, the soft-start sequence starts. When using the internal LDO for a single rail operation, PVIN internally acts as an input to the LDO block. To save the power losses on the LDO, an external bias voltage can be used by connecting it to the VCC/LDO pin. Additionally, it is recommended to set 0x64[3] to 1, this disables the internal LDO operation. Figure 16 illustrates the possible configurations of VCC/LDO, and PVIN pin.

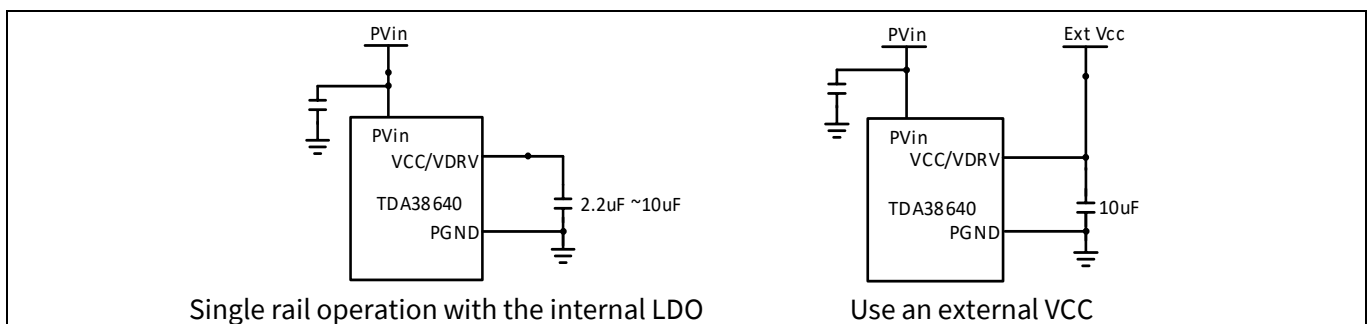

Figure 16 Configuration of using the internal LDO or an external VCC.

13.5 Fast Constant ON-Time Control

The TDA38640 features a proprietary Fast Constant On-Time (COT) Control, which can provide fast load transient response, good output regulation and minimize the design effort. Fast COT control compares the output voltage, V_o , to a floor voltage combined with an internal ramp signal. When V_{out} drops below that signal, a PWM signal is initiated to turn on the high-side FET for a fixed on-time. The floor voltage is generated from an internal compensated error amplifier, which compares the V_{out} with a reference voltage. Compared to the traditional COT control, Fast COT control significantly improves the V_{out} regulation.

13.6 Enable (EN) Pin

The EN pin controls the on/off status of the TDA38640. When the VCC/LDO voltage rises above the VCC_UVLO_Start threshold, the soft-start sequence starts. The EN voltage needs to be toggled when the VCC voltage drops below VCC_UVLO_Stop and rises above the VCC_UVLO_Start threshold to start soft-start sequence.

The EN pin can be configured in four ways. Three of them are as shown in Figure 17. Configuration one is an external logic signal. The second possible configuration derives the enable signal from the PVIN voltage by a resistive divider, R_{EN1} and R_{EN2} . The third one is a direct connection of EN to the PVIN pin. This is useful in space constrained applications. The fourth configuration is control via PMBus register 0x204[7:0] using the PMBus lines. TDA38640 utilizes the PMBus ON_OFF_CONFIG command in combination with OPERATION command, register

Theory of Operation

0x202[7:0], to control the enable digitally. Using this, a preference between hardware or software enable may be established. More information is available in the PMBUs app note AN_2203_PL12_2204_184108.

If not used the EN pin may be left floating. There is an internal 1 MΩ pull down in the IC.

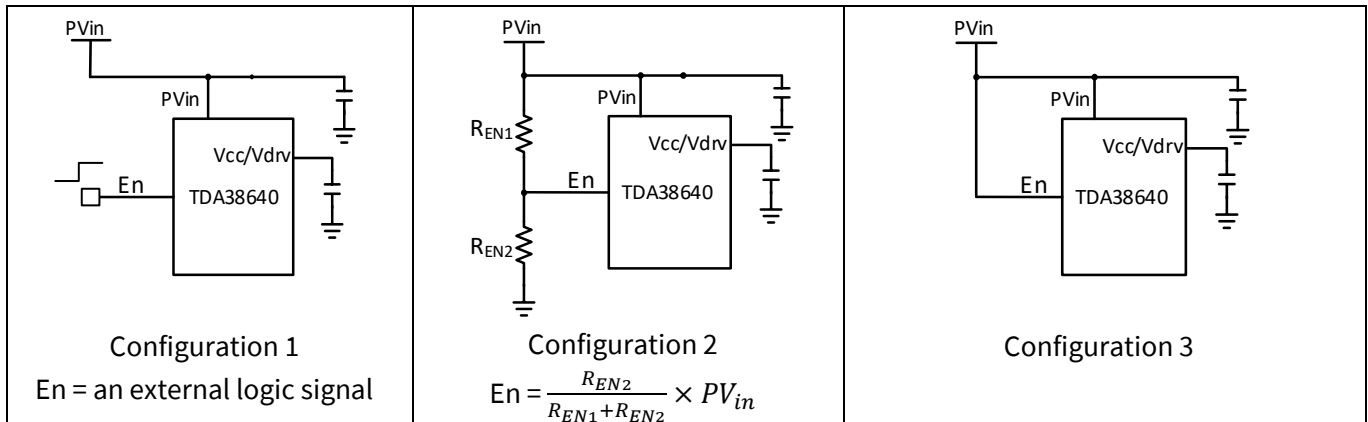

Figure 17 Enable Configurations

13.7 Switching Frequency and FCCM/DEM Operation

TDA38640 offers two operation modes: Forced Continuous Conduction (FCCM) and Diode Emulation Mode (DEM). With FCCM, the TDA38640 always operates as a synchronous buck converter with a pseudo constant switching frequency and therefore achieves small output voltage ripples. In DEM, the synchronous FET is turned off when the inductor current is close to zero, which reduces the switching frequency and improves the efficiency at light load. At heavy load, both FCCM and DEM operate in the same way. The operation mode can be selected by bit 0x5A [1]. Value 1 for this bit programs the device to operate in FCCM mode. Value 0 programs for DEM. It should be noted that the selection of the operation mode cannot be changed on the fly. To load a new configuration, EN or VCC voltage needs to be cycled.

The TDA38640 offers eight programmable switching frequencies, f_{sw} , from 400 kHz to 2 MHz excluding 1600 kHz, by editing the PMBus register, 0x266[16:0], using the I2C lines. Based on the selected f_{sw} , the TDA38640 generates the corresponding on-time of the Control FET for a given PV_{in} and V_o , as shown by the formula below.

$$T_{on} = \frac{V_o}{PV_{in}} \times \frac{1}{f_{sw}}$$

Where f_{sw} is the desired switching frequency. During the operation, the TDA38640 monitors PV_{in} and V_o , and can automatically adjust the on-time to maintain the pre-selected f_{sw} . With the increase of the load, the switching frequency can increase to compensate for the power losses. Therefore, the TDA38640 has a pseudo constant switching frequency.

To load a new TON/MODE configuration, EN or VCC voltage needs to be cycled.

Using the FREQUENCY_SWITCH PMBus command, the switching frequency may be programmed between 400 kHz and 2 MHz in steps of 200Hz except 1600Hz.

13.8 Intel Mode

When the power-on sequence is initiated, and with VBOOT set to > 0 V, the output voltage will ramp to its configured boot voltage and assert VRRDY. The slew rate to VBOOT is programmed per VID_FAST/VID_SLOW commands.

Theory of Operation

If $V_{boot} = 0\text{ V}$, the VR will stay at 0 V and will not soft-start until the CPU issues a VID command to the loop. In VR13 mode, as soon as the IC is ready for SVID communication, $SV_ALERT\#$ will be asserted with $V_{boot} = 0\text{ V}$.

13.8.1 Intel Boot Mode

The TDA38640 V_{boot} voltage is fully programmable in MTP to the range specified in the Intel VID tables. Table 11 and Table 12 show the Intel VID tables for 5 mV and 10 mV VID steps respectively.

13.8.2 Intel SVID Interface

The TDA38640 implements a fully compliant Intel® VR 13, VR12, VR 12.5, and VR14 Serial VID (SVID) interface. This is a 3-wire interface between an Intel processor & VR that consists of clock, data and alert# signals.

The TDA38640 implements all the required SVID registers and commands per Intel specifications. For the selected Intel mode, the TDA38640 also implements most of the optional commands and registers with very few exceptions. The Intel CPU is able to detect and recognize the extra functionality that the TDA38640 provides and thus gives the Intel® VR 14/13/12/12.5 CPU unparalleled ability to monitor and optimize its power.

The SVID address of the TDA38640 defaults to 0. This address can be re-programmed in MTP. An address lock function prevents accidental overwrites of the address.

The pseudo-code below illustrates the MTP address programming:

```
# unlock the address register to write, then lock
Set Address_lock_bit=0
Write new SVID address
```

13.8.3 All Call SUPPORT

All Call for each loop of TDA38640 can be configured in following ways:

- 0E and 0F.
- 0E only.
- 0F only.
- No All Call

TDA38640 can be configured to be used as VR for CPU which is All Call 0F or Memory which is All Call 0E.

13.8.4 VR13 Operation

VR 13 mode is selectable via MTP bit (0x44[12:8]). The boot voltage in VR 13 mode is configured in the boot register. In VR 13 mode, the boot voltage can be configured in 5 mV steps or 10 mV steps.

13.8.5 VR14 Operation

VR 14 mode is selectable via MTP bit (0x44[12:8]). The boot voltage in VR 14 mode is configured in the boot register. In VR 14 mode, the boot voltage can be configured in 5mV steps) or 10mV steps.

13.8.6 Set Work Point

TDA38640 supports SVID Set WP command to Set VID voltage for all rails through all call address. When processor asserts a Set WP command, all the rails of the VR settle to the corresponding new set-voltage encoded in WP registers. Slew rate and power state of all the rails are identical during a set work point operation.

Table 11 Intel 5mV VID Table (VR14 and VR13)

VID (Hex)	Voltage (V)	VID (Hex)	Voltage (V)	VID (Hex)	Voltage (V)	VID (Hex)	Voltage (V)	VID (Hex)	Voltage (V)
FF	1.52	DA	1.335	B5	1.15	90	0.965	6B	0.78
FE	1.515	D9	1.33	B4	1.145	8F	0.96	6A	0.775
FD	1.51	D8	1.325	B3	1.14	8E	0.955	69	0.77
FC	1.505	D7	1.32	B2	1.135	8D	0.95	68	0.765
FB	1.5	D6	1.315	B1	1.13	8C	0.945	67	0.76
FA	1.495	D5	1.31	B0	1.125	8B	0.94	66	0.755
F9	1.49	D4	1.305	AF	1.12	8A	0.935	65	0.75
F8	1.485	D3	1.3	AE	1.115	89	0.93	64	0.745
F7	1.48	D2	1.295	AD	1.11	88	0.925	63	0.74
F6	1.475	D1	1.29	AC	1.105	87	0.92	62	0.735
F5	1.47	D0	1.285	AB	1.1	86	0.915	61	0.73
F4	1.465	CF	1.28	AA	1.095	85	0.91	60	0.725
F3	1.46	CE	1.275	A9	1.09	84	0.905	5F	0.72
F2	1.455	CD	1.27	A8	1.085	83	0.9	5E	0.715
F1	1.45	CC	1.265	A7	1.08	82	0.895	5D	0.71
F0	1.445	CB	1.26	A6	1.075	81	0.89	5C	0.705
EF	1.44	CA	1.255	A5	1.07	80	0.885	5B	0.7
EE	1.435	C9	1.25	A4	1.065	7F	0.88	5A	0.695
ED	1.43	C8	1.245	A3	1.06	7E	0.875	59	0.69
EC	1.425	C7	1.24	A2	1.055	7D	0.87	58	0.685
EB	1.42	C6	1.235	A1	1.05	7C	0.865	57	0.68
EA	1.415	C5	1.23	A0	1.045	7B	0.86	56	0.675
E9	1.41	C4	1.225	9F	1.04	7A	0.855	55	0.67
E8	1.405	C3	1.22	9E	1.035	79	0.85	54	0.665
E7	1.4	C2	1.215	9D	1.03	78	0.845	53	0.66
E6	1.395	C1	1.21	9C	1.025	77	0.84	52	0.655
E5	1.39	C0	1.205	9B	1.02	76	0.835	51	0.65
E4	1.385	BF	1.2	9A	1.015	75	0.83	50	0.645
E3	1.38	BE	1.195	99	1.01	74	0.825	4F	0.64
E2	1.375	BD	1.19	98	1.005	73	0.82	4E	0.635
E1	1.37	BC	1.185	97	1	72	0.815	4D	0.63
E0	1.365	BB	1.18	96	0.995	71	0.81	4C	0.625
DF	1.36	BA	1.175	95	0.99	70	0.805	4B	0.62
DE	1.355	B9	1.17	94	0.985	6F	0.8	4A	0.615

Theory of Operation

VID (Hex)	Voltage (V)	VID (Hex)	Voltage (V)	VID (Hex)	Voltage (V)	VID (Hex)	Voltage (V)	VID (Hex)	Voltage (V)
DD	1.35	B8	1.165	93	0.98	6E	0.795	49	0.61
DC	1.345	B7	1.16	92	0.975	6D	0.79	48	0.605
DB	1.34	B6	1.155	91	0.97	6C	0.785	47	0.6
46	0.595	37	0.52	28	0.445	19	0.37	0A	0.295
45	0.59	36	0.515	27	0.44	18	0.365	09	0.29
44	0.585	35	0.51	26	0.435	17	0.36	08	0.285
43	0.58	34	0.505	25	0.43	16	0.355	07	0.28
42	0.575	33	0.5	24	0.425	15	0.35	06	0.275
41	0.57	32	0.495	23	0.42	14	0.345	05	0.27
40	0.565	31	0.49	22	0.415	13	0.34	04	0.265
3F	0.56	30	0.485	21	0.41	12	0.335	03	0.26
3E	0.555	2F	0.48	20	0.405	11	0.33	02	0.255
3D	0.55	2E	0.475	1F	0.4	10	0.325	01	0.25
3C	0.545	2D	0.47	1E	0.395	0F	0.32	00	0
3B	0.54	2C	0.465	1D	0.39	0E	0.315		
3A	0.535	2B	0.46	1C	0.385	0D	0.31		
39	0.53	2A	0.455	1B	0.38	0C	0.305		
38	0.525	29	0.45	1A	0.375	0B	0.3		

Table 12 Intel 10mV VID Table (VR14 and VR13)

VID (Hex)	Voltage (V)	VID (Hex)	Voltage (V)	VID (Hex)	Voltage (V)	VID (Hex)	Voltage (V)	VID (Hex)	Voltage (V)
FF	3.04	DC	2.69	B9	2.34	96	1.99	73	1.64
FE	3.03	DB	2.68	B8	2.33	95	1.98	72	1.63
FD	3.02	DA	2.67	B7	2.32	94	1.97	71	1.62
FC	3.01	D9	2.66	B6	2.31	93	1.96	70	1.61
FB	3.00	D8	2.65	B5	2.30	92	1.95	6F	1.60
FA	2.99	D7	2.64	B4	2.29	91	1.94	6E	1.59
F9	2.98	D6	2.63	B3	2.28	90	1.93	6D	1.58
F8	2.97	D5	2.62	B2	2.27	8F	1.92	6C	1.57
F7	2.96	D4	2.61	B1	2.26	8E	1.91	6B	1.56
F6	2.95	D3	2.60	B0	2.25	8D	1.90	6A	1.55
F5	2.94	D2	2.59	AF	2.24	8C	1.89	69	1.54
F4	2.93	D1	2.58	AE	2.23	8B	1.88	68	1.53
F3	2.92	D0	2.57	AD	2.22	8A	1.87	67	1.52
F2	2.91	CF	2.56	AC	2.21	89	1.86	66	1.51
F1	2.90	CE	2.55	AB	2.20	88	1.85	65	1.50
F0	2.89	CD	2.54	AA	2.19	87	1.84	64	1.49
EF	2.88	CC	2.53	A9	2.18	86	1.83	63	1.48

Theory of Operation

VID (Hex)	Voltage (V)	VID (Hex)	Voltage (V)	VID (Hex)	Voltage (V)	VID (Hex)	Voltage (V)	VID (Hex)	Voltage (V)
EE	2.87	CB	2.52	A8	2.17	85	1.82	62	1.47
ED	2.86	CA	2.51	A7	2.16	84	1.81	61	1.46
EC	2.85	C9	2.50	A6	2.15	83	1.80	60	1.45
EB	2.84	C8	2.49	A5	2.14	82	1.79	5F	1.44
EA	2.83	C7	2.48	A4	2.13	81	1.78	5E	1.43
E9	2.82	C6	2.47	A3	2.12	80	1.77	5D	1.42
E8	2.81	C5	2.46	A2	2.11	7F	1.76	5C	1.41
E7	2.80	C4	2.45	A1	2.10	7E	1.75	5B	1.40
E6	2.79	C3	2.44	A0	2.09	7D	1.74	5A	1.39
E5	2.78	C2	2.43	9F	2.08	7C	1.73	59	1.38
E4	2.77	C1	2.42	9E	2.07	7B	1.72	58	1.37
E3	2.76	C0	2.41	9D	2.06	7A	1.71	57	1.36
E2	2.75	BF	2.40	9C	2.05	79	1.70	56	1.35
E1	2.74	BE	2.39	9B	2.04	78	1.69	55	1.34
E0	2.73	BD	2.38	9A	2.03	77	1.68	54	1.33
DF	2.72	BC	2.37	99	2.02	76	1.67	53	1.32
DE	2.71	BB	2.36	98	2.01	75	1.66	52	1.31
DD	2.70	BA	2.35	97	2.00	74	1.65	51	1.30
50	1.29	3E	1.11	2C	0.93	1A	0.75	08	0.57
4F	1.28	3D	1.10	2B	0.92	19	0.74	07	0.56
4E	1.27	3C	1.09	2A	0.91	18	0.73	06	0.55
4D	1.26	3B	1.08	29	0.90	17	0.72	05	0.54
4C	1.25	3A	1.07	28	0.89	16	0.71	04	0.53
4B	1.24	39	1.06	27	0.88	15	0.70	03	0.52
4A	1.23	38	1.05	26	0.87	14	0.69	02	0.51
49	1.22	37	1.04	25	0.86	13	0.68	01	0.50
48	1.21	36	1.03	24	0.85	12	0.67	00	0
47	1.20	35	1.02	23	0.84	11	0.66		
46	1.19	34	1.01	22	0.83	10	0.65		

13.9 Program Pin (SM_ADDR/PROG)

A resistor to ground on this pin sets both a fixed I2C slave address offset and selects a configuration from the 5 possible config files in the OTP during power-up. As shown in Table 13 the SM_ADDR pin selects an offset based on the resistor connected to the SM_ADDR/PROG pin. The PROG functionality is used as shown in Table 13 below. For any application which needs multi-image programming, please contact Infineon. For more information please refer to Section 12.3.

Table 13 SM_ADDR/PROG Pin with the consecutive images starting from Config 0 at location 0

Resistor to GND (kΩ)	PROG Functionality	SM_ADDR Functionality: Offset from the Base Address	Programmability Access for Multi-image config file
SHORT	CONFIG0	0	Please refer to Section 12.3 for more details on single image and multi-image programming
5.62	CONFIG1	1	
9.53	CONFIG2	2	
14	CONFIG3	3	
21	CONFIG4	4	
30.1	CONFIG5	5	
36.5	CONFIG6	6	
43.2	CONFIG7	7	
51.1	CONFIG8	8	
61.9	CONFIG9	9	
75	CONFIG10	10	
88.7	CONFIG11	11	
105	CONFIG12	12	
127	CONFIG13	13	
150	CONFIG14	14	
FLOAT	CONFIG15	15	

13.10 Soft Start

The soft-start functionality is defined to support SVID commands for soft-start SetVID_Slow (0x44[1:0]) and SetVID_Fast (0x46[15:12]) commands are used to set the soft start timing to VID.

13.11 Load-line

TDA38640 offers digital load line which can be set via configuration registers, without any need for external components. The load line can be programmed from 0 to 10 mΩ at a resolution of 19.53 μΩ using the VOUT_DROOP command 0x250[15:0]. The range and resolution of the VOUT_DROOP may be increased by using the bit loadline_range_sel 0x6A [6] to 0 to 50 mΩ at a resolution of 100 μΩ. In addition to this, the bandwidth of the digital load line is also programmable from 30 kHz to 500 kHz in steps of 30 kHz by using 4 bits of register 0x6A [3:0].

13.12 Output Voltage Differential Sensing

The TDA38640 VSEN and VRTN pins are connected across the output capacitors near the load to provide true differential remote voltage sensing with high common-mode rejection. Fast COT control compares the output voltage to a floor voltage combined with an internal ramp signal. When Vout drops below that signal, a PWM signal is initiated to turn on the high-side FET for a fixed on-time. The floor voltage is generated from an internal compensated error amplifier, which compares the Vout with a reference voltage. As shown in Figure 18, the output sense pins VOSENp and VOSENm are connected across the output capacitors.

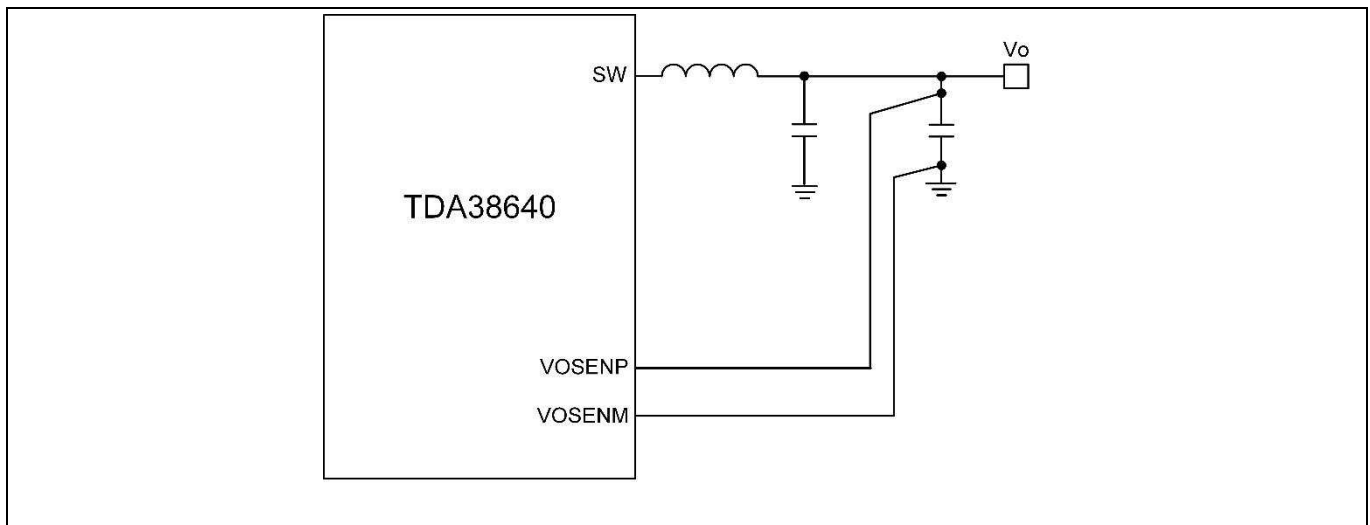

Figure 18 Output voltage sensing connections

13.13 Input Current Sensing

The TDA38640 can measure input current using a measured value from a shunt resistor and/or calculate it using other known variables. The input current sense mode is controlled by the register `iin_sense_mode`, with options outlined in Table 14.

Table 14 Register `iin_sense_mode` options.

Value	Mode
3, 2	Calculated and external resistor sense
1	External resistor sense
0	Calculated

The “lossless input current estimation” scheme can accurately calculate the actual input current as it knows the value of output current, output voltage, input voltage and pulse width of each phase. This eliminates the need for a dedicated shunt. The `IINSEN` pin also simplifies board layout by eliminating additional components. It is recommended to use the value 1 for register `iin_sense_mode` when utilizing this feature in the part for input current sensing. The pins `VINSEN` and `VINSEN` should be tied to `PVIN` and the register `iin_sense_mode`, should set to 0 if the feature needs to be disabled for a particular rail in an application.

Register `iin_rsense_value` controls the external resistor value used for sensing. There is also offset and gain correction that is provided to the user via the `iin_offset_user` (`0x66[13:8]`) and `iin_gain_user` (`0x66[7:4]`) registers respectively.

Table 15 summarizes the usable external resistor values from `iin_rsense_value` (`0x66[3:0]`).

Figure 19 shows the generic application circuit for input current sensing in a typical application.

Table 15 Usable external input current sense resistors, from register `iin_rsense_value`.

Value	Threshold	Value	Threshold
11-15	10 mΩ	5	4 mΩ
10	9 mΩ	4	3 mΩ
9	8 mΩ	3	2 mΩ
8	7 mΩ	2	1 mΩ

Theory of Operation

Value	Threshold	Value	Threshold
7	6 mΩ	1	0.5 mΩ
6	5 mΩ	0	0.2 mΩ

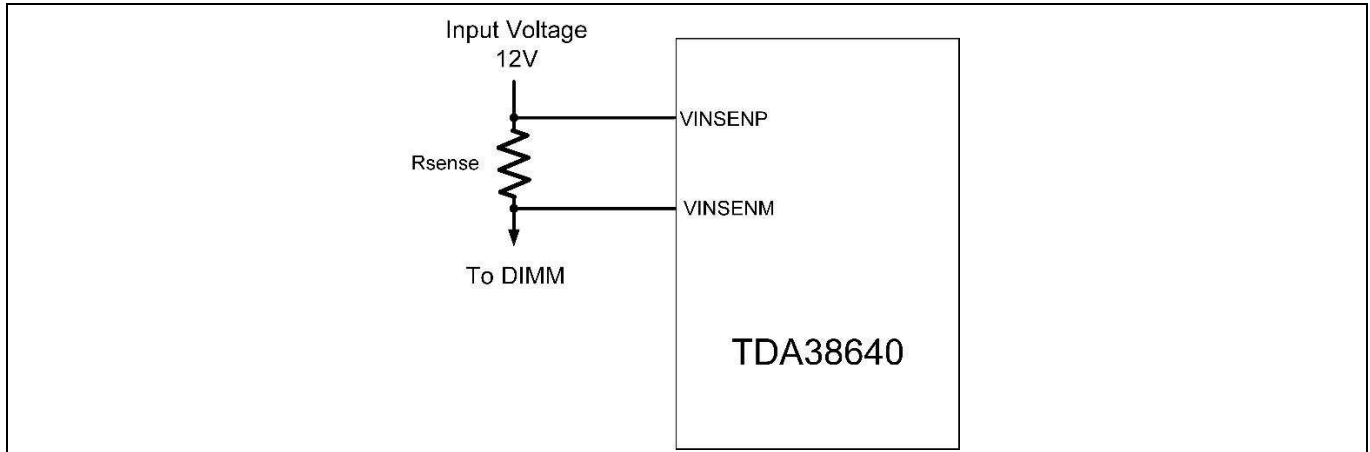

Figure 19 Input current sensing using external shunt

13.14 CAT_FAULT# and VRRDY

TDA38640 supports CAT_FAULT functionality. This is an additional indication of a fault which the system can use to take an action. CAT_FAULT is an open drain output and is pulled high to 3.3 V in the system. In case of a fault, this active low signal is asserted. The conditions under assertion are shown below in Table 16. The functionality is further defined in the VR14 PWM document. CAT_FAULT# is asserted for a high side short during startup. To reset CAT_FAULT# when external Vcc is used, PVIN must be cycled below 4.0V. For rails using the internal LDO, a PVIN cycle is needed to reset CAT_FAULT#.

VRRDY is Intel’s equivalent of PGOOD. The electrical characteristics for the signal are defined in detail in the Intel VR14 PWM document. It is an open drain output pulled up to 3.3 V. When the power-on sequence is initiated, and with VBOOT set to > 0V, the output voltage will ramp to its configured boot voltage and assert VRRDY.

Table 16 VRRDY and CAT_FAULT# Response to Faults

Type of Fault	VRRDY Pin Functionality	CATFLT# Pin Functionality	Device Behavior after event
OVP	This pin is de-asserted	This pin is asserted	Latched Shutdown
OCP	This pin is de-asserted	This pin is asserted	Latched Shutdown
UVP	This pin is de-asserted	This pin is asserted	Latched Shutdown
Boot UVLO	This pin is de-asserted	This pin is asserted	Latched Shutdown
Vcc UVLO	This pin is de-asserted	This pin is asserted	Latched Shutdown
OTP	This pin is de-asserted	This pin is asserted	Latched Shutdown

14 Faults and Protection

14.1 Over Current Protection (OCP)

The TDA38640 has two levels of OCP protection: Analog OCP (AOCP) and Digital OCP (DOCP). The AOCP current limit is based on valley inductor current, whereas the DOCP is based on average current information. AOCP is a fast fault response and should be set to a value that prevents failure of the device.

The scheme allows reconstruction of the inductor current from the voltage sensed across the Sync FET $R_{DS(on)}$. It should be noted here that it is this reconstructed average inductor current that is digitized by the ADC and used for output current reporting.

The over current (OC) fault protection circuit also uses the voltage sensed across the $R_{DS(on)}$ of the Synchronous MOSFET; however, the protection mechanism relies on a fast comparator to compare the sensed signal to the over current threshold and does not depend on the ADC or reported current. The current limit scheme uses an internal temperature compensated current source that has the same temperature coefficient as the $R_{DS(on)}$ of the Synchronous MOSFET. As a result, the over current trip threshold remains almost constant over temperature.

The TDA38640 AOCP can be accessed via three bits in the register map (`aocp_thresh_sel [0:2]`). The digital OCP (DOCP) is available via the PMBus register `IOUT_OC_FAULT_LIMIT`, and the response is decided by `IOUT_OC_FAULT_RESPONSE`. Available responses are shutdown, retry 6 times and latch off, or retry indefinitely. The indication of the fault is available in the `STATUS_IOUT` register in PMBus.

AOCP shall be enabled during soft-start and normal operation including FCCM and DEM modes. When AOCP is crossed, the low side MOSFET will continue to stay on for the remaining cycle and the following high side pulse will be ignored to allow inductor relaxation (pulse skipping). If an AOCP condition is detected on the rising edge of a PWM pulse, the high side will still be blocked from turning on and the pulse will be skipped.

The high side will continue to be ignored if the current remains above the AOCP threshold. A 10-count counter is implemented to count 10 AOCP events, then a signal is sent to the digital block to perform the programmed response. The counter is reset after 3 consecutive non-OCP events. The count occurs at the valley of the current. Note that COT switching frequency will decrease when skipping pulses. Figure 20 is an example AOCP response.

Cycle-by-cycle OCP response allows the TDA38640 to fulfill a brief high current demand, such as a high inrush current during the startup. The Output slew rate and the output capacitance will affect the AOCP during startup. At higher output voltages with no-load, a higher slew rate or a higher output capacitance can trigger AOCP at startup. The `TON_RISE` time should be increased or reduce output capacitance to avoid false triggering of AOCP.

The AOCP is activated when EN voltage is above its threshold. During AOCP events, the valley of the inductor current is regulated around the AOCP limit. But during the first switching cycle when the AOCP is tripped, the valley of the inductor current can drop slightly below the AOCP limit. It should be noted that AOCP events do not pull the `VRRDY` signal low unless the output voltage eventually drop below the Under-Voltage Protection (UVP) threshold and trigger UVP. The response is also shown in Figure 20.

The OCP limits are thermally compensated. The corresponding output dc current can be calculated as follows:

$$I_{out_OCP} = I_{LIM} + \frac{\Delta i_L}{2}$$

Where: I_{out_OCP} = Output dc current when AOCP is tripped. I_{LIM} = AOCP limit, which is the valley of inductor current. Δi_L = Peak-peak inductor ripple current.

To avoid inductor saturation during AOCP events, the following criterion is recommended for the inductor saturation current rating.

$$I_{sat} \geq I_{LIM_max} + \Delta i_L$$

Faults and Protection

Where: I_{sat} is the inductor saturation current and I_{LIM_max} is the maximum spec of the AOC limit.

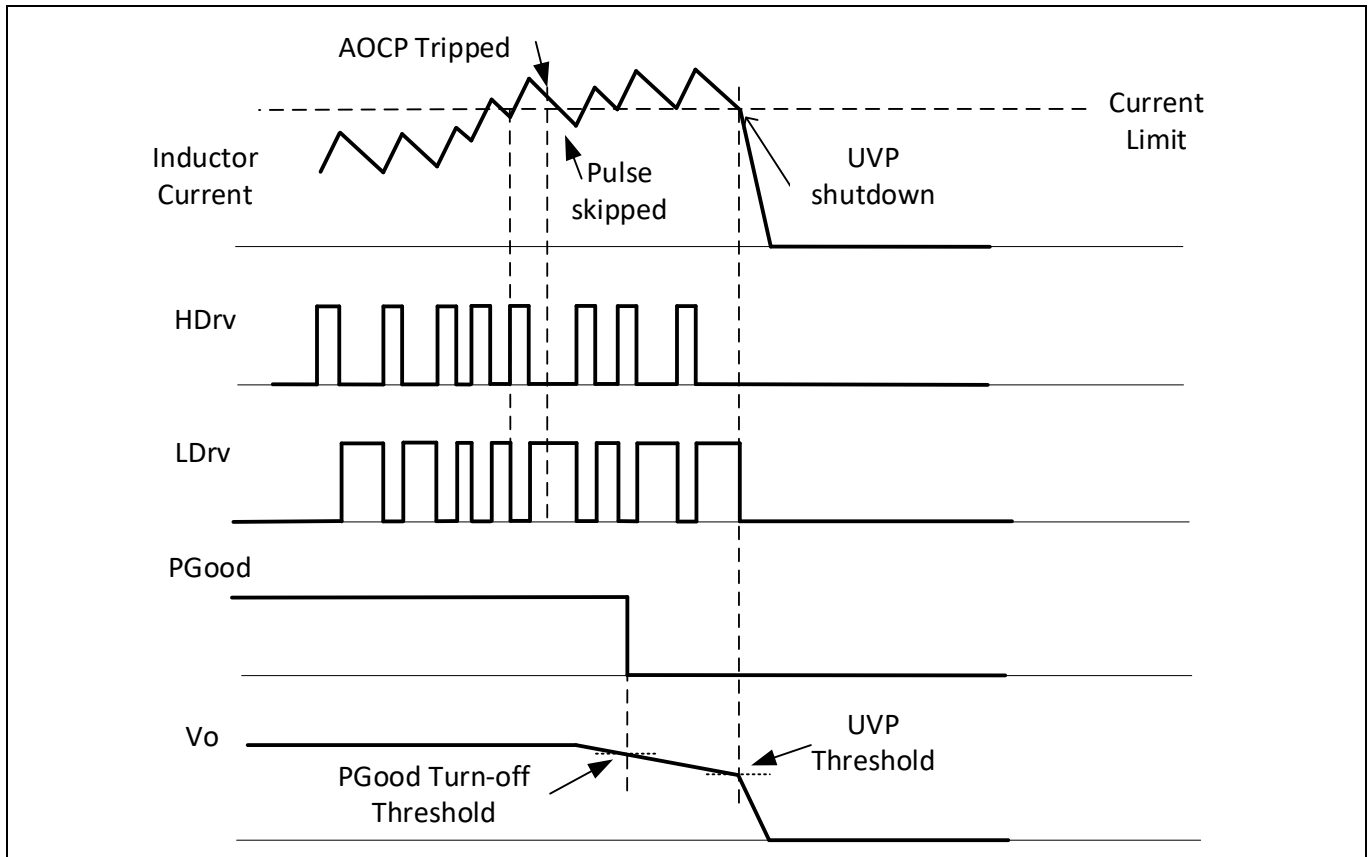

Figure 20 AOC response timing diagram.

14.2 Output Under Voltage Protection (UVP)

The TDA38640 UVP response is a relative limit configurable from 50 mV to 400 mV in steps of 50 mV. The limit is programmed via the VOUT_UV_FAULT_LIMIT PMBus command, and the response is programmed via the VOUT_UV_FAULT_RESPONSE command. There is also the option to program the UVP Limit for the part by accessing the I2C register in the common regmap space. The UVP threshold is enabled using the relative_uvp_thresh_en (0x5E [15]) bit and the levels are set by the relative_uvp_thresh [2:0] (0x5E [10:8]) bits. Possible responses are ignore, shutdown, and retry indefinitely. The relative UVP may be disabled using the disable_relative_UVP(0x60[14]) bit.

When the UVP fault is triggered, a flag is raised and the part is tri-stated until the flag is cleared using the PMBus CLEAR_FAULTS command and the part is started again by either cycling the Vcc or the EN signal to the part. The shutdown response entails tri-stating both the MOSFET's and discharging the output either via a bleed resistor at the output or through the body diode of the low side FET.

If the response is set to retry, a user defined timer (1 ms to 8 ms in steps of 1 ms) is started as soon as the UVP fault is triggered and the output is tri-stated. At the end of the timer the output is checked against a fixed level of 250 mV. If the output is below this voltage the startup sequence is initiated or else the timer is reset and the output tri-state continues (both the MOSFET's are tri-stated).

There are options for UVP protection to be lifted during voltage transitions (Vboot, DVID up and/or down) using the register bits blank_uv_sel [1:0]. The options for this register are outlined in Table 17.

Table 17 Optional UVP blanking via register blank_uv_sel (0x60[11:10]).

Faults and Protection

sel	Description
3	blank UV faults during DVID up or down (including Vboot)
2	blank UV faults during DVID up (including Vboot)
1	blank UV faults during Vboot
0	no UV fault blanking

14.3 Over Voltage Protection (OVP)

The OVP response is divided into two parts: Fixed OVP (FOVP) and Relative OVP (ROVP). The Fixed OVP is typically used for startup, all DVIDs, and when EN is low. ROVP covers all other situations during operation. Figure 21 depicts an example of when FOVP and ROVP are utilized.

The FOVP has 8 distinct levels (0.8 V, 1 V, 1.2 V, 1.35 V, 1.5 V, 1.8 V, 2.2 V, and 2.85 V) with VOUT_SCALE_LOOP in 1:1 mode. The levels are 2x in 1:2 mode. It is programmable via fixed_ovp_thresh [2:0] in configuration register 0x60. The response to an OVP event is programmed via the VOUT_OV_FAULT_RESPONSE command. OVP can have four responses: ignore, shutdown, and retry n (max 6) times after n (defined by PMBus) seconds before latching and retry forever. The threshold for ROVP is relative to the programmed output voltage, and can be set from 50 mV to 400 mV in steps of 50 mV using the I2C register relative_ovp_thresh [2:0] (0x5e [14:12]). The OVP fault can also be blanked by using the bits [13:12] of register 0x60 in common regmap space. Please refer to Table 18 for more details. The PMBUs commands could be over-ridden by using the relative_ovp_thresh_en (0x5e [15]) bit to override the PMBUs commands.

Table 18 Optional OVP blanking via blank_ov_sel(0x60[13:12])

sel	Description
3	blank OV faults during DVID up or down (including Vboot)
2	blank OV faults during DVID up (including Vboot)
1	blank OV faults during Vboot
0	no OV fault blanking

When the output triggers an FOVP event, the OVP flag is set, the low side switch is turned ON and the high side switch is turned OFF. The low side switch is turned ON till the output voltage is dragged down to the set FOVP threshold. The output voltage then decreases to zero with its natural decay.

When the output triggers an ROVP event, the VID set point is moved to 0 V at a controlled slew rate of 30 V/ μ S and the OVP flag is set. Next, the low side switch is turned ON and the high side is turned OFF. This allows the output to discharge until VID set point reaches zero or Vout catches up with the VID set point at which point the low side and high side switched turn ON and OFF as required to maintain the output at the VID set point. How fast the output voltage discharges during this event is determined by the by the output voltage, output capacitance and output inductor. This determines if the output voltage indeed is dragged down to zero by the end of the controlled VID ramp down. At the end of the ramp, if the output is not already dragged down to zero, the output voltage will decrease to zero with its natural decay.

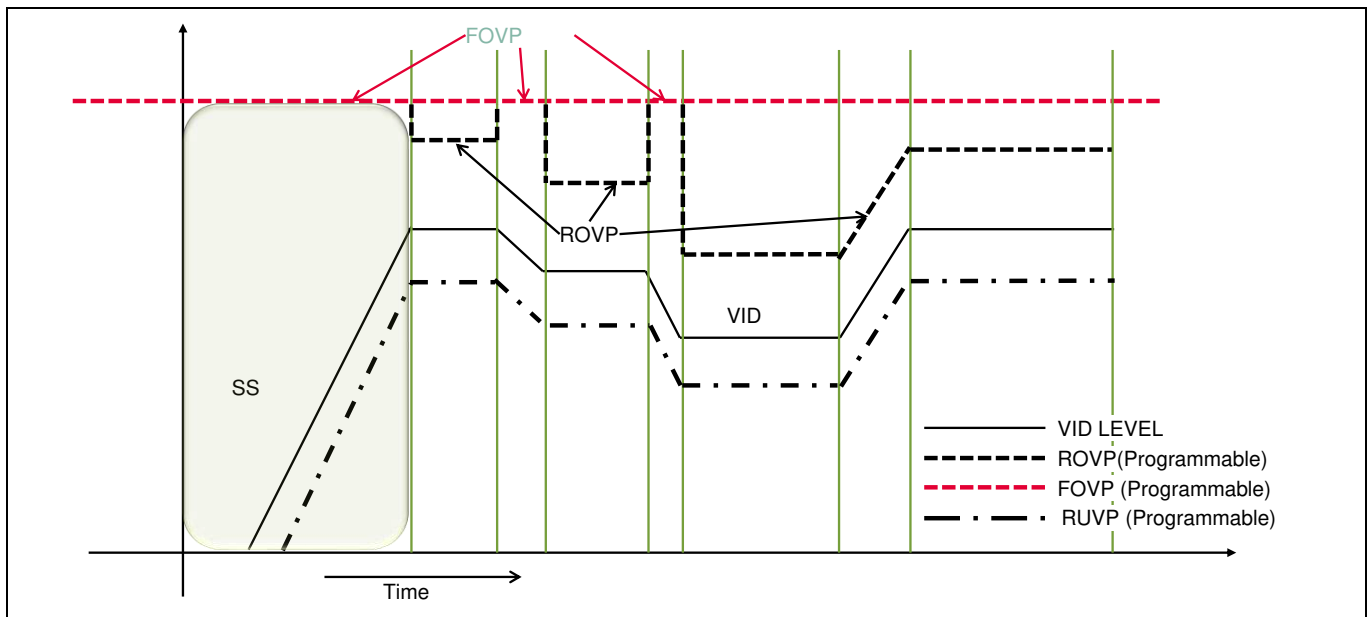

Figure 21 OVP and RUVP example diagram. Note the situations in which FOVP takes over from ROVP.

14.4 Over Temperature Protection (OTP)

Temperature protection is programmable via the OT_FAULT_LIMIT, OT_WARN_LIMIT, and OT_FAULT_RESPONSE PMBus registers. The TDA38640 supports three responses: ignore, shutdown, and retry indefinitely. The fault is non-latching.

An OTP event is triggered when the device temperature reaches the OT_FAULT_LIMIT. The switching output is tri-stated and the output discharges, while staying biased with the internal LDO on. With the output off, the device cools until reaching the OT_WARN_LIMIT, and if set to retry, the device will hiccup with potential of pre-biased startup. For this part the OT_FAULT_LIMIT is set to 140°C by default with a 20°C hysteresis.

14.5 Boot Under Voltage Lockout (UVLO)

The voltage from the BOOT pin to PHASE pin is monitored on the TDA38640. If the UVLO Boot lower threshold violation is detected within the PWM cycle, the event is counted and a fault is asserted after 10 violations. After 3 consecutive cycles without a UVLO BOOT event (above the lower threshold during the PWM cycle), the counter resets. To clear the fault, Vcc or EN has to be cycled. The Boot UVLO fault is in the fail_code_sticky register.

14.6 Minimum On - Time and Minimum Off - Time

The minimum on-time refers to the shortest time for Control MOSFET to be reliably turned on. The minimum off-time refers to the minimum time duration in which the Synchronous FET stays on before a new PWM pulse is generated. The minimum off-time is needed for TDA38640 to charge the bootstrap capacitor, and to sense the current of the Synchronous MOSFET for OCP.

For applications requiring a small duty cycle, it is important that the selected switching frequency results in an on-time larger than the maximum spec of the minimum on-time in the Section 7.1. Otherwise the resulting switching frequency may be lower than the desired target. The following formula could be used to check for the minimum on-time requirement.

$$\frac{V_0}{k f_{sw} \times V_{in}} > \max \text{ spec of } T_{on(\min)}$$

Faults and Protection

Where f_{sw} is the desired switching frequency, and k is the variation of the switching frequency. As a rule of thumb, select $k = 1.25$ to ensure the design margin.

For applications requiring a high duty cycle, it is important to make sure a proper switching frequency is selected so that the resulting off-time is longer than the maximum spec of the minimum off-time in the Section 6, which can be calculated as shown below.

$$\frac{V_{in} - V_0}{kf_{sw} \times V_{in}} > \max \text{ spec of } T_{off(\min)}$$

Where f_{sw} is the desired switching frequency, and k is the variation of the switching frequency. As a rule of thumb, select $k = 1.25$ to ensure the design margin.

The resulting maximum duty cycle is therefore determined by the selected on-time and minimum off-time.

$$D_{max} = \frac{T_{on}}{T_{on} + T_{off(\min)}}$$

14.7 High-Side Short (HSS) Detection

The TDA38640 offers high-side FET short detection. The phase pin is monitored when the low-side FET is active. HSS monitoring happens both at startup and during normal operation. In an HSS event, the HSS threshold is reached and both VRRDY and CAT_FAULT# pins are asserted. In the case of an HSS event during startup, the response is communicated via the CAT_FAULT# pin. Once the HSS threshold is reached, the low-side FET is turned on and the switching stops. There is no current reporting during this time. The fault is sticky and only clears when either the VCC or EN signal is cycled.

Fault Communication

15 Fault Communication

The TDA38640 supports OCP, OVP, UVP, OTP, BOOT UVLO, and Vcc UVLO via telemetry.

15.1 I2C Slave Addressing

The TDA38640 simultaneously supports I2C and PMBus through the use of exclusive addressing. By using a 7-bit address, the user can configure the device to any one of 127 different I2C addresses. Once the address of the TDA38640 is set, it can be locked to protect it from being overridden. Optionally, a resistor can be tied to the SM_ADDR/PROG pin to generate an offset as shown in Table 19.

As an example, setting a base 7-bit I2C address of 28h with a resistor offset of +15 sets the 7-bit I2C address to 37h. There is an option to disable the offset functionality on the SM_ADDR pin by using the `i2c_disable_addr_offset` (0x42[6]) bit from common regmap space. When this bit is enabled an offset is added to the base address for i2c depending upon the resistor connected to the SM_ADDR/PROG pin.

Table 19 Disable Offset Options (0x42[6])

Enable I2C_use_addr_offset bit	I2C Address Offset
0	enabled
1	disabled

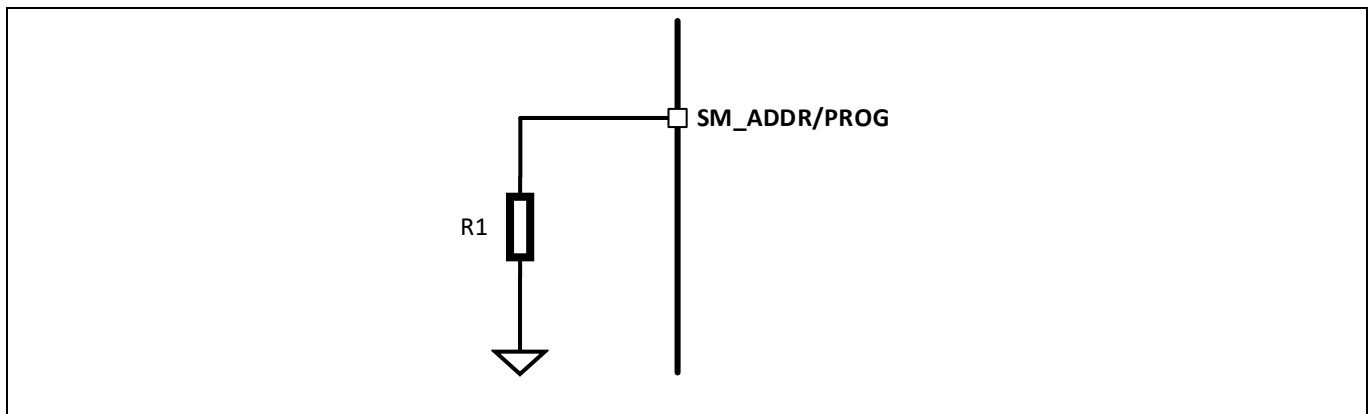

Figure 22 SM-ADDR/PROG Pin Components

15.2 Real-Time Telemetry

TDA38640 provides real-time accurate measurement of input voltage, input current, output voltage, output current temperature, output power, and input power over the I2C interface. Output voltage is calculated based upon the VID setting and the result is reported through the I2C. In the SVID domain, the TDA38640 supports output voltage, output current, input voltage, input current, and input power telemetry.

15.3 I2C Protocol

All registers may be accessed using either I2C or PMBus protocols. I2C allows the use of a simple format whereas PMBus provides error checking capability. Figure 23 shows the I2C format employed by the TDA38640.

Fault Communication

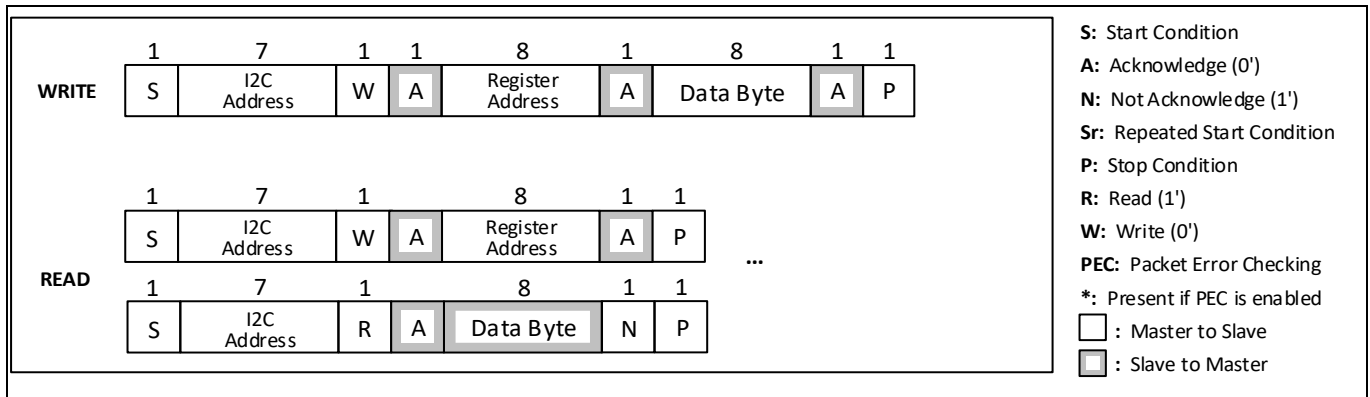

Figure 23 I2C Format

15.4 PMBus Commands Supported

Table 20 lists all the PMBus commands which are supported by the device.

Table 20 PMBus Commands Supported

I2C Register Address	COMMAND	PMBus PROTOCOL	PMBus COMMAND CODE	DESCRIPTION
0x200	PAGE	Read/Write Byte	00h	Allows access of each loop via paging.
0x202	OPERATION	Read/Write Byte	01h	Enables or disables the output and controls margining. Ignores OVP on Margin High, UVP on Margin Low.
0x204	ON_OFF_CONFIG	Read/Write Byte	02h	Configures the combination of CONTROL pin and OPERATION command needed to turn the unit on and off.
0x206	CLEAR FAULTS	Send Byte	03h	Clear contents of Fault registers
0x20A	PAGE_PLUS_WRITE	Write Block	05h	Set the PAGE within a device, send a command, and send the data for the command in one packet.
0x20C	PAGE_PLUS_READ	Block Write/ Block Read Process Call	06h	Set the PAGE within a device, send a command, and read the returned data by the command in one packet
0x220	WRITE_PROTECT	Read/Write Byte	10h	Protects from overwriting the configuration files and modes accidentally
0x222	STORE_DEFAULT_ALL	Sen Byte	11h	Instructs the device to copy the entire contents of the configuration registers to the NVM
0x224	RESTORE_DEFAULT_ALL	Send Byte	12h	Reloads the OTP
0x22A	STORE_USER_ALL	Send Byte	15h	Stores the user OTP section
0x22C	RESTORE_USER_ALL	Send Byte	16h	Reloads the user OTP section
0x232	CAPABILITY	Read Byte	19h	Returns 1010xxxx to indicate Packet Error Checking is supported and Maximum bus speed is 400kHz
0x236	SMBALERT_MASK	Block Write/ Block Read Process Call	1Bh	Set to prevent warning or fault conditions from asserting the SMBALERT# signal. Write command code for STATUS register

Fault Communication

I2C Register Address	COMMAND	PMBus PROTOCOL	PMBus COMMAND CODE	DESCRIPTION
				to be masked in the low byte, the bit to be masked in the High byte.
0x240	VOUT_MODE	Read/Write Byte	20h	Sets the format for VOUT related commands. Linear mode, -8, -9, and -12 exponents supported.
0x242	VOUT_COMMAND	Read/Write Word	21h	Sets the voltage to which the device should set the output. Format according to VOUT_MODE. Resolution is 5mV when the IC Vout is configured with a load line. Resolution is 5mV or 0.625 mV when the IC is configured without a load line.
0x248	VOUT_MAX	Read/Write Word	24h	Sets an upper limit on the output voltage the unit can command. Format according to VOUT_MODE.
0x24A	VOUT_MARGIN_HIGH	Read/Write Word	25h	Sets the margin high voltage when commanded by OPERATION. Must be in format determined by VOUT_MODE.
0x24C	VOUT_MARGIN_LOW	Read/Write Word	26h	Sets the margin low voltage when commanded by OPERATION. Must be in format determined by VOUT_MODE.
0x24E	VOUT_TRANSITION_RATE	Read/Write Word	27h	Sets the rate at which the output changes voltage due to VOUT_COMMAND or OPERATION commands.
0x250	VOUT_DROOP	Read/Write Word	28h	Allows the user to set the load-line value in resolution of 5/256 Ω . Exponent is 1
0x252	VOUT_SCALE_LOOP	Read/Write Word	29h	Used to account for any external attenuation network on VOUT sense feedback and provide correct VOUT reporting.
0x256	VOUT_MIN	Read/Write Word	2Bh	Sets a lower limit on the commanded output voltage. Format according to VOUT_MODE
0x266	FREQUENCY_SWITCH	Read/Write Word	33h	Sets the switching frequency in kHz per table found in user note UN0047. Exp = 0, 1
0x26A	VIN_ON	Read/Write Word	35h	Sets the value of the input voltage at which the unit should begin power conversion. Exp = -1.
0x26C	VIN_OFF	Read/Write Word	36h	Sets the value of the input voltage at which the unit, once operation has started, should stop power conversion. Exp = -1.
0x270	IOUT_CAL_GAIN	Read/Write Word	38h	Used to calibrate the output current's gain
0x272	IOUT_CAL_OFFSET	Read/Write Word	39h	Used to null out any offsets in the output current sensing circuitry. Exp = 2.

Fault Communication

I2C Register Address	COMMAND	PMBus PROTOCOL	PMBus COMMAND CODE	DESCRIPTION
0x280	VOUT_OV_FAULT_LIMIT	Read Only	40h	Returns the value of the output voltage, measured at the sense or output pins, that causes an output over voltage fault.
0x282	VOUT_OV_FAULT_RESPONSE	Read/Write Byte	41h	Instructs the device on what action to take in response to an output over voltage fault. Only shutdown and ignore are supported.
0x288	VOUT_UV_FAULT_LIMIT	Read Only	44h	Returns the value of the output voltage, measured at the sense or output pins, that causes an output undervoltage fault.
0x28A	VOUT_UV_FAULT_RESPONSE	Read/Write Byte	45h	Instructs the device on what action to take in response to an output undervoltage fault. Only shutdown and ignore are supported.
0x28C	IOUT_OC_FAULT_LIMIT	Read/Write Word	46h	Sets the value of the output current, in amperes, that causes the over current detector to indicate an over current fault condition. Set by writing this command in Linear format with a -1 exponent.
0x28E	IOUT_OC_FAULT_RESPONSE	Read/Write Byte	47h	Instructs the device on what action to take in response to an output over current fault. Only C0h (shutdown immediately), F8h (hiccup forever), and D8 (hiccup 3 times) are supported.
0x29E	OT_FAULT_LIMIT	Read/Write Word	4Fh	Sets the temperature, in degrees Celsius, of the unit at which it should indicate an over temperature fault. Exp = 0.
0x2A0	OT_FAULT_RESPONSE	Read/Write Byte	50h	Instructs the device on what action to take in response to an over temperature fault. Only shutdown and ignore are supported.
0x2A2	OT_WARN_LIMIT	Read/Write Word	51h	Sets the temperature, in degrees Celsius, of the unit at which it should indicate an over temperature Warning alarm. Exp = 0.
0x2AA	VIN_OV_FAULT_LIMIT	Read/Write Word	55h	Sets the value of the input voltage that causes an input over voltage fault. Exp = -4.
0x2AC	VIN_OV_FAULT_RESPONSE	Read/Write Byte	56h	Instructs the device on what action to take in response to an input over voltage fault. Only shutdown and ignore are supported.
0x2BC	POWER_GOOD_ON	Read/Write Word	5Eh	Sets the output voltage at which an optional POWER_GOOD signal should be asserted. Format according to VOUT_MODE.
0x2BE	POWER_GOOD_OFF	Read/Write Word	5Fh	Sets the output voltage at which an optional POWER_GOOD signal should be

Fault Communication

I2C Register Address	COMMAND	PMBus PROTOCOL	PMBus COMMAND CODE	DESCRIPTION
				negated. Format according to VOUT_MODE.
0x2C0	TON_DELAY	Read/Write Word	60h	Sets the time, in milliseconds, from when a start condition is received (as programmed by the ON_OFF_CONFIG command) until the output voltage starts to rise. Exp = 0.
0x2C2	TON_RISE	Read/Write Word	61h	Sets the time, in milliseconds, from when the output starts to rise until the voltage has entered the regulation band. Exp = 0.
0x2C8	TOFF_DELAY	Read/Write Word	64h	Sets the time (in ms) from when a stop condition is received (as programmed by the ON_OFF_CONFIG command) until the unit stops transferring energy to the output. Exp = 0.
0x2CA	TOFF_FALL	Read/Write Word	65h	Sets the time, in milliseconds, from the end of the turn-off delay time until the voltage is commanded to zero. Exp = 0.
0x2F0	STATUS_BYTE	Read/Write Byte	78h	Returns 1 byte where the bit meanings are: Bit <7> Reserved Bit <6> Output off (due to fault or enable) Bit <5> Output over voltage fault Bit <4> Output over current fault Bit <3> Input under voltage fault Bit <2> Temperature fault Bit <1> Communication/Memory/Logic fault Bit <0>: None of the Above
0x2F2	STATUS_WORD	Read/Write Word	79h	Returns 2 bytes where the Low byte is the same as the STATUS_BYTE data. The High byte has bit meanings are: Bit <7> Output high or low fault Bit <6> Output over current fault Bit <5> Input voltage or current fault. Bit <4> MFR_SPECIFIC Bit <3> POWR GOOD# Bit <2:0> Not Supported
0x2F4	STATUS_VOUT	Read/Write Byte	7Ah	Bit <7> Output over voltage Fault Bit <6> Not Supported Bit <5> Not Supported Bit <4> Output Undervoltage Fault Bit <3> VOUT_MAX Warning Bit <2:0> Not Supported

Fault Communication

I2C Register Address	COMMAND	PMBus PROTOCOL	PMBus COMMAND CODE	DESCRIPTION
0x2F6	STATUS_IOUT	Read/Write Byte	7Bh	Bit <7> Output over current Fault Bit <6> Not Supported Bit <5> Output over current Warning Bit <4:0> Not Supported
0x2F8	STATUS_INPUT	Read/Write Byte	7Ch	Bit <7> Input over voltage Fault Bit <6:0> Not Supported
0x2FA	STATUS_TEMPERATURE	Read/Write Byte	7Dh	Bit <7> Over temperature Fault Bit <6> Over temperature Warning Bit <5:0> Reserved
0x2FC	STATUS_CML	Read/Write Byte	7Eh	Returns 1 byte where the bit meanings are: Bit <7> Invalid or unsupported command Bit <6> Invalid or unsupported data Bit <5> PEC fault Bit <4:2> Reserved Bit <1> Other communication fault not listed here Bit <0> Reserved
0x310	READ_VIN	Read Word	88h	Returns the input voltage in Volts
0x312	READ_IIN	Read Word	89h	Returns the input current in Amperes
0x316	READ_VOUT	Read Word	8Bh	Returns the output voltage in the format set by VOUT_MODE
0x318	READ_IOUT	Read Word	8Ch	Returns the output current in Amperes
0x31A	READ_TEMPERATURE_1	Read Word	8Dh	Returns the addressed loop NTC temperature in degrees Celsius
0x32C	READ_POUT	Read Word	96h	Returns the output power in Watts
0x32E	READ_PIN	Read Word	97h	Returns the input power in Watts
0x330	PMBUS_REVISION	Read Byte	98h	Reports PMBus Part I rev 1.1 & PMBus Part II rev 1.2(draft)
0x332	MFR_ID	Block Read/Write Byte count = 2	99h	The MFR_ID is set to IR (ASCII 52 49) unless programmed differently in the USER registers of the controller.
0x334	MFR_MODEL	Block Read, Byte count = 1	9Ah	The MFR_MODEL is the same as the device ID if the USER register for Manufacturer model is 00. Otherwise MFR_Model command returns the value in the USER register for MFR_MODEL.
0x336	MFR_REVISION	Block Read, Byte count = 2	9Bh	The MFR_REVISION is the same as the device revision if the USER register for Manufacturer revision is 00. Otherwise MFR_REVISION command returns the value in the USER register for MFR_REVISION.
0x35A	IC_DEVICE_ID	Block Read	ADh	Returns a 1-byte code with the following values: 5Dh = TDA38640

Fault Communication

I2C Register Address	COMMAND	PMBus PROTOCOL	PMBus COMMAND CODE	DESCRIPTION
0x35C	IC_DEVICE_REV	Block Read	AEh	The IC revision that is stored inside the IC
0x382	MFR_VENDOR_INFO_1	Block Read, Byte count = 2	C1h	Returns the product_id and silicon revision
0x384	MFR_VENDOR_INFO_2	Block Read/Write Byte count = 2	C2h	Available for vendor use
0x3A0	MFR_READ/WRITE_REG	Custom MFR protocol	D0h	Read/Write I2C registers

15.5 11-BIT Linear Data Format

Monitored parameters use the Linear Data Format (Figure 24) encoding into 1 Word (2 bytes), where:

$$Value = Y * 2^N$$

Note N and Y are “signed” values. If VOUT is set to linear format (by VOUT_MODE), then N is set by the VOUT_MODE command and only Y is returned in the data-field as a 16-bit unsigned number.

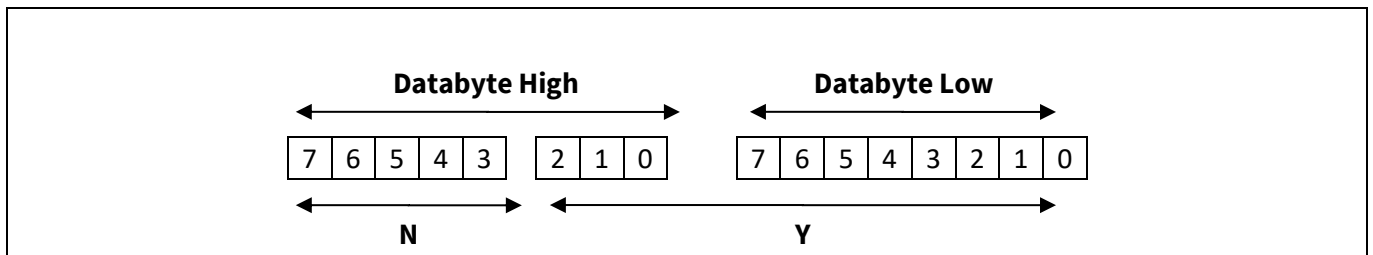

Figure 24 11-Bit Linear Data Format

15.6 16-BIT Linear Data Format

This format is only used for VOUT related commands (READ_VOUT, VOUT_COMMAND, VOUT_MARGIN_HIGH, VOUT_MARGIN_LOW, POWER_GOOD_ON, and POWER_GOOD_LOW):

$$Value = Y * 2^N$$

Note N and Y are “signed” values. If VOUT is set to linear format (by VOUT_MODE), then N is set by the VOUT_MODE command and only Y is returned in the data-field as a 16-bit unsigned number.

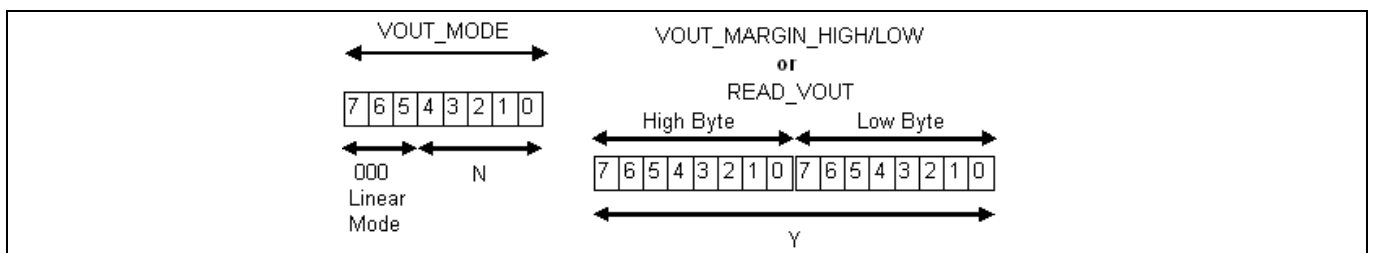

Figure 25 16-BIT Linear Data Format

Fault Communication

15.7 SVID Registers

A list of all the SVID registers is given in Table 21. SVID registers supported by the TDA38640 in VR12.5, VR13, and VR13.HC mode conform to VR12.5, VR13, and VR13.HC specifications respectively.

Table 21 SVID Registers

Register Address	Register Name	Access	VR12.5 Mode	VR13 Mode	VR14 Mode
00	Vendor ID	RO	Supported	Supported	Supported
01	Product ID	RO	Supported	Supported	Supported
02	Product Revision	RO	Supported	Supported	Supported
03	Product Date Code	-	Not Supported	Not Supported	Not Supported
04	Lot Code	-	Not Supported	Not Supported	Not Supported
05	Protocol ID	RO	Supported	Supported	Supported
06	Capability	RO	Supported	Supported	Supported
07	Step Size	RO	Not Supported	Not Supported	Not Supported
07	Vendor Use	RW	Not Supported	Not Supported	Not Supported
08	Bias VID Table	RO	Not Supported	Not Supported	Not Supported
09	VIDOMAX_H_CAPA	RO	Not Supported	Not Supported	Supported
0A	VIDOMAX_L	RO	Not Supported	Not Supported	Supported
0B	VIN_FULLSCALE_H	RO	Not Supported	Not Supported	Not Supported
0C	VIN_FULLSCALE_L	RO	Not Supported	Not Supported	Not Supported
0D	VOUT_FULLSCALE_H	RO	Not Supported	Not Supported	Supported
0E	VOUT_FULLSCALE_L	RO	Not Supported	Not Supported	Supported
0F	ALLCALL_ACT	RW	Not Supported	Not Supported	Supported
10	Status_1	RO	Supported	Supported	Supported
11	Status_2	RO	Supported	Supported	Supported
12	Temperature	RO	Supported	Supported	
13	PMIC_GLOBAL_ST	RO	Not Supported	Not Supported	Not Supported
14	LASTREAD	RO	Not Supported	Not Supported	Supported
15	IOUT_H	RO	Supported	Supported	Supported
16	VOUT_H	RO	Supported	Supported	Supported

Fault Communication

Register Address	Register Name	Access	VR12.5 Mode	VR13 Mode	VR14 Mode
17	VR Temperature	RO	Supported	Supported	Supported
18	Output Power	RO	Supported	Supported	Supported
19	Input Current	RO	Not Supported	Not Supported	Not Supported
1A	Input Voltage	RO	Not Supported	Not Supported	Not Supported
1B	Input Power	RO	Not Supported	Not Supported	Not Supported
1C	Status 2 Last Read	RO	Supported	Supported	Supported
1D	PARERR_CNT	RO	Not Supported	Not Supported	Not Supported
1E	CFG_FILE_ID	RO	Not Supported	Not Supported	Supported
1F	Future Command	-	Not Supported	Not Supported	Not Supported
20	ICC IN Max	RO	Not Supported	Not Supported	Not Supported
21	ICC Max	RO	Supported	Supported	Supported
22	Temp Max	RO	Not Supported	Supported	Supported
23	DC_LL	RO	Not Supported	Not Supported	Not Supported
24	SR_Fast	RO	Supported	Supported	Supported
25	SR_Slow	RO	Supported	Supported	Supported
26	Vboot	RO	Supported	Supported	Supported
27	VR Tolerance	-	Not Supported	Not Supported	Not Supported
28	Current-Offset	RW	Not Supported	Not Supported	Not Supported
29	Temperature Offset	RW	Not Supported	Not Supported	Not Supported
2A	Slow Slew Rate Select	RW	Not Supported	Supported	Supported
2B	PS4 Exit Latency	RO	Not Supported	Not Supported	Supported
2C	PS3 Exit Latency	RO	Not Supported	Not Supported	Supported
2D	Enable to Ready	RO	Not Supported	Not Supported	Supported
2E	Pin Max	RO	Not Supported	Not Supported	Not Supported
2F	Pin Alert Threshold	RW	Not Supported	Not Supported	Not Supported

Fault Communication

Register Address	Register Name	Access	VR12.5 Mode	VR13 Mode	VR14 Mode
30	V _{OUT} Max	RW	Supported	Supported	Supported
31	VID Setting	RW	Supported	Supported	Supported
32	Pwr State	RW	Supported	Supported	Supported
33	Offset	RW	Supported	Supported	Supported
34	Multi VR Config	RW	Supported	Supported	Supported
35	MAIN_ADDR_PTR	RW	Not Supported	Not Supported	Not Supported
36	DC_LL_FINE	RO	Not Supported	Not Supported	Not Supported
37	Future Command	-	Not Supported	Not Supported	Not Supported
38	Future Command	-	Not Supported	Not Supported	Not Supported
39	Future Command	-	Not Supported	Not Supported	Not Supported
3A	Work Point 0	RW	Not Supported	Supported	Supported
3B	Work Point 1	RW	Not Supported	Supported	Supported
3C	Work Point 2	RW	Not Supported	Supported	Supported
3D	Work Point 3	RW	Not Supported	Supported	Supported
3E	Work Point 4	RW	Not Supported	Not Supported	Not Supported
3F	Work Point 5	RW	Not Supported	Not Supported	Not Supported
40	Work Point 6	RW	Not Supported	Not Supported	Not Supported
41	Work Point 7	RW	Not Supported	Not Supported	Not Supported
42	IVID1-VID	RW	Not Supported	Not Supported	Not Supported
43	IVID1-I	RW	Not Supported	Not Supported	Not Supported
44	IVID2-VID	RW	Not Supported	Not Supported	Not Supported
45	IVID2-I	RW	Not Supported	Not Supported	Not Supported
46	IVID3-VID	RW	Not Supported	Not Supported	Not Supported
47	IVID3-I	RW	Not Supported	Not Supported	Not Supported

Fault Communication

Register Address	Register Name	Access	VR12.5 Mode	VR13 Mode	VR14 Mode
50	HIGH_PWR	RO	Not Supported	Not Supported	Supported
51	PWRSTATE_SUP	RO	Not Supported	Not Supported	Supported
52	PHSHED_SUP	RO	Not Supported	Not Supported	Supported
53	PHSHED_ACT	RW	Not Supported	Not Supported	Supported
54	NEGVREN_SUP	RO	Not Supported	Not Supported	Supported
55	NEGVREN_ACT	RW	Not Supported	Not Supported	Supported
56	DIGOUT_STATUS	RO	Not Supported	Not Supported	Not Supported
57	WP_SLEW_0	RW	Not Supported	Not Supported	Supported
58	WP_SLEW_1	RW	Not Supported	Not Supported	Supported
59	WP_SLEW_2	RW	Not Supported	Not Supported	Not Supported
5A	WP_SLEW_3	RW	Not Supported	Not Supported	Not Supported
5B	WP_SLEW_TT	RW	Not Supported	Not Supported	Supported
60	CAL_CAPABILITY	RO	Not Supported	Not Supported	Not Supported
61	CAL_REQUEST	WT	Not Supported	Not Supported	Not Supported
62	CAL_IMAG_A	RW	Not Supported	Not Supported	Not Supported
63	CAL_IMAG_B	RW	Not Supported	Not Supported	Not Supported
64	CAL_STATUS	RO	Not Supported	Not Supported	Not Supported
70	EXP_ACCURACY	RO	Not Supported	Not Supported	Not Supported
71	IOUT_L	RO	Not Supported	Not Supported	Not Supported
72	VOUT_L	RO	Not Supported	Not Supported	Not Supported
73	POUT_L	RO	Not Supported	Not Supported	Not Supported
74	IIN_L	RO	Not Supported	Not Supported	Not Supported

Fault Communication

Register Address	Register Name	Access	VR12.5 Mode	VR13 Mode	VR14 Mode
75	VIN_L	RO	Not Supported	Not Supported	Not Supported
76	PIN_L	RO	Not Supported	Not Supported	Not Supported
77	PSYS_CR_LVL_L	RW	Not Supported	Not Supported	Not Supported
78	PSYS_W2_LVL_L	RW	Not Supported	Not Supported	Not Supported
79	PSYS_W1_LVL_L	RW	Not Supported	Not Supported	Not Supported
7A-BF	RESERVED		Not Supported	Not Supported	Not Supported
C0-FF	VENDOR_RESERVED	RW	Not Supported	Not Supported	Not Supported

Design example

16 Design example

In this section, an example is used to explain how to design a buck regulator with the TDA38640. The design specifications are given below.

- $PV_{in} = 12\text{ V} (\pm 10\%)$
- $V_o = 1.0\text{ V}$
- $I_o = 40\text{ A}$
- V_o ripple voltage = $\pm 1\%$ of V_o
- Load transient response = $\pm 3\%$ of V_o with a step load current = 9 A and slew rate = $30\text{ A}/\mu\text{s}$

16.1 Enabling the TDA38640

The TDA38640 has a precise Enable threshold voltage, the Enable feedback resistor, R_{EN1} and R_{EN2} , can be calculated as follows.

$$PV_{in(\min)} \times \frac{R_{EN2}}{R_{EN1} + R_{EN2}} \geq V_{EN(\max)}$$

$$R_{EN2} \geq R_{EN1} \times \frac{V_{EN(\max)}}{PV_{in(\min)} - V_{EN(\max)}}$$

Where $V_{EN(\max)}$ is the maximum spec of the EN-start-threshold as defined in the Absolute Maximum Ratings table. For $PV_{in(\min)} = 10.8\text{ V}$, select $R_{EN1} = 49.9\text{ k}\Omega$ and $R_{EN2} > 3.4\text{ k}\Omega$. Suggested value is $R_{EN2} = 7.5\text{ k}\Omega$.

16.2 Programming the Switching Frequency and Operation Mode

The TDA38640 has very good efficiency performance and is suitable for high switching frequency operation. In this case, 800 kHz is selected to achieve a good compromise between efficiency, passive component size and dynamic response. In addition, FCCM operation is selected to ensure a small output ripple voltage over the entire load range. 800 kHz switching frequency and FCCM operation can be selected via register bits.

16.3 Selecting Input Capacitors

Without input capacitors, the pulse current of Control MOSFET is provided directly from the input supply power. Due to the impedance on the cable, the pulse current can cause disturbance on the input voltage and cause potential EMI issues. The input capacitors filter the pulse current, resulting in almost constant current from the input supply. The input capacitors should be selected to tolerate the input pulse current, and to reduce the input voltage ripple. The RMS value of the input ripple current can be expressed by:

$$I_{RMS} = I_o \times \sqrt{D \times (1 - D)}$$

$$D = \frac{V_o}{PV_{in}}$$

Where I_{RMS} is the RMS value of the input capacitor current. I_o is the output current and D is the Duty Cycle. For $I_o = 40\text{ A}$ and $D_{(\max)} = 0.09$, the resulting RMS current flowing into the input capacitor is $I_{rms} = 11.6\text{ A}$.

To meet the requirement of the input ripple voltage, the minimum input capacitance can be calculated as follows.

$$C_{in(\min)} > \frac{I_o \times (1 - D) \times D}{f_{sw} \times (\Delta PV_{in} - ESR \times I_o \times (1 - D))}$$

Design example

Where ΔPV_{in} is the maximum allowable peak-to-peak input ripple voltage, and ESR is the equivalent series resistance of the input capacitors. Ceramic capacitors are recommended due to low ESR, ESL and high RMS current capability. For $I_o = 40$ A, $f_{sw} = 800$ kHz, $ESR = 3$ m Ω , and $\Delta PV_{in} = 240$ mV, $C_{in(min)} > 32$ μ F. To account for the derating of ceramic capacitors under a bias voltage, 10×22 μ F/0805/25 V MLCC are used for the input capacitors. In addition, a bulk capacitor is recommended if the input supply is not located close to the voltage regulator.

16.4 Inductor Selection

The inductor is selected based on output power, operating frequency and efficiency requirements. A low inductor value results in a large ripple current, lower efficiency and high output noise, but helps with size reduction and transient load response. Generally, the desired peak-to-peak ripple current in the inductor (Δi) is found between 20% and 50% of the output current.

The inductor saturation current must be higher than the maximum spec of the OCP limit plus the peak-to-peak inductor ripple current. For some core material, inductor saturation current may decrease with an increase in temperature. It is important to check the inductor saturation current at the maximum operating temperature.

The inductor value for the desired operating ripple current can be determined using the following relation:

$$L = (PV_{in(max)} - V_o) \times \frac{D_{min}}{\Delta i_{L(max)} \times F_{sw}}$$

$$D_{min} = \frac{V_o}{PV_{in(max)}}$$

$$I_{sat} \geq OCP_{max} + \Delta i_{L(max)}$$

Where: $PV_{in(max)}$ = Maximum input voltage; $\Delta i_{L(max)}$ = Maximum peak-to-peak inductor ripple current; OCP_{max} = maximum spec of the OCP limit as defined in Section 14.1, and I_{sat} = inductor saturation current. In this case, select inductor $L = 150$ nH to achieve $\Delta i_{L(max)} = 25\%$ of $I_{o(max)}$. The I_{sat} should be no less than 56 A.

16.5 Output Capacitor Selection

The output capacitor selection is mainly determined by the output voltage ripple and transient requirements.

To satisfy the V_o ripple requirement, C_o should satisfy the following criterion.

$$C_o > \frac{\Delta i_{Lmax}}{8 \times \Delta V_{or} \times f_{sw}}$$

Where ΔV_{or} is the desired peak-to-peak output ripple voltage. For $\Delta i_{L(max)} = 7.5$ A, $\Delta V_{or} = 20$ mV, $f_{sw} = 800$ kHz, C_o must be larger than 59 μ F. The ESR and ESL of the output capacitors, as well as the parasitic resistance or inductance due to PCB layout, can also contribute to the output voltage ripple. It is suggested to use Multi-Layer Ceramic Capacitor (MLCC) for their low ESR, ESL and small size.

To meet the transient response requirements, the output capacitors should also meet the following criterion.

$$C_o > \frac{L \times \Delta I_{o(max)}^2}{2 \times \Delta V_{oL} \times V_o}$$

Where ΔV_{oL} is the allowable V_o deviation during the load transient. $\Delta I_{o(max)}$ is the maximum step load current. Please note that the impact of ESL, ESR, control loop response, transient load slew rate, and PWM latency is not considered in the calculation shown above. Extra capacitance is usually needed to meet the transient requirements. As a rule of thumb, we can triple the C_o that is calculated above as a starting point, and then optimize the design based on the bench measurement. In this case, to meet the transient load requirement (i.e. $\Delta V_{oL} = 30$ mV, $\Delta I_{o(max)} = 9$ A), select $C_o = \sim 600$ μ F. For more accurate estimation of C_o , simulation tool should be used to aid the design.

Design example**16.6 Output Voltage Programming**

Output voltage can be programmed with register bits and modified with PMBus or SVID commands, depending on chosen operating mode.

16.7 Bootstrap Capacitor

For most applications, a 0.1 μF ceramic capacitor is recommended for the bootstrap capacitor placed between PHASE and BOOT. For applications requiring PV_{in} equal to or above 14 V, a small resistor of 1 - 2 Ω should be used in series with the BOOT pin to ensure the maximum SW node spike voltage does not exceed 20 V.

16.8 PVIN, and VCC/LDO bypass Capacitor

Please see the recommendation in 13.4 on the internal LDO. A 10 μF MLCC is selected for the VCC/LDO bypass capacitor and a 4.7 μF MLCC is selected for the PVIN bypass capacitor.

16.9 Design Recommendations

Listed below are the design recommendations for an application utilizing TDA38640.

- A 0 Ω resistor should be connected between Vcc and Vdrv
- A 100 Ω minimum load resistor should be connected across the output
- The GL pin should be floating. It is available for testing purpose only
- Pin 19 should be grounded
- AGND and PGND should be shorted with minimum possible impedance
- Add a 1 μF or a 2.2 μF 0402 ceramic cap across PVIN and PGND for high frequency decoupling
- Add a 1 μF or a 2.2 μF 0402 ceramic cap across PVIN and PGND for high frequency decoupling
- Check the sequence of PreBias, PVIN, VCC/VDRV and EN to meet the recommended sequence
- Check for proper selection of remote and local sense resistors.
- The LDO output should not be used to power external devices

17 Layout Recommendations

PCB layout is very important when designing high frequency switching converters. Layout will affect noise pickup and can cause a good design to perform with less than expected results. Following design guidelines are recommended to achieve the best performance.

- Bypass capacitors, including input/output capacitors V_{CC}/V_{DRV} bypass capacitors, should be placed near the corresponding pins as close as possible.
- Place bypass capacitors from TDA38640 power input (Drain of Control MOSFET) to PGND (Source of Synchronous MOSFET) to reduce noise and ringing in the system. The output capacitors should be terminated to a ground plane that is away from the input PGND to mitigate the switching spikes on the V_o . The bypass capacitor shared by VCC and VDRV should be terminated to PGND.
- Place a boot strap capacitor near the TDA38640 BOOT and PHASE pin as close as possible to minimize the loop inductance.
- SW node copper should only be routed on the top layer to minimize the impact of switching noises
- On the TDA38640 demo board, AGND pin is connected to the exposed PGND pad with a copper trace.
- Via holes can be placed on P_{Vin} and PGND pads to aid thermal dissipation.
- Wide copper polygons are desired for P_{Vin} and PGND connections in favor of power losses reduction and thermal dissipation. Sufficient via holes should be used to connect power traces between different layers.
- Output voltage sensing in TDA38640 is done differentially using the VOSEN_P and VOSEN_M pins.
 - A pair of PCB traces with at least 15 mil trace width, running close to each other and away from any noise sources such as inductor and SW nodes, should be used to implement Kelvin sensing of the voltage across a high-frequency bypass capacitor of 0.1 μ F or higher.
 - The ground connection of the remote sensing signal must be terminated at VOSEN_M pin.
 - The V_o connection of the remote sensing signal must be connected to the feedback resistor divider with the lower feedback resistor terminated at VOSEN_M pin for output voltages greater than 2.5 V.
 - Shield the pair of remote sensing lines with ground planes above and below
 - Do **NOT** connect VOSEN_M pin and AGND pin in this configuration
- VINSEN_M and VINSEN_P lines have to be routed differentially and they should be shielded with ground planes from above and below
- For routing the SVID lines Intel's guidance on the spacing and length of the lines allowed (maximum) should be followed. One should also pay attention to the matching resistors and the pull-up requirements when routing these lines to multiple SVID slaves. All of this information is available in the Intel VR14 PWM spec document.
- The En pin and configuration pins including SM_ADDRS/PROG should be terminated to a quiet ground. On the TDA38640 standard demo board, they are terminated to the PGND copper plane away from the power current flow. Alternatively, they can be terminated to a dedicated AGND PCB trace.

More information about the layout is found in the USER guide for the Eval Board for TDA38640. For more information on it please get in touch with the respective Sales team member

17.1 PCB Metal and Component Placement

Evaluation has shown that the best overall performance is achieved using the substrate/PCB layout as shown in the following figures. PQFN devices should be placed to an accuracy of 0.050 mm on both X and Y axes. Self-centering behavior is highly dependent on solders and processes, and experiments should be run to confirm the limits of self-centering on specific processes.

For further information, please refer to the "Recommendations for Board Assembly of Infineon Integrated Packages without Lead" Application note https://ecmpub.infineon.com/dctm-publish/ecmdata/tech_0460/Z8F80291788.pdf.

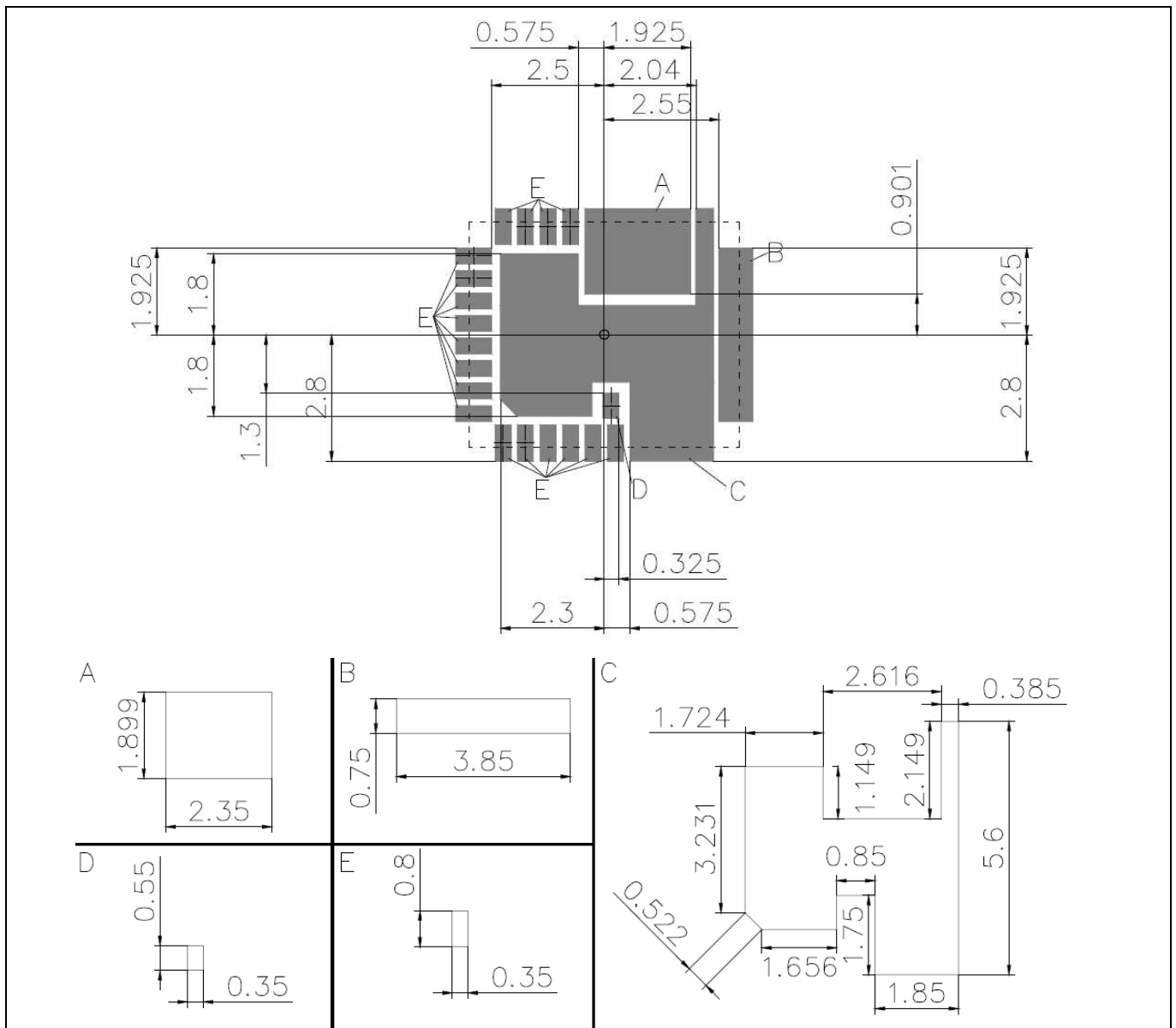

Figure 26 PCB metal pad sizing and spacing (all dimensions in mm)

17.2 Solder Resist

Infineon recommends that larger Power or Land Area pads are Solder Mask Defined (SMD.) This allows the underlying copper traces to be as large as possible, which helps in terms of current carrying capability and device cooling capability. When using SMD pads, the underlying copper traces should be at least 0.05 mm larger (on each edge) than the Solder Mask window, in order to accommodate any layer to layer misalignment. (i.e. 0.1 mm in X & Y.) When using NSMD pads, the Solder Resist Window should be larger than the Copper Pad by at least 0.025 mm on each edge, (i.e. 0.05 mm in X&Y,) in order to accommodate any layer to layer misalignment. Ensure that the solder resist in-between the smaller signal lead areas is at least 0.15 mm wide, due to the high x/y aspect ratio of the solder mask strip.

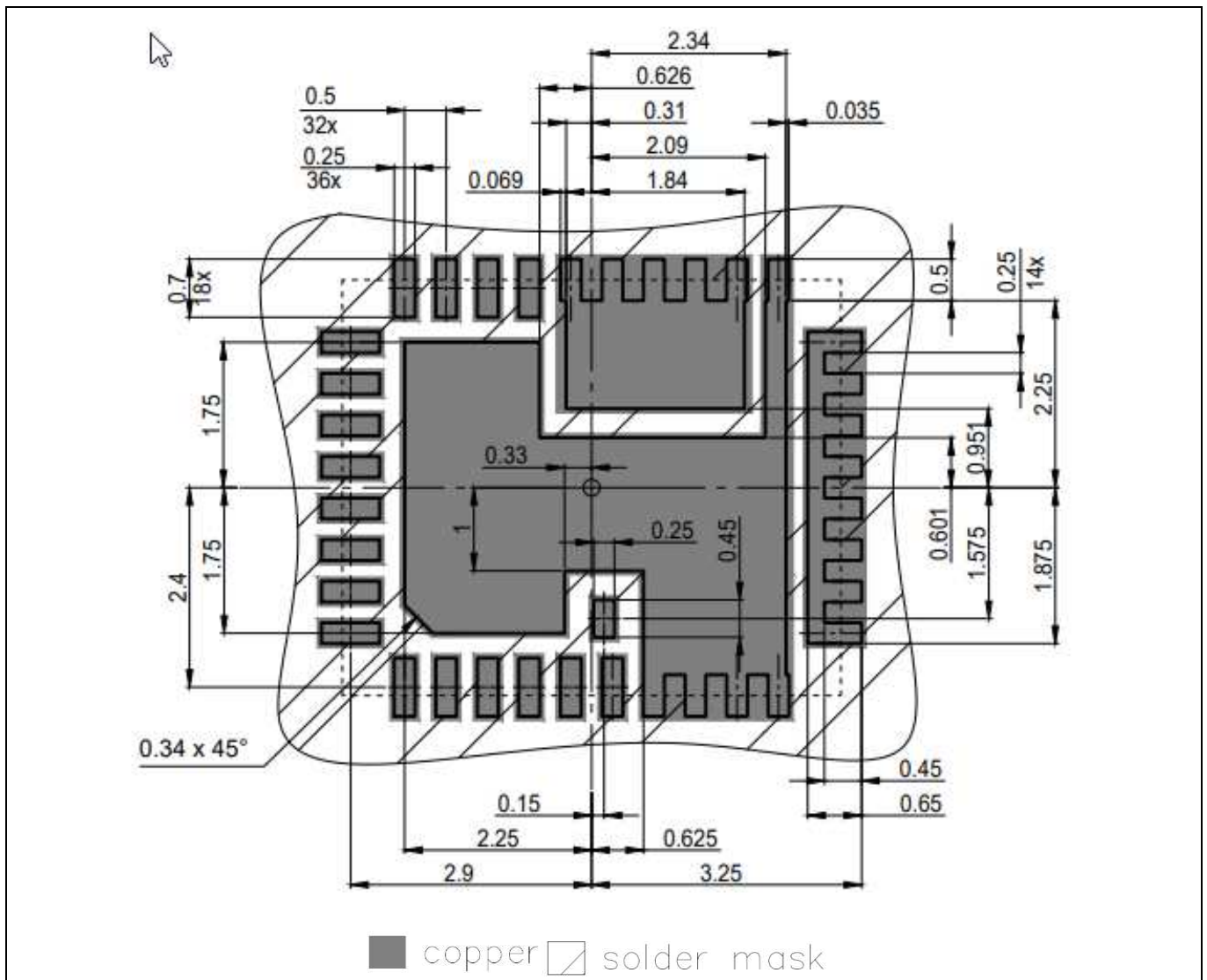

Figure 27 Solder resist

17.3 Stencil Design

Stencils for PQFN packages can be used with thicknesses of 0.100-0.250 mm (0.004-0.010”). Stencils thinner than 0.100 mm are unsuitable because they deposit insufficient solder paste to make good solder joints with the ground pad; high reductions sometimes create similar problems. Stencils in the range of 0.125 mm-0.200 mm (0.005-0.008”), with suitable reductions, give the best results.

A recommended stencil design is shown in Figure 28. This design is for a stencil thickness of 0.127 mm (0.005”). The reduction should be adjusted for stencils of other thicknesses.

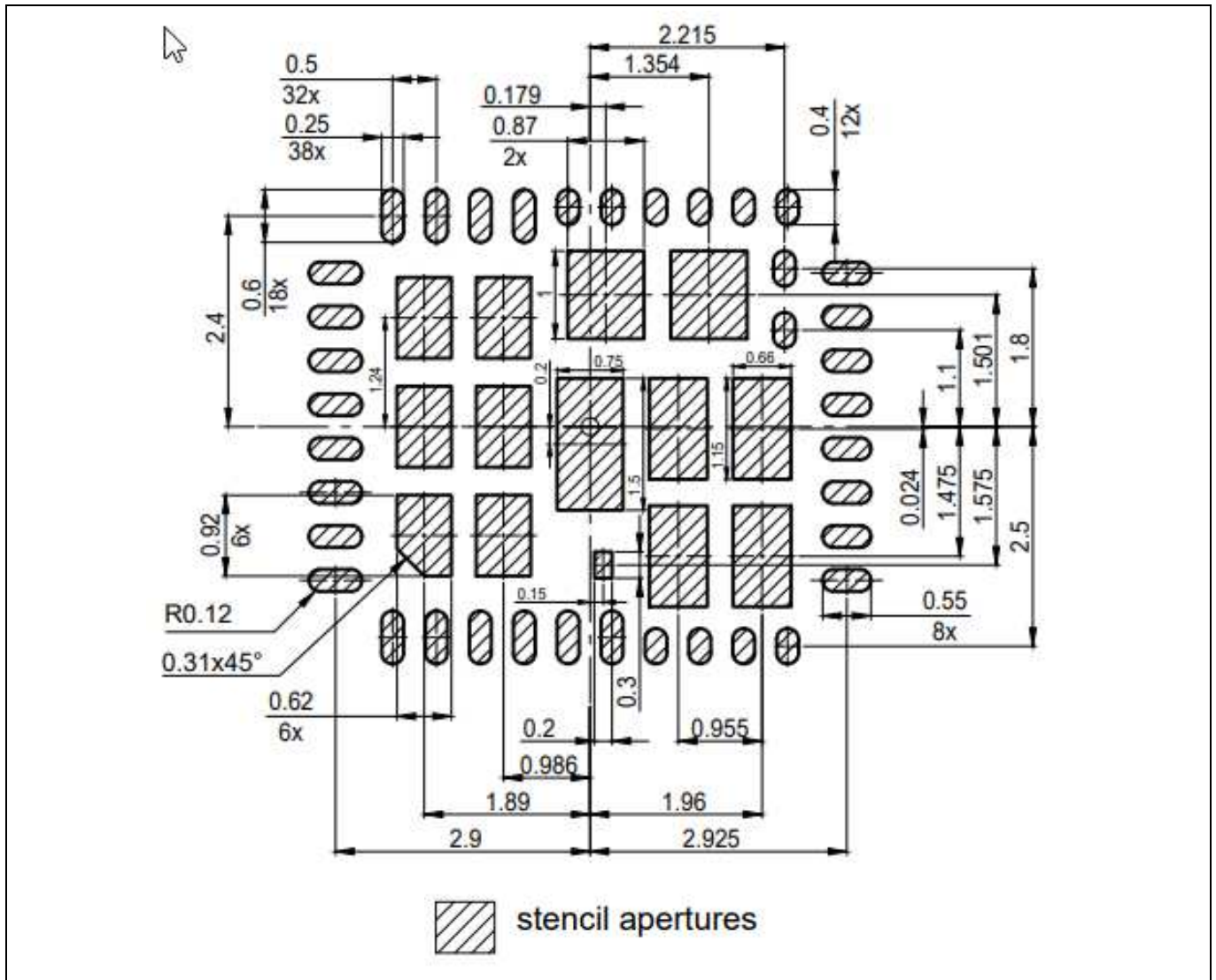

Figure 28 Stencil pad size and spacing (all dimensions in mm)

Package

18 Package

18.1 Marking Information

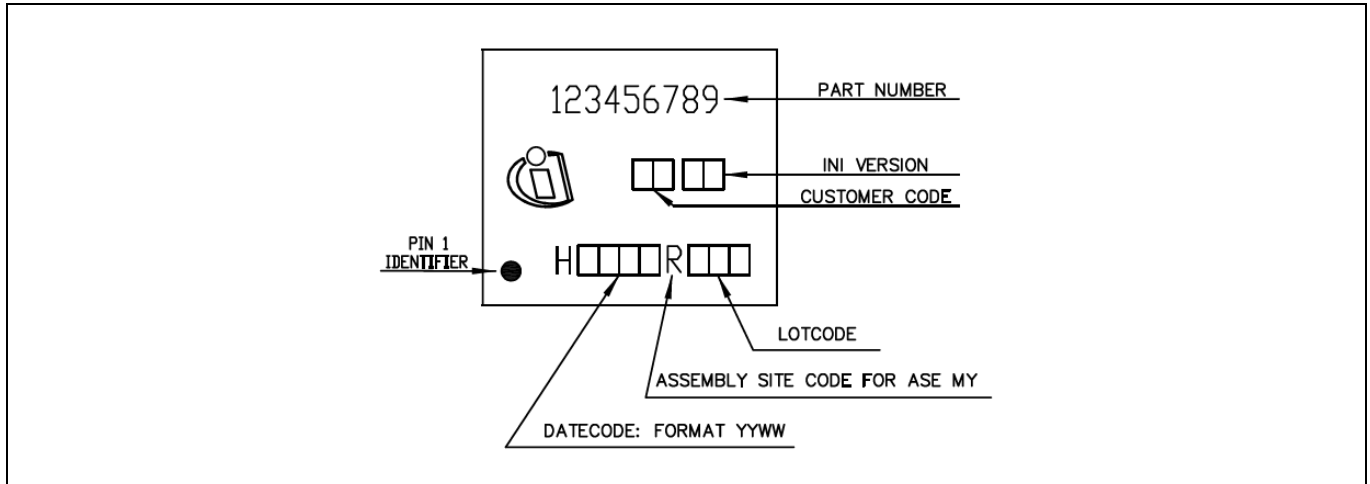

Figure 29 Package Marking

18.2 Dimensions

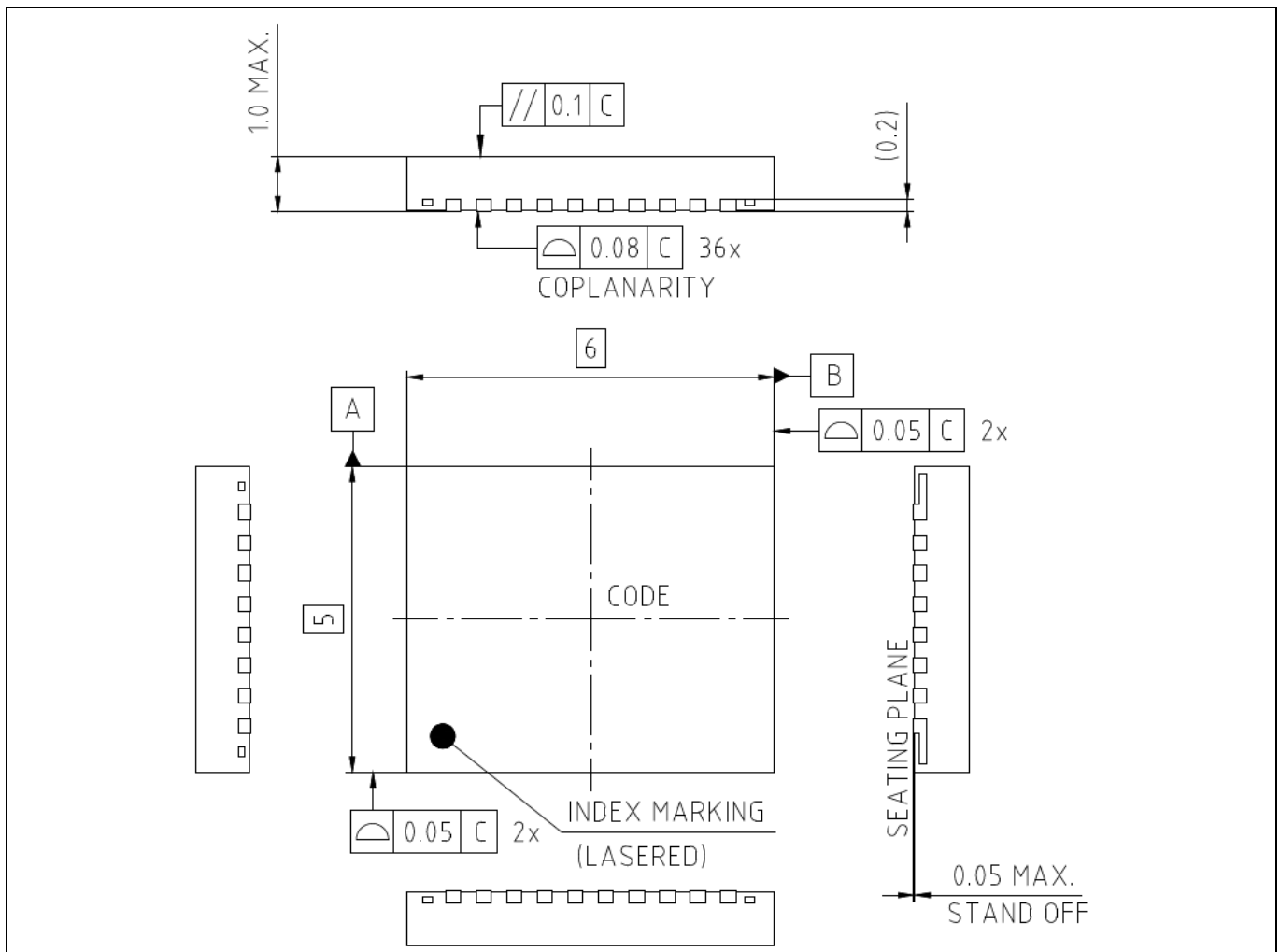

Figure 30 Package view

Package

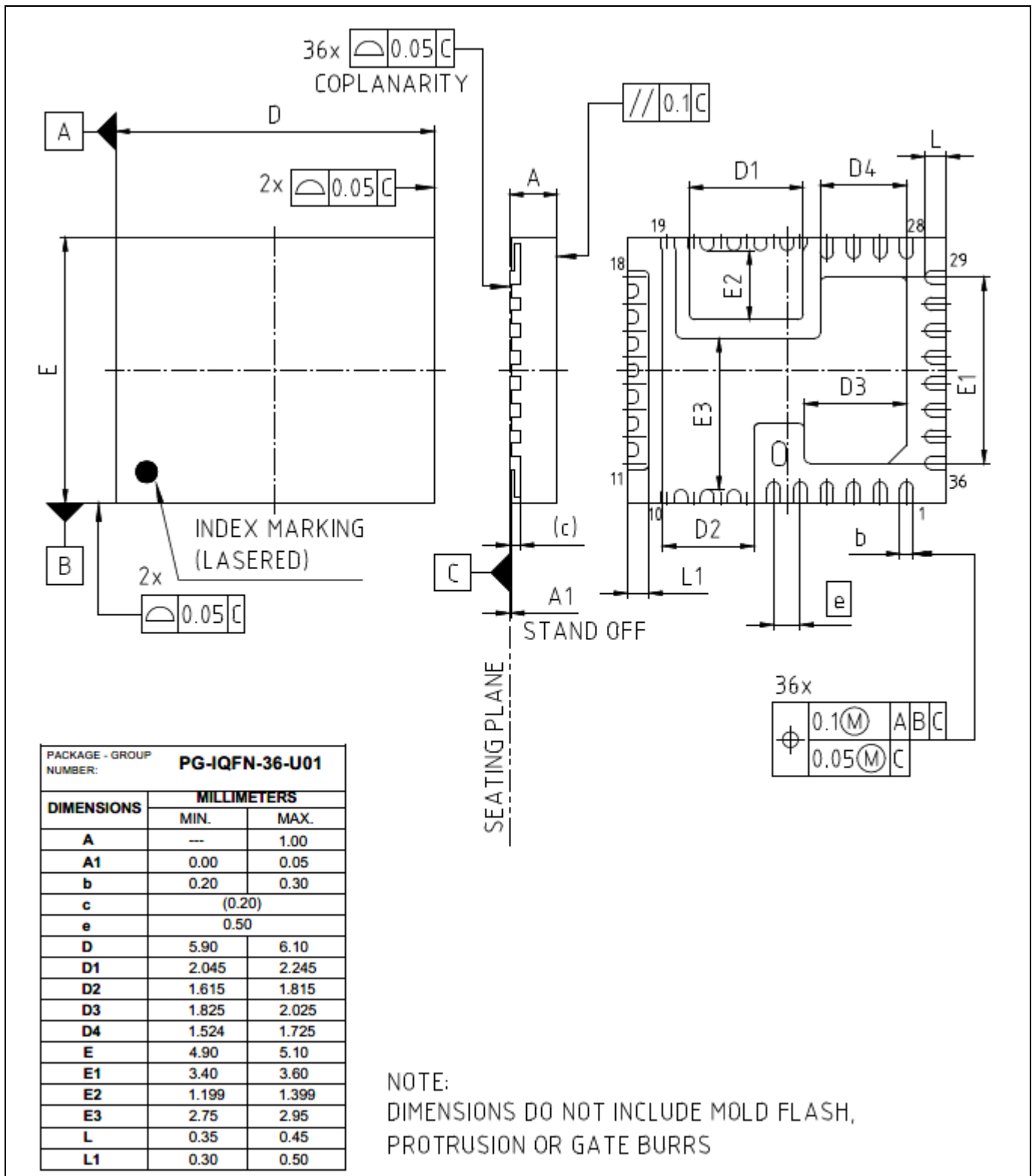

Figure 31 Package Dimensions in mm

Package

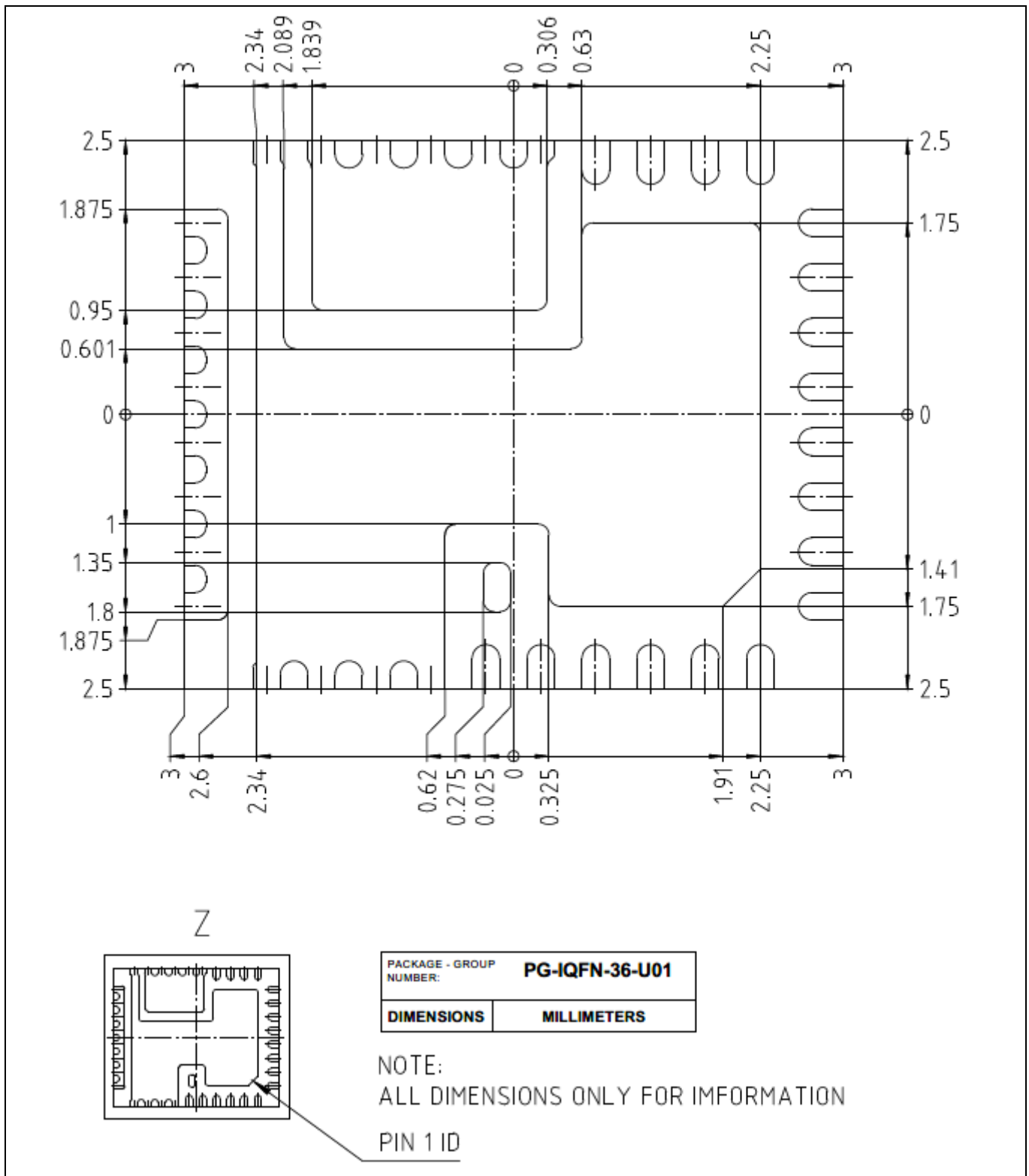

Figure 32 Package Dimensions- Pad Layout

18.3 Tape and Reel Information

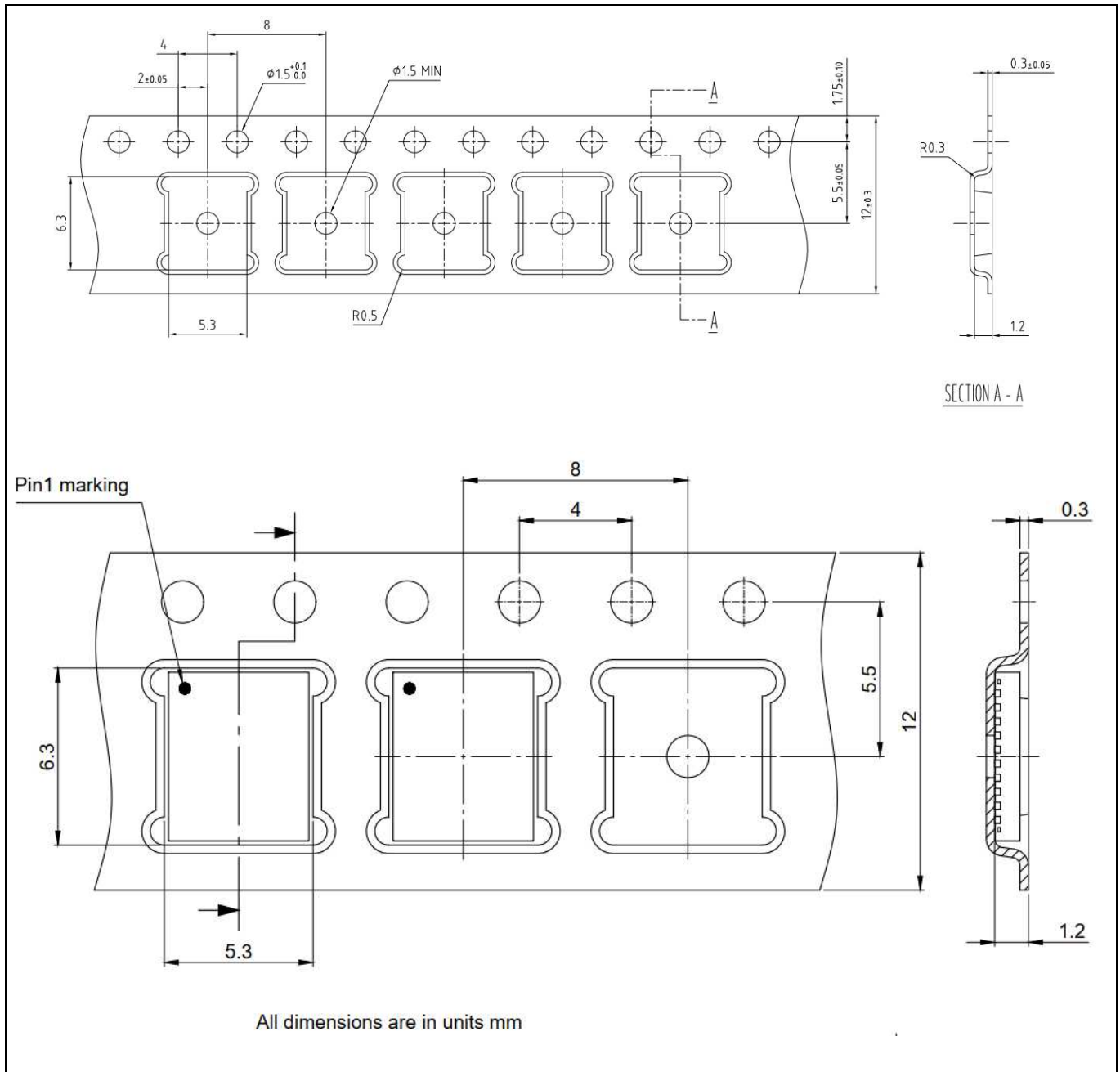

Figure 33 Pin 1 orientation in the Tape & reel

19 Environmental Qualifications

Table 22

Qualification Level		Industrial
Moisture Sensitivity		5 x 6 mm QFN Package JEDEC Level 2 @ 260°C
ESD	Human Body Model	ANSI/ESDA/JEDEC JS-001, Class 2 (2000 V to < 4000 V)
	Charged Device Model	ANSI/ESDA/JEDEC JS-002, Class C3 (≥ 1000 V)
RoHS2 Compliant		This product follows EU Directive 2015/863/EU amending Annex II to EU Directive 2011/65/EU(RoHS) and contains Pb according to RoHS exemption 7a, Lead in high melting temperature type solders

Revision History

TDA38640

Revision: 2023-10-27, Rev. 2.8

Previous Revision

Revision	Date	Subjects (major changes since last revision)
2.0	2022-04-06	Release of final version
2.1	2022-04-08	Changed the VID Setpoint Accuracy from 0.75% to 0.5% in the Electrical Specs Table
2.2	2022-04-13	No of programmable USER Images corrected from 48 to 24
2.3	2022-05-10	Corrections to the Description of LDO and Enable
2.4	2022-05-12	Correction the version number and the date of release
2.5	2022-08-12	Updated the multi-image programming capability of the device
2.6	2022-10-21	Programming Capability is re-defined, and Set-point accuracy is updated
2.7	2022-11-21	Updated the package drawing, programming Section, made changes to abs max table and Pre-bias startup section
2.8	2023-10-27	Updated the package drawings in figure 30, 31 and 32. Updated the tape and reek information in figure 33. Updated section 13.14 with correct description Updated App note reference in section 17.1

Trademarks

All referenced product or service names and trademarks are the property of their respective owners.

We Listen to Your Comments

Any information within this document that you feel is wrong, unclear or missing at all? Your feedback will help us to continuously improve the quality of this document. Please send your proposal (including a reference to this document) to:

erratum@infineon.com

Published by

Infineon Technologies AG

81726 München, Germany

© 2023 Infineon Technologies AG

All Rights Reserved.

Legal Disclaimer

The information given in this document shall in no event be regarded as a guarantee of conditions or characteristics ("Beschaffenheitsgarantie").

With respect to any examples, hints or any typical values stated herein and/or any information regarding the application of the product, Infineon Technologies hereby disclaims any and all warranties and liabilities of any kind, including without limitation warranties of non-infringement of intellectual property rights of any third party.

In addition, any information given in this document is subject to customer's compliance with its obligations stated in this document and any applicable legal requirements, norms and standards concerning customer's products and any use of the product of Infineon Technologies in customer's applications.

The data contained in this document is exclusively intended for technically trained staff. It is the responsibility of customer's technical departments to evaluate the suitability of the product for the intended application and the completeness of the product information given in this document with respect to such application.

Information

For further information on technology, delivery terms and conditions and prices please contact your nearest Infineon Technologies Office (www.infineon.com).

Warnings

Due to technical requirements, components may contain dangerous substances. For information on the types in question, please contact the nearest Infineon Technologies Office.

The Infineon Technologies component described in this Data Sheet may be used in life-support devices or systems and/or automotive, aviation and aerospace applications or systems only with the express written approval of Infineon Technologies, if a failure of such components can reasonably be expected to cause the failure of that life-support, automotive, aviation and aerospace device or system or to affect the safety or effectiveness of that device or system. Life support devices or systems are intended to be implanted in the human body or to support and/or maintain and sustain and/or protect human life. If they fail, it is reasonable to assume that the health of the user or other persons may be endangered.

Looking for pricing, stock, or lifecycle information?

Click below to explore more details on WIN SOURCE:

- ⊖ [View TDA386400000AUMA1 on WIN SOURCE](#)
- ⊖ [Infineon Technologies Information](#)

Optimize Your Supply Chain with WIN SOURCE Solutions

- ✓ Global Sourcing Solution
- ✓ Obsolete Management
- ✓ Cost Control Management
- ✓ Shortage Management
- ✓ Alternative Solution
- ✓ Excess Inventory Management