



ISL78310

High Performance 1A LDO

FN7810  
Rev 2.00  
November 7, 2014

The ISL78310 is a low dropout voltage, high-current, single output LDO specified for 1A output current. This part operates from input voltages down to 2.2V and up to 6V. The part offers fixed and external resistor adjustable output voltages from 0.8V to 5V. Custom voltage options are available upon request.

For applications that desire to set the in-rush current to less than the current limit of the part, or for applications that require turn-on time control, an external capacitor can be placed on the soft-start pin for maximum control. A supply-independent ENABLE signal allows the part to be placed into a low quiescent current shutdown mode. Sub-micron CMOS process is used for this product family to deliver best-in-class analog performance and overall value.

This CMOS LDO consumes significant lower quiescent (ground pin) current as a function of load over bipolar LDOs, which translates into higher efficiency and packages with smaller footprints. Quiescent current is optimized to achieve a very fast load transient response.

The ISL78310 is AEC-Q100 rated. The ISL78310 is rated for the automotive temperature range (-40°C to +125°C).

**Applications**

- Core & I/O power
- Camera modules
- Post regulation of switched supplies
- Radio systems
- Infotainment systems

**Features**

- 2.2V to 6V input supply
- 130mV dropout voltage typical (at 1A)
- Fast load transient response
- ±0.2% initial V<sub>OUT</sub> accuracy
- Adjustable in-rush current limiting
- 58dB typical PSRR
- 63µV<sub>RMS</sub> output noise at V<sub>OUT</sub> = 1.8V
- Power-good feature
- 500mV feedback voltage
- Supply-independent 1V enable input threshold
- Short-circuit current protection
- 1A peak reverse current
- Over-temperature shutdown
- Any cap stable with minimum 10µF ceramic
- ±1.8% guaranteed V<sub>OUT</sub> accuracy for junction temperature range from -40°C to +125°C
- Available in a 10 Lead DFN package
- Pb-free (RoHS compliant)
- AEC-Q100 qualified

**Pin Configuration**

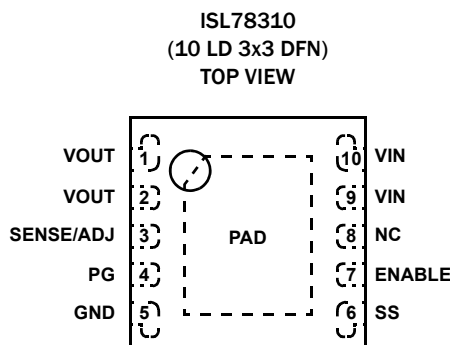

## Pin Descriptions

PIN #	PIN NAME	DESCRIPTION
1, 2	VOUT	Regulated output voltage. A minimum 10µF X5R/X7R output capacitor is required for stability. See <a href="#">"External Capacitor Requirements" on page 9</a> for more details.
3	SENSE/ADJ	For internally fixed VOUT option, this pin provides output voltage feedback. By connecting this pin to the output rail at the load, small voltage drops caused by PCB trace resistance can be eliminated. For the adjustable output voltage option, this pin is connected to the feedback resistor divider and provides voltage feedback signals for the LDO to set the output voltage.
4	PG	This is an open drain logic output used to indicate the status of the output voltage. Logic low indicates VOUT is not in regulation. Must be grounded if not used.
5	GND	Ground.
6	SS	External capacitor on this pin adjusts start-up ramp and controls in-rush current.
7	ENABLE	VIN independent chip enable. TTL and CMOS compatible.
8	NC	Do not connect this pin to ground or supply. Leave floating.
9, 10	VIN	Input supply pin. A minimum 10µF X5R/X7R input capacitor is required for stability. See <a href="#">"External Capacitor Requirements" on page 9</a> for more details.
	EPAD	EPAD at ground potential. Soldering it directly to GND plane is required for thermal considerations. See <a href="#">"Heatsinking the DFN Package" on page 12</a> for more details.

## Ordering Information

PART NUMBER (Notes 1, 3, 4)	PART MARKING	V <sub>OUT</sub> VOLTAGE (Note 2)	TEMP RANGE (°C)	PACKAGE (Pb-Free)	PKG DWG. #
ISL78310ARAJZ	DZAE	ADJ	-40 to +125	10 Ld 3x3 DFN	L10.3x3

### NOTES:

1. Add "-T\*" suffix for tape and reel. Please refer to [TB347](#) for details on reel specifications.
2. For other output voltages, contact Intersil Marketing.
3. These Intersil Pb-free plastic packaged products employ special Pb-free material sets, molding compounds/die attach materials, and 100% matte tin plate plus anneal (e3 termination finish, which is RoHS compliant and compatible with both SnPb and Pb-free soldering operations). Intersil Pb-free products are MSL classified at Pb-free peak reflow temperatures that meet or exceed the Pb-free requirements of IPC/JEDEC J STD-020.
4. For Moisture Sensitivity Level (MSL), please see device information page for [ISL78310](#). For more information on MSL please see techbrief [TB363](#).

## Typical Application Diagrams

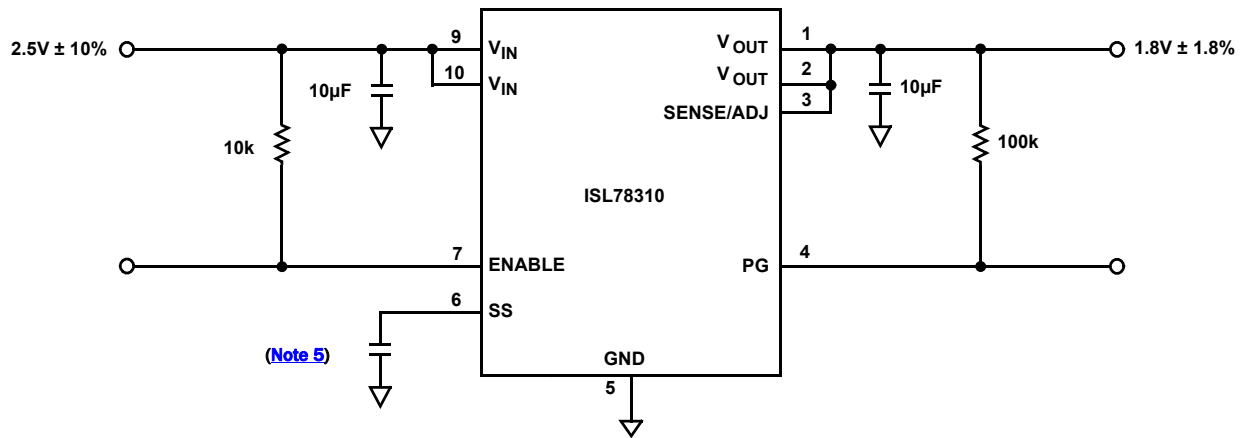

FIGURE 1. FIXED TYPICAL APPLICATION DIAGRAM

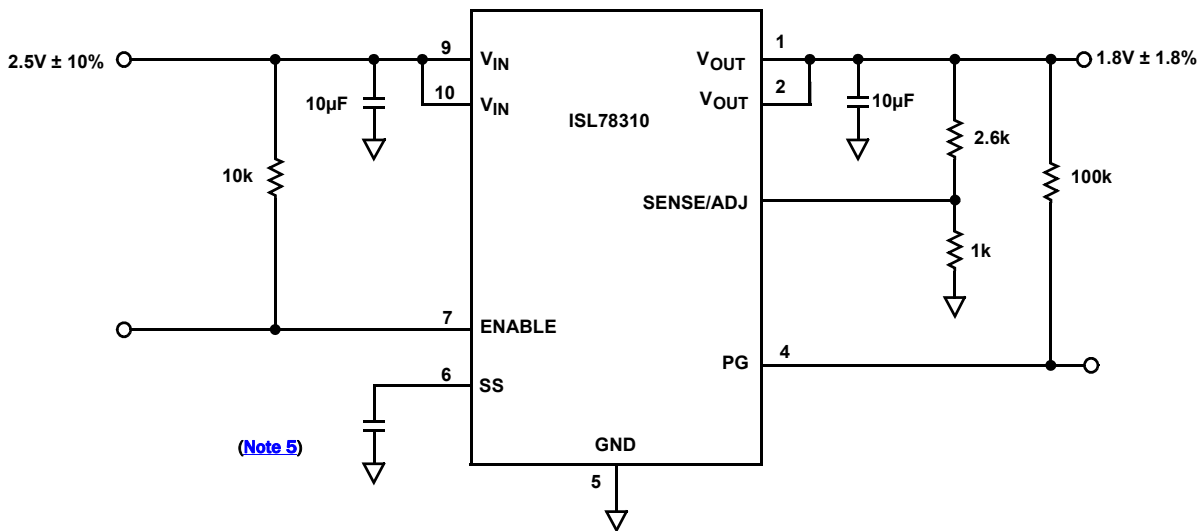
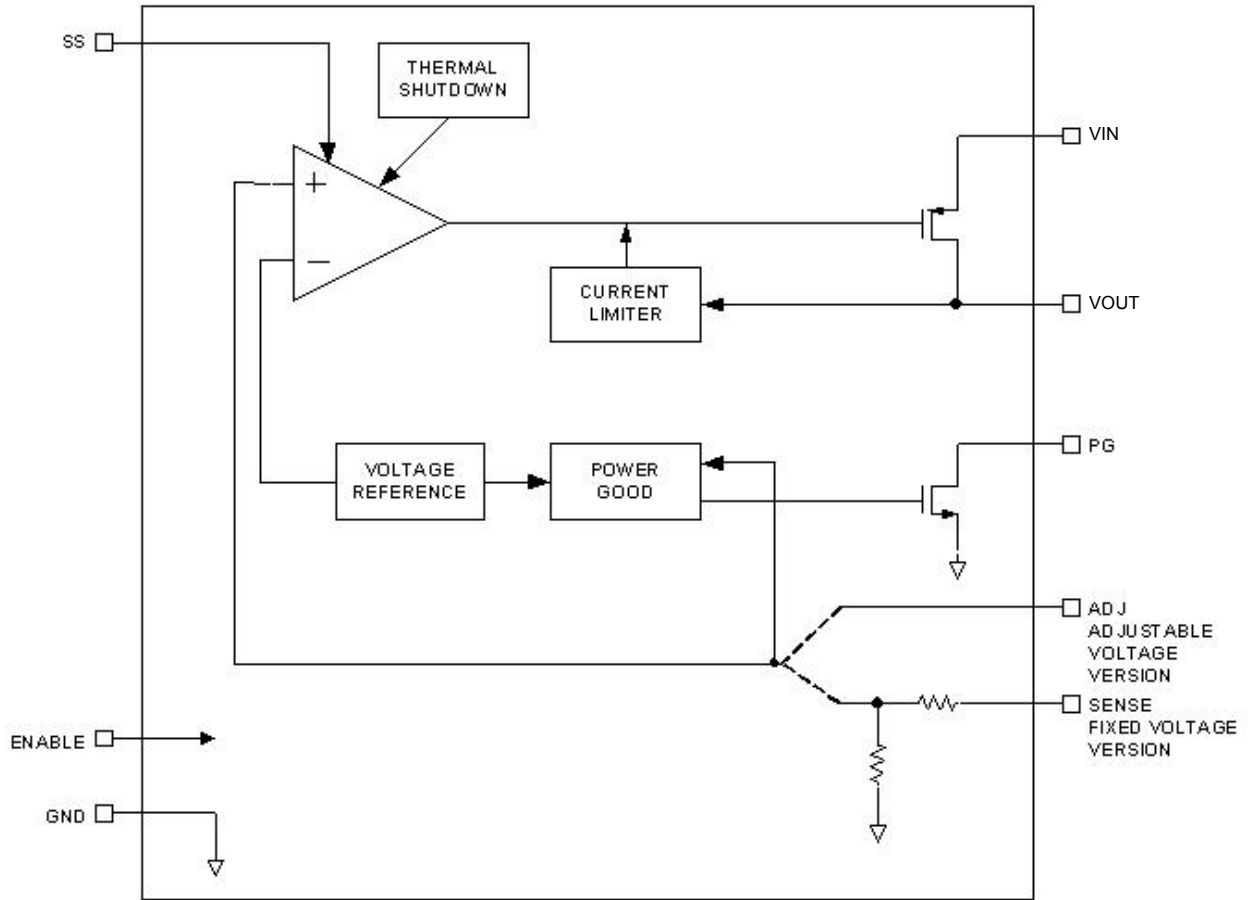

FIGURE 2. ADJUSTABLE TYPICAL APPLICATION DIAGRAM

**NOTE:**

- 5. Used when large bulk capacitance required on  $V_{OUT}$  for application.

# ISL78310 Schematic Block Diagram



## Absolute Maximum Ratings

VIN relative to GND (Note 6)	-0.3V to + 6.5V
VOUT relative to GND (Note 6)	-0.3V to + 6.5V
PG, ENABLE, SENSE/ADJ, SS	
Relative to GND (Note 6)	-0.3V to + 6.5V

## Recommended Operating Conditions (Notes 9, 10)

Junction Temperature Range (Tj) (Note 9)	-40 °C to +125 °C
VIN relative to GND	2.2V to 6V
VOUT range	800mV to 5V
PG, ENABLE, SENSE/ADJ, SS relative to GND	0V to + 6V
PG Sink Current	<10mA

## Thermal Information

Thermal Resistance	$\theta_{JA}$ (°C/W)	$\theta_{JC}$ (°C/W)
10 Ld DFN Package (Notes 7, 8)	48	7
Storage Temperature Range	-65 °C to +150 °C	
Junction Temperature	+150 °C	
Pb-Free Reflow Profile	see <a href="#">TB493</a>	

## ESD Rating

Human Body Model (Tested per JESD22-A114E)	2.5kV
Machine Model (Tested per JESD-A115-A)	250V
Charge Device Model (Tested per AEC-Q100-011)	1kV

CAUTION: Do not operate at or near the maximum ratings listed for extended periods of time. Exposure to such conditions may adversely impact product reliability and result in failures not covered by warranty.

### NOTES:

- Absolute maximum voltage rating is defined as the voltage applied for a lifetime average duty cycle above 6V of 1%.
- $\theta_{JA}$  is measured in free air with the component mounted on a high effective thermal conductivity test board with "direct attach" features. See Tech Brief [TB379](#).
- For  $\theta_{JC}$ , the "case temp" location is the center of the exposed metal pad on the package underside.
- Extended operation at these conditions may compromise reliability. Exceeding these limits will result in damage. Recommended operating conditions define limits where specifications are guaranteed.
- Electromigration specification defined as lifetime average junction temperature of +110 °C where max rated DC current = lifetime average current.

## Electrical Specifications

Unless otherwise noted,  $V_{IN} = V_{OUT} + 0.4V$ ,  $V_{OUT} = 1.8V$ ,  $C_{IN} = C_{OUT} = 10\mu F$ ,  $T_J = +25^\circ C$ ,  $I_{LOAD} = 0A$ .

Applications must follow thermal guidelines of the package to determine worst case junction temperature. Please refer to ["ISL78310 Schematic Block Diagram" on page 4](#) and Tech Brief [TB379](#). **Boldface limits apply across the operating temperature range, -40 °C to +125 °C.**

PARAMETER	SYMBOL	TEST CONDITIONS	MIN (Note 11)	TYP	MAX (Note 11)	UNITS
<b>DC CHARACTERISTICS</b>						
DC Output Voltage Accuracy	$V_{OUT}$	$V_{OUT}$ Options: 0.8V, 1.2V, 1.5V and 1.8V $2.2V \leq V_{IN} < 3.6V$ ; $0A < I_{LOAD} \leq 1A$	<b>-1.8</b>	0.2	<b>1.8</b>	%
		$V_{OUT}$ Options: 2.5V, 3.3V and 5.0V $V_{OUT} + 0.4V \leq V_{IN} \leq 6V$ ; $0A < I_{LOAD} < 1A$	<b>-1.8</b>	0.2	<b>1.8</b>	%
Feedback Pin (ADJ Option Only)	$V_{ADJ}$	$2.2V \leq V_{IN} \leq 6V$ , $0A < I_{LOAD} < 1A$	<b>491</b>	500	<b>509</b>	mV
DC Input Line Regulation	$\frac{\Delta V_{OUT}}{\Delta V_{IN}}$	$V_{OUT} + 0.5V < V_{IN} < 5V$			<b>1</b>	%
DC Output Load Regulation	$\frac{\Delta V_{OUT}}{\Delta I_{OUT}}$	$0A < I_{LOAD} < 1A$ , All voltage options	<b>-1</b>			%
Feedback Input Current		$V_{ADJ} = 0.5V$		0.01	<b>1</b>	$\mu A$
Ground Pin Current	$I_Q$	$I_{LOAD} = 0A$ , $2.2V < V_{IN} < 6V$		3	<b>5</b>	mA
		$I_{LOAD} = 1A$ , $2.2V < V_{IN} < 6V$		5	<b>7</b>	mA
Ground Pin Current in Shutdown	$I_{SHDN}$	ENABLE Pin = 0V, $V_{IN} = 6V$		0.2	<b>12</b>	$\mu A$
Dropout Voltage (Note 12)	$V_{DO}$	$I_{LOAD} = 1A$ , $V_{OUT} = 2.5V$		130	<b>212</b>	mV
Output Short Circuit Current	OCP	$V_{OUT} = 0V$ , $2.2V < V_{IN} < 6V$		1.75		A
Thermal Shutdown Temperature	TSD	$2.2V < V_{IN} < 6V$		160		°C
Thermal Shutdown Hysteresis (Rising Threshold)	TSDn	$2.2V < V_{IN} < 6V$		30		°C
<b>AC CHARACTERISTICS</b>						
Input Supply Ripple Rejection	PSRR	$f = 1kHz$ , $I_{LOAD} = 1A$ ; $V_{IN} = 2.2V$		58		dB
		$f = 120Hz$ , $I_{LOAD} = 1A$ ; $V_{IN} = 2.2V$		72		dB
Output Noise Voltage		$I_{LOAD} = 1A$ , $BW = 10Hz < f < 100kHz$		63		$\mu V_{RMS}$

**Electrical Specifications** Unless otherwise noted,  $V_{IN} = V_{OUT} + 0.4V$ ,  $V_{OUT} = 1.8V$ ,  $C_{IN} = C_{OUT} = 10\mu F$ ,  $T_J = +25^\circ C$ ,  $I_{LOAD} = 0A$ . Applications must follow thermal guidelines of the package to determine worst case junction temperature. Please refer to [“ISL78310 Schematic Block Diagram” on page 4](#) and Tech Brief [TB379](#). **Boldface limits apply across the operating temperature range, -40°C to +125°C. (Continued)**

PARAMETER	SYMBOL	TEST CONDITIONS	MIN (Note 11)	TYP	MAX (Note 11)	UNITS
<b>ENABLE PIN CHARACTERISTICS</b>						
Turn-on Threshold		$2.2V < V_{IN} < 6V$	<b>0.3</b>	0.8	<b>1</b>	V
Hysteresis (Rising Threshold)		$2.2V < V_{OUT} + 0.4V < 6V$	<b>10</b>	80	<b>200</b>	mV
Enable Pin Turn-on Delay		$C_{OUT} = 10\mu F$ , $I_{LOAD} = 1A$		100		$\mu s$
Enable Pin Leakage Current		$V_{IN} = 6V$ , $EN = 3V$			<b>1</b>	$\mu A$
<b>ADJUSTABLE INRUSH CURRENT LIMIT CHARACTERISTICS</b>						
Current limit adjust	$I_{PD}$	$V_{IN} = 3.5V$ , $EN = 0V$ , $SS = 1V$	<b>0.5</b>	1	<b>1.3</b>	mA
	$I_{CHG}$		<b>-3.3</b>	-2	<b>-0.8</b>	$\mu A$
<b>PG PIN CHARACTERISTICS</b>						
$V_{OUT}$ PG Flag Threshold			<b>75</b>	85	<b>92</b>	$\%V_{OUT}$
$V_{OUT}$ PG Flag Hysteresis				4		%
PG Flag Low Voltage		$V_{IN} = 2.5V$ , $I_{SINK} = 500\mu A$			<b>100</b>	mV
PG Flag Leakage Current		$V_{IN} = 6V$ , $PG = 6V$			<b>1</b>	$\mu A$

## NOTES:

11. Compliance to datasheet limits is assured by one or more methods: production test, characterization and/or design.
12. Dropout is defined by the difference in supply  $V_{IN}$  and  $V_{OUT}$  when the supply produces a 2% drop in  $V_{OUT}$  from its nominal value.

# Typical Operating Performance

$I_L = 0A$ .

Unless otherwise noted:  $V_{IN} = 2.2V$ ,  $V_{OUT} = 1.8V$ ,  $C_{IN} = C_{OUT} = 10\mu F$ ,  $T_J = +25^\circ C$ ,

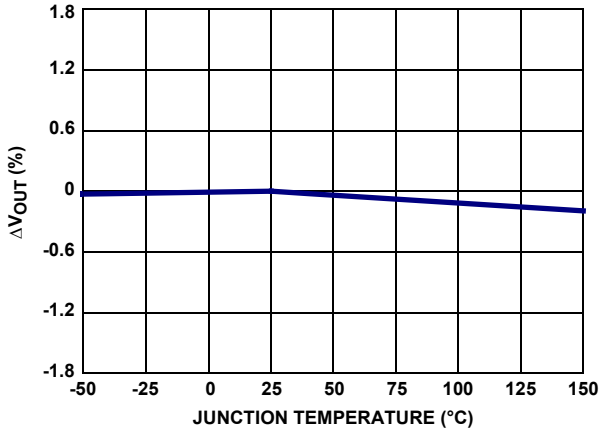

FIGURE 3.  $V_{OUT}$  vs TEMPERATURE

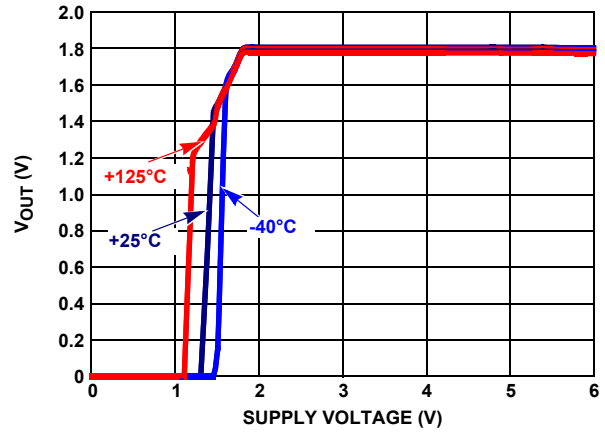

FIGURE 4.  $V_{OUT}$  vs SUPPLY VOLTAGE

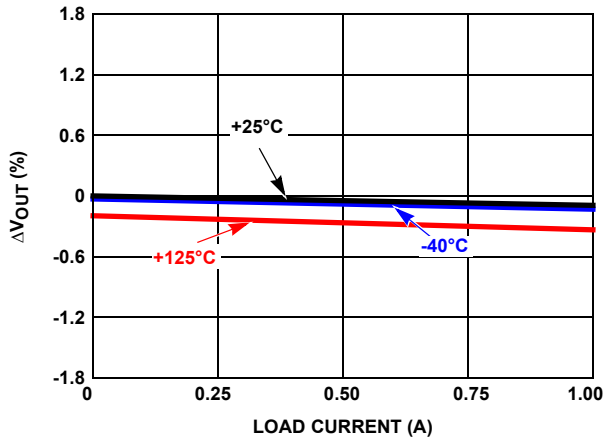

FIGURE 5.  $V_{OUT}$  vs LOAD CURRENT

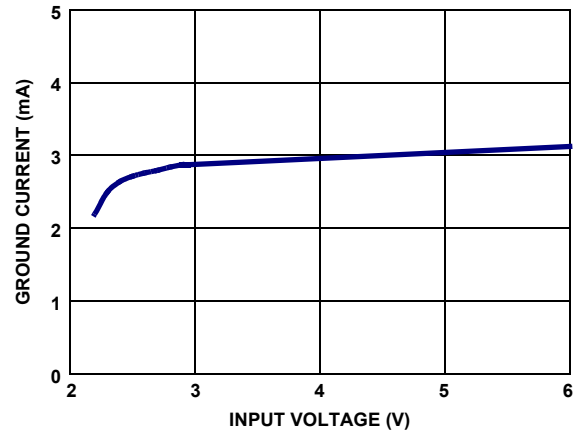

FIGURE 6. GROUND CURRENT vs SUPPLY VOLTAGE

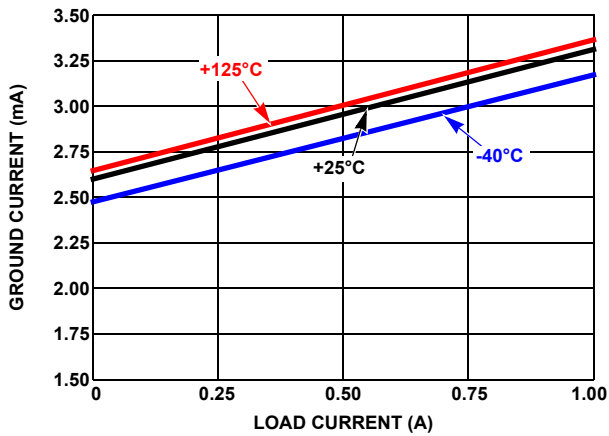

FIGURE 7. GROUND CURRENT vs LOAD CURRENT

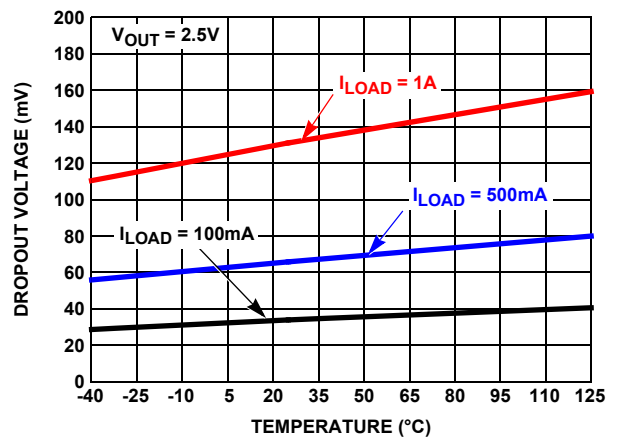

FIGURE 8. DROPOUT VOLTAGE vs TEMPERATURE

# Typical Operating Performance

Unless otherwise noted:  $V_{IN} = 2.2V$ ,  $V_{OUT} = 1.8V$ ,  $C_{IN} = C_{OUT} = 10\mu F$ ,  $T_J = +25^\circ C$ ,  $I_L = 0A$ . (Continued)

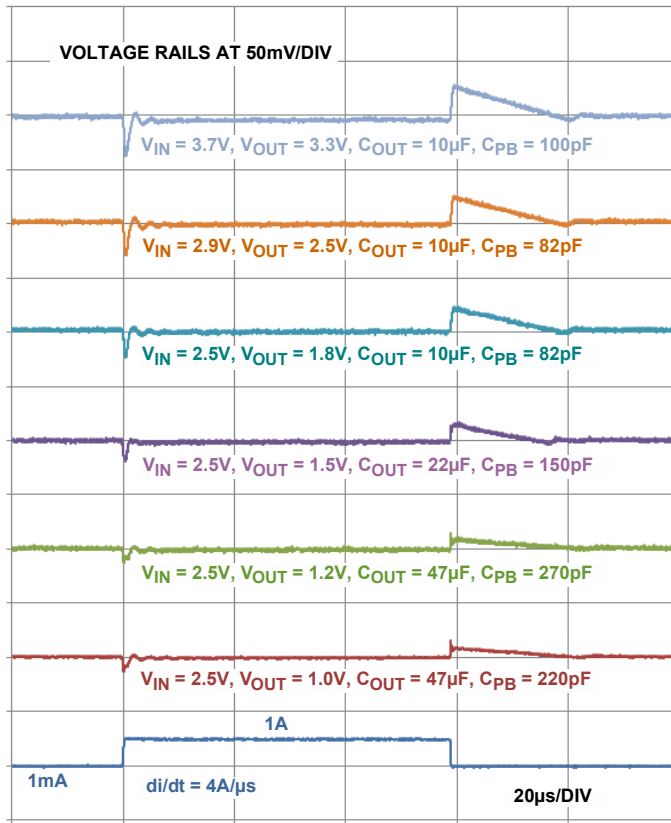

FIGURE 9. LOAD TRANSIENT RESPONSE

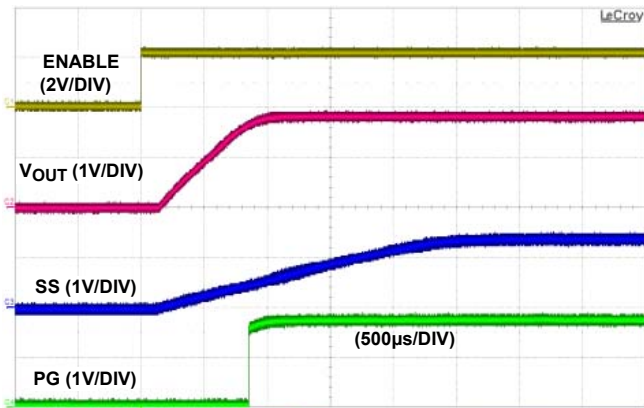

FIGURE 10. ENABLE START-UP

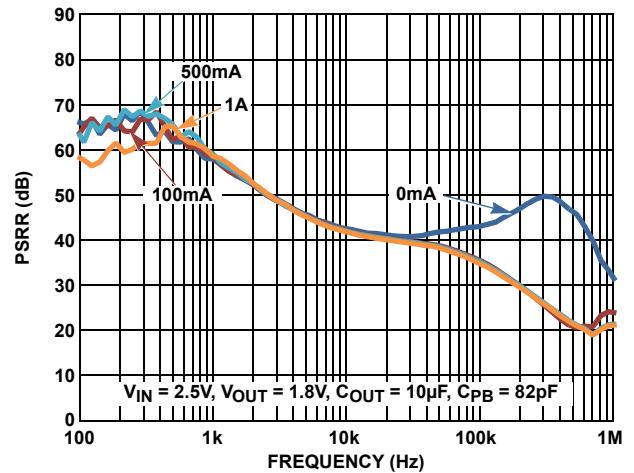

FIGURE 11. PSRR vs FREQUENCY

## Typical Operating Performance

$I_L = 0A$ . (Continued)

Unless otherwise noted:  $V_{IN} = 2.2V$ ,  $V_{OUT} = 1.8V$ ,  $C_{IN} = C_{OUT} = 10\mu F$ ,  $T_J = +25^\circ C$ ,

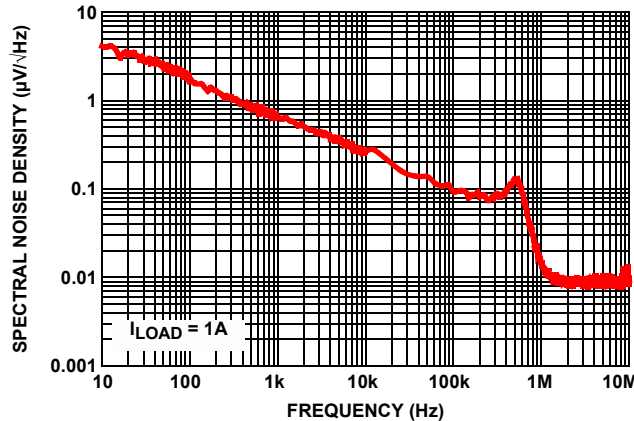

FIGURE 12. SPECTRAL NOISE DENSITY vs FREQUENCY

## Applications Information

### Input Voltage Requirements

The ISL78310 is capable of delivering output voltages from 0.8V to 5.0V. Due to the nature of an LDO,  $V_{IN}$  must be some margin higher than the output voltage plus dropout at the maximum rated current of the application if active filtering (PSRR) is expected from  $V_{IN}$  to  $V_{OUT}$ . The generous dropout specification of this family of LDOs allows applications to design for a level of efficiency that can accommodate profiles smaller than the TO220/263.

### External Capacitor Requirements

#### GENERAL GUIDELINE

External capacitors are required for proper operation. Careful attention must be paid to layout guidelines and selection of capacitor type and value to ensure optimal performance.

#### OUTPUT CAPACITOR

The ISL78310 applies state of the art internal compensation to keep the selection of the output capacitor simple for the customer. Stable operation over full temperature,  $V_{IN}$  range,  $V_{OUT}$  range and load extremes are guaranteed for all capacitor types and values assuming a minimum of  $10\mu F$  X5R/X7R is used for local bypass on  $V_{OUT}$ . This output capacitor must be connected to the  $V_{OUT}$  and GND pins of the LDO with PCB traces no longer than 0.5cm. Additional capacitors of any value in ceramic, POSCAP, alum/tantalum electrolytic types may be placed in parallel to improve PSRR at higher frequencies and/or load transient AC output voltage tolerances.

#### INPUT CAPACITOR

For proper operation, a minimum capacitance of  $10\mu F$  X5R/X7R is required at the input. This ceramic input capacitor must be connected to  $V_{IN}$  and GND pins of the LDO with PCB traces no longer than 0.5cm.

### Phase Boost Capacitor ( $C_{PB}$ )

A small phase boost capacitor,  $C_{PB}$ , can be placed across the top resistor in the feedback resistor divider network (Figure 13) in order to place a zero at:

$$F_Z = 1/(2 \cdot \pi \cdot R_{TOP} \cdot C_{PB}) \quad (EQ. 1)$$

This zero increases the crossover frequency of the LDO and provides additional phase resulting in faster load transient response.

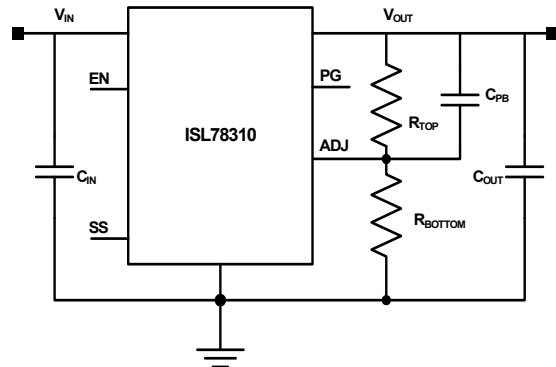

FIGURE 13.

It is also important to note that the LDO stability and load transient are affected by the type of output capacitor used. For optimal result, empirical tuning of  $C_{PB}$  is suggested for each specific application. It is recommended to not use  $C_{PB}$  when high ESR capacitors such as aluminum electrolytic or tantalum are used.

Table 1 shows the recommended  $C_{PB}$ ,  $R_{TOP}$ ,  $R_{BOTTOM}$  and  $C_{PB}$  values for different output voltage rails.

TABLE 1.

V <sub>OUT</sub> (V)	R <sub>TOP</sub> (kΩ)	R <sub>BOTTOM</sub> (Ω)	C <sub>PB</sub> (pF)	C <sub>OUT</sub> (μF)
5.0	2.61	287	100	10
3.3	2.61	464	100	10
2.5	2.61	649	82	10
1.8	2.61	1.0k	82	10
1.5*	2.61	1.3k	68	10
1.5	2.61	1.3k	150	22
1.2*	2.61	1.87k	120	22
1.2*	2.61	1.87k	270	47
1.0	2.61	2.61k	220	47
0.8	2.61	4.32k	220	47

\*Either option could be used, depending on cost/performance requirements.

## Thermal Fault Protection

In the event the die temperature exceeds typically +160°C, then the output of the LDO shuts down until the die temperature cools down to typically +130°C. The level of power, combined with the thermal resistance of the package (+48°C/W for DFN), determines whether the junction temperature exceeds the thermal shutdown temperature specified in the [“Electrical Specifications” on page 5](#) (see thermal packaging guidelines).

## Current Limit Protection

The ISL78310 LDO incorporates protection against overcurrent due to any short or overload condition applied to the output pin. The current limit circuit performs as a constant current source when the output current exceeds the current limit threshold noted in the [“Electrical Specifications” on page 5](#). If the short or

overload condition is removed from V<sub>OUT</sub>, then the output returns to normal voltage mode regulation. In the event of an overload condition on the DFN package, the LDO will begin to cycle on and off due to the die temperature exceeding thermal fault condition.

## Functional Description

### Enable Operation

The Enable turn-on threshold is typically 0.8V with a hysteresis of 80mV. The Enable pin does not have an internal pull-up or pull-down resistor. As a result, this pin must not be left floating. This pin must be tied to VIN if it is not used. A pull-up resistor (typically 1kΩ to 10kΩ) will be required for applications that use open collector or open drain outputs to control the Enable pin. The Enable pin may be connected directly to VIN for applications that are always on.

### Soft-Start Operation

The soft-start circuit controls the rate at which the output voltage rises up to regulation at power-up or LDO enable. This start-up ramp time can be set by adding an external capacitor from the SS pin to GND. An internal 2μA current source charges up this C<sub>SS</sub> and the feedback reference voltage is clamped to the voltage across it. The start-up time of the regulator output voltage for a given C<sub>SS</sub> value can be calculated using [Equation 2](#).

$$t_{\text{RAMP}} = \frac{C_{\text{SS}} \times 0.5\text{V}}{2\mu\text{A}} \quad (\text{EQ. 2})$$

The soft-start function also effectively limits the amount of in-rush current to less than the programmed current limit during start-up or an enable sequence, to avoid an overcurrent fault condition. This can be an issue for applications that require large, external bulk capacitances on V<sub>OUT</sub> where high levels of charging current can be seen for a significant period of time. High in-rush currents can cause V<sub>IN</sub> to drop below minimum, which could cause V<sub>OUT</sub> to shutdown.

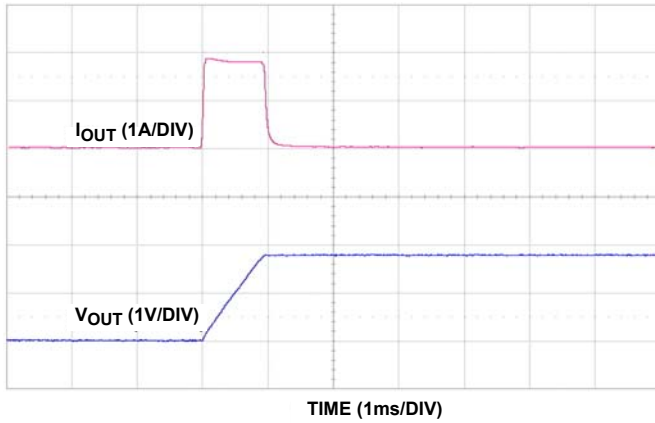

FIGURE 14. IN-RUSH CURRENT WITH NO  $C_{SS}$ ,  $C_{OUT} = 1000\mu\text{F}$ , IN-RUSH CURRENT = 1.8A

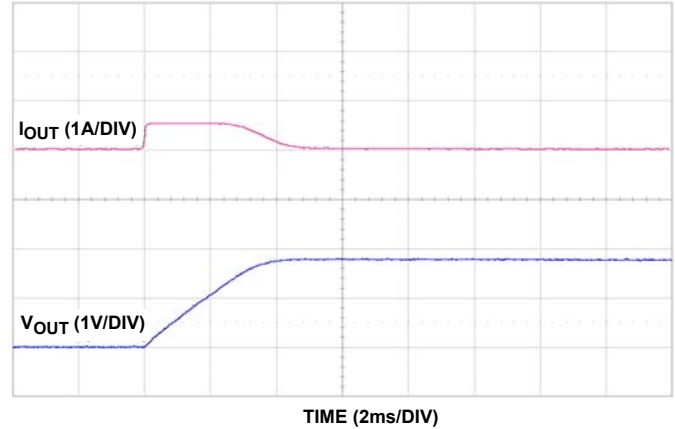

FIGURE 15. IN-RUSH CURRENT WITH  $C_{SS} = 15\text{nF}$ ,  $C_{OUT} = 1000\mu\text{F}$ , IN-RUSH CURRENT = 0.5A

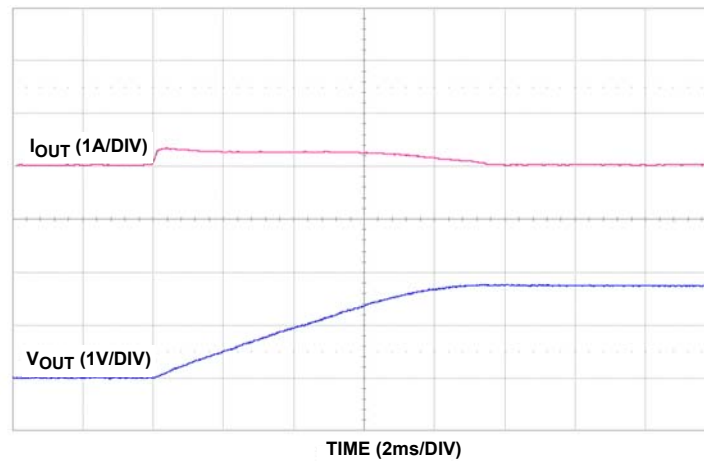

FIGURE 16. IN-RUSH CURRENT WITH  $C_{SS} = 33\text{nF}$ ,  $C_{OUT} = 1000\mu\text{F}$ , IN-RUSH CURRENT = 0.2A

[Equation 3](#) can be used to calculate  $C_{SS}$  for a desired in-rush current, where  $V_{OUT}$  is the output voltage,  $C_{OUT}$  is the total capacitance on the output, and  $I_{INRUSH}$  is the desired in-rush current.

$$C_{SS} = \frac{(V_{OUT} \times C_{OUT} \times 2\mu\text{A})}{I_{INRUSH} \times 0.5\text{V}} \quad (\text{EQ. 3})$$

The scopes in [Figures 14, 15 and 16](#) capture the response for the soft-start function. The output voltage is set to 1.8V.

The external capacitor is always discharged to ground at the beginning of start-up or enabling.

### Power-Good Operation

The PGOOD is a logic output that indicates the status of  $V_{OUT}$ . The PGOOD flag is an open-drain NMOS that can sink 10mA during a fault condition. The PGOOD pin requires an external pull-up resistor, which is typically connected to the VOUT pin. The PGOOD pin should not be pulled up to a voltage source greater than  $V_{IN}$ . The PGOOD goes low when the output voltage drops below 84% of the nominal output voltage or if the part is

disabled. The PGOOD comparator functions during current limit and thermal shutdown. For applications not using this feature, connect this pin to ground.

### Output Voltage Selection

An external resistor divider is used to scale the output voltage relative to the internal reference voltage. This voltage is then fed back to the error amplifier. The output voltage can be programmed to any level between 0.8V and 5V. An external resistor divider,  $R_1$  and  $R_2$ , is used to set the output voltage as shown in [Equation 4](#). The recommended value for  $R_2$  is 500Ω to 1kΩ.  $R_1$  is then chosen according to [Equation 5](#).

$$V_{OUT} = 0.5\text{V} \times \left( \frac{R_1}{R_2} + 1 \right) \quad (\text{EQ. 4})$$

$$R_1 = R_2 \times \left( \frac{V_{OUT}}{0.5\text{V}} - 1 \right) \quad (\text{EQ. 5})$$

## Power Dissipation

The junction temperature must not exceed the range specified in the [“Recommended Operating Conditions” on page 5](#). The power dissipation can be calculated by using [Equation 6](#):

$$P_D = (V_{IN} - V_{OUT}) \times I_{OUT} + V_{IN} \times I_{GND} \quad (\text{EQ. 6})$$

The maximum allowed junction temperature,  $T_{J(\text{MAX})}$ , and the maximum expected ambient temperature,  $T_{A(\text{MAX})}$ , will determine the maximum allowable power dissipation, as shown in [Equation 7](#):

$$P_{D(\text{MAX})} = (T_{J(\text{MAX})} - T_A) / \theta_{JA} \quad (\text{EQ. 7})$$

$\theta_{JA}$  is the junction-to-ambient thermal resistance.

For safe operation, ensure that the power dissipation  $P_D$ , calculated from [Equation 6](#), is less than the maximum allowable power dissipation  $P_{D(\text{MAX})}$ .

## Heatsinking the DFN Package

The DFN package uses the copper area on the PCB as a heat-sink. The EPAD of this package must be soldered to the copper plane (GND plane) for heat sinking. [Figure 17](#) shows a curve for the  $\theta_{JA}$  of the DFN package for different copper area sizes.

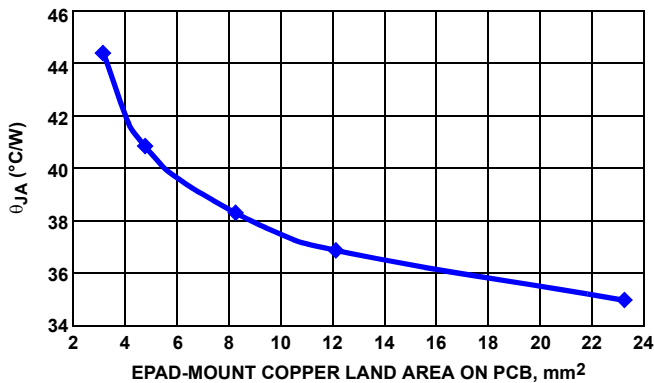

FIGURE 17. 3mmx3mm 10 LD DFN ON 4-LAYER PCB WITH THERMAL VIAS  $\theta_{JA}$  vs EPAD-MOUNT COPPER LAND AREA ON PCB

## General Power PAD Design Considerations

[Figure 18](#) shows the recommended use of vias on the thermal pad to remove heat from the IC. This typical array populates the thermal pad footprint with vias spaced three times the radius distance from the center of each via. Small via size is advisable, but not to the extent that solder reflow becomes difficult.

All vias should be connected to the pad potential, with low thermal resistance for efficient heat transfer. Complete connection of the plated-through hole to each plane is important. It is not recommended to use “thermal relief” patterns to connect the vias.

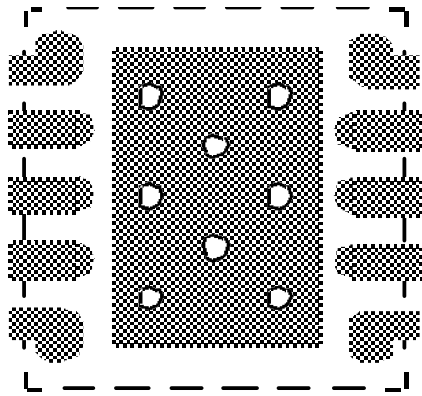

FIGURE 18. PCB VIA PATTERN

## Revision History

The revision history provided is for informational purposes only and is believed to be accurate, but not warranted. Please go to web to make sure you have the latest Rev.

DATE	REVISION	CHANGE
November 7, 2014	FN7810.2	<a href="#">"Absolute Maximum Ratings" on page 5</a> : Updated CDM testing from: Charged Device Model (Tested per JESD22-C101E) to Charged Device Model (Tested per AEC Q100-011). On <a href="#">page 2</a> : Removed part number ISL78310ARAJZ-TR5303 from ordering information table. Updated POD from rev 6 to rev 9.
December 23, 2013	FN7810.1	Page 12 - 2nd line of the disclaimer changed from: "Intersil products are manufactured, assembled and tested utilizing ISO9001 quality systems as noted" to: "Intersil Automotive Qualified products are manufactured, assembled and tested utilizing TS16949 quality systems as noted".
February 17, 2011	FN7810.0	Initial Release.

## About Intersil

Intersil Corporation is a leading provider of innovative power management and precision analog solutions. The company's products address some of the largest markets within the industrial and infrastructure, mobile computing and high-end consumer markets.

For the most updated datasheet, application notes, related documentation and related parts, please see the respective product information page found at [www.intersil.com](http://www.intersil.com).

You may report errors or suggestions for improving this datasheet by visiting [www.intersil.com/ask](http://www.intersil.com/ask).

Reliability reports are also available from our website at [www.intersil.com/support](http://www.intersil.com/support)

© Copyright Intersil Americas LLC 2011-2014. All Rights Reserved.  
All trademarks and registered trademarks are the property of their respective owners.

For additional products, see [www.intersil.com/en/products.html](http://www.intersil.com/en/products.html)

Intersil Automotive Qualified products are manufactured, assembled and tested utilizing TS16949 quality systems as noted in the quality certifications found at [www.intersil.com/en/support/qualandreliability.html](http://www.intersil.com/en/support/qualandreliability.html)

*Intersil products are sold by description only. Intersil may modify the circuit design and/or specifications of products at any time without notice, provided that such modification does not, in Intersil's sole judgment, affect the form, fit or function of the product. Accordingly, the reader is cautioned to verify that datasheets are current before placing orders. Information furnished by Intersil is believed to be accurate and reliable. However, no responsibility is assumed by Intersil or its subsidiaries for its use; nor for any infringements of patents or other rights of third parties which may result from its use. No license is granted by implication or otherwise under any patent or patent rights of Intersil or its subsidiaries.*

For information regarding Intersil Corporation and its products, see [www.intersil.com](http://www.intersil.com)

# Package Outline Drawing

## L10.3x3

10 LEAD DUAL FLAT PACKAGE (DFN)

Rev 9, 10/13

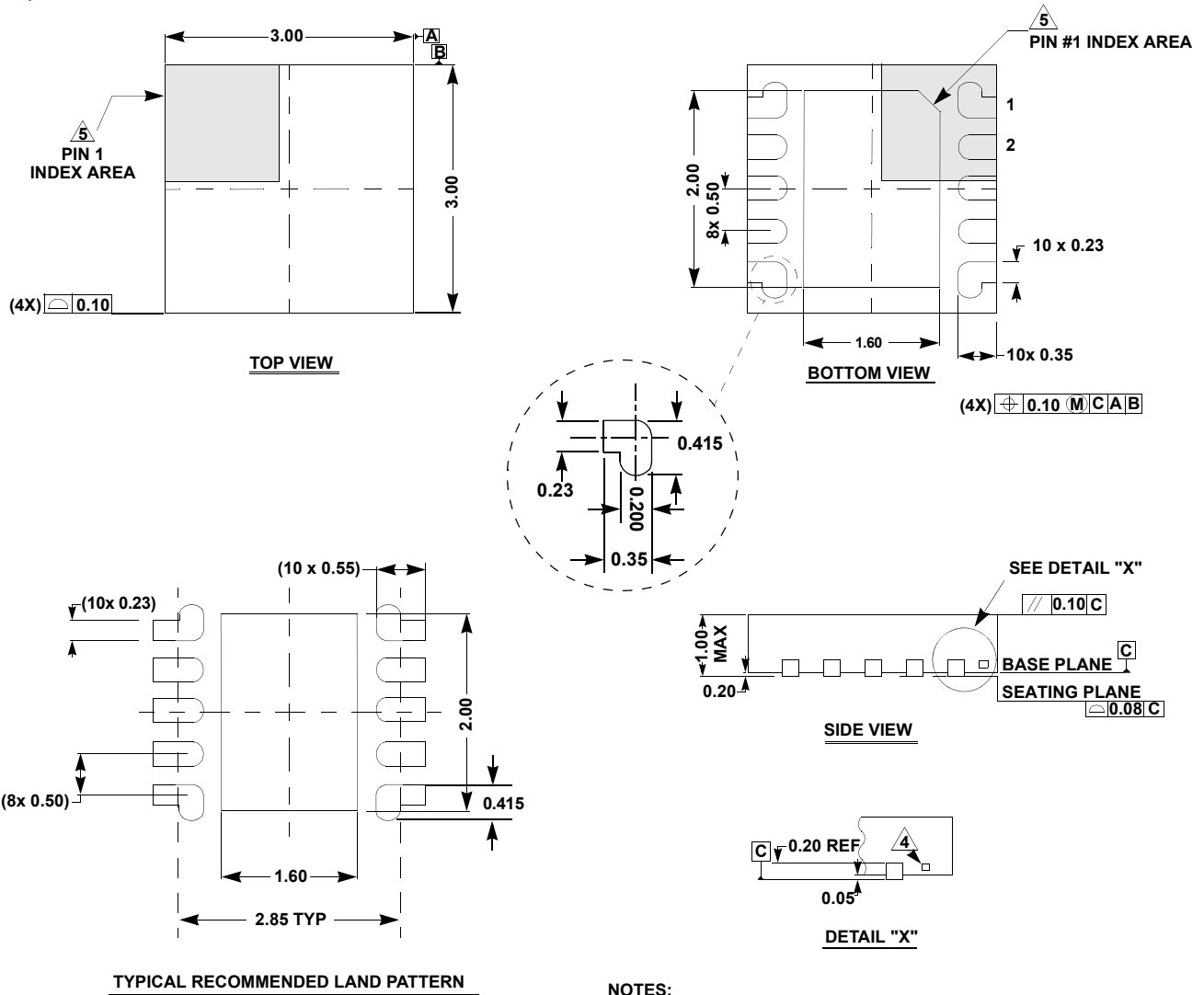

**NOTES:**

- Dimensions are in millimeters.  
Dimensions in ( ) for Reference Only.
- Dimensioning and tolerancing conform to ASME Y14.5m-1994.
- Unless otherwise specified, tolerance : Decimal  $\pm 0.05$
4. Tiebar shown (if present) is a non-functional feature.
5. The configuration of the pin #1 identifier is optional, but must be located within the zone indicated. The pin #1 identifier may be either a mold or mark feature.

## Looking for pricing, stock, or lifecycle information?

Click below to explore more details on WIN SOURCE:

-  [View ISL78310ARAJZ-T7A on WIN SOURCE](#)
-  [Renesas Electronics America](#) Information

## Optimize Your Supply Chain with WIN SOURCE Solutions

-  Global Sourcing Solution
-  Obsolete Management
-  Cost Control Management
-  Shortage Management
-  Alternative Solution
-  Excess Inventory Management