



**THE DATASHEET OF  
ISL78219ARTZ**



ISL78219

Automotive Boost Regulator with 4A Integrated Switch

FN8941  
Rev.0.00  
Mar 22, 2018

The [ISL78219](#) is a high frequency, high efficiency current-mode control non-synchronous step-up voltage regulator operated at a constant PWM switching frequency. It has an internal 4.0A, 120mΩ low-side MOSFET and can deliver high output current and efficiency over 90%. The selectable 640kHz and 1.22MHz switching frequencies provide faster transient response and allow the use of a smaller inductor. An external compensation pin provides flexibility in setting frequency compensation, allowing the use of low ESR small ceramic output capacitors.

When in shutdown mode, the ISL78219 draws current at <1μA and can operate at as low as 2.3V input. These features, along with higher switching frequency, allow use of tiny external components and minimize the overall PCB footprint.

The ISL78219 is available in a 10 Ld TDFN package with a maximum height of 0.8mm. The device is offered for AEC-Q100 Grade 2 operation with an ambient temperature range of -40°C to +105°C.

**Related Literature**

For a full list of related documents, visit our website

- [ISL78219](#) product page

**Features**

- 4.0A, low  $r_{DS(ON)}$  integrated low-side MOSFET
- +2.3V to +6.0V operating input voltage range
- $V_{OUT}$  operating range:  $1.1 * V_{IN}$  to 24V
- 640kHz or 1.22MHz switching frequency
- High efficiency: 93% for  $5V_{IN}$ ,  $12V_{OUT}$  at 0.5A
- Adjustable soft-start
- Internal thermal protection
- 0.8mm maximum height 10 Ld TDFN package
- Pb-free (RoHS compliant)
- Halogen free
- [AEC-Q100](#) Grade 2: -40°C to +105°C

**Applications**

- Satellite camera systems
- Auxiliary cooling fans
- Antenna and microphone supplies

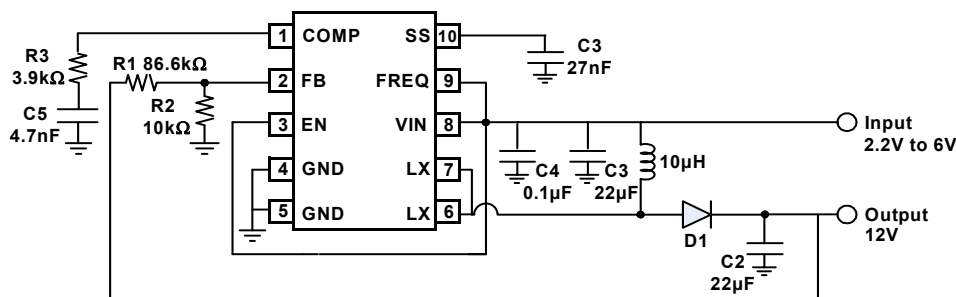

Figure 1. Typical Application Circuit

## 1. Overview

### 1.1 Block Diagram

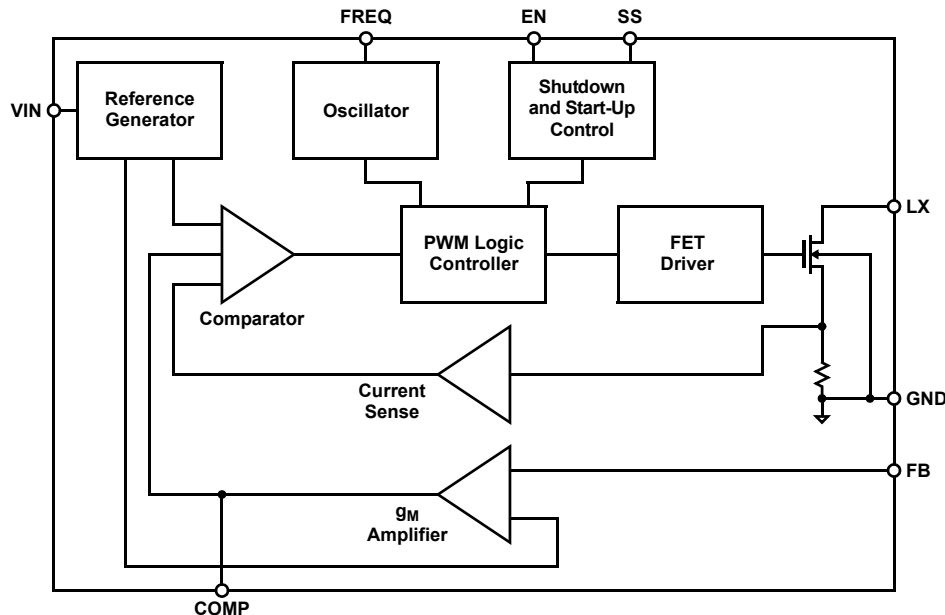

Figure 2. Block Diagram

### 1.2 Ordering Information

Part Number (Notes 2, 3)	Part Marking	Temperature Range (°C)	Tape and Reel (Units) (Note 1)	Package (RoHS-Compliant)	Pkg. Dwg. #
ISL78219ARTZ	8219	-40 to +105	-	10 Ld TDFN	L10.3x3B
ISL78219ARTZ-T	8219	-40 to +105	6k	10 Ld TDFN	L10.3x3B
ISL78219EV1Z	Evaluation board				

Notes:

1. Refer to [TB347](#) for details about reel specifications.
2. These Pb-free plastic packaged products employ special Pb-free material sets, molding compounds/die attach materials, and 100% matte tin plate plus anneal (e3 termination finish, which is RoHS compliant and compatible with both SnPb and Pb-free soldering operations). Pb-free products are MSL classified at Pb-free peak reflow temperatures that meet or exceed the Pb-free requirements of IPC/JEDEC J STD-020.
3. For Moisture Sensitivity Level (MSL), refer to the [ISL78219](#) product information page. For more information about MSL, refer to [TB363](#).

### 1.3 Pin Configuration

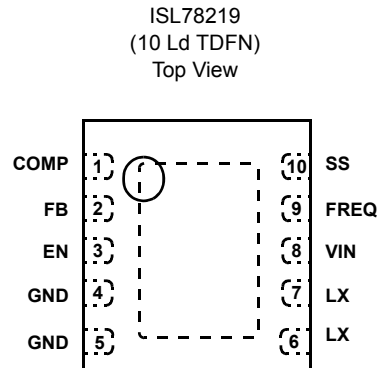

### 1.4 Pin Descriptions

Pin Number	Pin Name	Description
1	COMP	Compensation pin. Output of the internal error amplifier. Capacitor and resistor from COMP pin to ground.
2	FB	Voltage feedback pin. Internal reference is 1.24V nominal. Connect a resistor divider from $V_{OUT}$ . $V_{OUT} = 1.24V (1 + R_1/R_2)$ . See <a href="#">Figure 1 on page 1</a> .
3	EN	Enable control pin. Pull the pin high to turn the device ON.
4, 5	GND	Power ground.
6, 7	LX	Power switch pin. Connected to the drain of the internal power MOSFET.
8	VIN	Analog power supply input pin.
9	FREQ	Frequency select pin. When the FREQ pin is set low, the switching frequency is set to 640kHz. When set high, the switching frequency is set to 1.22MHz.
10	SS	Soft-start control pin. Connect a capacitor to control the converter output slew rate.

## 2. Specifications

### 2.1 Absolute Maximum Ratings

$T_A = +25^\circ\text{C}$

Parameter	Minimum	Maximum	Unit
Terminal Voltage with Respect to GND			
V <sub>IN</sub> to GND		6.5	V
LX to GND		26	V
COMP, FB, EN, SS, FREQ to GND	-0.3	(V <sub>IN</sub> + 0.3)	V
<b>ESD Rating</b>	<b>Value</b>		<b>Unit</b>
Human Body Model (Tested per JS-001-2014)	1.5		kV
Charged Device Model (Tested per JS-002-2014)	1.2		kV

CAUTION: Do not operate at or near the maximum ratings listed for extended periods of time. Exposure to such conditions may adversely impact product reliability and result in failures not covered by warranty.

### 2.2 Thermal Information

Thermal Resistance (Typical)	$\theta_{JA}$ ( $^\circ\text{C}/\text{W}$ )	$\theta_{JC}$ ( $^\circ\text{C}/\text{W}$ )
10 Ld TDFN Package ( <a href="#">Notes 4, 5</a> )	45.8	3.4

Notes:

- $\theta_{JA}$  is measured in free air with the component mounted on a high-effective thermal conductivity test board with "direct attach" features. See [TB379](#).
- For  $\theta_{JC}$ , the "case temp" location is the center of the exposed metal pad on the package underside.

Parameter	Minimum	Maximum	Unit
Temperature Under Bias	-40	+105	$^\circ\text{C}$
Storage Temperature	-65	+150	$^\circ\text{C}$
Maximum Continuous Junction Temperature		+135	$^\circ\text{C}$
Pb-Free Reflow Profile	see <a href="#">TB493</a>		

### 2.3 Recommended Operating Conditions

Parameter	Minimum	Maximum	Unit
Operating Temperature	-40	105	$^\circ\text{C}$
V <sub>IN</sub>	-2.3	+5.5	V
V <sub>OUT</sub>	1.1 * V <sub>IN</sub>	24	V

## 2.4 Electrical Specifications

$V_{IN} = 3V$ ,  $V_{OUT} = 12V$ ,  $I_{OUT} = 0mA$ ,  $FREQ = GND$ ,  $T_A = -40^{\circ}C$  to  $+105^{\circ}C$ , unless otherwise specified. **Boldface limits apply over the operating temperature range,  $-40^{\circ}C$  to  $+105^{\circ}C$ .**

Parameter	Symbol	Test Conditions	Min (Note 6)	Typ	Max (Note 6)	Unit
Shutdown Supply Current	$I_{DD-SHDN}$	EN = 0V		0.1	<b>5</b>	$\mu A$
Standby Supply Current	$I_{DD-STDBY}$	EN = $V_{IN}$ , FB = 1.3V		0.7		mA
Active Supply Current	$I_{DD-ACTIVE}$	EN = $V_{IN}$ , FB = 1.0V		3	<b>5</b>	mA
Feedback Voltage	$V_{FB}$		<b>1.22</b>	1.24	<b>1.26</b>	V
Feedback Input Bias Current	$I_{DD-FB}$			0.01	<b>0.5</b>	$\mu A$
Input Voltage Range	$V_{IN}$		<b>2.3</b>		<b>6.0</b>	V
Maximum Duty Cycle	$D_{MAX}$ - 640kHz	FREQ = 0V	<b>85</b>	92		%
Maximum Duty Cycle	$D_{MAX}$ - 1.2MHz	FREQ = $V_{IN}$	<b>85</b>	90		%
Current Limit - Max Peak Input Current	$I_{LIM}$		<b>3.65</b>	4.0	<b>5.1</b>	A
EN Pin Input Bias Current	$I_{EN}$	EN = 0V		0.01	<b>1.0</b>	$\mu A$
Switch ON Resistance	$r_{DS(ON)}$	$V_{IN} = 2.7V$ , $I_{LX} = 1A$		0.12		$\Omega$
Switch Leakage Current	$I_{LX-LEAK}$	$V_{SW} = 26V$		0.01	<b>3</b>	$\mu A$
Line Regulation	$\Delta V_{OUT}/\Delta V_{IN}$	$2.3V < V_{IN} < 5.5V$ , $V_{OUT} = 12V$		0.2		%
Load Regulation	$\Delta V_{OUT}/\Delta I_{OUT}$	$V_{IN} = 3.3V$ , $V_{OUT} = 12V$ , $I_O = 30mA$ to 200mA		0.3		%
Switching Frequency Accuracy	$F_{OSC1}$	FREQ = 0V	<b>500</b>	640	<b>740</b>	kHz
Switching Frequency Accuracy	$F_{OSC2}$	FREQ = $V_{IN}$	<b>1000</b>	1220	<b>1500</b>	kHz
EN, FREQ Pin Input Low Level	$V_{IL}$				<b>0.5</b>	V
EN, FREQ Pin Input High Level	$V_{IH}$		<b>1.5</b>			V
Error Amp Transconductance	$g_M$		<b>70</b>	130	<b>250</b>	$\mu A/V$
VIN UVLO Threshold Rising	$V_{INUVLO}$		<b>2.00</b>	2.10	<b>2.30</b>	V
VIN UVLO Hysteresis	$V_{INUVLO-HYST}$			50		mV
Soft-Start Charge Current	$I_{SS}$		<b>2.5</b>	4.5	<b>7.5</b>	$\mu A$
Over-Temperature Protection	$T_{OTP}$			150		$^{\circ}C$

Note:

6. Parameters with MIN and/or MAX limits are 100% tested at  $+25^{\circ}C$ , unless otherwise specified. Temperature limits established by characterization and are not production tested.

### 3. Typical Performance Curves

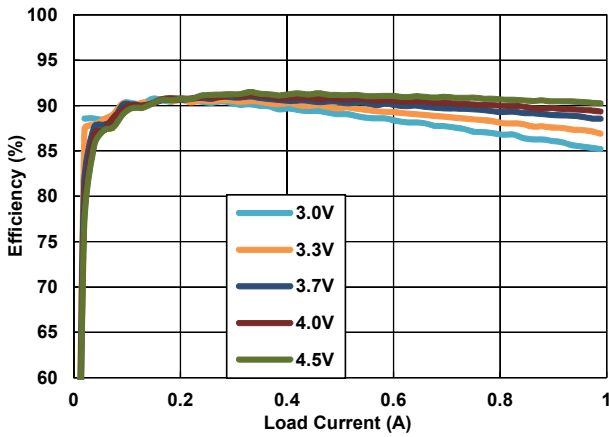

Figure 3. Regulator Efficiency ( $V_{OUT} = 5V$  Efficiency at  $f_{sw} = 640kHz$ ,  $C_{load} = 44\mu F$ ,  $Comp = 3.9k$  and  $4700pF$ )

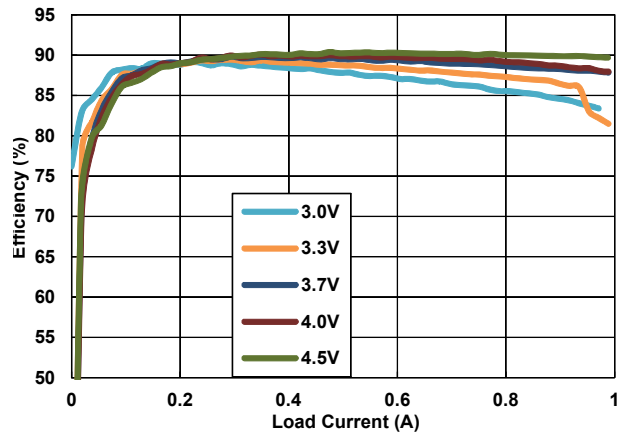

Figure 4. Regulator Efficiency ( $V_{OUT} = 5V$  Efficiency at  $f_{sw} = 1.22MHz$ ,  $C_{load} = 44\mu F$ ,  $Comp = 3.9k$  and  $4700pF$ )

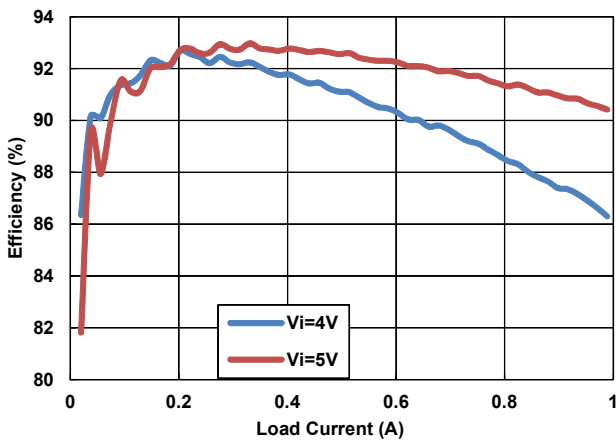

Figure 5. Regulator Efficiency ( $V_{OUT} = 9.2V$ ,  $f = 640kHz$ ,  $C_{load} = 22\mu F$ ,  $Comp = 3.9k$  and  $4700pF$ )

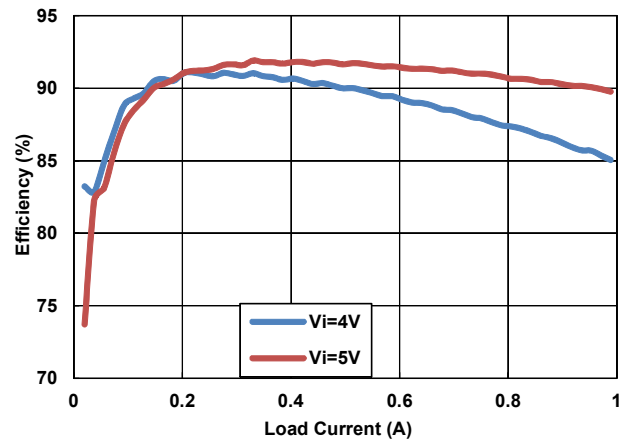

Figure 6. Regulator Efficiency ( $V_{OUT} = 9.2V$ ,  $f = 1.22MHz$ ,  $C_{load} = 22\mu F$ ,  $Comp = 3.9k$  and  $4700pF$ )

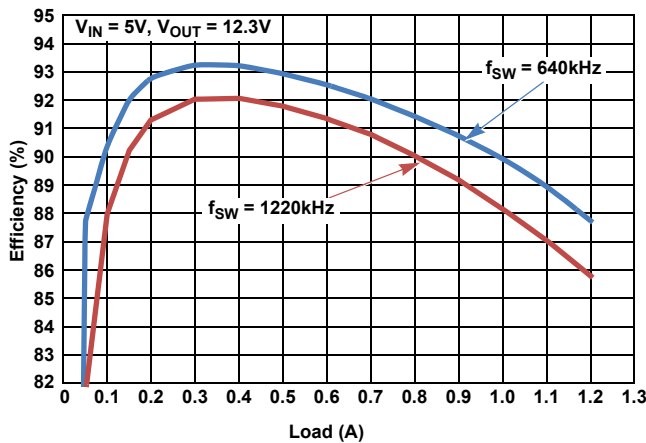

Figure 7.  $V_{OUT} = 12.3V$  Efficiency

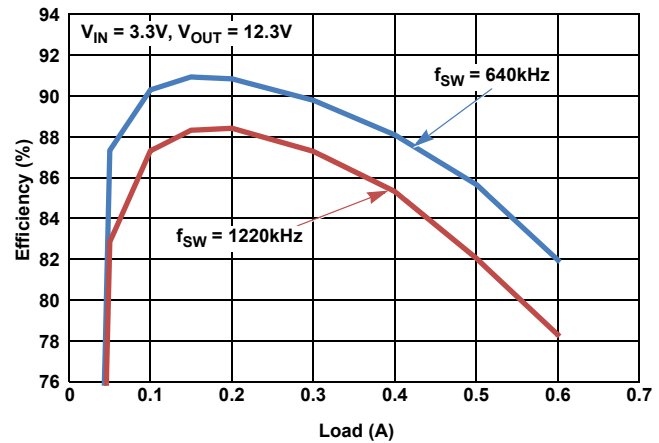

Figure 8.  $V_{OUT} = 12.3V$  Efficiency

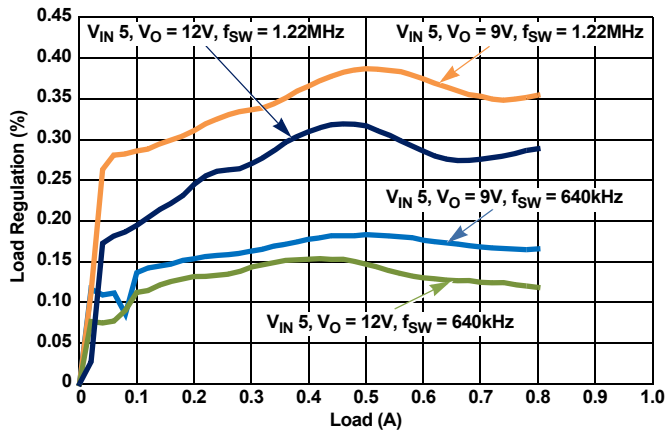

Figure 9.  $V_{IN} = 5V$ , Load Regulation

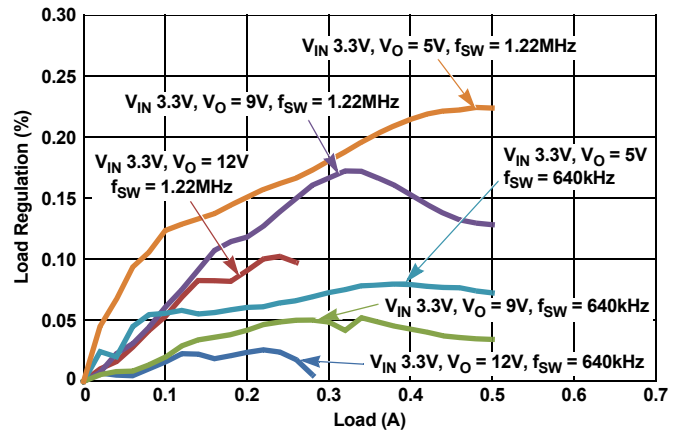

Figure 10.  $V_{IN} = 3.3V$ , Load Regulation

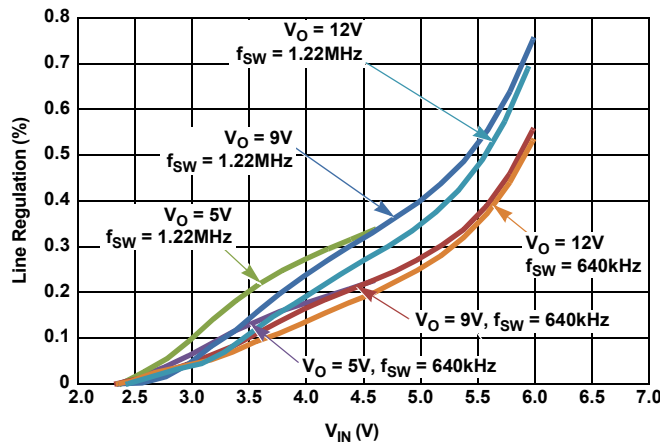

Figure 11. Line Regulation

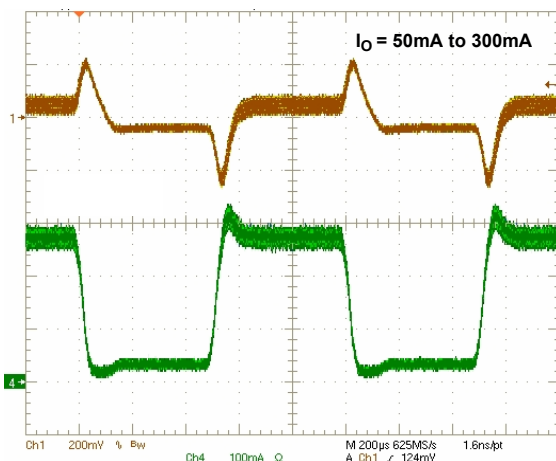

Figure 12.  $V_{IN} = 3.3V, V_O = 12V, f_{SW} = 1.22MHz$ , Transient Response

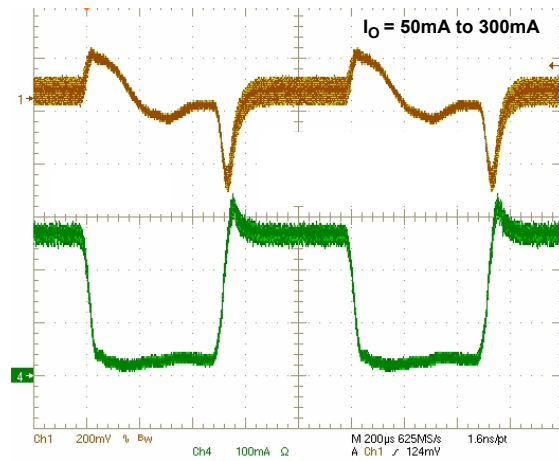

Figure 13.  $V_{IN} = 3.3V, V_O = 12V, f_{SW} = 640kHz$ , Transient Response

## 4. Applications Information

The ISL78219 is a high frequency, high efficiency boost regulator operated at constant frequency PWM mode. The boost converter stores energy from an input voltage source and delivers higher output voltage. The input voltage range is 2.3V to 6.0V and the output voltage range is 5V to 24V. The switching frequency can be selected between 640kHz and 1.22MHz. The higher switching frequency allows use of smaller inductors and faster transient response. An external compensation pin gives the user greater flexibility in setting output transient response and tighter load regulation. The converter soft-start characteristic can be controlled by the external  $C_{SS}$  capacitor. The EN pin allows the user to shut down the device.

### 4.1 Boost Converter Operations

[Figure 14 on page 9](#) shows a boost converter with all the key components. In steady state and continuous conduction mode, the boost converter operates in two cycles. During the first cycle, as shown in [Figure 15 on page 9](#), the internal power FET turns on and the Schottky diode is reverse biased and cuts off the current flow to the output. The output current is supplied from the output capacitor. The voltage across the inductor is  $V_{IN}$  and the inductor current ramps up with a rate of  $V_{IN}/L$ , where  $L$  is the inductance. The inductor is magnetized and energy is stored in the inductor. The change in inductor current is shown in [Equation 1](#):

$$(EQ. 1) \quad \Delta I_{L1} = \Delta T1 \times \frac{V_{IN}}{L}$$

$$\Delta T1 = \frac{D}{f_{SW}}$$

$D = \text{Duty Cycle}$

$$\Delta V_O = \frac{I_{OUT}}{C_{OUT}} \times \Delta T_1$$

During the second cycle, the integrated power FET turns off and the Schottky diode is forward biased (see [Figure 16 on page 9](#)). The energy stored in the inductor is supplied to the output. This energy is used to charge the output capacitor and supply output current. In this cycle switching node (LX) is held to  $V_{OUT} + \text{Schottky diode drop}$ . Voltage drop across the inductor is  $V_{IN} - V_{OUT}$  (ignoring diode drop across Schottky diode). The change in inductor current during the second cycle is shown in [Equation 2](#):

$$(EQ. 2) \quad \Delta I_L = \Delta T2 \times \frac{V_{IN} - V_{OUT}}{L}$$

$$\Delta T2 = \frac{1 - D}{f_{SW}}$$

In steady state operation, the change in the inductor current must be equal as shown in [Equation 3](#).

$$(EQ. 3) \quad \Delta I1 + \Delta I2 = 0$$

$$\frac{D}{f_{SW}} \times \frac{V_{IN}}{L} + \frac{1 - D}{f_{SW}} \times \frac{V_{IN} - V_{OUT}}{L} = 0$$

$$\frac{V_{OUT}}{V_{IN}} = \frac{1}{1 - D}$$

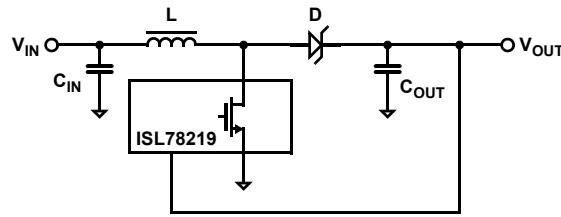

Figure 14. Boost Converter

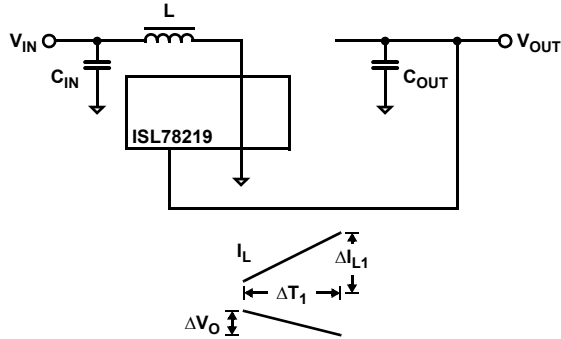

Figure 15. Boost Converter - Cycle 1, Power Switch Closed

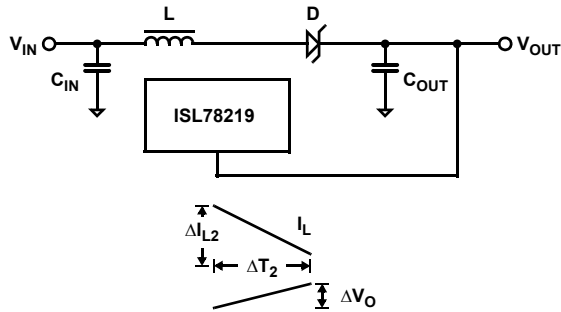

Figure 16. Boost Converter - Cycle 2, Power Switch Open

## 4.2 Output Voltage

An external feedback resistor divider is required to divide the output voltage down to the nominal 1.24V reference voltage. Limit the current drawn by the resistor network to maintain the overall converter efficiency. The maximum value of the resistor network is limited by the feedback input bias current and the potential for noise being coupled into the feedback pin. A resistor network less than 100k is recommended. The boost converter output voltage is determined by the relationship as shown in [Equations 4](#). The nominal VFB voltage is 1.24V.

$$(EQ. 4) \quad V_{OUT} = V_{FB} \times \left(1 + \frac{R_1}{R_2}\right)$$

### 4.3 Inductor Selection

Inductor selection determines the output ripple voltage, transient response, output current capability, and efficiency. Its selection depends on the input voltage, output voltage, switching frequency, and maximum output current. For most applications, the inductance should be in the range of 2μH to 33μH. The inductor maximum DC current specification must be greater than the peak inductor current required by the regulator. The peak inductor current can be calculated using [Equation 5](#):

$$(EQ. 5) \quad I_{L(PEAK)} = \frac{I_{OUT} \times V_{OUT}}{V_{IN}} + 1/2 \times \frac{V_{IN} \times (V_{OUT} - V_{IN})}{L \times V_{OUT} \times FREQ}$$

### 4.4 Output Capacitor

Use low ESR capacitors to minimize the output voltage ripple. Multilayer ceramic capacitors such as X5R and X7R types are preferred for the output capacitors because of their lower ESR and small packages. Tantalum capacitors with higher ESR can also be used. Calculate the output ripple using [Equation 6](#):

$$(EQ. 6) \quad \Delta V_O = \frac{I_{OUT} \times D}{f_{SW} \times C_O} + I_{OUT} \times ESR$$

For noise sensitive applications, Renesas recommends placing a 0.1μF in parallel with the larger output capacitor to reduce the switching noise coupled from the LX switching node.

### 4.5 Schottky Diode

When selecting the Schottky diode, the reverse break-down voltage, forward current, and forward voltage drop must be considered for optimum converter performance. The diode must be rated to handle 4.0A, the current limit of the ISL78219. The breakdown voltage must exceed the maximum output voltage. Low forward voltage drop, low leakage current, and fast reverse recovery will help the converter to achieve the maximum efficiency.

### 4.6 Input Capacitor

The value of the input capacitor depends on the input and the output voltages, maximum output current, inductor value, and maximum permissible noise fed back in the input line. For most applications, a minimum 10μF is required. For applications that run close to the maximum output current limit, an input capacitor in the range of 22μF to 47μF is recommended.

The ISL78219 is powered from VIN. Renesas recommends placing a high frequency 0.1μF bypass capacitor close to the VIN pin to reduce supply line noise and ensure stable operation.

### 4.7 Loop Compensation

The ISL78219 incorporates a transconductance amplifier in its feedback path to allow the user some adjustment on the transient response and better regulation. The ISL78219 uses current mode control architecture, which has a fast current sense loop and a slow voltage feedback loop. The fast current feedback loop does not require any compensation. The slow voltage loop must be compensated for stable operation. The compensation network is a series RC network from the COMP pin to ground. The resistor sets the high frequency integrator gain for fast transient response and the capacitor sets the integrator zero to ensure loop stability. For most applications, the compensation resistor is in the range of 0k to 2.0k and the compensation capacitor is in the range of 3nF to 10nF.

### 4.8 Soft-Start

The regulator goes through the soft-start sequence after EN is pulled high. The soft-start is provided by an internal 4.5μA current source. This internal current source charges an external C<sub>SS</sub> capacitor. The peak MOSFET current is limited by the voltage on the capacitor. As the voltage at the C<sub>SS</sub> capacitor increases, the current limit ramps up from 0A to full scale. This in turn controls the rising rate of the output voltage.

## 4.9 Frequency Selection

The ISL78219 switching frequency can be user selectable. The ISL78219 operates at either constant 640kHz or 1.22MHz switching frequency. Connecting the FREQ pin to ground sets the PWM switching frequency to 640kHz. When connecting FREQ high or  $V_{IN}$ , the switching frequency is set to 1.22MHz.

## 4.10 Shutdown Control

When the EN pin is pulled low, the ISL78219 is in shutdown mode, reducing the supply current to  $<1\mu A$ .

## 4.11 Maximum Output Current

The MOSFET current limit is nominally 4.0A and ensured to 3.8A. This restricts the maximum output current,  $I_{OMAX}$ , based on [Equation 7](#):

$$(EQ. 7) \quad I_L = I_{L(AVG)} + (1/2 \times \Delta I_L)$$

where:

$I_L$  = MOSFET current limit

$I_{L(AVG)}$  = average inductor current

$\Delta I_L$  = inductor ripple current

$$(EQ. 8) \quad \Delta I_L = \frac{V_{IN} \times [(V_O + V_{DIODE}) - V_{IN}]}{L \times (V_O + V_{DIODE}) \times f_{SW}}$$

$V_{DIODE}$  = Schottky diode forward voltage, typically 0.6V

$f_{SW}$  = switching frequency (640kHz or 1.22MHz)

$$(EQ. 9) \quad I_{L-AVG} = \frac{I_{OUT}}{1-D}$$

where:

D = MOSFET turn-on ratio:

$$(EQ. 10) \quad D = 1 - \frac{V_{IN}}{V_{OUT} + V_{DIODE}}$$

## 4.12 Cascaded MOSFET Application

A 24V N-Channel MOSFET is integrated in the boost regulator. For applications in which the output voltage is greater than 24V, an external cascaded MOSFET is needed, as shown in [Figure 17](#). The voltage rating of the external MOSFET should be greater than  $V_{IN}$ .

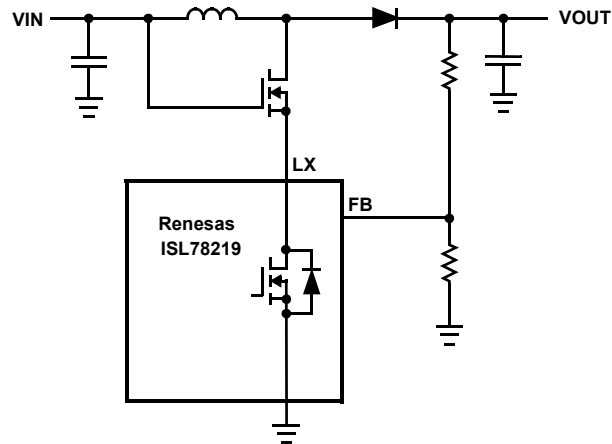

Figure 17. Cascaded MOSFET Topology for High Output Voltage Applications

### 4.12.1 DC Path Block Application

The boost converter has a DC path from the input to the output through the inductor and diode. In the non-synchronous topology, the output voltage will be the input voltage minus the forward voltage diode drop of the Schottky diode although the system is still in shutdown mode. If this voltage is not desired, use the following circuit (see [Figure 18](#)) to disconnect the DC path between the input and inductor when the ISL78219 is in shutdown mode.

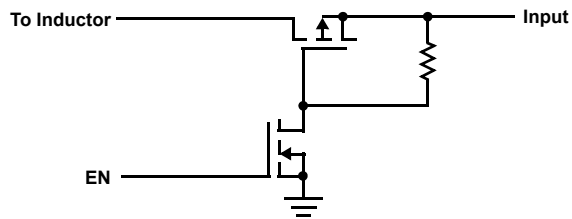

Figure 18. Circuit to Disconnect the DC Path of the Boost Converter

## 5. Revision History

Rev.	Date	Description
0.00	Mar 22, 2018	Initial release.

## 6. Package Outline Drawing

For the most recent package outline drawing, see [L10.3x3B](#).

L10.3x3B  
 10 LEAD THIN DUAL FLAT PACKAGE (TDFN) WITH E-PAD  
 Rev 4, 4/15

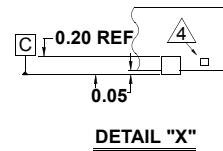
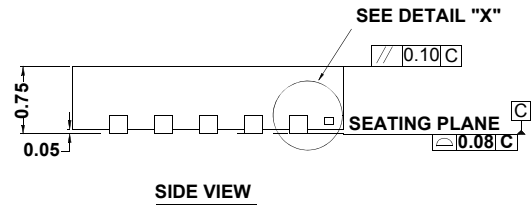
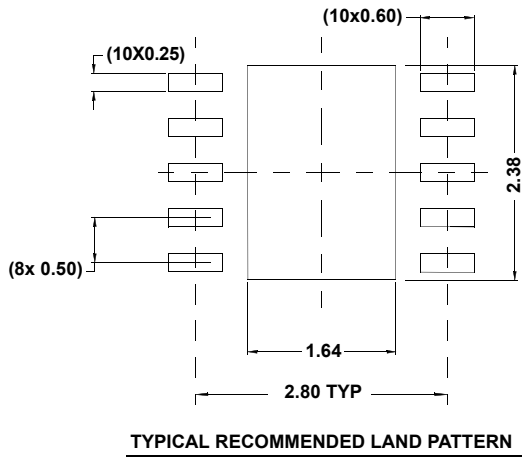
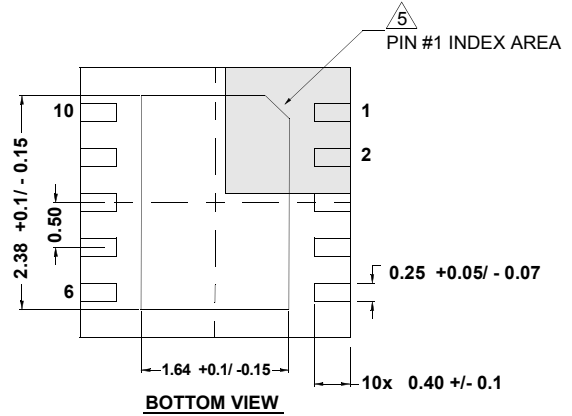
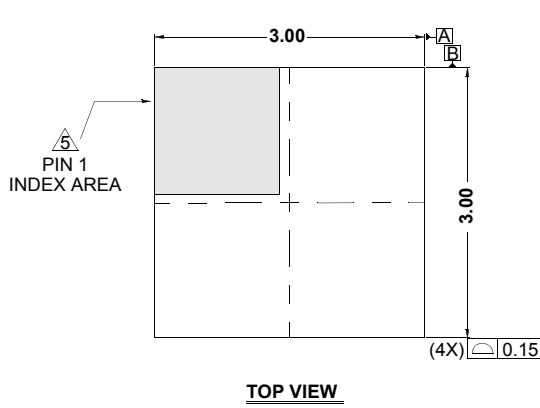

**NOTES:**

1. Dimensions are in millimeters.  
Dimensions in ( ) for Reference Only.
2. Dimensioning and tolerancing conform to AMSE Y14.5m-1994.
3. Unless otherwise specified, tolerance : Decimal ± 0.05
4. Tiebar shown (if present) is a non-functional feature and may be located on any of the 4 sides (or ends).
5. The configuration of the pin #1 identifier is optional, but must be located within the zone indicated. The pin #1 identifier may be either a mold or mark feature.

## Notice

1. Descriptions of circuits, software and other related information in this document are provided only to illustrate the operation of semiconductor products and application examples. You are fully responsible for the incorporation or any other use of the circuits, software, and information in the design of your product or system. Renesas Electronics disclaims any and all liability for any losses and damages incurred by you or third parties arising from the use of these circuits, software, or information.
2. Renesas Electronics hereby expressly disclaims any warranties against and liability for infringement or any other claims involving patents, copyrights, or other intellectual property rights of third parties, by or arising from the use of Renesas Electronics products or technical information described in this document, including but not limited to, the product data, drawings, charts, programs, algorithms, and application examples.
3. No license, express, implied or otherwise, is granted hereby under any patents, copyrights or other intellectual property rights of Renesas Electronics or others.
4. You shall not alter, modify, copy, or reverse engineer any Renesas Electronics product, whether in whole or in part. Renesas Electronics disclaims any and all liability for any losses or damages incurred by you or third parties arising from such alteration, modification, copying or reverse engineering.
5. Renesas Electronics products are classified according to the following two quality grades: "Standard" and "High Quality". The intended applications for each Renesas Electronics product depends on the product's quality grade, as indicated below.  
"Standard": Computers; office equipment; communications equipment; test and measurement equipment; audio and visual equipment; home electronic appliances; machine tools; personal electronic equipment; industrial robots; etc.  
"High Quality": Transportation equipment (automobiles, trains, ships, etc.); traffic control (traffic lights); large-scale communication equipment; key financial terminal systems; safety control equipment; etc.  
Unless expressly designated as a high reliability product or a product for harsh environments in a Renesas Electronics data sheet or other Renesas Electronics document, Renesas Electronics products are not intended or authorized for use in products or systems that may pose a direct threat to human life or bodily injury (artificial life support devices or systems; surgical implantations; etc.), or may cause serious property damage (space system; undersea repeaters; nuclear power control systems; aircraft control systems; key plant systems; military equipment; etc.). Renesas Electronics disclaims any and all liability for any damages or losses incurred by you or any third parties arising from the use of any Renesas Electronics product that is inconsistent with any Renesas Electronics data sheet, user's manual or other Renesas Electronics document.
6. When using Renesas Electronics products, refer to the latest product information (data sheets, user's manuals, application notes, "General Notes for Handling and Using Semiconductor Devices" in the reliability handbook, etc.), and ensure that usage conditions are within the ranges specified by Renesas Electronics with respect to maximum ratings, operating power supply voltage range, heat dissipation characteristics, installation, etc. Renesas Electronics disclaims any and all liability for any malfunctions, failure or accident arising out of the use of Renesas Electronics products outside of such specified ranges.
7. Although Renesas Electronics endeavors to improve the quality and reliability of Renesas Electronics products, semiconductor products have specific characteristics, such as the occurrence of failure at a certain rate and malfunctions under certain use conditions. Unless designated as a high reliability product or a product for harsh environments in a Renesas Electronics data sheet or other Renesas Electronics document, Renesas Electronics products are not subject to radiation resistance design. You are responsible for implementing safety measures to guard against the possibility of bodily injury, injury or damage caused by fire, and/or danger to the public in the event of a failure or malfunction of Renesas Electronics products, such as safety design for hardware and software, including but not limited to redundancy, fire control and malfunction prevention, appropriate treatment for aging degradation or any other appropriate measures. Because the evaluation of microcomputer software alone is very difficult and impractical, you are responsible for evaluating the safety of the final products or systems manufactured by you.
8. Please contact a Renesas Electronics sales office for details as to environmental matters such as the environmental compatibility of each Renesas Electronics product. You are responsible for carefully and sufficiently investigating applicable laws and regulations that regulate the inclusion or use of controlled substances, including without limitation, the EU RoHS Directive, and using Renesas Electronics products in compliance with all these applicable laws and regulations. Renesas Electronics disclaims any and all liability for damages or losses occurring as a result of your noncompliance with applicable laws and regulations.
9. Renesas Electronics products and technologies shall not be used for or incorporated into any products or systems whose manufacture, use, or sale is prohibited under any applicable domestic or foreign laws or regulations. You shall comply with any applicable export control laws and regulations promulgated and administered by the governments of any countries asserting jurisdiction over the parties or transactions.
10. It is the responsibility of the buyer or distributor of Renesas Electronics products, or any other party who distributes, disposes of, or otherwise sells or transfers the product to a third party, to notify such third party in advance of the contents and conditions set forth in this document.
11. This document shall not be reprinted, reproduced or duplicated in any form, in whole or in part, without prior written consent of Renesas Electronics.
12. Please contact a Renesas Electronics sales office if you have any questions regarding the information contained in this document or Renesas Electronics products.  
(Note 1) "Renesas Electronics" as used in this document means Renesas Electronics Corporation and also includes its directly or indirectly controlled subsidiaries.  
(Note 2) "Renesas Electronics product(s)" means any product developed or manufactured by or for Renesas Electronics.

(Rev.4.0-1 November 2017)



### SALES OFFICES

Renesas Electronics Corporation

<http://www.renesas.com>

Refer to "<http://www.renesas.com/>" for the latest and detailed information.

#### **Renesas Electronics America Inc.**

1001 Murphy Ranch Road, Milpitas, CA 95035, U.S.A.  
Tel: +1-408-432-8888, Fax: +1-408-434-5351

#### **Renesas Electronics Canada Limited**

9251 Yonge Street, Suite 8309 Richmond Hill, Ontario Canada L4C 9T3  
Tel: +1-905-237-2004

#### **Renesas Electronics Europe Limited**

Dukes Meadow, Millboard Road, Bourne End, Buckinghamshire, SL8 5FH, U.K  
Tel: +44-1628-651-700, Fax: +44-1628-651-804

#### **Renesas Electronics Europe GmbH**

Arcadiastrasse 10, 40472 Düsseldorf, Germany  
Tel: +49-211-6503-0, Fax: +49-211-6503-1327

#### **Renesas Electronics (China) Co., Ltd.**

Room 1709 Quantum Plaza, No.27 ZhichunLu, Haidian District, Beijing, 100191 P. R. China  
Tel: +86-10-8235-1155, Fax: +86-10-8235-7679

#### **Renesas Electronics (Shanghai) Co., Ltd.**

Unit 301, Tower A, Central Towers, 555 Langao Road, Putuo District, Shanghai, 200333 P. R. China  
Tel: +86-21-2226-0888, Fax: +86-21-2226-0999

#### **Renesas Electronics Hong Kong Limited**

Unit 1601-1611, 16/F., Tower 2, Grand Century Place, 193 Prince Edward Road West, Mongkok, Kowloon, Hong Kong  
Tel: +852-2265-6688, Fax: +852 2886-9022

#### **Renesas Electronics Taiwan Co., Ltd.**

13F, No. 363, Fu Shing North Road, Taipei 10543, Taiwan  
Tel: +886-2-8175-9600, Fax: +886 2-8175-9670

#### **Renesas Electronics Singapore Pte. Ltd.**

80 Bendemeer Road, Unit #06-02 Hyflux Innovation Centre, Singapore 339949  
Tel: +65-6213-0200, Fax: +65-6213-0300

#### **Renesas Electronics Malaysia Sdn.Bhd.**

Unit 1207, Block B, Menara Amcorp, Amcorp Trade Centre, No. 18, Jln Persiaran Barat, 46050 Petaling Jaya, Selangor Darul Ehsan, Malaysia  
Tel: +60-3-7955-9390, Fax: +60-3-7955-9510

#### **Renesas Electronics India Pvt. Ltd.**



No.777C, 100 Feet Road, HAL 2nd Stage, Indiranagar, Bangalore 560 038, India  
Tel: +91-80-67208700, Fax: +91-80-67208777

#### **Renesas Electronics Korea Co., Ltd.**

17F, KAMCO Yangjae Tower, 262, Gangnam-daero, Gangnam-gu, Seoul, 06265 Korea  
Tel: +82-2-558-3737, Fax: +82-2-558-5338

## Looking for pricing, stock, or lifecycle information?

Click below to explore more details on WIN SOURCE:

-  [View ISL78219ARTZ on WIN SOURCE](#)
-  [Renesas Electronics America](#) Information

## Optimize Your Supply Chain with WIN SOURCE Solutions

-  Global Sourcing Solution
-  Obsolete Management
-  Cost Control Management
-  Shortage Management
-  Alternative Solution
-  Excess Inventory Management