



**THE DATASHEET OF  
LT1431MPS8#PBF**



## FEATURES

- **Guaranteed 0.4% Initial Voltage Tolerance**
- **0.1Ω Typical Dynamic Output Impedance**
- Fast Turn-On
- Sink Current Capability, 1mA to 100mA
- Low Reference Pin Current
- Available in J8, N8, S8 or 3-Lead TO-92 Z Packages

## APPLICATIONS

- Linear Regulators
- Adjustable Power Supplies
- Switching Power Supplies

LT, LT, LTC, LTM, Linear Technology and the Linear logo are registered trademarks and ThinSOT is a trademark of Linear Technology Corporation. All other trademarks are the property of their respective owners.

## DESCRIPTION

The LT<sup>®</sup>1431 is an adjustable shunt voltage regulator with 100mA sink capability, 0.4% initial reference voltage tolerance and 0.3% typical temperature stability. On-chip divider resistors allow the LT1431 to be configured as a 5V shunt regulator, with 1% initial voltage tolerance and requiring no additional external components. By adding two external resistors, the output voltage may be set to any value between 2.5V and 36V. The nominal internal current limit of 100mA may be decreased by including one external resistor.

A simplified 3-pin version, the LT1431CZ/LT1431IZ, is available for applications as an adjustable reference and is pin compatible with the TL431.

## TYPICAL APPLICATION

Isolated 5V Regulator

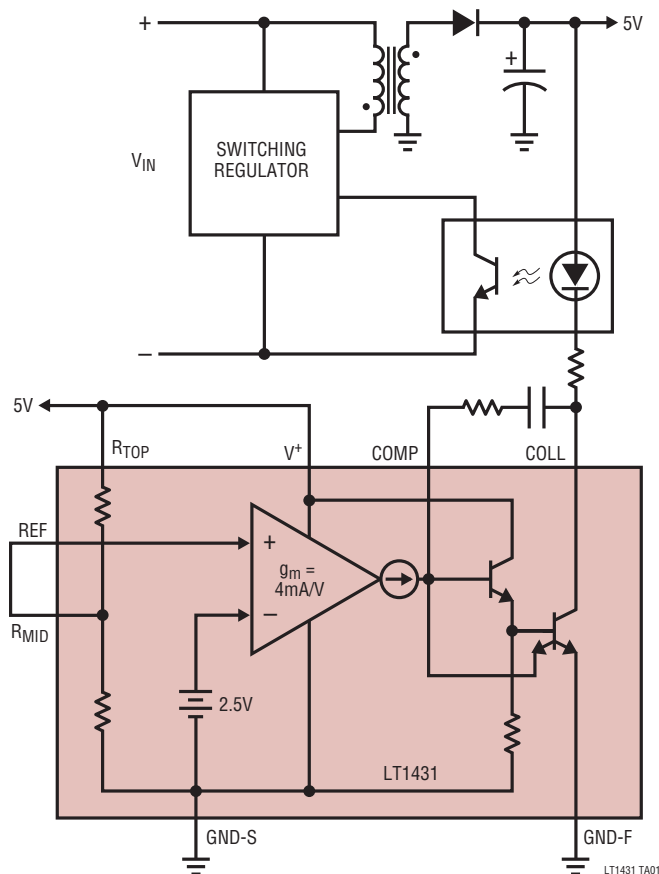

$V_{REF}$  vs Temperature

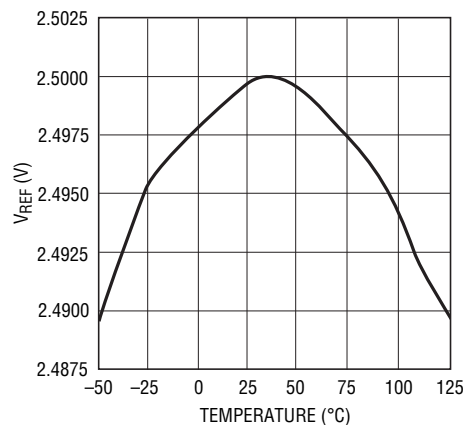

# LT1431

## ABSOLUTE MAXIMUM RATINGS (Note 1)

$V^+$ , $V_{\text{COLLECTOR}}$ .....	36V
$V_{\text{COMP}}$ , $R_{\text{TOP}}$ , $R_{\text{MID}}$ , $V_{\text{REF}}$ .....	6V
GND-F to GND-S .....	0.7V
Ambient Temperature Range	
LT1431M, LT1431MP .....	-55°C to 125°C
LT1431I .....	-40°C to 85°C
LT1431C .....	0°C TO 70°C

Junction Temperature Range	
LT1431M, LT1431MP .....	-55°C to 150°C
LT1431I .....	-40°C to 100°C
LT1431C .....	0°C to 100°C
Storage Temperature Range .....	
	-65°C to 150°C
Lead Temperature (Soldering, 10 sec).....	
	300°C

## PIN CONFIGURATION

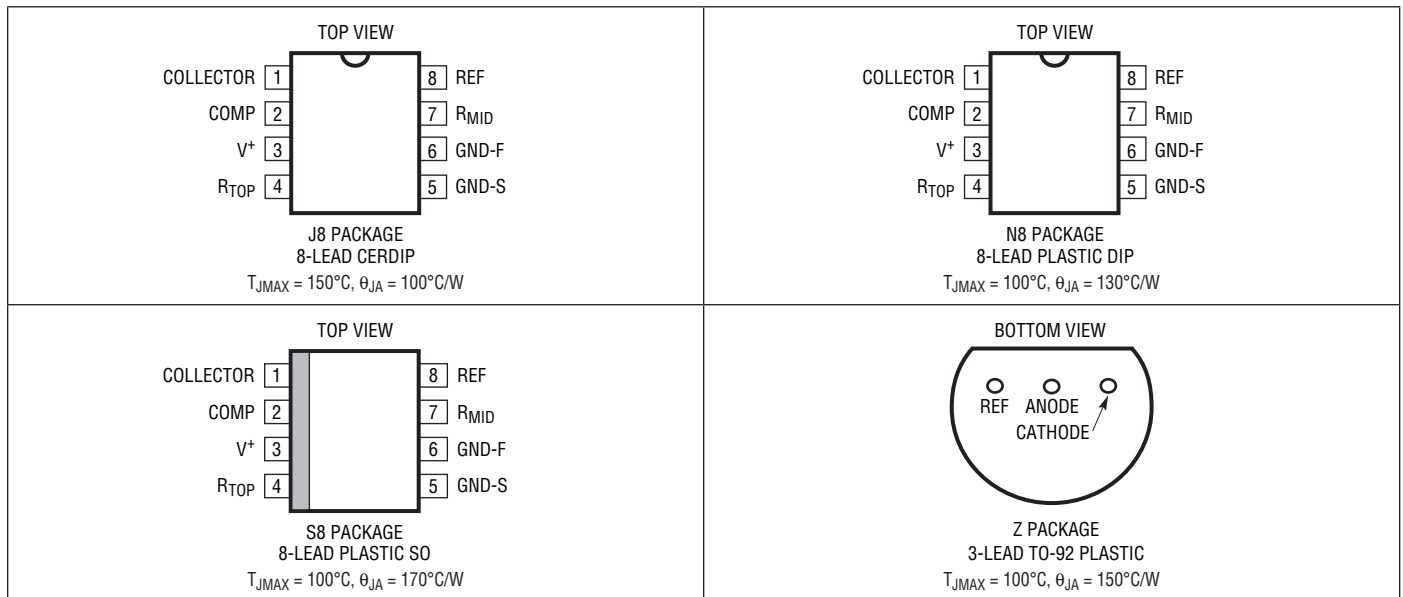

## ORDER INFORMATION

LEAD FREE FINISH	TAPE AND REEL	PART MARKING	PACKAGE DESCRIPTION	TEMPERATURE RANGE
LT1431CN8#PBF	LT1431CN8#TRPBF	LT1431 CN8	8-Lead Plastic DIP	0°C to 70°C
LT1431IN8#PBF	LT1431IN8#TRPBF	LT1431 IN8	8-Lead Plastic DIP	-40°C to 85°C
LT1431CS8#PBF	LT1431CS8#TRPBF	LT1431	8-Lead Plastic SO	0°C to 70°C
LT1431IS8#PBF	LT1431IS8#TRPBF	LT1431I	8-Lead Plastic SO	-40°C to 85°C
LT1431MPS8#PBF	LT1431MPS8#TRPBF	LT1431	8-Lead Plastic SO	-55°C to 125°C
LT1431MJ8#PBF	LT1431MJ8#TRPBF	LT1431 MJ8	8-Lead CERDIP	-55°C to 125°C
LT1431CZ#PBF	LT1431CZ#TRPBF	LT1431 CZ	3-Lead TO-92 Plastic	0°C to 70°C
LT1431IZ#PBF	LT1431IZ#TRPBF	LT1431 IZ	3-Lead TO-92 Plastic	-40°C to 85°C

Consult LTC Marketing for parts specified with wider operating temperature ranges.

Consult LTC Marketing for information on non-standard lead based finish parts.

For more information on lead free part marking, go to: <http://www.linear.com/leadfree/>

For more information on tape and reel specifications, go to: <http://www.linear.com/tapeandreeel/>

**ELECTRICAL CHARACTERISTICS** The ● denotes the specifications which apply over the full operating temperature range, otherwise specifications are at  $T_A = 25^\circ\text{C}$ .  $I_K = 10\text{mA}$  unless otherwise specified (Note 2)

SYMBOL	PARAMETER	CONDITIONS	LT1431I, LT1431M			LT1431C			UNITS	
			MIN	TYP	MAX	MIN	TYP	MAX		
$V_{REF}$	Reference Voltage	$V_{KA} = 5\text{V}$ , $I_K = 2\text{mA}$ , (Note 3)	● 2.490 2.465	2.500	2.510 2.535	2.490 2.480	2.500	2.510 2.520	V V	
$\Delta V_{REF}/\Delta T$	Reference Drift	$V_{KA} = 5\text{V}$ , $I_K = 2\text{mA}$	●	50			30		ppm/°C	
$\Delta V_{REF}/\Delta V_{KA}$	Voltage Ratio, Reference to Cathode (Open-Loop Gain)	$I_K = 2\text{mA}$ , $V_{KA} = 3\text{V}$ to $36\text{V}$	●	0.2	0.5		0.2	0.5	mV/V	
$ I_{REF} $	Reference Input Current	$V_{KA} = 5\text{V}$ , $T_A = 25^\circ\text{C}$	●	0.2	1.0 1.5		0.2	1.0 1.2	$\mu\text{A}$ $\mu\text{A}$	
$I_{MIN}$	Minimum Operating Current	$V_{KA} = V_{REF}$ to $36\text{V}$		0.6	1.0		0.6	1.0	mA	
$ I_{OFF} $	Off-State Cathode Current	$V_{KA} = 36\text{V}$ , $V_{REF} = 0\text{V}$	●		1 15		1 2		$\mu\text{A}$ $\mu\text{A}$	
$ I_{LEAK} $	Off-State Collector Leakage Current	$V_{COLL} = 36\text{V}$ , $V^+ = 5\text{V}$ , $V_{REF} = 2.4\text{V}$	●		1 5		1 2		$\mu\text{A}$ $\mu\text{A}$	
$ Z_{KA} $	Dynamic Impedance	$V_{KA} = V_{REF}$ , $I_K = 1\text{mA}$ to $100\text{mA}$ , $f \leq 1\text{kHz}$			0.2		0.2		$\Omega$	
$I_{LIM}$	Collector Current Limit	$V_{KA} = V_{REF} + 50\text{mV}$	●	80	360	100		260	mA	
	5V Reference Output	Internal Divider Used, $I_K = 2\text{mA}$		4.950	5.000	5.050	4.950	5.000	5.050	V

**Note 1:** Stresses beyond those listed under Absolute Maximum Ratings may cause permanent damage to the device. Exposure to any Absolute Maximum Rating condition for extended periods may affect device reliability and lifetime.

**Note 2:**  $V_{KA}$  is the cathode voltage of the LT1431CZ/IZ and corresponds to  $V^+$  of the LT1431CN8/IN8/CS8/IS8.  $I_K$  is the cathode current of the

LT1431CZ/IZ and corresponds to  $I(V^+) + I_{COLLECTOR}$  of the LT1431CN8/IN8/CS8/IS8.

**Note 3:** The LT1431 has bias current cancellation which is effective only for  $V_{KA} \geq 3\text{V}$ . A slight ( $\approx 2\text{mV}$ ) shift in reference voltage occurs when  $V_{KA}$  drops below  $3\text{V}$ . For this reason, these tests are not performed at  $V_{KA} = V_{REF}$ .

## TYPICAL PERFORMANCE CHARACTERISTICS

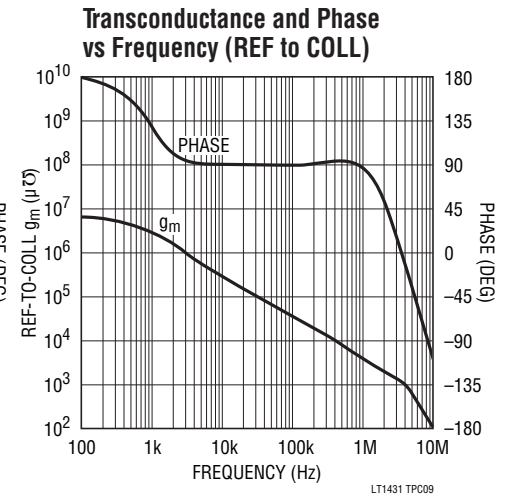
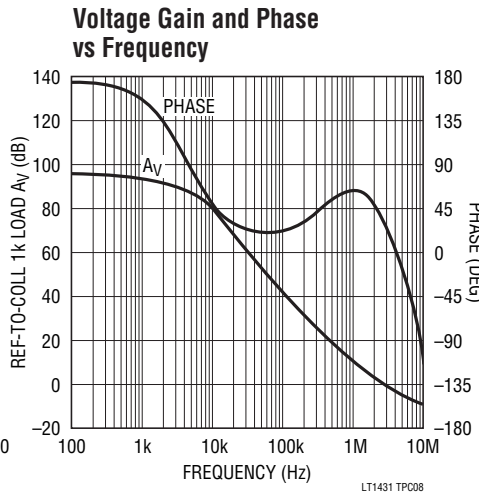
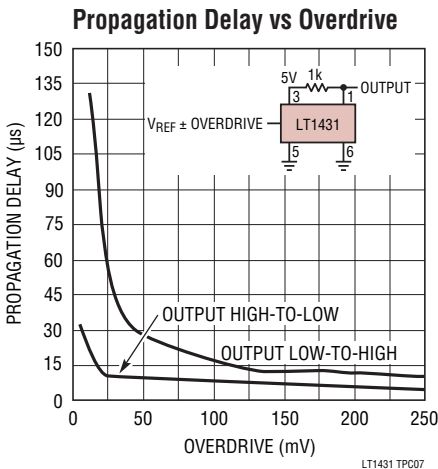
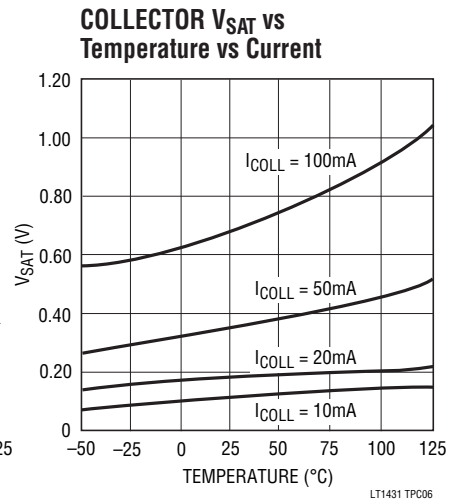
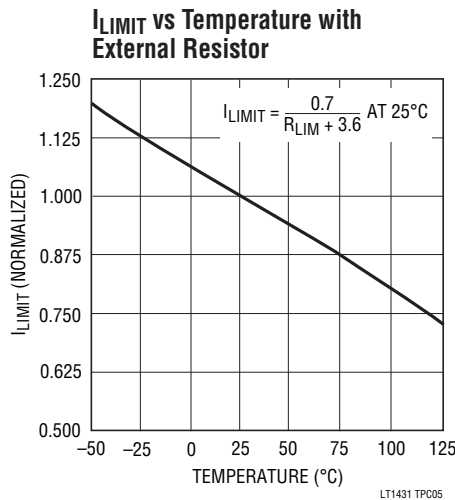
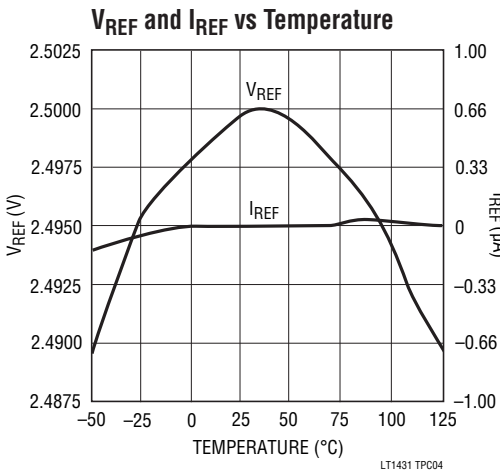
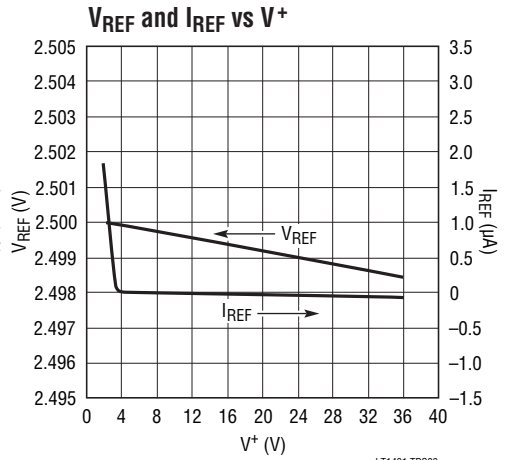
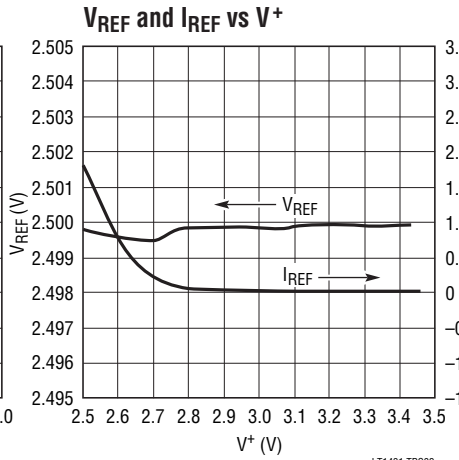
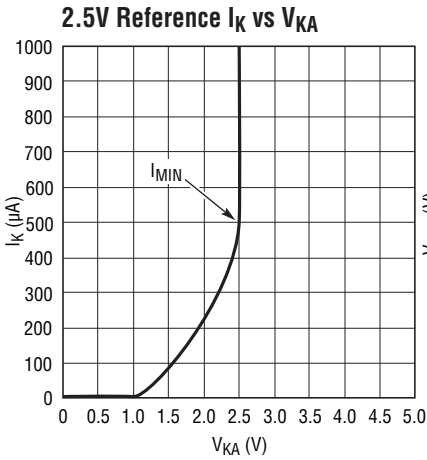

# TYPICAL PERFORMANCE CHARACTERISTICS

**Transconductance and Phase vs Frequency (Ref to Comp)**

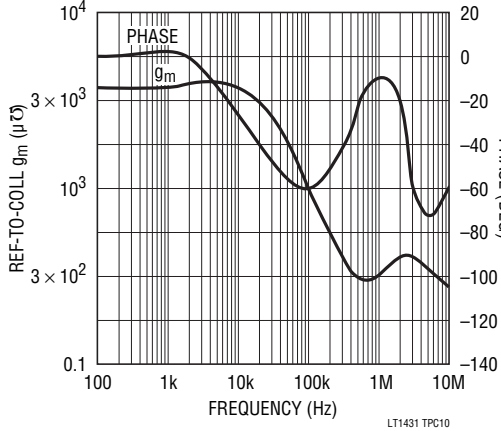

**Dynamic Impedance vs Frequency**

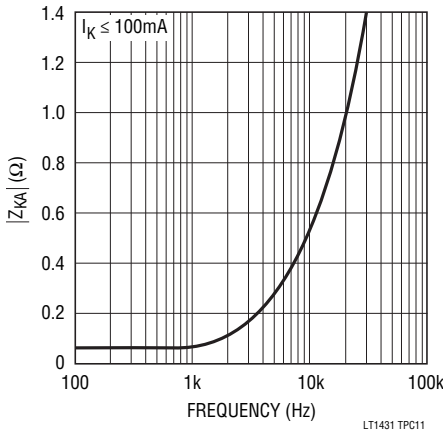

**V<sub>COMP</sub> vs Temperature vs I<sub>COLL</sub>**

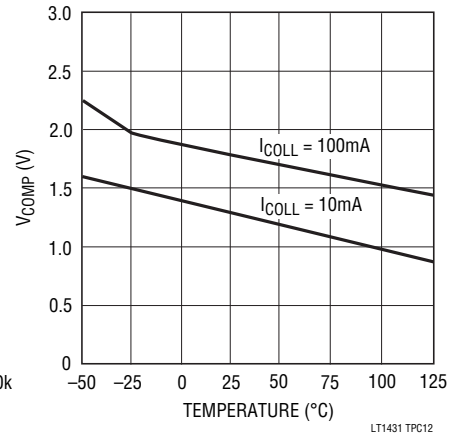

**I<sub>COMP</sub> vs V<sub>COMP</sub> vs V<sub>REF</sub>**

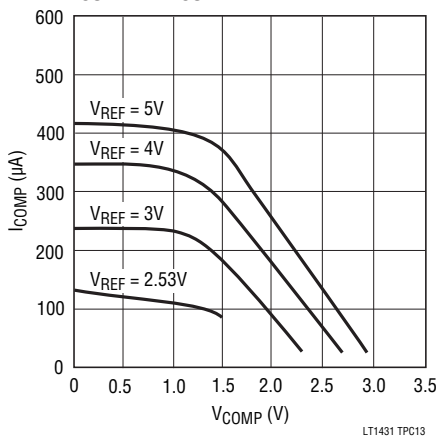

**Noise vs Frequency**

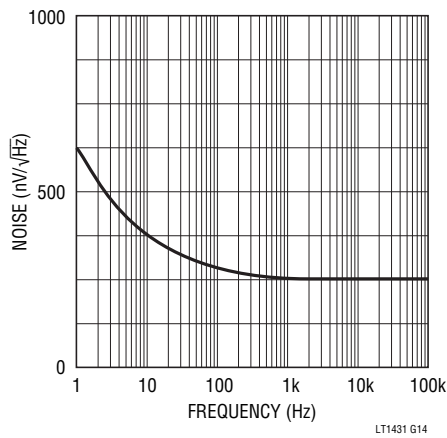

**0.1Hz to 10Hz Noise**

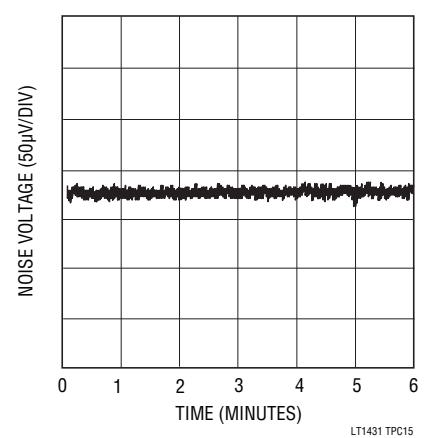

## PIN FUNCTIONS

**COLL (Pin 1):** Open collector of the output transistor. The maximum pin voltage is 36V. The saturation voltage at 100mA is approximately 1V.

**COMP (Pin 2):** Base of the driver for the output transistor. This pin allows additional compensation for complex feedback systems and shutdown of the regulator. It must be left open if unused.

**V<sup>+</sup> (Pin 3):** Bias voltage for the entire shunt regulator. The maximum input voltage is 36V and the minimum to operate is equal to V<sub>REF</sub> (2.5V). The quiescent current is typically 0.6mA.

**R<sub>TOP</sub> (Pin 4):** Top of the on-chip 5k-5k resistive divider that guarantees 1% accuracy of operation as a 5V shunt regulator with no external trim. The pin is tied to COLL for self-contained 5V operation. It may be left open if unused. See note on parasitic diodes below.

**GND-S (Pin 5):** Ground reference for the on-chip resistive divider and shunt regulator circuitry except for the output transistor. This pin allows external current limit of the output transistor with one resistor between GND-F (force) and GND-S (sense).

**GND-F (Pin 6):** Emitter of the output transistor and substrate connection for the die.

**R<sub>MID</sub> (Pin 7):** Middle of the on-chip resistive divider string between R<sub>TOP</sub> and GND-S. The pin is tied to REF for self-contained 5V operation. It may be left open if unused.

**REF (Pin 8):** Control pin of the shunt regulator with a 2.5V threshold. If V<sup>+</sup> > 3V, input bias current cancellation reduces I<sub>B</sub> to 0.2μA typical.

COMP, R<sub>TOP</sub>, R<sub>MID</sub>, and REF have static discharge protection circuits that must not be activated on a continuous basis. Therefore, the absolute maximum DC voltage on these pins is 6V, well beyond the normal operating conditions.

As with all bipolar ICs, the LT1431 contains parasitic diodes which must not be forward biased or else anomalous behavior will result. Pin conditions to be avoided are R<sub>TOP</sub> below R<sub>MID</sub> in voltage and any pin below GND-F in voltage (except for GND-S).

The following pin definitions apply to the Z package.

**CATHODE:** Corresponds to COLL and V<sup>+</sup> tied together.

**ANODE:** Corresponds to GND-S and GND-F tied together.

**REF:** Corresponds to REF.

## BLOCK DIAGRAM

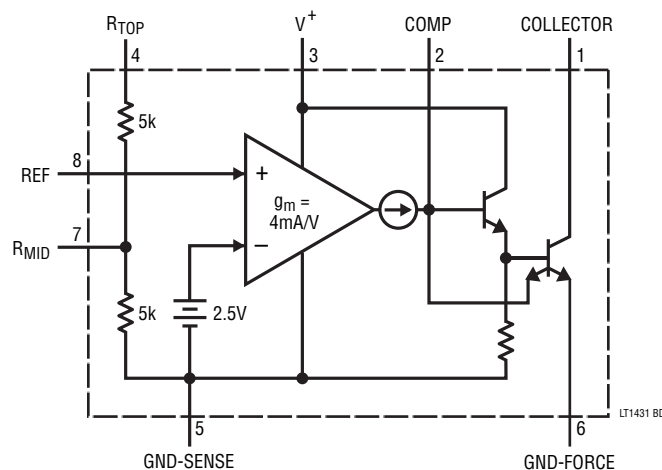

## APPLICATIONS INFORMATION

### Frequency Compensation

As a shunt regulator, the LT1431 is stable for all capacitive loads on the COLL pin. Capacitive loading between 0.01μF and 18μF causes reduced phase margin with some ringing under transient conditions. Output capacitors should not be used arbitrarily because output noise is not necessarily reduced.

Excess capacitance on the REF pin can introduce enough phase shift to induce oscillation when configured as a reference >2.5V. This can be compensated with capacitance between COLL and REF (phase lead). More complicated feedback loops may require shaping of the frequency

response of the LT1431 with dominant pole or pole-zero compensation. This can be accomplished with a capacitor or series resistor and capacitor between COLL and COMP.

The compensation schemes mentioned above use voltage feedback to stabilize the circuits. There must be voltage gain at the COLL pin for them to be effective, so the COLL pin must see a reasonable AC impedance. Capacitive loading of the COLL pin reduces the AC impedance, voltage gain, and frequency response, thereby decreasing the effectiveness of the compensation schemes, but also decreasing their necessity.

## TYPICAL APPLICATIONS

2.5V Reference  
3-Pin Package

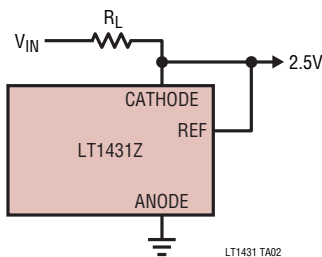

2.5V Reference  
8-Pin Package

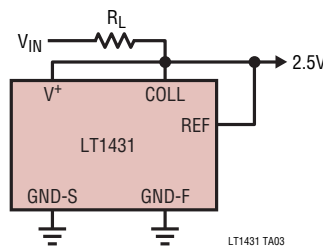

5V Reference

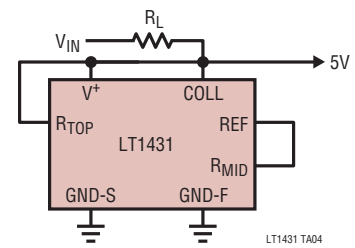

Increasing 5V Reference

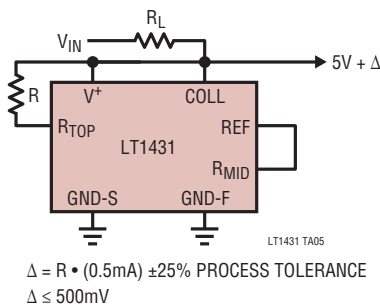

Programmable Reference with Adjustable  
Current Limit

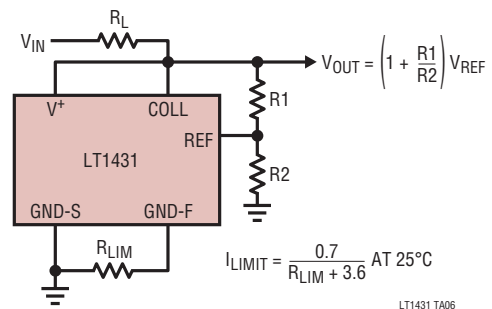

## TYPICAL APPLICATIONS

### PNP Low Dropout 5V Regulator\*

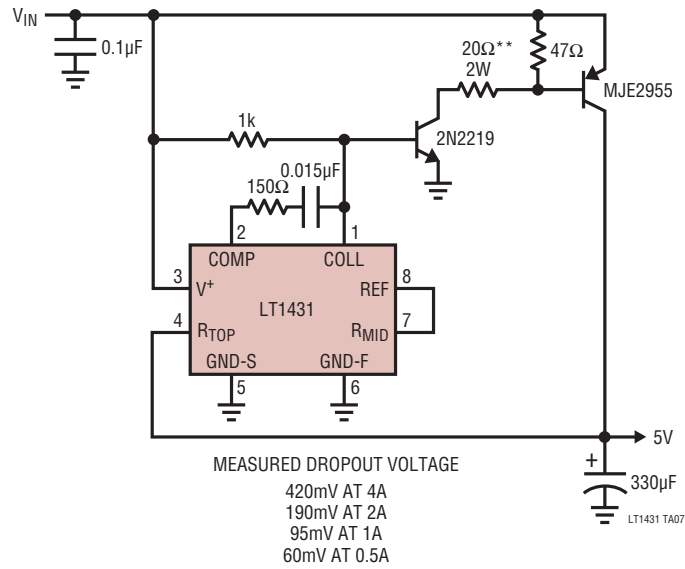

\*NO SHORT-CIRCUIT PROTECTION  
 \*\*MAY BE INCREASED AT LOWER WATTAGE  
 FOR LOWER OUTPUT CURRENTS

### FET Low Dropout 5V Regulator with Current Limit

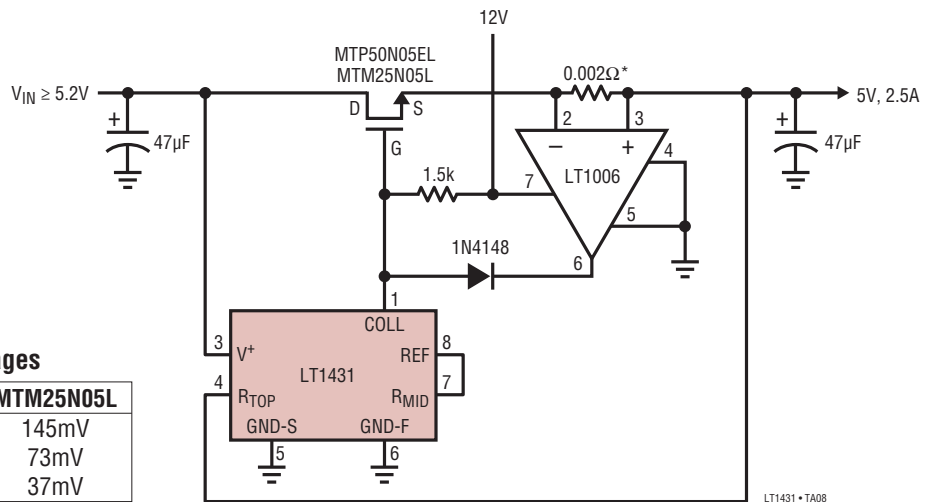

#### Measured Dropout Voltages

I <sub>LOAD</sub>	MTP50N05EL	MTM25N05L
2A	47mV	145mV
1A	22mV	73mV
0.5A	11.5mV	37mV

\*1.5" #23 SOLID COPPER WIRE  
 ~0.002Ω → 3A LIMIT

LT1431 • TA08

# TYPICAL APPLICATIONS

## 12V to 5V Buck Converter with Foldback Current Limit\*

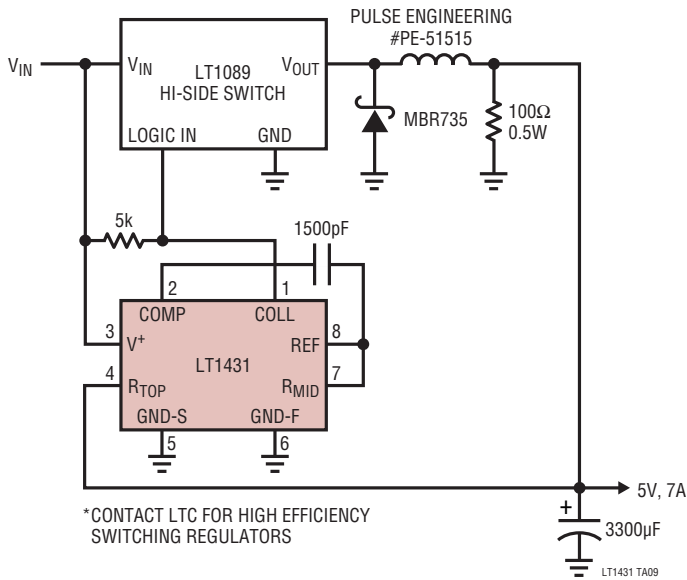

## Buck Converter Efficiency

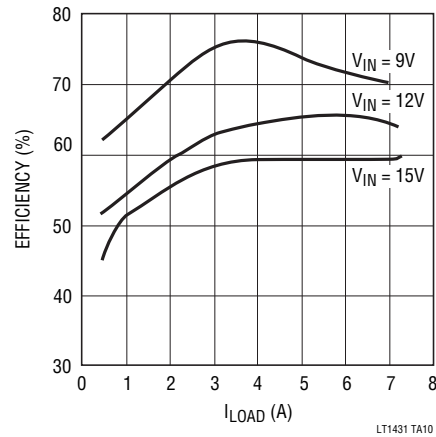

## Isolated 5V to ±15V Flyback Converter

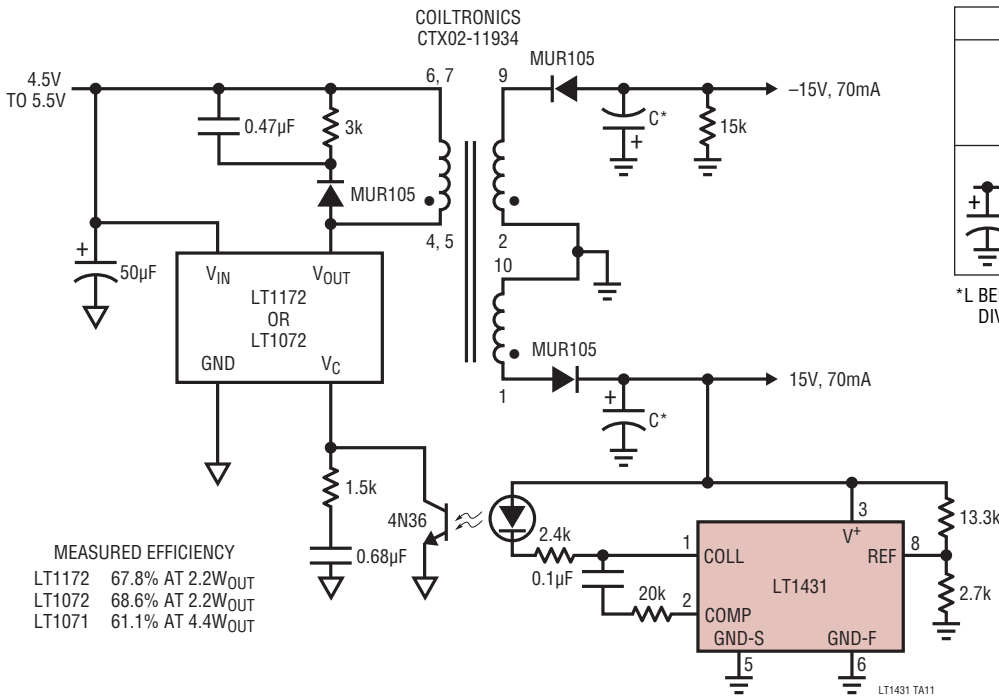

## Fully Loaded Output Ripple vs Filtering

	LT1172	LT1072
<b>C*</b>		
	30mV <sub>p-p</sub>	40mV <sub>p-p</sub>
<b>L*</b>		
	6mV <sub>p-p</sub>	8mV <sub>p-p</sub>

\*L BELL INDUSTRIES J.W. MILLER DIVISION 9310-36 10μH, 450mA

LT1431 TA12

## TYPICAL APPLICATIONS

### 5V Power Supply Monitor with $\pm 500\text{mV}$ Window and 50mV Hysteresis

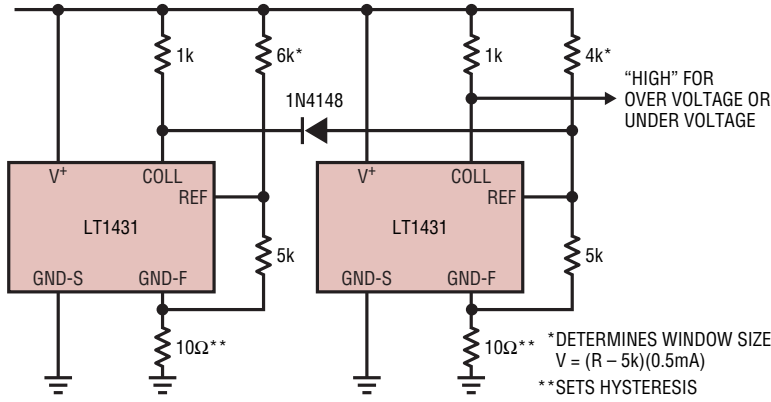

LT1431 TA13

### Transfer Function

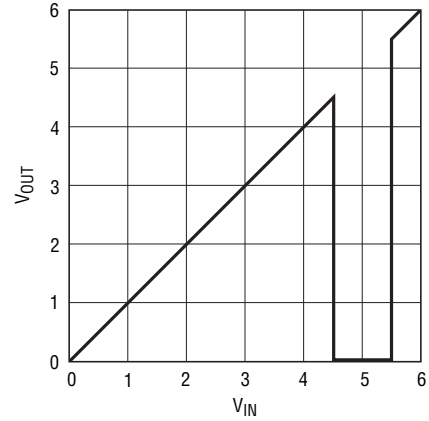

### High Efficiency Buck Converter $E = 85\%$ to $89\%$

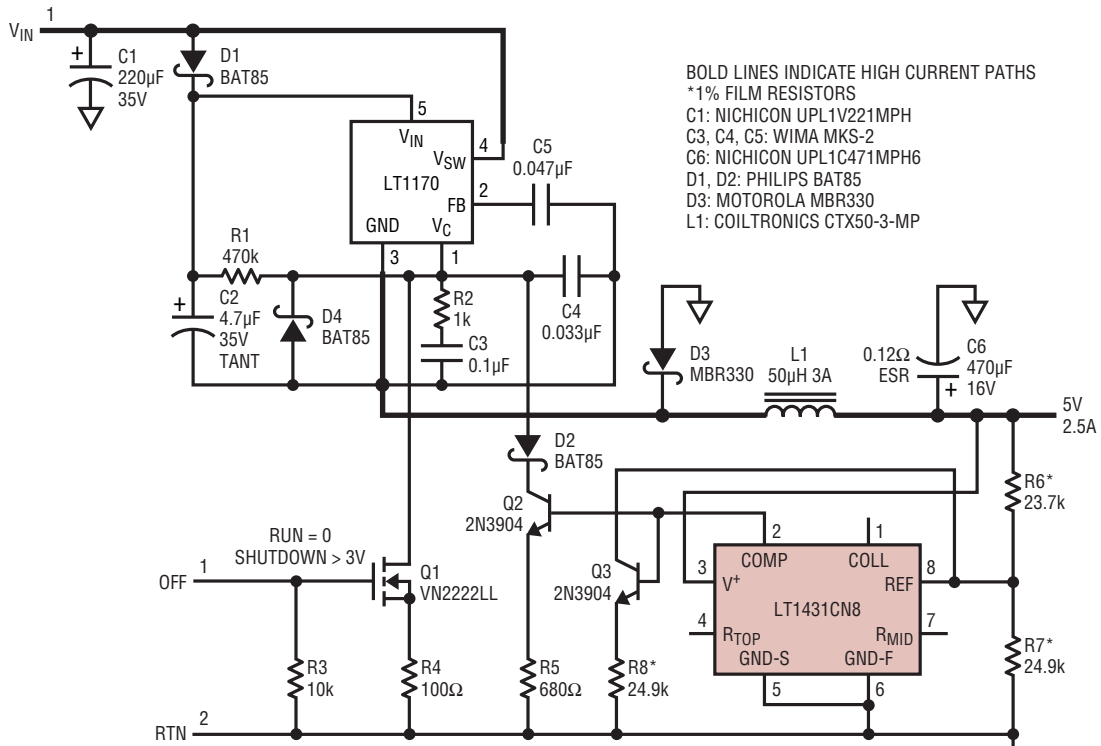

NOTES: UNLESS OTHERWISE SPECIFIED

1. ALL RESISTANCES ARE IN  $\Omega$ , 0.25W, 5%

2. ALL CAPACITANCES ARE IN  $\mu\text{F}$ , 50V, 10%

3. SHUTDOWN LOGIC STATE MUST BE DEFINED BY A LOGIC GATE OR BY TYING TO GND

1431 TA15

# SCHEMATIC DIAGRAM

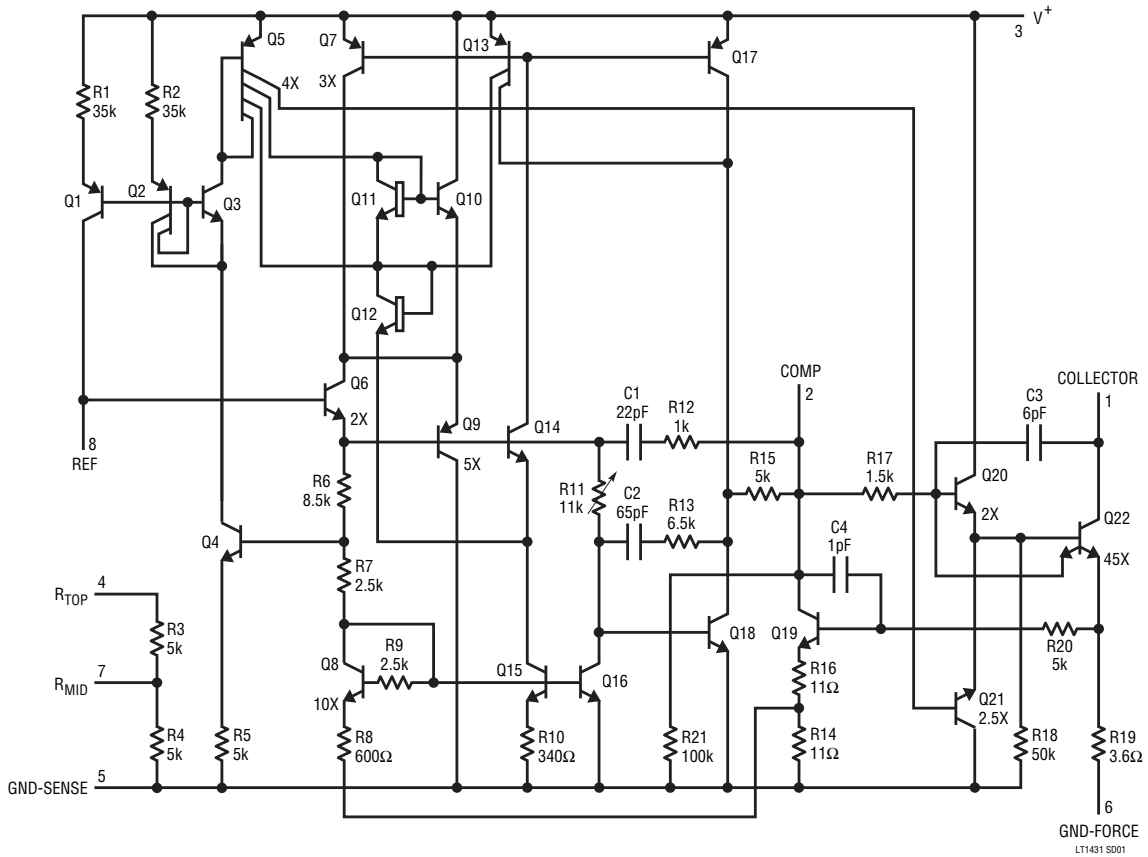

# PACKAGE DESCRIPTION

**J8 Package**  
**8-Lead CERDIP (Narrow .300 Inch, Hermetic)**  
 (Reference LTC DWG # 05-08-1110)

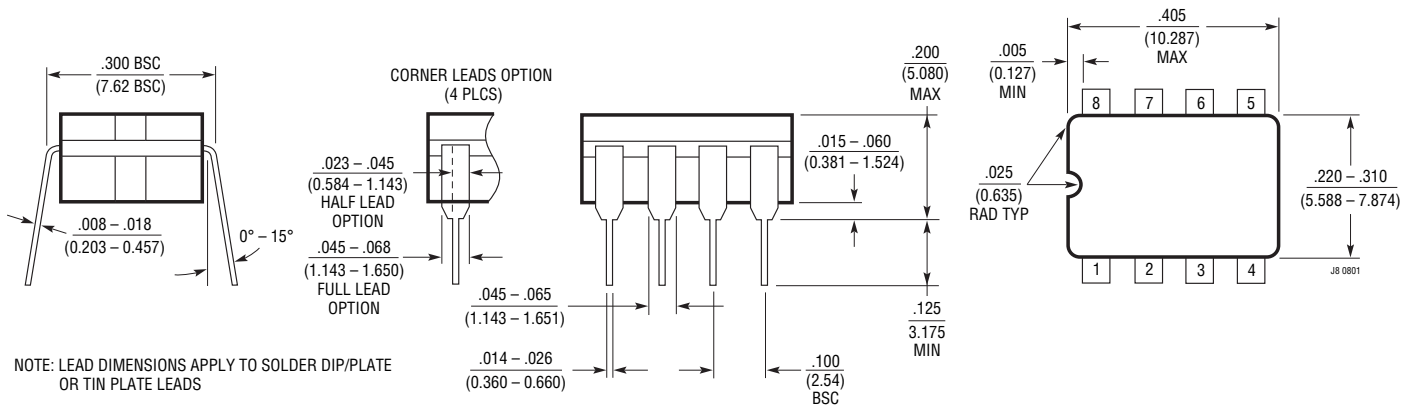

**PACKAGE DESCRIPTION**

**N8 Package**  
**8-Lead PDIP (Narrow .300 Inch)**  
 (Reference LTC DWG # 05-08-1510)

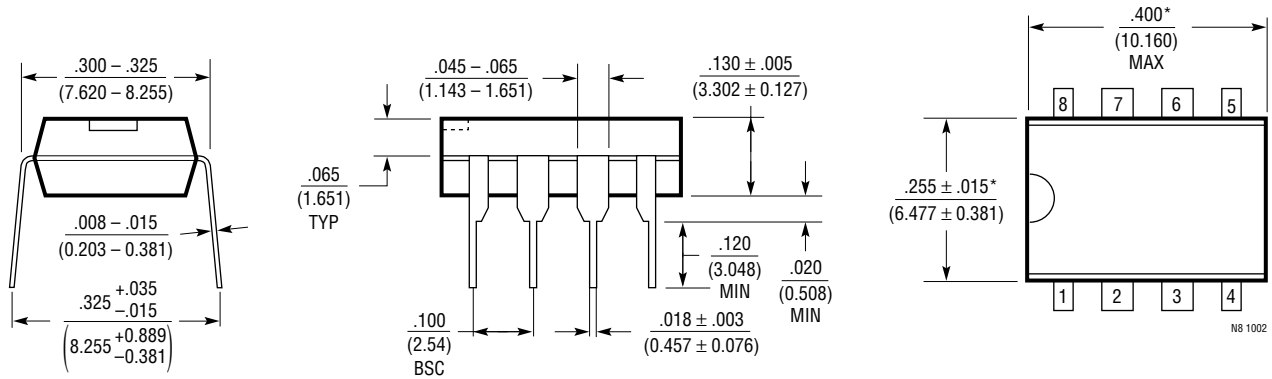

NOTE:  
 1. DIMENSIONS ARE  $\frac{\text{INCHES}}{\text{MILLIMETERS}}$   
 \*THESE DIMENSIONS DO NOT INCLUDE MOLD FLASH OR PROTRUSIONS.  
 MOLD FLASH OR PROTRUSIONS SHALL NOT EXCEED .010 INCH (0.254mm)

**S8 Package**  
**8-Lead Plastic Small Outline (Narrow .150 Inch)**  
 (Reference LTC DWG # 05-08-1610)

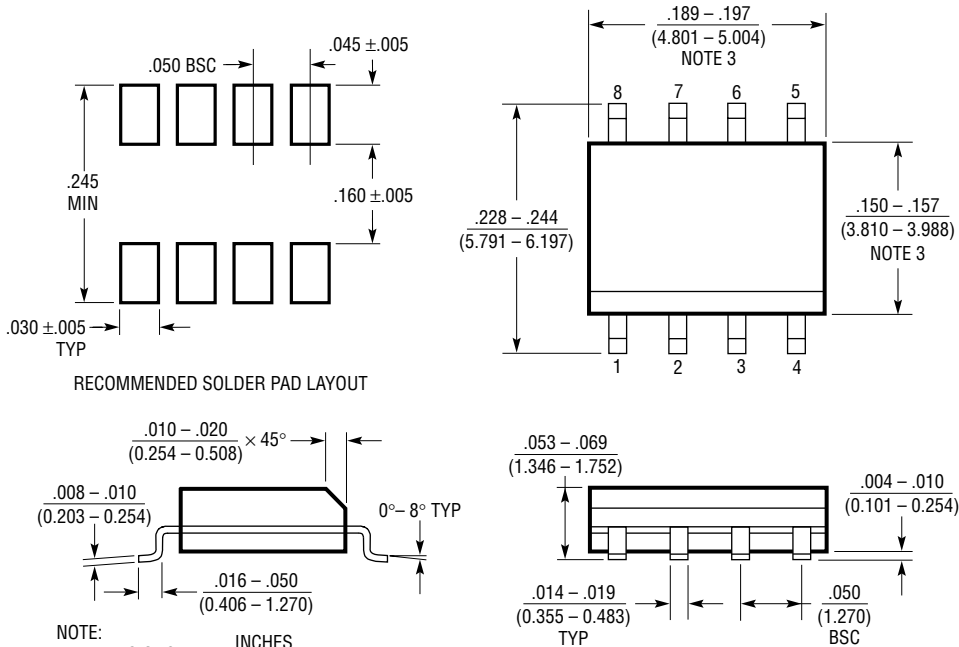

NOTE:  
 1. DIMENSIONS IN  $\frac{\text{INCHES}}{\text{MILLIMETERS}}$   
 2. DRAWING NOT TO SCALE  
 3. THESE DIMENSIONS DO NOT INCLUDE MOLD FLASH OR PROTRUSIONS.  
 MOLD FLASH OR PROTRUSIONS SHALL NOT EXCEED .006" (0.15mm)

S08 0303

**REVISION HISTORY** (Revision history begins at Rev D)

REV	DATE	DESCRIPTION	PAGE NUMBER
D	4/10	M-grade parts re-released. Obsolete package shading removed.	2, 11
E	7/11	Added LT1431MPS8 to data sheet. Changes reflected throughout.	1 to 14

## PACKAGE DESCRIPTION

### Z Package 3-Lead Plastic TO-92 (Similar to TO-226) (Reference LTC DWG # 05-08-1410 Rev C)

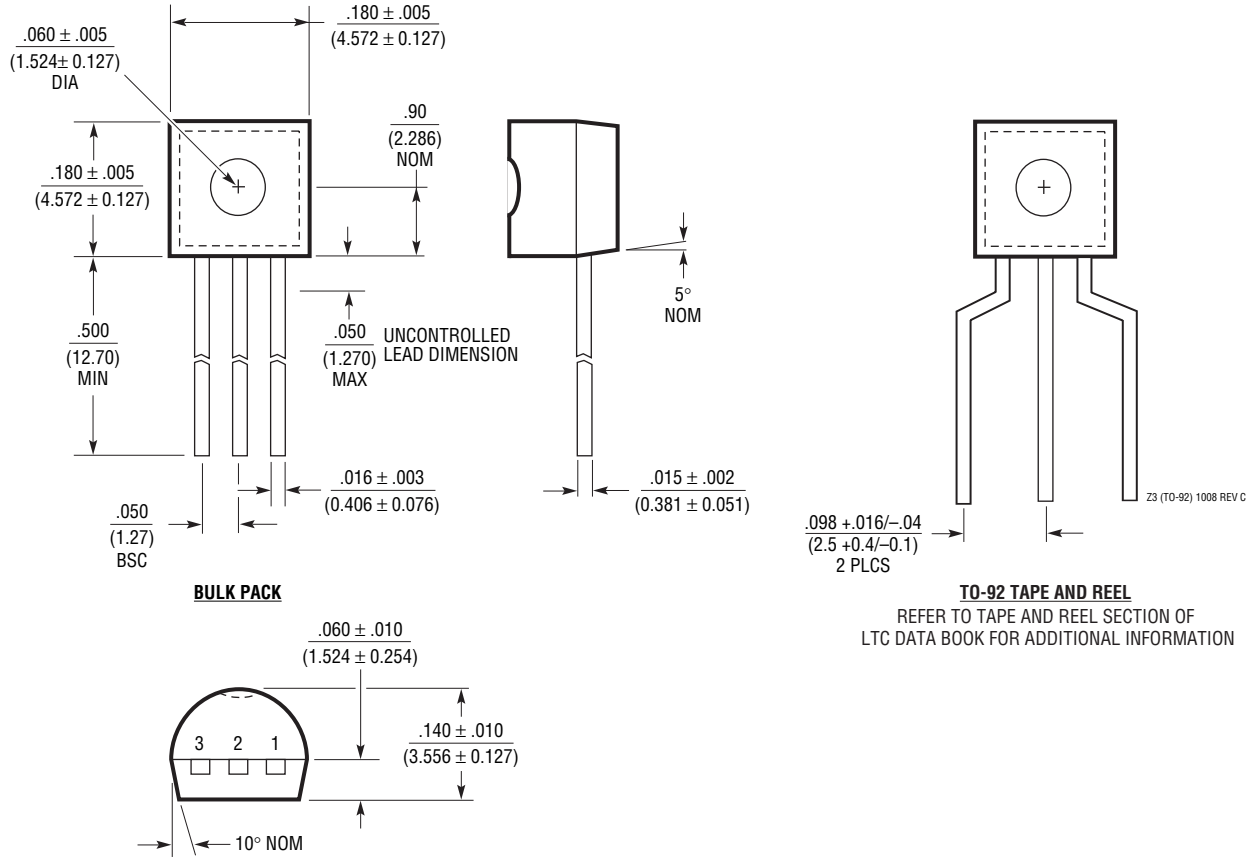

## RELATED PARTS

PART NUMBER	DESCRIPTION	COMMENTS
LT4430	Secondary-Side Optocoupler Driver with Reference Voltage	Overshoot Control Prevents Output Overshoot during Start-Up and Short-Circuit Recovery
LT3757/LT3758	Boost, Flyback, SEPIC and Inverting Controller	2.9V/5.5V ≤ V <sub>IN</sub> ≤ 40V/100V, 100kHz to 1MHz Fixed Frequency, 3mm × 3mm DFN-10 and MSOP-10E Packages
LTC3803/LTC3803-3/ LTC3803-5	Flyback DC/DC Controller with Fixed 200kHz or 300kHz Operating Frequency	V <sub>IN</sub> and V <sub>OUT</sub> Limited by External Components, 6-Pin ThinSOT™ Package
LTC3873/LTC3873-5	No R <sub>SENSE</sub> Constant Frequency Flyback, Boost, SEPIC Controller	V <sub>IN</sub> and V <sub>OUT</sub> Limited Only by External Components, 8-Pin ThinSOT and 2mm × 3mm DFN-8 Packages
LTC3805/LTC3805-5	Adjustable Constant Frequency (70kHz to 700kHz) Frequency Flyback DC/DC Controller	V <sub>IN</sub> and V <sub>OUT</sub> Limited by External Components, MSOP-10E and 3mm × 3mm DFN-10 Packages
LT1952/LT1952-1	Isolated Synchronous Forward Controllers	Ideal for Medium Power 24V and 48V Input Applications
LTC3723-1/LTC3723-2	Synchronous Push-Pull and Full-Bridge Controllers	High Efficiency with On-Chip MOSFET Drivers
LTC3721-1/LTC3721-2	Non-Synchronous Push-Pull and Full-Bridge Controllers	Minimizes External Components, On-Chip MOSFET Drivers
LTC3722/LTC3722-2	Synchronous Isolated Full Bridge Controllers	Ideal for High Power 24V and 48V Input Applications

## Looking for pricing, stock, or lifecycle information?

Click below to explore more details on WIN SOURCE:

 [View LT1431MPS8#PBF on WIN SOURCE](#)

 [Analog Devices Inc. Information](#)

## Optimize Your Supply Chain with WIN SOURCE Solutions

-  Global Sourcing Solution
-  Obsolete Management
-  Cost Control Management
-  Shortage Management
-  Alternative Solution
-  Excess Inventory Management