



THE DATASHEET OF CYONS2100-LBXC



OvationONS™ II Wired Gaming Laser Navigation System on Chip

Features

- Programmable Blocks
 - Highly integrated mouse-on-a-chip with programmable PSoC® MCU
 - 32K Byte Flash memory
 - 2K Byte SRAM memory
 - Internal 24, 12, or 6 MHz main oscillator
 - Internal 32 kHz low speed oscillator
 - 16 bit data report enables high speed and high resolution
- Tracking Performance
 - Continuously variable resolution: 400 to 3200 cpi independent of speed
 - High speed with high accuracy tracking
 - Speed up to 75 in/s
 - Acceleration up to 30G
- Peripheral interface
 - Integrated full speed USB for wired applications
 - SPI master for interface to external functions
 - Up to 28 general purpose IO pins
 - I²C
- Power
 - Internal power system enables operation from 5V USB or 2.7 to 3.6V external supply
 - Self adjusting power saving modes
- On-Chip Laser
 - Vertical Cavity Surface Emitting Laser (VCSEL) integrated within the sensor package
 - No calibration or alignment needed
 - ESD immunity: 2000V (human body model)
 - Wavelength: 850 nm Typ (840 nm min, 870 nm max)
 - Class 1 Safety: built in TUC compliant eye safety fault tolerant laser drive circuitry
- Snap On Lens
 - Molded Optic: Self aligning snap on molded lens
 - 6 mm distance between the PCB and tracking surface

Description

The CYONS2100 is a member of Cypress Semiconductor's second generation laser navigation SoC family of products. Powered by the high speed and high precision OptiCheck™ technology, along with the world leading PSoC technology, this family integrates the sensor, USB, and MCU functions into one chip. Bundled with the Vertical Cavity Surface Emitting Laser (VCSEL) into one package, the combination forms the market's first true Mouse-on-a-Chip solution.

The CYONS2100 is the version that is designed for high performance gaming applications. Enabled by the Cypress 0.13 micron mixed signal process technology, the device integrates the OptiCheck sensor with full speed USB into a single silicon chip that enables seamless communication between sensor and MCU/Full Speed USB. The sensor provides the best translation of hand motion into true gaming motion on PC.

This highly integrated solution is programmable. It provides mouse suppliers the ease of use to design a single PCB system and customize their product. With the VCSEL integrated in the same package, designers do not need to calibrate the laser power during the manufacturing process. This greatly increases production throughput and reduces manufacturing costs.

The innovative technology of OvationONS™ II provides high precision, high speed motion tracking, and low power consumption. Designers can select from a family of integration options, ranging from low power to high performance, to target different types of wired and wireless design applications.

The CYONS2100 solutions have a small form factor. Along with the lens, each package forms a complete and compact laser tracking system. This data sheet describes the detailed technology capabilities of the CYONS2100.

Figure 1. CYONS2100/CYONSLENS2000 (2-Piece System)

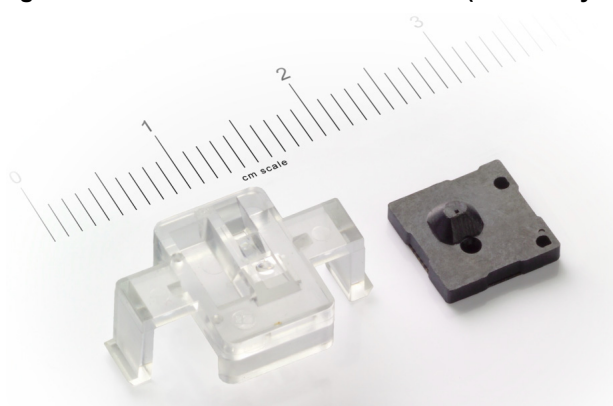

OvationONS II Family Performance Table

Parameter	CYONS2000	CYONS2001	CYONS2100	CYONS2101	CYONS2110	Unit
Variable resolution	400, 800, 1600	400, 800, 1600	400–3200	400–3200	400–3200	cpi
Maximum speed	30	30	75	75	75	in/s
Maximum acceleration	20	20	30	30	30	G
Integrated MCU	Yes	Yes	Yes	Yes	Yes	
CapSense	No	No	No	No	26 inputs	
Flash	16K	16K	32K	32K	32K	Byte
SRAM	2K	2K	2K	2K	2K	Byte
Interfaces	Full speed USB 4 wire SPI up to 28 GPIOs	4 wire SPI up to 28 GPIOs	Full speed USB 4 wire SPI up to 28 GPIO	4 wire SPI up to 28 GPIOs	Full speed USB 4 wire SPI up to 28 GPIOs	
Battery supply voltage	NA	0.8 - 3.6	NA	0.8 to 3.6	0.8 to 3.6	V
USB supply voltage	4.25 to 5.25	NA	4.25 to 5.25	NA	4.25 to 5.25	V
External supply voltage	2.7 - 3.6	2.7 - 3.6	2.7 - 3.6	2.7 - 3.6	2.7 - 3.6	V
Zero motion	1	1	1	1	1	count

OvationONS II Family Applications

- Wired and wireless laser mice
 - Gaming, graphic design, desktop, and mobile mice
- Optical trackballs
- Battery powered devices
- Motion sensing applications

OvationONS II Family Functional Description

The OvationONS II family is a two-piece laser navigation system on chip (SoC) kit containing the integrated IC package and the molded lens.

The 2 kV ESD rated IC package integrates the VCSEL and laser sensor SoC. Depending on the product selected, the SoC includes a microcontroller unit (MCU), Flash, SRAM, internal oscillator, CapSense system, battery boost regulator, power regulator, and full speed USB.

The molded lens collimates the VCSEL beam and images the light scattered from the tracking surface on to the sensor portion of the laser detector. The lens has features for registration to the package and easily snaps on to the PC board.

At the heart of the system is the OptiCheck laser navigation engine. It supports all functions required for tracking, including laser power control, resolution control, and self-adjusting power reduction, which reduces power consumption when motion stops. The laser output power is pre-calibrated to meet the eye safety requirements of IEC 60825 Class 1.

The navigation engine is accessed and controlled by an integrated PSoC-based MCU. The interface between the two blocks is through a system bus and a collection of navigation

engine interrupts. Full details are available in the Technical Reference Manual.

In addition to controlling the navigation engine, the PSoC MCU also serves as the main application processor. Based on Cypress's M8C architecture, the PSoC supports a rich instruction set, multiple processor speeds, flexible general purpose IOs (GPIOs). Its internal oscillator requires no external crystal. On-chip Flash and RAM enable entire navigation systems to be implemented with the single SoC.

The OvationONS II Family supports a wide range of powering options. Internal regulators minimize the need for external circuitry. Depending on the product selected, the device can be powered from USB's 5V supply, from a single battery, from dual batteries, or from an external supply. The configuration and use of the power blocks are controlled with the integrated PSoC.

Wired sensors include integrated full speed USB. As with the navigation engine and power system, the USB block is controlled by the integrated PSoC.

All sensors support a 4-wire SPI interface. A typical use of the SPI interface is to provide access to a radio for wireless applications.

The CYONS2110 device also supports CapSense functions, enabling additional features and differentiation in end products.

All features of the OvationONS II family are configured using Cypress's PSoC Designer™ software, enabling fast application development and time to market.

The OvationONS II family block diagram is shown in [Figure 2](#). It shows a true System-on-a-Chip solution that enables design cycle reductions along with savings on manufacturing, PCB area, and component inventory management. The packaged solution delivers a fully integrated system that demonstrates tracking performance with efficient power consumption.

Figure 2. Block Diagram

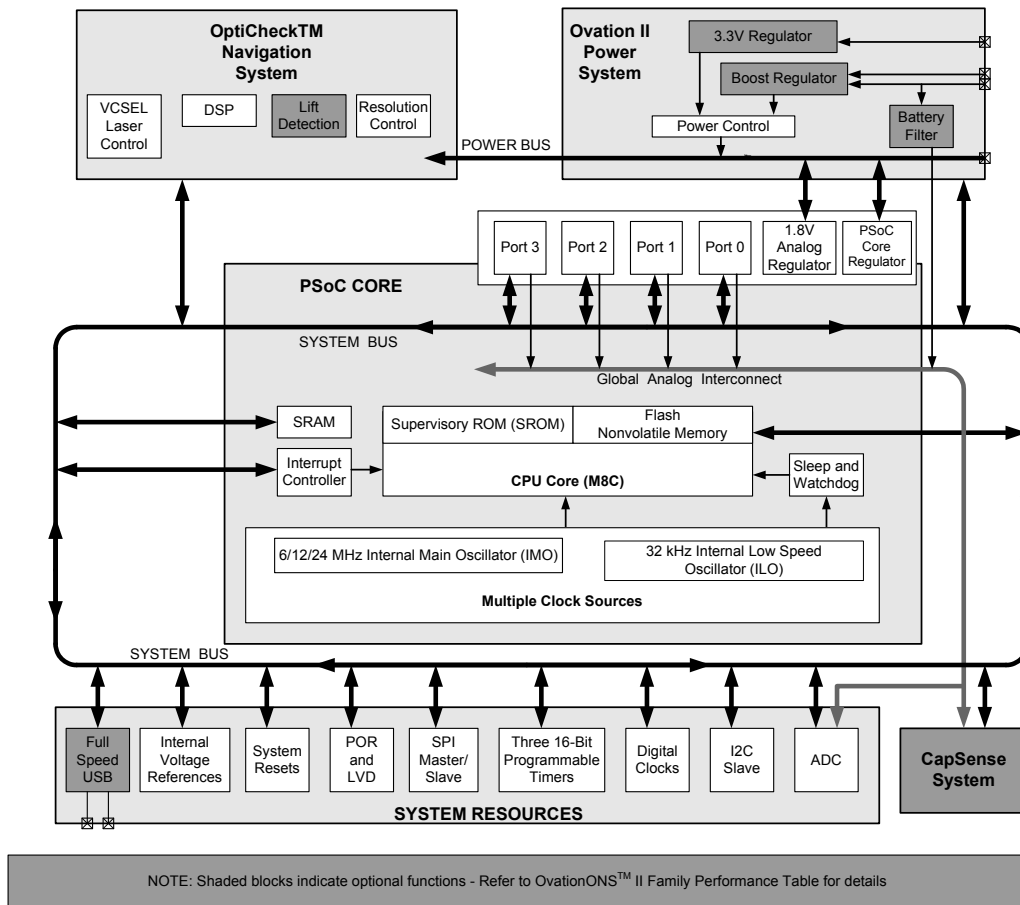

Pin Descriptions

This section describes, lists, and illustrates the CYONS2100 device pins and pinout configurations. The CYONS2100 is available in a 42-pin QFN package.

Table 1. CYONS2100 Pin Descriptions

Pin ^[1]	Name	Digital	Analog	Description
1	XRES	I		Active high external reset with internal pull down
2	DVSS	Power	Power	Digital ground
3	DNU			Do not use
4	DVSS	Power	Power	Digital ground
5	DVDD	Power	Power	Digital supply voltage and regulated output (see page 10)
6	VREGD	Power	Power	Digital VREG
7	AVDD	Power	Power	Analog supply voltage
8	VREGA	Power	Power	Analog VREG
9	P2[7]	IO	I	GPIO
10	P1[5]	IOHR	I	SPI MISO, GPIO
11	P1[3]	IOHR	I	SPI CLK, GPIO
12	P2[3]	IO	I	GPIO
13	P2[5]	IO	I	GPIO

Table 1. CYONS2100 Pin Descriptions (continued)

Pin ^[1]	Name	Digital	Analog	Description
14	P1[7]	IOHR	I	SPI SS, GPIO
15	P1[1]	IOHR	I	SPI MOSI, ISSP CLK ⁽¹⁾ , GPIO
16	P3[3]	IOHR	I	HCLK (OCD high speed clock output), GPIO
17	P1[0]	IO	I	ISSP DATA ⁽¹⁾ , GPIO
18	P3[5]	IO	I	CCLK (OCD CPU clock output), GPIO
19	P1[6]	IOHR	I	GPIO
20	P1[2]	IOHR	I	GPIO
21	P2[2]	IO	I	GPIO
22	P3[7]	IO	I	OCDOE (OCD mode direction pin), GPIO
23	P3[1]	IO	I	OCDO (OCD odd data output), GPIO
24	OCDE	OCD	OCD	OCDE (OCD even data output)
25	AVSS	Power	Power	Analog ground
26	P2[1]	IO	I	GPIO
27	P2[0]	IO	I	GPIO
28	P1[4]	IOHR	I	EXT CLK, GPIO
29	P2[4]	IO	I	GPIO
30	DVSS	Power	Power	Digital ground
31	P2[6]	IO	I	GPIO
32	P0[0]	IO	I	GPIO
33	P0[2]	IO	I	GPIO
34	P0[4]	IO	I	GPIO
35	P0[6]	IO	I	GPIO
36	P0[1]	IO	I	GPIO
37	P0[3]	IO	I	GPIO
38	P0[5]	IO	I	GPIO
39	P0[7]	IO	I	GPIO
40	D-	IO		USB data
41	D+	IO		USB data
42	VDD5V	Power	Power	5V power
CP	DVSS	Power	Power	Center pad must be connected to digital ground

Legend: I=Input; O=Output; H=5 mA High Output Drive, R=Regulated Output, OCD=On-Chip Debug

Note

1. These are the ISSP pins, which are not High Z at POR (Power On Reset)

Figure 3. Pin Diagram

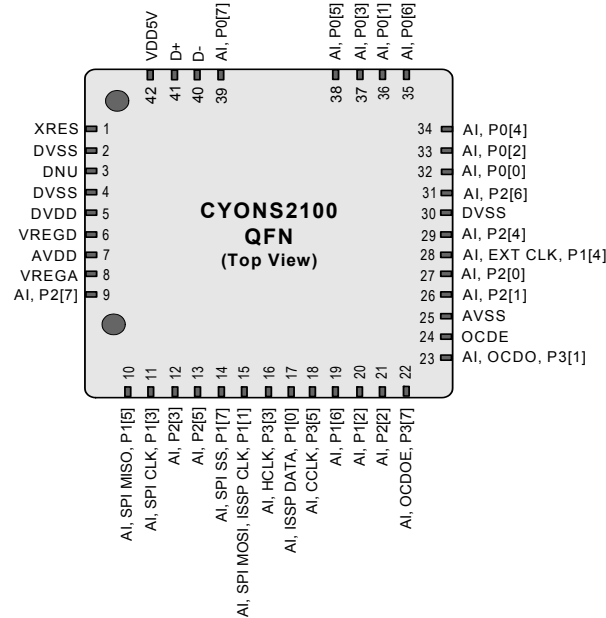

Microcontroller System

Features

- Powerful Harvard Architecture processor
 - M8C processor speed up to 24 MHz
 - Low power at high speed
 - Interrupt controller
 - Operating temperature range: +5°C to +45°C
- Flexible on-chip memory
 - 32K flash program storage
50,000 erase and write cycles
 - 2K bytes SRAM data storage
 - Partial flash updates
 - Flexible protection modes
 - In-System Serial Programming (ISSP)
- Full speed USB (12 Mbps)
 - Eight unidirectional endpoints
 - One bidirectional control endpoint
 - USB 2.0 Compliant
 - Dedicated 512 byte buffer
 - Internal 3.3V output regulator
- Complete development tools
 - Free development tool (PSoC Designer)
 - Full featured In-Circuit Emulator and programmer
 - Full speed emulation
 - Complex breakpoint structure
 - 128K trace memory
- Precision programmable clocking
 - Internal ±5.0% 6, 12, or 24 MHz main oscillator
 - Internal low speed oscillator at 32 kHz for watchdog and sleep
 - Support for optional external 32 kHz crystal
 - 0.25% accuracy for USB with no external crystal
- Programmable pin configurations
 - 25 mA sink current on all GPIO
 - Pull Up, High-Z, Open Drain drive modes on all GPIO
 - CMOS drive mode on ports 0 and 1
 - Up to 28 analog inputs on GPIO
 - Configurable inputs on all GPIO
 - Selectable, regulated Digital IO on port 1
 - 3.0V, 20 mA total port 1 source current
 - 5 mA source current mode on ports 0 and 1
 - Hot swap capable
- Versatile analog mux
 - Common internal analog bus
 - Simultaneous connection of IO combinations
 - High PSRR comparator
 - Low dropout voltage regulator for the analog array
- Additional system resources
 - SPI Master and SPI Slave
 - Configurable between 46.9 kHz and 3 MHz
 - Three 16-bit timers
 - Watchdog and Sleep timers
 - Internal voltage reference
 - Integrated supervisory circuit
 - Analog to digital converter
 - I²C Slave

PSoC Functional Overview

Cypress's Programmable System-on-Chip (PSoC) Mixed-Signal Arrays combine dynamic, configurable analog and digital blocks and an 8-bit MCU on a single chip, replacing multiple discrete components while delivering advanced flexibility and functionality. A PSoC device includes configurable analog and digital blocks, and programmable interconnect. This architecture enables the creation of customized peripheral configurations, to match the requirements of each individual application. Additionally, a fast CPU, Flash program memory, SRAM data memory, and configurable IO are included in a range of convenient pinouts.

The architecture for this device family, as illustrated in [Figure 2](#) on page 3, contains: the core, the navigation sensor, the power system, and the system resources (including a full speed USB port). A common, versatile bus enables connection between IO and the analog system. A GPIO, which provides access to the MCU and analog mux, is also included.

The PSoC Core

The PSoC core is a powerful engine that supports a rich instruction set. The PSoC core encompasses SRAM for data storage, an interrupt controller, Sleep and Watchdog timers, an IMO (Internal Main Oscillator), and an ILO (Internal Low Speed Oscillator). The CPU core, called the M8C, is a powerful processor with speeds up to 24 MHz. The M8C is a 4 MIPS, 8-bit Harvard architecture microprocessor.

System resources provide additional capability, such as configurable USB and SPI master-slave communication interface, three 16-bit programmable timers, and various system resets supported by the M8C.

The Analog Multiplexer System

The analog mux bus connects to every GPIO pin. Pins are connected to the bus individually or in any combination. Analog signals may be routed to an internal analog-to-digital converter.

Other multiplexer applications include:

- Chip-wide mux that enables analog input from any IO pin
- Crosspoint connection between any IO pin combinations

Additional System Resources

System resources, some previously listed, provide additional capability useful to complete systems. Additional resources include low voltage detection and power on reset. The following statements describe the merits of each system resource:

- The SPI master/slave module
 - Provides communication over three or four wires
 - Runs at speeds of 46.9 kHz to 3 MHz (lower for a slower system clock).
- An I²C slave module
- Low Voltage Detection (LVD) interrupts can signal the application of falling voltage levels, while the advanced POR (Power On Reset) circuit eliminates the need for a system supervisor.
- An internal reference provides an absolute reference for capacitive sensing.

Getting Started

The quickest path to understanding the Laser Sensor and PSoC silicon is to read this data sheet and use the PSoC Designer Integrated Development Environment (IDE).

Reference Design Kits

Reference design kits are available from Cypress. Contact your sales representative for information.

Technical Training Modules

Free PSoC technical training modules are available for users new to PSoC. Training modules cover designing, debugging, and advanced analog. Go to <http://www.cypress.com/techtrain>.

Application Notes

A long list of application notes assist you in every aspect of your design effort. To view the PSoC application notes, go to <http://www.cypress.com> and select Application Notes under the Documentation list located in the top right of the web page. Application notes are sorted by date by default.

Development Tools

PSoC Designer is a Microsoft Windows[®] based integrated development environment for the Programmable System-on-Chip[™] (PSoC) devices. The PSoC Designer IDE and application runs on the Windows NT[®] 4.0, Windows 2000, Windows Millennium (Me), Windows XP, or Windows Vista[™] operating systems. (Refer to PSoC Designer Functional Flow diagram in [Figure 4](#) on page 7.)

PSoC Designer helps the customer select an operating configuration for the USB, navigation, and power modules, write application code, and debug the application. This system provides design database management by project, an integrated debugger with In-Circuit Emulator (ICE), in-system programming support, and the CYASM macro assembler for the CPUs.

PSoC Designer also supports a high level C language compiler developed specifically for the devices in the family.

Figure 4. PSoC Designer Subsystems

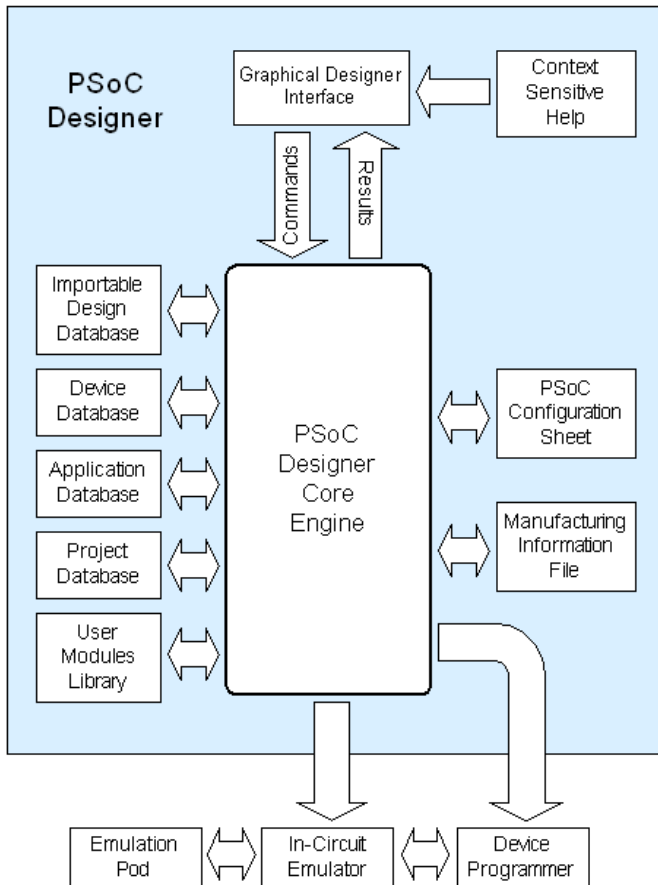

PSoC Designer Software Subsystems

Device Editor

The device editor subsystem enables the selection of different onboard analog and digital components, called user modules, using the CYONS2100 device blocks. Examples of user modules are timers, SPI, and so on.

The device editor also supports easy development of multiple configurations and dynamic reconfiguration. Dynamic reconfiguration enables changing configurations at run time.

PSoC Designer sets up power on initialization tables for selected CYONS2100 block configurations and creates source code for an application framework. The framework contains software to operate the selected components and, if the project uses more than one operating configuration, contains routines to switch between different sets of CYONS2100 block configurations at run time. PSoC Designer can print a configuration sheet for a supplied project configuration for use during application programming in conjunction with the device data sheet. After the framework is generated, the user adds application specific code to complete the framework. It is also possible to change the selected components and regenerate the framework.

Application Editor

In the Application Editor, edit the C language and Assembly language source code. You can also assemble, compile, link, and build.

Assembler

The macro assembler enables the assembly code to merge seamlessly with C code. The link libraries automatically use absolute addressing or compile in relative mode, and link with other software modules to get absolute addressing.

C Language Compiler

A C language compiler supporting the CYONS2100 family of devices is available. Even if you have never worked in the C language before, the product quickly enables you to create complete C programs for the CYONS2100 family devices.

The embedded, optimizing C compiler provides all the features of C tailored to the CYONS2100 architecture. It comes complete with embedded libraries providing port and bus operations, standard keypad and display support, and extended math functionality.

Debugger

The PSoC Designer Debugger subsystem provides hardware in-circuit emulation, enabling the designer to test the program in a physical system while providing an internal view of the PSoC device. Debugger commands enable the designer to

- Read the program
- Read and write data memory
- Read and write IO registers
- Read and write CPU registers
- Set and clear breakpoints
- Provide program run, halt, and step control

The debugger also enables the designer to create a trace buffer of registers and memory locations of interest.

Online Help System

The online help system displays online, context sensitive help. Designed for procedural and quick reference, each functional subsystem has its own context sensitive help. This system also provides tutorials and links to FAQs and an Online Support Forum to aid the designer in getting started.

Hardware Tools

In-Circuit Emulator (ICE)

A low cost, high functionality ICE is available for development support. This hardware can program single devices.

Designing with User Modules

The development process for the PSoC device differs from that of a traditional fixed function microprocessor. The configurable analog and digital hardware blocks give the PSoC architecture a unique flexibility that pays dividends in managing specification change during development and by lowering inventory costs. These configurable resources, called PSoC Blocks, can implement a wide variety of user-selectable functions. Each

block has several registers that determine its function and connectivity to other blocks, multiplexers, buses and to the IO pins. Iterative development cycles permit you to adapt the hardware and the software. This substantially lowers the risk of having to select a different part to meet the final design requirements.

To speed the development process, the PSoC Designer IDE provides a library of prebuilt, pretested hardware peripheral functions, called user modules. User modules simplify selecting and implementing peripheral devices and come in analog, digital, and mixed signal varieties.

Each user module establishes the basic register settings that implement the selected function. It also provides parameters that enable you to tailor its precise configuration to your particular application. User modules also provide tested software to cut your development time. The user module application programming interface (API) provides high level functions to control and respond to hardware events at run time. The API also provides optional interrupt service routines that you can adapt.

The API functions are documented in user module data sheets that are viewed directly in the PSoC Designer IDE. These data sheets explain the internal operation of the user module and provide performance specifications. Each data sheet describes the use of each user module parameter and documents the setting of each register controlled by the user module.

The development process starts when you open a new project and bring up the Device Editor, a graphical user interface (GUI) for configuring the hardware. You must pick and place the user modules that you need for the project. The tool automatically builds signal chains by connecting user modules to the default IO pins or as required. At this stage, you can also configure the clock source connections and enter parameter values directly or by selecting values from drop down menus. When you are ready to test the hardware configuration or move on to developing code for the project, perform the "Generate Application" step. This causes PSoC Designer to generate source code that automatically configures the device to your specification and provides the high-level user module API functions.

Figure 5. User Module and Source Code Development Flows

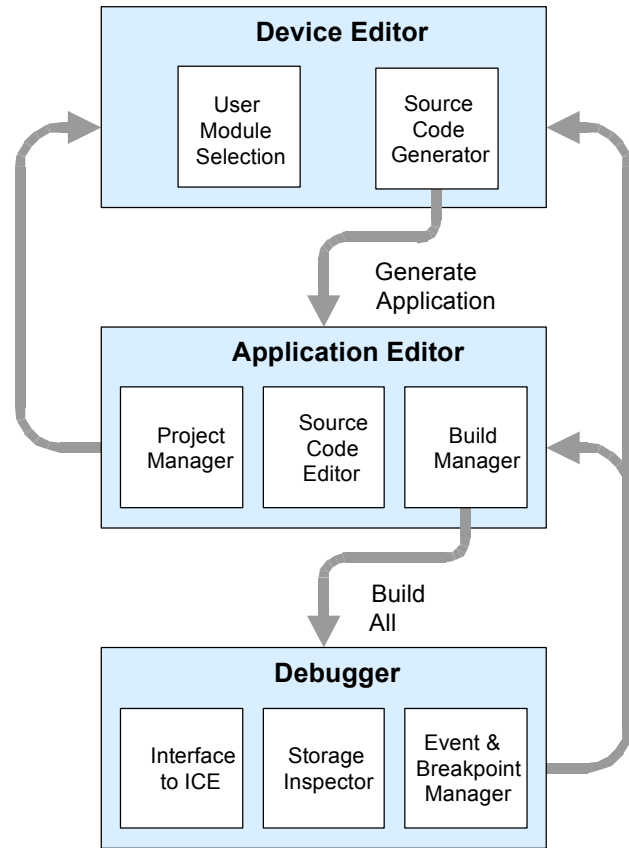

The next step is to write your main program, and any subroutines using PSoC Designer’s Application Editor subsystem. The Application Editor includes a Project Manager that enables you to open the project source code files (including all generated code files) from a hierarchal view. The source code editor provides syntax coloring and advanced edit features for both C and assembly language. File search capabilities include simple string searches and recursive “grep style” patterns. A single mouse click invokes the Build Manager. It employs a professional strength “makefile” system to automatically analyze all file dependencies and run the compiler and assembler as necessary. Project level options control optimization strategies used by the compiler and linker. Syntax errors are displayed in a console window. Double clicking the error message takes you directly to the offending line of source code. When all is correct, the linker builds a HEX file image suitable for programming.

The last step in the development process takes place inside the PSoC Designer Debugger subsystem. The Debugger downloads the HEX image to the ICE where it runs at full speed. Debugger capabilities rival those of systems costing many times more. In addition to traditional single step, run-to-breakpoint and watch variable features, the Debugger provides a large trace buffer and enables you to define complex breakpoint events that include monitoring address and data bus values, memory locations, and external signals.

Document Conventions

Acronyms Used

Table 2 lists the acronyms used in this document.

Units of Measure

The units of measure in Table 3 lists the abbreviations used to measure the devices.

Numeric Naming

Hexadecimal numbers are represented with all letters in uppercase with an appended lowercase 'h' (for example, '14h' or '3Ah'). Hexadecimal numbers may also be represented by a '0x' prefix, the C coding convention. Binary numbers have an appended lowercase 'b' (for example, '01010100b' or '01000011b'). Numbers not indicated by an 'h', 'b', or 0x are decimal.

Table 2. Acronyms

Acronym	Description	Acronym	Description
AC	Alternating Current	IO	Input/output
API	Application Programming Interface	LSb	Least-significant Bit
CPU	Central Processing Unit	LVD	Low Voltage Detect
DC	Direct Current	MSb	Most-significant Bit
GPIO	General Purpose IO	POR	Power On Reset
GUI	Graphical User Interface	PPOR	Precision Power On Reset
ICE	In-circuit Emulator	PSoC®	Programmable System-on-chip™
ILO	Internal Low Speed Oscillator	SLIMO	Slow IMO
IMO	Internal Main Oscillator	SRAM	Static Random Access Memory

Table 3. Units of Measure

This table lists the units of measure used in this section

Symbol	Unit of Measure	Symbol	Unit of Measure
°C	degree Celsius	μW	microwatt
dB	decibel	mA	milliampere
fF	femtofarad	ms	millisecond
Hz	hertz	mV	millivolt
KB	1024 bytes	nA	nanoampere
Kbit	1024 bits	ns	nanosecond
kHz	kilohertz	nV	nanovolt
kΩ	kilohm	W	ohm
MHz	megahertz	pA	picoampere
MΩ	megaohm	pF	picofarad
μA	microampere	pp	peak-to-peak
μF	microfarad	ppm	parts per million
μH	microhenry	ps	picosecond
μs	microsecond	sps	samples per second
μV	microvolts	s	sigma: one standard deviation
μVrms	microvolts root-mean-square	V	volt

Power Supply Connections

Figure 6. Power Connections

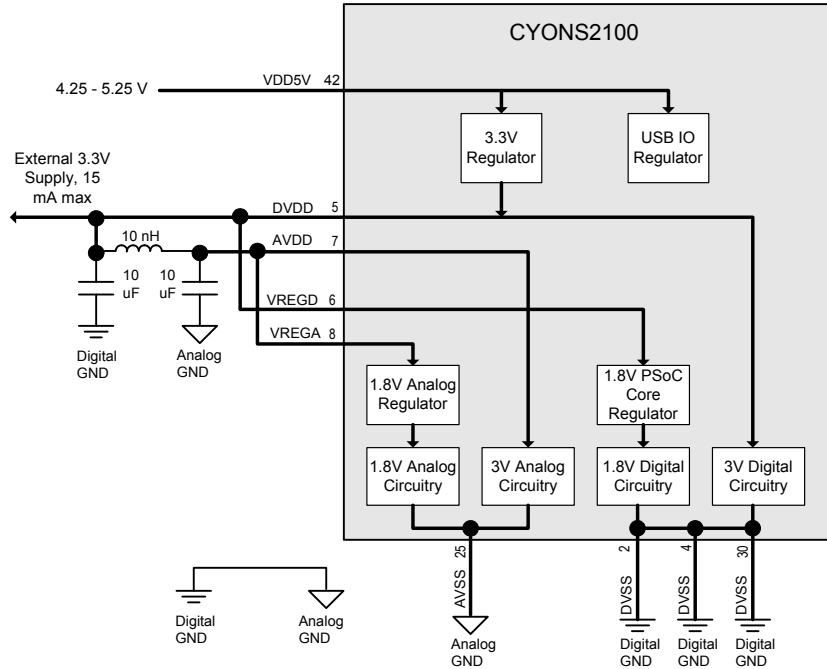

Overview

The CYONS2100 incorporates a powerful and flexible powering system. It can be powered from one of two sources: a 5V supply (typically from the USB VBUS line) or an external 3.3V supply. Additionally, the CYONS2100's internal regulators can supply current to external devices. This section describes the capabilities and usage of the power system. Refer to [Figure 6](#) for a block diagram of the CYONS2100's power system.

Understanding DVDD

DVDD is a unique pin because it can serve as either an input or an output. When the device is powered from USB (using the 3.3V Regulator), DVDD acts as an output, providing a 3.3V voltage that can be used to power AVDD, VREGD, VREGA, and external parts. When the device is powered from an external 3.3V supply, DVDD acts as an input only.

AVDD, VREGA, and VREGD

As with DVDD, these signals power the internal circuitry of the device. Unlike DVDD, these are always inputs. They should be connected as shown in the figure.

Using USB Power

For most USB applications, the device is powered from the USB VBUS signal. In this case, the 5V VBUS signal should be connected directly to the CYONS2100's VDD5V pin.

Using External Power

The CYONS2100 can also be powered from an external source. In this case, the external 3.3V source should connect to DVDD, and VDD5V should be left unconnected.

Filtering and Grounding

For all designs, it is important to provide proper grounding and proper isolation between the analog and digital power supplies. The analog and digital grounds should be isolated, except for a single connection point that is placed very close to the device. On the supply side, an L-C filter should be placed between AVDD and DVDD, as shown in the figure.

Wired Mouse Application Example

The drawing below shows an implementation of a wired mouse. For complete details, refer to the CY4631 Reference Design Kit.

Figure 7. Wired Mouse

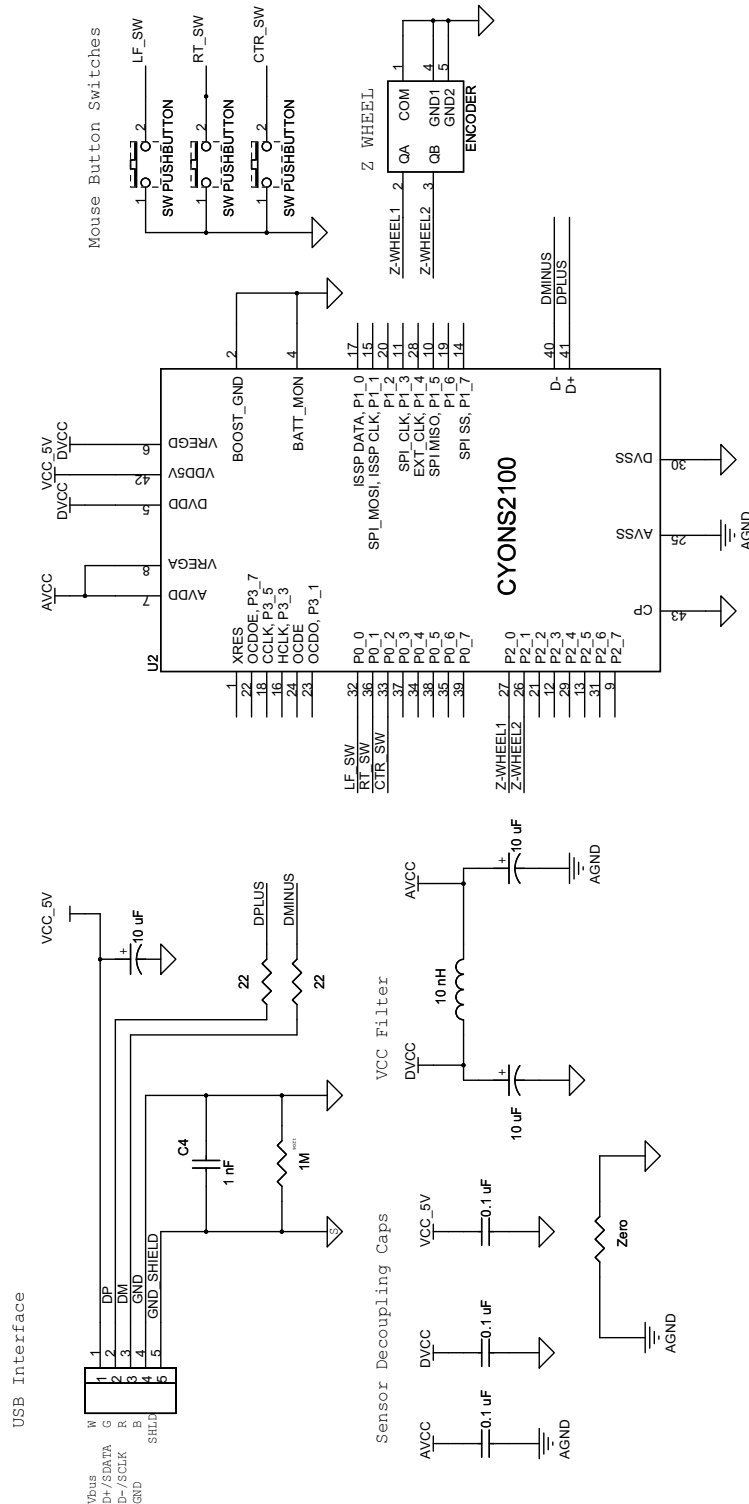

Electrical Specifications

This section presents the DC and AC electrical specifications of the CYONS2100 device. For the most up-to-date electrical specifications, confirm that you have the most recent data sheet by going to <http://www.cypress.com>.

Absolute Maximum Ratings

Parameter	Min	Typ	Max	Unit	Conditions
Storage Temperature	-40		85	°C	Case temperature
Operating Temperature	-15		55	°C	Case temperature
Lead Solder Temperature			260	°C	10 seconds
Supply Voltage, DVDD, AVDD, VREGA, and VREGD relative to DVSS)				V	
Supply Voltage, VDD5V relative to DVSS				V	
ESD (Electric Static Discharge)			2	kV	All pins, HBM MIL 883 method 3015
IO Voltage relative to DVSS	-0.5		DVDD + 0.5	V	GPIO ports 0, 2, and 3
IO Voltage relative to DVSS			5.5	V	GPIO port 1
Latchup Current			100	mA	
Maximum current into any GPIO pin	-25		+50	mA	

Operating Conditions

Parameter	Min	Typ	Max	Unit	Conditions
Operating Temperature	5		45	°C	
Power Supply Voltage				V	
VDD5V	4.35		5.25		
DVDD, AVDD, VREGD	2.7		3.6		
VREGA	1.71		3.6		
Power Supply Rise Time	100			µs	
Supply Noise—AVDD (sinusoidal)			25	mV p-p	10 kHz–50 MHz
Supply Noise—VDD, DVDD (sinusoidal)			100	mV p-p	10 kHz–50 MHz
Distance from PCB to Tracking Surface	5.80	6	6.20	mm	See Figure 17 on page 26
PCB Thickness	1.54		1.79	mm	See Figure 17 on page 26

Power Consumption

Introduction

As described earlier, the CYONS2100 has a highly advanced power system, which can be used to develop very low power applications. This section describes and specifies the power consumption performance of the device.

Enabling Low-Power Modes

In some cases, designers may want to develop “always-on” applications, with no power-saving modes and consequently no wakeup latency in performance. In other applications, conserving power is crucial, and power-saving modes are a firm requirement. The CYONS2100 enables low-power modes to be enabled or disabled in firmware, either through register writes or through the application programming interface in Cypress’s PSoC Designer development software. The remainder of this section applies to applications requiring power-saving modes.

Operating Modes

From a power consumption standpoint, there are three operating modes to consider:

- **Tracking mode:** In this mode, the device is actively tracking on a surface. It is the highest power mode of the device. The current consumption is slightly dependent on speed and surface. The current, however, is independent of resolution.
- **Inactive mode:** In this mode, the device is in its lowest power state. In inactive mode, the device cannot sense motion, but a timer is running. The timer can generate an interrupt that can wake the rest of the device and start tracking motion.
- **Sleep modes:** In sleep modes, the device self-transitions between tracking mode and inactive mode. The typical use of sleep modes is when the device is at rest, but might still be moved. In Sleep modes, the CYONS2100 stays in inactive mode for a fixed time, then wakes up and checks for motion. If motion is detected, the device fully wakes up and begins tracking. If no motion is detected, the device can go back to Sleep mode.

Power Management Through Sleep Mode Control

Power management for the CYONS2100 consists of setting the parameters that define the sleep modes. The device is equipped

with four sets of sleep mode settings, enabling four levels of sleep. By controlling the parameters of these four sleep modes, the designer can tailor the solution to make appropriate tradeoffs between power consumption and wakeup latency.

The transition between sleep modes is under the control of the CYONS2100’s DSP; no firmware needs to be written to manage the transition between modes.

Each of the four available sleep modes is defined by three parameters. These parameters are defined as registers that can be controlled by firmware, either through direct register writes or by using the NAV User Module in PSoC Designer.

- **Sleep time:** This is the amount of time that the device is in its low-power inactive state.
- **Motion threshold:** This is the amount of motion that is required to bring the device out of sleep.
- **Sleep mode time:** This is the amount of time that the device stays in a particular sleep mode before transitioning to the next lowest sleep mode. Longer sleep times save power but have higher wakeup latency.

Figure 8 shows the flowchart for a particular sleep mode, showing how the three parameters affect behavior.

Calculating Power for Sleep Mode

The power consumption in sleep mode can be found by using a duty cycle calculation. The sleep mode current is determined by the tracking mode current, the inactive current, the time required to check for motion (typically 2.3 ms), and the time between check-for-motion events. The expected current consumption is given by the formula

$$I_{SLEEP} = \frac{I_{TRACK} \times 2.3 + I_{INACT} \times T_{SLEEP}}{2.3 + T_{SLEEP}}$$

where I_{SLEEP} is the sleep current, I_{TRACK} is the tracking current, I_{INACT} is the inactive current, and T_{SLEEP} is the time (in ms) in the low power state. As an example, if the tracking current is 7.0 mA, the inactive current is 30 μ A and the sleep time is 100 ms, then the expected sleep current is 0.19 mA.

Figure 8. Sleep Mode Flowchart

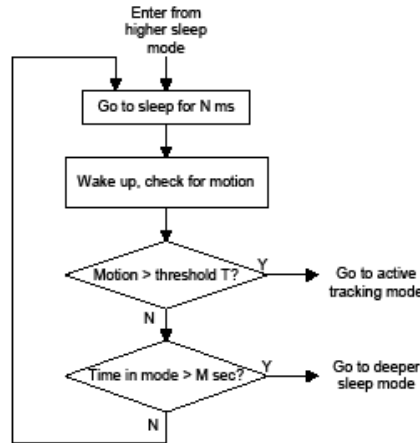

Power Consumption Specifications

Table 5 provides the current consumption values for the CYONS2100.

In general, there are two components to total current consumption. The first is the total current drawn by the DVDD, AVDD, VREGA, and VREGD pins. The second is the current drawn by the internal regulator that drives these pins.

For externally powered designs, no internal regulator is active, and no additional current is present.

For designs powered by the VDD5V pin, the 5V-to-3V regulator is active, and the current consumption of this block, specified in

Table 5, must be included in the total. Also, the USB block is run directly from this regulator, so USB-based designs should include the additional current.

Sleep current is achieved by activating power-saving modes through firmware. Doing so enables the sleep mode progressions described earlier, and also causes the laser and detector circuitry to turn on and off as needed to minimize power. For the CYONS2100, low-power operation is only needed to support USB Suspend. Reference code for this is available in the CY4631 Wired Mouse Reference Design Kit. If sleep modes are not activated, the device current stays at tracking current levels, even when the device is not sensing motion.

Table 4. Power Consumption Specifications

Symbol	Description	Conditions	Min	Typ	Max	Units
I _{TRACK}	Tracking current into DVDD, AVDD, VREGD, VREGA	3.6V, 45C, 10 inch/second, 24 MHz IMO, 6 MHz CPU clock, power-saving modes enabled, white surface, USB active		9		mA
I _{TRACK2}	High performance tracking current into DVDD, AVDD, VREGD, VREGA	3.6V, 45C, 10 inch/second, 24 MHz IMO, 24 MHz CPU clock, power-saving modes disabled, white surface, USB active		17		mA
I _{INACT}	Inactive current into DVDD, AVDD, VREGD, VREGA	3.6V, 45C, 24 MHz IMO, 6 MHz CPU clock, power-saving modes enabled, white surface		30	s	µA
I _{SLEEP}	Sleep current into DVDD, AVDD, VREGD, VREGA	3.6V, 45C, 24 MHz IMO, 6 MHz CPU clock, power-saving modes enabled, white surface	See previous section			
I _{SB}	Shutdown current, all blocks off into DVDD, AVDD, VREGD, VREGA	3.6V, 25C		12		µA
I _{REG5V}	5V-to-3V regulator current consumption	VDD5V = 5.25V		250	300	µA

DC General Purpose IO Specifications

The following tables list guaranteed maximum and minimum specifications for the voltage range of 2.7V to 3.6V at the DVDD pin, and over the temperature range $5^{\circ}\text{C} \leq T_A \leq 45^{\circ}\text{C}$. Typical parameters apply to 3.3V at 25°C and are for design guidance only.

Table 5. 2.7V to 3.6V DC GPIO Specifications

Symbol	Description	Conditions	Min	Typ	Max	Units
R _{PU}	Pull up Resistor		4	5.6	8	kΩ
V _{OH1}	High Output Voltage Port 2 or 3 Pins	IOH ≤ 10 μA, maximum of 10 mA source current in all IOs.	DVDD - 0.2	–	–	V
V _{OH2}	High Output Voltage Port 2 or 3 Pins	IOH = 1 mA, maximum of 20 mA source current in all IOs.	DVDD - 0.9	–	–	V
V _{OH3}	High Output Voltage Port 0 or 1 Pins with LDO Regulator Disabled for Port 1	IOH < 10 μA, maximum of 10 mA source current in all IOs.	DVDD - 0.2	–	–	V
V _{OH4}	High Output Voltage Port 0 or 1 Pins with LDO Regulator Disabled for Port 1	IOH = 5 mA, maximum of 20 mA source current in all IOs.	DVDD - 0.9	–	–	V
V _{OH5}	High Output Voltage Port 1 Pins with LDO Regulator Enabled for 3V Out	IOH < 10 μA, DVDD > 3.1V, maximum of 4 IOs all sourcing 5 mA.	2.85	3.00	3.30	V
V _{OH6}	High Output Voltage Port 1 Pins with LDO Regulator Enabled for 3V Out	IOH = 5 mA, DVDD > 3.1V, maximum of 20 mA source current in all IOs.	2.20	–	–	V
V _{OH7}	High Output Voltage Port 1 Pins with LDO Enabled for 2.5V Out	IOH < 10 μA, DVDD > 2.7V, maximum of 20 mA source current in all IOs.	2.35	2.50	2.75	V
V _{OH8}	High Output Voltage Port 1 Pins with LDO Enabled for 2.5V Out	IOH = 2 mA, DVDD > 2.7V, maximum of 20 mA source current in all IOs.	1.90	–	–	V
V _{OH9}	High Output Voltage Port 1 Pins with LDO Enabled for 1.8V Out	IOH < 10 μA, DVDD > 2.7V, maximum of 20 mA source current in all IOs.	1.60	1.80	2.10	V
V _{OH10}	High Output Voltage Port 1 Pins with LDO Enabled for 1.8V Out	IOH = 1 mA, DVDD > 2.7V, maximum of 20 mA source current in all IOs.	1.20	–	–	V
V _{OL}	Low Output Voltage	IOL = 25 mA, DVDD > 3.3V, maximum of 60 mA sink current on even port pins (for example, P0[2] and P1[4]) and 60 mA sink current on odd port pins (for example, P0[3] and P1[5]).	–	–	0.75	V
V _{IL}	Input Low Voltage		–	–	0.80	V
V _{IH}	Input High Voltage		2.00	–	–	V
V _H	Input Hysteresis Voltage		–	80	–	mV
I _{IL}	Input Leakage (Absolute Value)	Gross tested to 1 μA.	–	0.5	1	μA
C _{PIN}	Pin Capacitance	Temp = 25°C.	0.5	1.7	8	pF

DC Analog Mux Bus Specifications

The following table lists guaranteed maximum and minimum specifications for the entire voltage and temperature ranges.

Table 6. DC Analog Mux Bus Specifications

Parameter	Description	Conditions	Min	Typ	Max	Unit
R _{SW}	Switch Resistance to Common Analog Bus	Pin voltage < 1.8V	–	–	800	Ω
R _{VDD}	Resistance of Initialization Switch to DVSS	Pin voltage < 1.8V	–	–	800	Ω

DC Low Power Comparator Specifications

The following table lists guaranteed maximum and minimum specifications for the entire voltage and temperature ranges.

Table 7. DC Low Power Comparator Specifications

Parameter	Description	Conditions	Min	Typ	Max	Unit
V _{LPC}	Low Power Comparator (LPC) common mode	Maximum voltage limited to DVDD.	0.0	–	1.8	V
I _{LPC}	LPC supply current		–	10	40	μA
V _{OSLPC}	LPC voltage offset		–	2.5	30	mV

DC POR and LVD Specifications

The following table lists guaranteed maximum and minimum specifications for the entire voltage and temperature ranges.

Table 8. DC POR and LVD Specifications

Parameter	Description	Conditions	Min	Typ	Max	Unit
V _{PPOR0}	DVDD Value for PPOR Trip	DVDD must be greater than or equal to 1.71V during startup, reset from the XRES pin, or reset from watchdog.	1.61	1.66	1.71	V
V _{PPOR1}	PORLEV[1:0] = 00b, HPOR = 0					
V _{PPOR2}	PORLEV[1:0] = 00b, HPOR = 1					
V _{PPOR3}	PORLEV[1:0] = 01b, HPOR = 1					
V _{PPOR3}	PORLEV[1:0] = 10b, HPOR = 1		–	2.60	2.65	V
				2.82	2.95	V
V _{LVD0}	Vdd Value for LVD Trip		2.40 ^[2]	2.45	2.51	V
V _{LVD1}	VM[2:0] = 000b		2.64 ^[3]	2.71	2.78	V
V _{LVD2}	VM[2:0] = 001b		2.85 ^[4]	2.92	2.99	V
V _{LVD3}	VM[2:0] = 010b		2.95	3.02	3.09	V
V _{LVD4}	VM[2:0] = 011b		3.06	3.13	3.20	V
V _{LVD5}	VM[2:0] = 100b		1.84	1.90	2.32	V
V _{LVD6}	VM[2:0] = 101b		1.75 ^[5]	1.80	1.84	V

Notes

2. Always greater than 50 mV above V_{PPOR1} voltage for falling supply.
3. Always greater than 50 mV above V_{PPOR2} voltage for falling supply.
4. Always greater than 50 mV above V_{PPOR3} voltage for falling supply.
5. Always greater than 50 mV above V_{PPOR0} voltage for falling supply.

DC Programming Specifications

The following table lists guaranteed maximum and minimum specifications for the entire voltage and temperature ranges.

The CYONS2100 must be properly powered for Flash programming, with DVDD, AVDD, VREGD and VREGA all held within the specified range. A suitable option for in-circuit programming USB designs is to apply 5V to the VDD5V pin, and use the internal regulator to drive DVDD, AVDD, VREGD, and VREGA. This enables direct connection to Cypress's CY3210-Minipro. For in-circuit programming of externally-powered designs, the designer must include provisions for supplying DVDD, AVDD, VREGD, and VREGA externally.

Table 9. DC Programming Specifications

Parameter	Description	Conditions	Min	Typ	Max	Unit
V _{IW}	Supply Voltage for Flash Write Operations	V _{IW} applied to DVDD, AVDD, VREGD and VREGA	2.7	–	3.6	V
I _{DDP}	Supply Current During Programming or Verify		–	5	25	mA
V _{ILP}	Input Low Voltage During Programming or Verify	See “DC General Purpose IO Specifications” on page 15.	–	–	V _{IL}	V
V _{IHP}	Input High Voltage During Programming or Verify	See “DC General Purpose IO Specifications” on page 15.	V _{IH}	–	–	V
I _{ILP}	Input Current when Applying V _{ilp} to P1[0] or P1[1] During Programming or Verify	Driving internal pull down resistor.	–	–	0.2	mA
I _{IHP}	Input Current when Applying V _{ihp} to P1[0] or P1[1] During Programming or Verify	Driving internal pull down resistor.	–	–	1.5	mA
V _{OLP}	Output Low Voltage During Programming or Verify		–	–	V _{ss} + 0.75	V
V _{OHP}	Output High Voltage During Programming or Verify	“DC General Purpose IO Specifications” on page 15. For DVDD > 3V use the value with I _{OH} = 5 mA.	V _{OH}	–	V _{dd}	V
Flash _{ENPB}	Flash Write Endurance	Erase/write cycles by block.	50,000	–	–	Cycles
Flash _{DR}	Flash Data Retention	Following maximum flash write cycles.	8	20	–	Years

DC Characteristics - USB Interface

Table 10. DC USB Characteristics

Symbol	Description	Conditions	Min	Typ	Max	Units
R _{usb} i	USB D+ pull up resistance	With idle bus	0.900	TBD	1.575	kΩ
R _{usb} a	USB D+ pull up resistance	While receiving traffic	1.425	TBD	3.090	kΩ
V _{ohusb}	Static Output High		2.8	TBD	3.6	V
V _{olusb}	Static Output Low			TBD	0.3	V
V _{di}	Differential Input Sensitivity		0.2	TBD		V
V _{cm}	Differential Input Common Mode Range		TBD	TBD	TBD	V
V _{se}	Single Ended Receiver Threshold		0.8	TBD	2.0	V
C _{in}	Transceiver Capacitance			TBD	50	pF
I _{io}	Hi-Z State Data Line Leakage	On D+ or D- line	TBD	TBD	TBD	uA
R _{ps2}	PS/2 Pull-up resistance		3	TBD	7	kΩ
R _{ext}	External USB Series Resistor	In series with each USB pin	21.78	22	22.22	Ω

AC Chip Level Specifications

The following table lists guaranteed maximum and minimum specifications for the entire voltage and temperature ranges.

Table 11. AC Chip Level Specifications

Parameter	Description	Min	Typ	Max	Unit
F _{MAX}	Maximum Operating Frequency ^[6]	24			MHz
F _{CPU}	Maximum Processing Frequency ^[7]	13			MHz
F _{32K1}	Internal Low Speed Oscillator Frequency	19	32	50	kHz
F _{IMO24}	Internal Main Oscillator Stability for 24 MHz ± 5% ^[8]	22.8	24	25.2	MHz
F _{IMO12}	Internal Main Oscillator Stability for 12 MHz ^[8]	11.4	12	12.6	MHz
F _{IMO6}	Internal Main Oscillator Stability for 6 MHz ^[8]	5.7	6.0	6.3	MHz
DC _{IMO}	Duty Cycle of IMO	40	50	60	%
T _{RAMP}	Supply Ramp Time	0	–	–	μs
TXRST	External Reset Pulse Width at Power Up	1			ms
TXRST2	External Reset Pulse Width after Power Up	10			μs
TMOT	Motion delay from reset to valid tracking data			30	ms

AC General Purpose IO Specifications

The following table lists guaranteed maximum and minimum specifications for the entire voltage and temperature ranges.

Table 12. AC GPIO Specs

Parameter	Description	Conditions	Min	Typ	Max	Units
F _{GPIO}	GPIO Operating Freq	Strong Mode, Port 1	0	–	12	MHz
T _{RISE_01}	Rise time, ports 0 -1	Strong mode, C _{LOAD} = 50pF, DVDD = 3.0 - 3.6	10		50	ns
T _{RISE_01_L}	Rise time, ports 0 -1, low supply	Strong mode, C _{LOAD} = 50pF, DVDD = 2.7 - 3.0			70	ns
T _{RISE_LDO_3}	Rise time, port 1, 3V LDO enabled	Strong mode, C _{LOAD} = 50pF, DVDD > 3.1V			50	ns
T _{RISE_LDO_2.5}	Rise time, port 1, 2.5 LDO enabled	Strong mode, C _{LOAD} = 50pF, DVDD > 2.7V	10		70	ns
T _{RISE_LDO_1.8}	Rise time, port 1, 1.8 LDO enabled	Strong mode, C _{LOAD} = 50pF, DVDD > 2.7V			100	ns
T _{RISE_23}	Rise time, ports 2 - 3	Strong mode, C _{LOAD} = 50pF, DVDD = 2.7 - 3.6	15		80	ns
T _{FALL}	Fall time, all ports	Strong mode, C _{LOAD} = 50pF, DVDD = 3.0 - 3.6	10		50	ns
T _{FALL_L}	Fall time, all ports, low supply	Strong mode, C _{LOAD} = 50pF, DVDD = 2.7 - 3.0	10		70	ns
T _{FALL_LDO_3}	Fall time, port 1, 3V LDO enabled	Strong mode, C _{LOAD} = 50pF, DVDD > 3.1V			50	ns
T _{FALL_LDO_2.5}	Fall time, port 1, 2.5 LDO enabled	Strong mode, C _{LOAD} = 50pF, DVDD > 2.7V			70	ns
T _{FALL_LDO_1.8}	Fall time, port 1, 1.8 LDO enabled	Strong mode, C _{LOAD} = 50pF, DVDD > 2.7V			80	ns

Notes

- 6. V_{dd} = 3.0V and T_j = 85°C, digital clocking functions.
- 7. V_{dd} = 3.0V and T_j = 85°C, CPU speed.
- 8. Trimmed for 3.3V operation using factory trim values.

AC External Clock Specifications

The following table lists guaranteed maximum and minimum specifications for the entire voltage and temperature ranges.

Table 13. AC External Clock Specifications

Parameter	Description	Min	Typ	Max	Unit
F _{OSCEXT}	Frequency	0.750	–	25.2	MHz
–	High Period	20.6	–	5300	ns
–	Low Period	20.6	–	–	ns
–	Power Up IMO to Switch	150	–	–	µs

AC Analog Mux Bus Specifications

The following table lists guaranteed maximum and minimum specifications for the entire voltage and temperature ranges.

Table 14. AC Analog Mux Bus Specifications

Parameter	Description	Conditions	Min	Typ	Max	Unit
F _{SW}	Switch Rate	Pin voltage < 1.8V	–	–	6.3	MHz

AC Programming Specifications

The following table lists guaranteed maximum and minimum specifications for the entire voltage and temperature ranges.

Table 15. AC Programming Specifications

Symbol	Description	Conditions	Min	Typ	Max	Units
T _{RSCLK}	Rise Time of SCLK		1	–	20	ns
T _{FSCLK}	Fall Time of SCLK		1	–	20	ns
T _{SSCLK}	Data Set up Time to Falling Edge of SCLK		40	–	–	ns
T _{HSCLK}	Data Hold Time from Falling Edge of SCLK		40	–	–	ns
F _{SCLK}	Frequency of SCLK		0	–	8	MHz
T _{ERASEB}	Flash Erase Time (Block)		–	–	18	ms
T _{WRITE}	Flash Block Write Time		–	–	25	ms
T _{DSCLK2}	Data Out Delay from Falling Edge of SCLK	3.0 ≤ DVDD ≤ 3.6	–	–	85	ns

AC SPI Specifications

The following table lists guaranteed maximum and minimum specifications for the entire voltage and temperature ranges.

Table 16. AC SPI Master Specifications

Parameter	Description	Min	Typ	Max	Unit
f _{SCLK}	SCK Frequency ^[9]	–	–	F _{IMO} /2	MHz
t _{SETUP}	MISO to SCK Setup Time			150	ns
t _{HOLD}	SCLK to MISO Hold Time	-100			ns
t _{OUT_SU}	MOSI to SCK Setup Time			200	ns
t _{OUT_H}	SCK to MOSI Hold Time	-100			ns

Table 17. AC SPI Slave Specifications

Parameter	Description	Min	Typ	Max	Unit
f _{SCLK}	SCK Frequency ^[9]			12	MHz
t _{LOW}	Minimum SCK Low Width			50	ns
t _{HIGH}	Minimum SCK High Width			50	ns
t _{SETUP}	MOSI to SCK Setup Time			25	ns
t _{HOLD}	SCK to MOSI Hold Time			25	ns
t _{OUT_H}	SCK to MISO Hold Time	35			ns
t _{SS_MISO}	SPI_SS to MISO Valid			100	ns
t _{SCLK_MISO}	SCK to MISO Valid			140	ns
t _{SS_HIGH}	Minimum SPI_SS High Width			35	ns
t _{SS_CLK}	Time from SPI_SS Low to First SCK			20	ns
t _{CLK_SS}	Time from Last SCK to SPI_SS High			25	ns

Note

9. Clock frequency is half of clock input to SPI block.

Figure 9. SPI Master Timing Diagram, Modes 0 and 2

SPI Master, modes 0 & 2

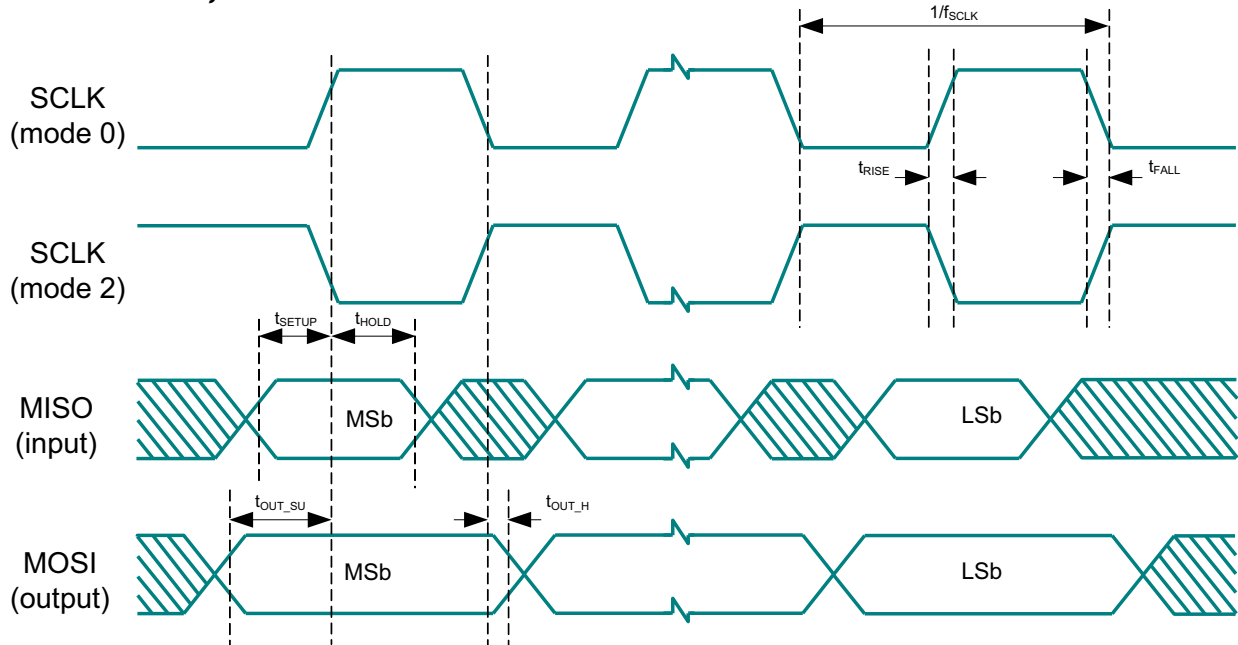

Figure 10. SPI Master Timing Diagram, Modes 1 and 3

SPI Master, modes 1 & 3

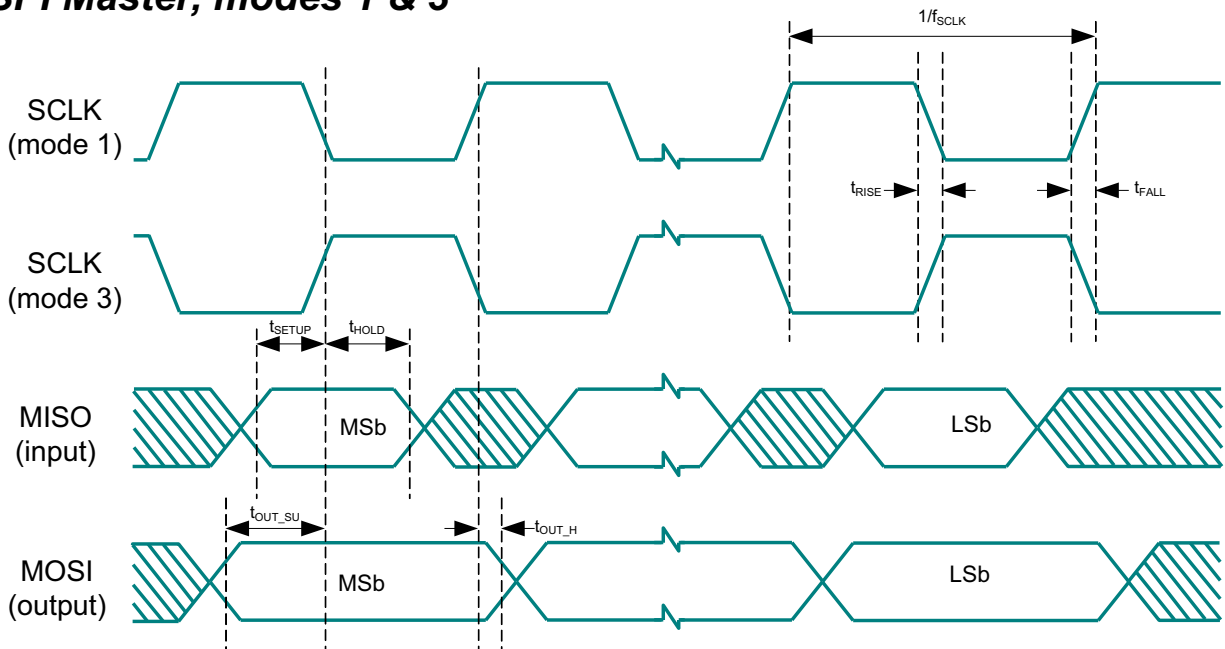

Figure 11. SPI Slave Timing Diagram, Modes 0 and 2

SPI Slave, modes 0 & 2

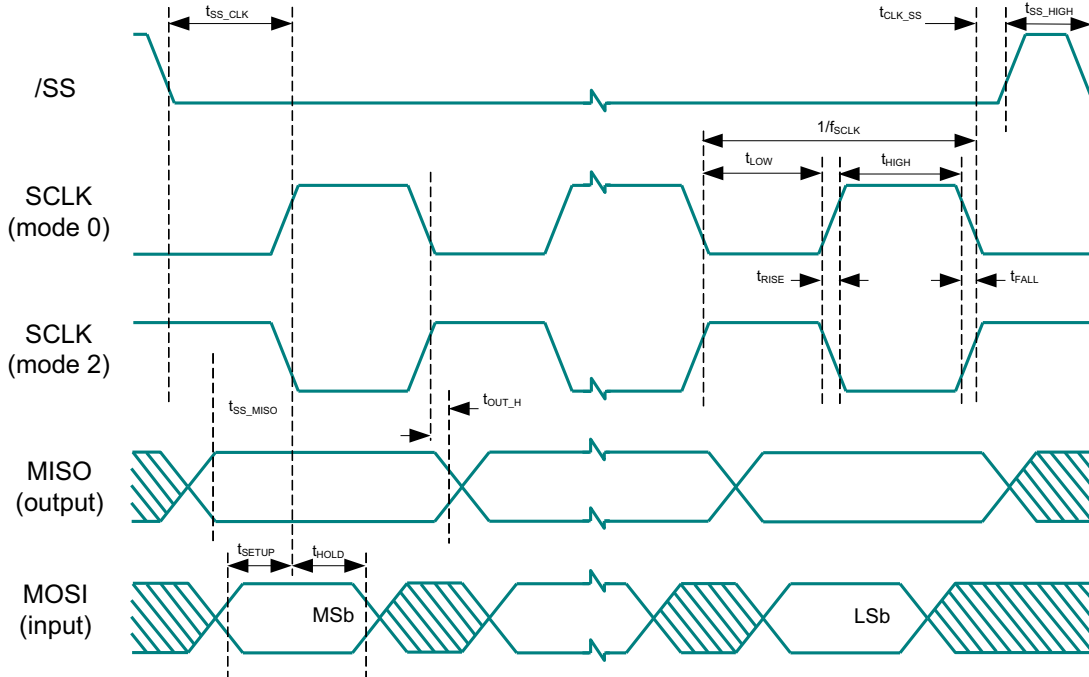
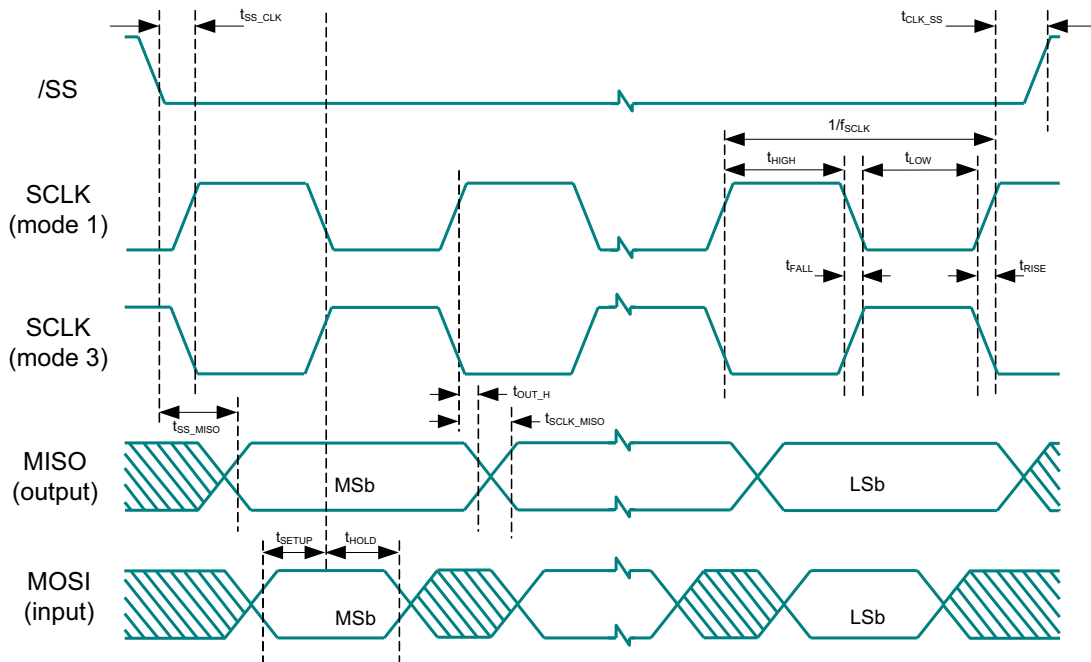

Figure 12. SPI Slave Timing Diagram, Modes 1 and 3

SPI Slave, modes 1 & 3



AC Comparator Specifications

The following table lists guaranteed maximum and minimum specifications for the entire voltage and temperature ranges.

Table 18. AC Low Power Comparator Specifications

Symbol	Description	Conditions	Min	Typ	Max	Units
T _{LPC}	Comparator Response Time, 50 mV Overdrive	50 mV overdrive does not include offset voltage.			100	ns

AC I²C Specifications

The following table lists guaranteed maximum and minimum specifications for the entire voltage and temperature ranges.

Table 19. AC Characteristics of the I²C SDA and SCL Pins

Symbol	Description	Conditions	Standard Mode		Fast Mode		Units
			Min	Max	Min	Max	
F _{SCL I2C}	SCL Clock Frequency		0	100	0	400	kHz
T _{HDSTA I2C}	Hold Time (repeated) START Condition. After this period, the first clock pulse is generated.		4.0	–	0.6	–	μs
T _{LOW I2C}	LOW Period of the SCL Clock		4.7	–	1.3	–	μs
T _{HIGH I2C}	HIGH Period of the SCL Clock		4.0	–	0.6	–	μs
T _{SUSTA I2C}	Setup Time for a Repeated START Condition		4.7	–	0.6	–	μs
T _{HDDAT I2C}	Data Hold Time		0	–	0	–	μs
T _{SUDAT I2C}	Data Setup Time		250	–	100 ^[10]	–	ns
T _{SUSTO I2C}	Setup Time for STOP Condition		4.0	–	0.6	–	μs
T _{BUFI2C}	Bus Free Time Between a STOP and START Condition		4.7	–	1.3	–	μs
T _{SPI2C}	Pulse Width of spikes are suppressed by the input filter.		–	–	0	50	ns

Figure 13. Timing for Fast and Standard Mode on the I²C Bus

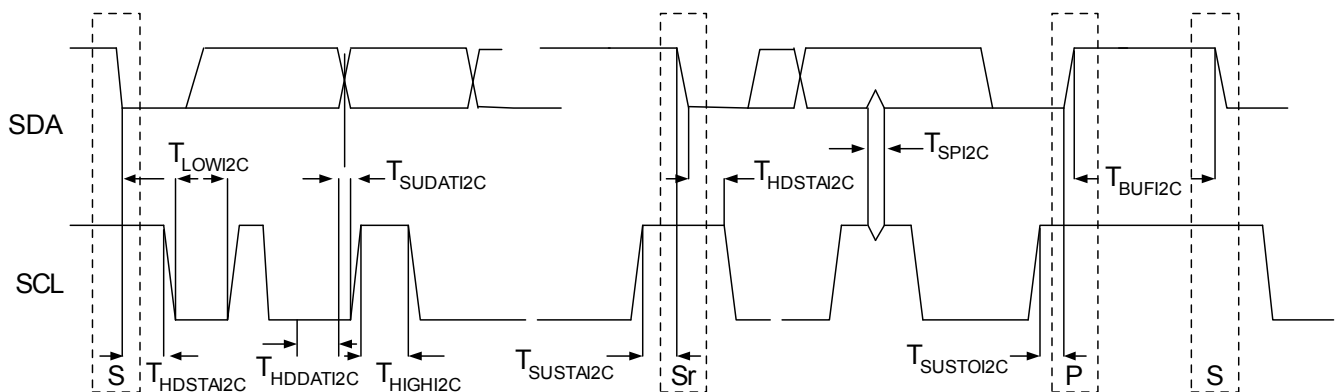

Note
10. Output clock frequency is half of input clock rate.

AC USB Specifications

Table 20. AC Characteristics – USB Data Timing Specifications

Symbol	Description	Conditions	Min	Typ	Max	Units
Tdrate	Full speed data rate	Average bit rate	12-0.25%	12	12 + 0.25	MHz
Tdjr1	Receiver data jitter tolerance	To next transition	-8	TBD	8	ns
Tdjr2	Receiver data jitter tolerance	To pair transition	-5	TBD	5	ns
Tudj1	Driver differential jitter	To next transition	-3.5	TBD	3.5	ns
Tudj2	Driver differential jitter	To pair transition	-4.0	TBD	4.0	ns
Tfdeop	Source jitter for differential transition	To SE0 transition	-2	TBD	5	ns
Tfeopt	Source SE0 interval of EOP		160	TBD	175	ns
Tfeopr	Receiver SE0 interval of EOP		82	TBD		ns
Tfst	Width of SE0 interval during differential transition			TBD	14	ns

Table 21. AC Characteristics – USB Driver

Symbol	Description	Conditions	Min	Typ	Max	Units
Tr	Transition rise time	50 pF	4	TBD	20	ns
Tf	Transition fall time	50 pF	4	TBD	20	ns
TR	Rise/fall time matching	0.8V - 2.5V	90.00	TBD	111.11	%
Vcrs	Output signal crossover voltage		1.3	TBD	2.0	V

PCB Land Pads and Mechanical Dimensions

Figure 14. Land Pad Architecture and Spacing according to JEDEC MO-220 (52 Lead)

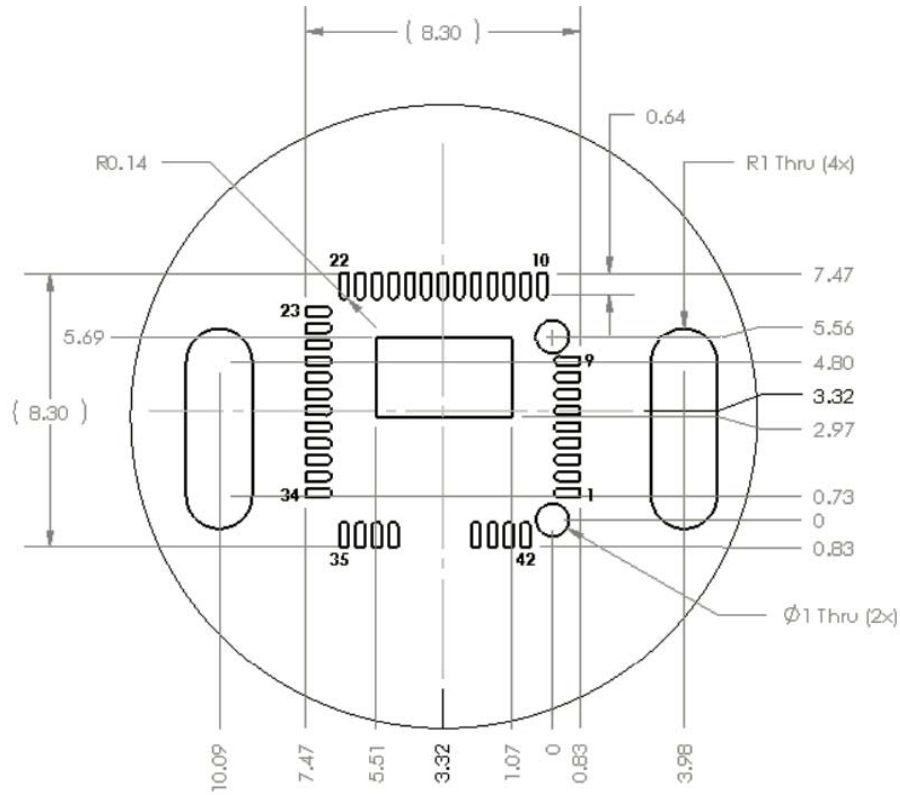
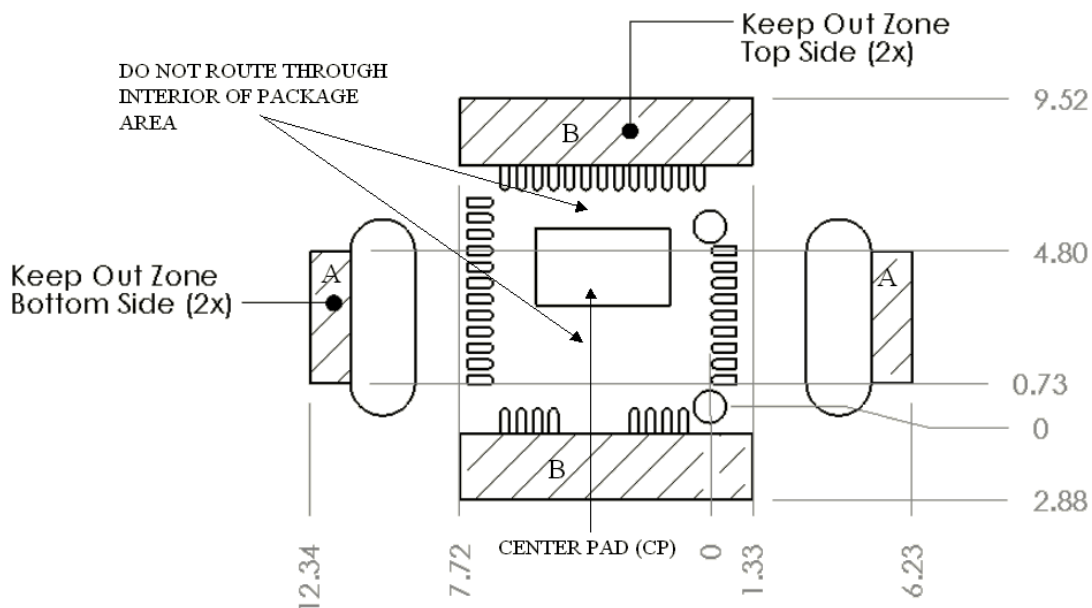

Figure 15. PCB Keep Out Zones



Orientation of Axes

Figure 16 describes the relationship between the package and the x and y axes for reported motion data. Note that for a typical mouse application, this sensor orientation requires inversion (multiply by -1) of the y data. Designs using Cypress's PSoC Designer software and the Ovation II user modules have this inversion done automatically. Designs using direct reads of y registers need the inversion done in application firmware.

Figure 16. Sensor Orientation

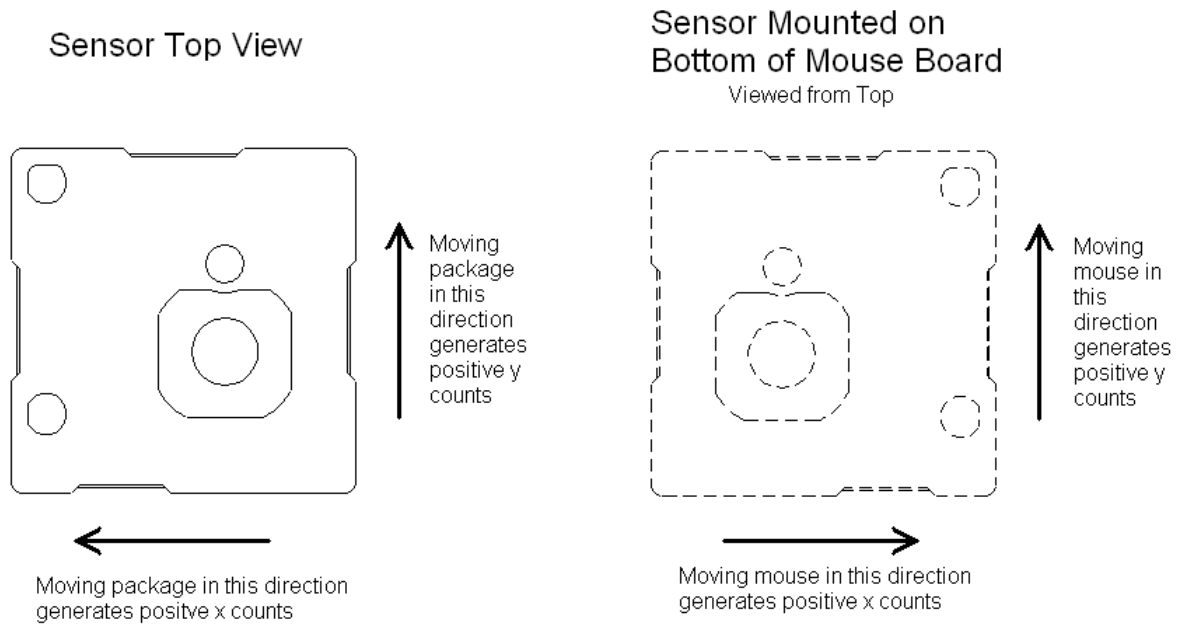

PCB Mounting Height and Thickness

Figure 17 shows the recommended thickness and mounting height of the PCB above the tracking surface.

Figure 17. PCB Height and Thickness

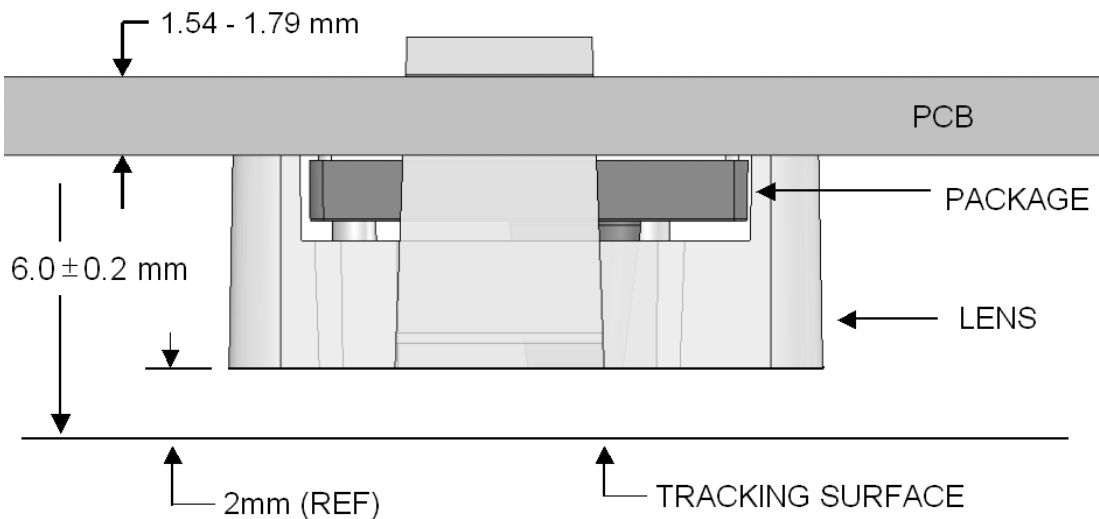

Thermal Impedances

Table 22. Thermal Impedances per Package

Package	Typical θ_{JA} ^[11]
42 PQFN ^[12]	46 °C/W

Solder Reflow Peak Temperature

Following is the minimum solder reflow peak temperature to achieve good solderability.

Table 23. Solder Reflow Peak Temperature

Package	Minimum Peak Temperature ^[13]	Maximum Peak Temperature
42 PQFN	240°C	260°C

Notes

11. $T_J = T_A + \text{Power} \times \theta_{JA}$.

12. To achieve the thermal impedance specified for the QFN package, the center thermal pad must be soldered to the PCB ground plane.

13. Higher temperatures may be required based on the solder melting point. Typical temperatures for solder are $220 \pm 5^\circ\text{C}$ with Sn-Pb or $245 \pm 5^\circ\text{C}$ with Sn-Ag-Cu paste. Refer to the solder manufacturer specifications.

Laser Safety Considerations

The CYONS2100 Laser Navigation SoC and the CYONSLENS2000 lens are designed and tested to enable manufacturers to achieve eye safety certification with minimal effort. This section provides guidelines for complying with the Class 1 emission requirements of IEC/EN 60825-1.

When installed and operated in accordance with all requirements in this data sheet, the kit consisting of the CYONS2100 Laser Navigation SoC and CYONSLENS2000 satisfies CDRH 21 CFR 1040 per Laser Notice 50 and IEC/EN 60825-1 Class 1.

Laser Output Power

The CYONS2100 sensor package contains an integrated VCSEL and drive circuitry. Before shipping, Cypress adjusts the laser output power to eye-safe levels, taking into account specified variations in supply voltage, temperature, lens transmission, and VCSEL polarization, and factors such as VCSEL aging and test equipment accuracy. The output remains within eye-safe limits under reasonably foreseeable single-faults, as required by the IEC standard.

From the perspective of a manufacturer, laser emission remains within the Class 1 limit, as defined in IEC 60825-1, Edition 2, 2007, provided the following requirements are met.

- The supply voltage applied to pins DVDD and AVDD of the SoC must be in the range of 2.7 to 3.6V.
- The operating temperature must be between 5 and 45 °C.
- The laser output power must not be increased by any means, including but not limited to firmware, hardware, or mechanical modifications to the sensor or lens.
- The mechanical housing must be designed such that the CYONSLENS2000 cannot be removed by the user.
- The device firmware must initialize the VCSEL driver as described in the “VCSEL Driver” chapter of the OvationONS II Technical Reference Manual.

It is the responsibility of the manufacturer to ensure these conditions are always met and to demonstrate end-product compliance to the appropriate regulatory standards.

Laser Output Power Test Procedure

To verify the laser output level, follow the steps shown in the “VCSEL Power Calibration and Verification” section of the Technical Reference Manual.

Registration Assistance

The mouse or end-product supplier is responsible for certifying the end-use product with respect to the drive voltage, manuals and labels, and operating temperature specifications. Additionally, for products sold in the US, a CDRH report must be filed for each model produced, and test and inspection of the product’s characteristics as they relate to laser safety and the CDRH requirements must be performed.

When filing a report with the CDRH, the supplier can refer to the product report filed by Cypress for the CYONS2xxx family of products. The Cypress report is based on the previously-noted limits for voltage and temperature, and describes how the sensor design includes consideration of drive circuit failures, laser output variation with temperature, drive circuit variation with temperature and voltage, polarization sensitivity of molded optics, and measurement uncertainties.

Cypress can provide assistance to customers who wish to obtain registration. Supporting documentation, including a verification test procedure to demonstrate end-product compliance with IEC and CDRH requirements is available. An application note, “Meeting Laser Safety Requirements with the CYONS2xxx Family of Laser Navigation SoCs”, is also available. For further information, contact a Cypress representative.

Development Tool Selection

This section presents the development tools available for all current PSoC device families including the CYONS2100.

Software

PSoC Designer

At the core of the PSoC development software suite is PSoC Designer. Used by thousands of PSoC developers, this robust software has been facilitating PSoC designs for half a decade. PSoC Designer is available free of charge at <http://www.cypress.com>.

PSoC Programmer

Flexible enough to be used on the bench in development, yet suitable for factory programming, PSoC Programmer works either as a standalone programming application or it can operate directly from PSoC Designer or PSoC Express™. PSoC Programmer software is compatible with both PSoC ICE-Cube In-Circuit Emulator and PSoC MiniProg. PSoC programmer is available free of charge at <http://www.cypress.com/psocprogrammer>.

HI-TECH C Compiler

Cypress's PSoC Designer 5.0 supports a new HI-TECH Lite C Compiler by default, although it still supports CY3202-C iMAGEcraft C Compiler used by previous versions of PSoC Designer. An optional upgrade from HI-TECH Lite to HI-TECH Pro is available for purchase from Cypress Online Store. At <http://www.cypress.com>, click "Buy Kits" at the left bottom of the web page, click "PSoC (Programmable System-on-Chip)", and click "Development Kits", or search for "HI-TECH".

CY3202-C iMAGEcraft C Compiler

CY3202 is the optional upgrade to PSoC Designer that enables the iMAGEcraft C compiler. You can purchase the optional upgrade from the Cypress Online Store at <http://www.cypress.com>. In the store, click the Online Store shopping cart icon at the bottom of the web page, and click *PSoC (Programmable System-on-Chip)* to view a current list of available items.

Reference Design Kits

Two reference design kits featuring the OvationONS II family of products are available. Each kit provides a complete hardware, firmware, and software solution, ready for production.

- CY4631 Wired Mouse Reference Design Kit
- CY4666 Wireless Mouse Reference Design Kit

Development Kits

You can purchase the development kits from the Cypress Online Store.

CY3215-DK Basic Development Kit

The CY3215-DK kit enables prototyping and development with PSoC Designer. This kit supports in-circuit emulation and the software interface enables users to run, halt, and single step the processor and view the content of specific memory locations. Advance emulation features are also supported through PSoC Designer. The kit includes:

- PSoC Designer Software CD
- ICE-Cube In-Circuit Emulator
- ICE Flex-Pod for CY8C29x66 Family
- Cat-5 Adapter
- Mini-Eval Programming Board
- 110 ~ 240V Power Supply, Euro-Plug Adapter
- iMAGEcraft C Compiler (Registration Required)
- ISSP Cable
- USB 2.0 Cable and Blue Cat-5 Cable
- Two CY8C29466-24PXI 28-PDIP Chip Samples

CY3210-ExpressDK PSoC Express Development Kit

The CY3210-ExpressDK enables advanced prototyping and development with PSoC Express (may be used with ICE-Cube In-Circuit Emulator). It provides access to voltage reference, switches, upgradeable modules and more. The kit includes:

- PSoC Express Software CD
- Express Development Board
- Four Fan Modules
- Two Proto Modules
- MiniProg In-System Serial Programmer
- MiniEval PCB Evaluation Board
- Jumper Wire Kit
- USB 2.0 Cable
- Serial Cable (DB9)
- 110 ~ 240V Power Supply, Euro-Plug Adapter
- Two CY8C24423A-24PXI 28-PDIP Chip Samples
- Two CY8C27443-24PXI 28-PDIP Chip Samples
- Two CY8C29466-24PXI 28-PDIP Chip Samples

Evaluation Tools

You can purchase the evaluation tools from the Cypress Online Store.

CY3210-MiniProg1

The CY3210-MiniProg1 kit enables a user to program PSoC devices using the MiniProg1 programming unit. The MiniProg is a small, compact prototyping programmer that connects to the PC through a provided USB 2.0 cable. The kit includes:

- MiniProg Programming Unit
- MiniEval Socket Programming and Evaluation Board
- 28-pin CY8C29466-24PXI PDIP PSoC Device Sample
- 28-pin CY8C27443-24PXI PDIP PSoC Device Sample
- PSoC Designer Software CD
- Getting Started Guide
- USB 2.0 Cable
- CY3210-PSoCEval1

The CY3210-PSoCEval1 kit features an evaluation board and the MiniProg1 programming unit. The evaluation board includes an LCD module, potentiometer, LEDs, and plenty of bread-boarding space to meet all your evaluation needs. The kit includes:

- Evaluation Board with LCD Module
- MiniProg Programming Unit
- 28-pin CY8C29466-24PXI PDIP PSoC Device Sample (2)
- PSoC Designer Software CD
- Getting Started Guide
- USB 2.0 Cable

CY3214-PSoCEvalUSB

The CY3214-PSoCEvalUSB evaluation kit features a development board for the CY8C24794-24LFXI PSoC device. Special features of the board include both USB and capacitive sensing development and debugging support. This evaluation board also includes an LCD module, potentiometer, LEDs, an enunciator and plenty of bread boarding space to meet all your evaluation needs. The kit includes:

- PSoCEvalUSB Board
- LCD Module
- MiniProg Programming Unit
- Mini USB Cable
- PSoC Designer and Example Projects CD
- Getting Started Guide
- Wire Pack

Device Programmers

You can purchase the device programmers from the Cypress Online Store.

CY3216 Modular Programmer

The CY3216 Modular Programmer kit features a modular programmer and the MiniProg1 programming unit. The modular programmer includes three programming module cards and supports multiple Cypress products. The kit includes:

- Modular Programmer Base
- Three Programming Module Cards
- MiniProg Programming Unit
- PSoC Designer Software CD
- Getting Started Guide
- USB 2.0 Cable

CY3207ISSP In-System Serial Programmer (ISSP)

The CY3207ISSP is a production programmer. It includes protection circuitry and an industrial case that is more robust than the MiniProg in a production-programming environment.

Note CY3207ISSP needs special software and is not compatible with PSoC Programmer.

The kit includes:

- CY3207 Programmer Unit
- PSoC ISSP Software CD
- 110 ~ 240V Power Supply, Euro-Plug Adapter
- USB 2.0 Cable

Third-Party Tools

Several tools have been specially designed by third-party vendors to accompany PSoC devices during development and production. Specific details for each of these tools are found at <http://www.cypress.com>.

Package Diagrams

Figure 18. QFN Package

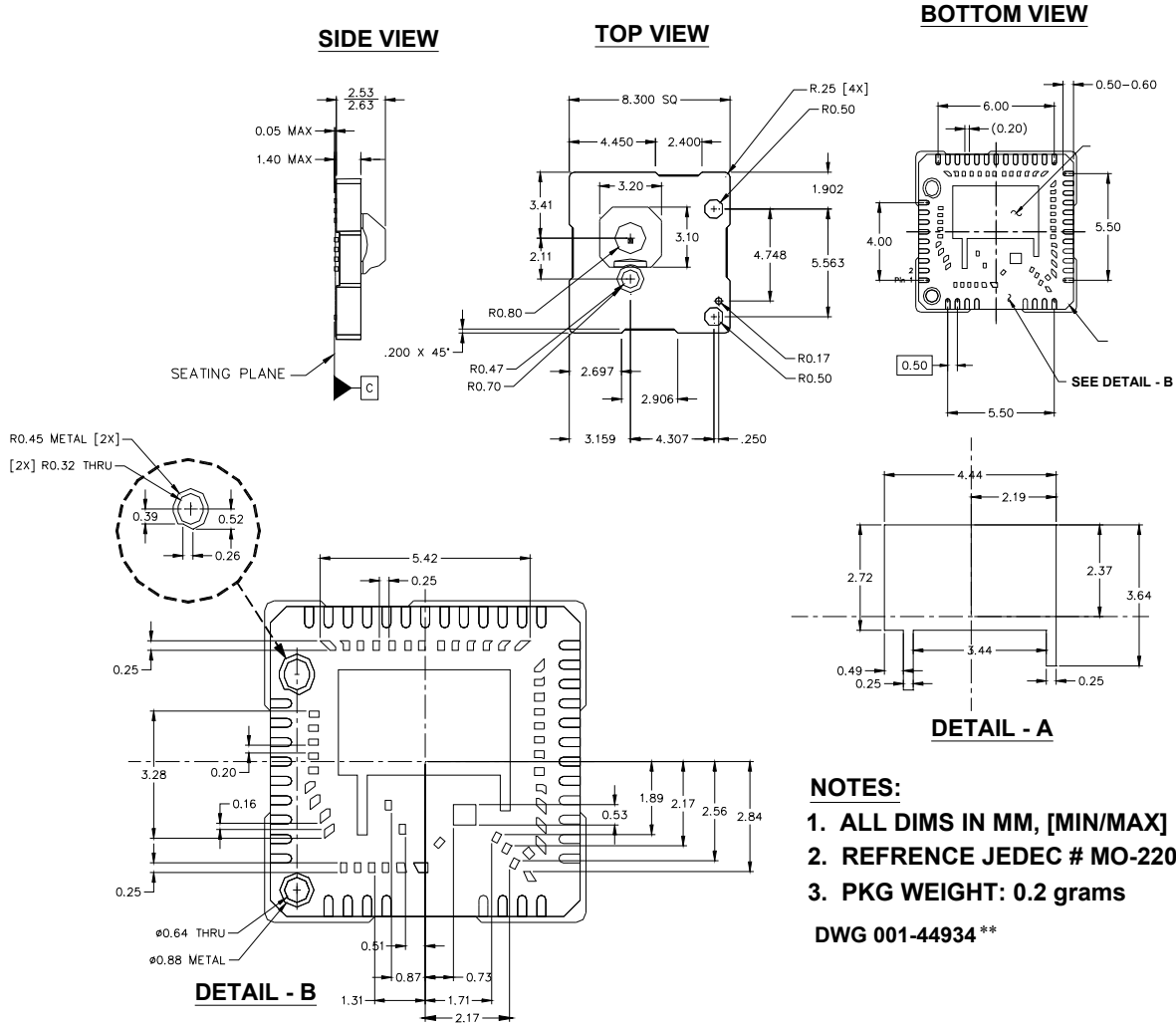

- NOTES:**
1. ALL DIMS IN MM, [MIN/MAX]
 2. REFERENCE JEDEC # MO-220
 3. PKG WEIGHT: 0.2 grams
- DWG 001-44934 **

Figure 19. Lens

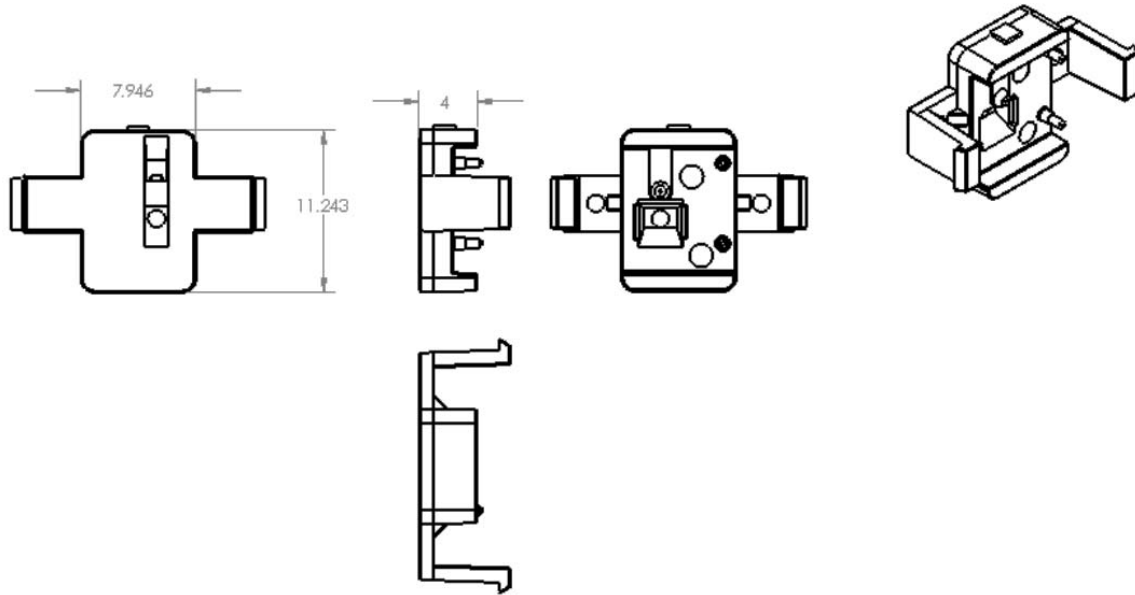

001-44677 **

Ordering Information

The CYONS2100 and CYONSLENS2000 are sold separately. When placing orders, please order both part numbers.

Part Number	Package	Application
CYONS2100-LBXC	42 lead PQFN	High Performance Wired
CYONSLENS2000-C	Lens - 4 mm Height	Molded Optic

Document History Page

Document Title: CYONS2100 OvationONS™ II Wired Gaming Laser Navigation System on Chip				
Document Number: 001-44046				
Revision	ECN	Orig. of Change	Submission Date	Description of Change
**	2261927	FJZ	See ECN	CYONS2100 New Data Sheet.
*A	2580125	FJZ/PYRS	10/07/08	Extensive Updates

Sales, Solutions, and Legal Information

Worldwide Sales and Design Support

Cypress maintains a worldwide network of offices, solution centers, manufacturer’s representatives, and distributors. To find the office closest to you, visit us at cypress.com/sales.

Products

- PSoC psoc.cypress.com
- Clocks & Buffers clocks.cypress.com
- Wireless wireless.cypress.com
- Memories memory.cypress.com
- Image Sensors image.cypress.com

PSoC Solutions

- General psoc.cypress.com/solutions
- Low Power/Low Voltage psoc.cypress.com/low-power
- Precision Analog psoc.cypress.com/precision-analog
- LCD Drive psoc.cypress.com/lcd-drive
- CAN 2.0b psoc.cypress.com/can
- USB psoc.cypress.com/usb

© Cypress Semiconductor Corporation, 2008. The information contained herein is subject to change without notice. Cypress Semiconductor Corporation assumes no responsibility for the use of any circuitry other than circuitry embodied in a Cypress product. Nor does it convey or imply any license under patent or other rights. Cypress products are not warranted nor intended to be used for medical, life support, life saving, critical control or safety applications, unless pursuant to an express written agreement with Cypress. Furthermore, Cypress does not authorize its products for use as critical components in life-support systems where a malfunction or failure may reasonably be expected to result in significant injury to the user. The inclusion of Cypress products in life-support systems application implies that the manufacturer assumes all risk of such use and in doing so indemnifies Cypress against all charges.



Any Source Code (software and/or firmware) is owned by Cypress Semiconductor Corporation (Cypress) and is protected by and subject to worldwide patent protection (United States and foreign), United States copyright laws and international treaty provisions. Cypress hereby grants to licensee a personal, non-exclusive, non-transferable license to copy, use, modify, create derivative works of, and compile the Cypress Source Code and derivative works for the sole purpose of creating custom software and or firmware in support of licensee product to be used only in conjunction with a Cypress integrated circuit as specified in the applicable agreement. Any reproduction, modification, translation, compilation, or representation of this Source Code except as specified above is prohibited without the express written permission of Cypress.

Disclaimer: CYPRESS MAKES NO WARRANTY OF ANY KIND, EXPRESS OR IMPLIED, WITH REGARD TO THIS MATERIAL, INCLUDING, BUT NOT LIMITED TO, THE IMPLIED WARRANTIES OF MERCHANTABILITY AND FITNESS FOR A PARTICULAR PURPOSE. Cypress reserves the right to make changes without further notice to the materials described herein. Cypress does not assume any liability arising out of the application or use of any product or circuit described herein. Cypress does not authorize its products for use as critical components in life-support systems where a malfunction or failure may reasonably be expected to result in significant injury to the user. The inclusion of Cypress’ product in a life-support systems application implies that the manufacturer assumes all risk of such use and in doing so indemnifies Cypress against all charges.

Use may be limited by and subject to the applicable Cypress software license agreement.

Looking for pricing, stock, or lifecycle information?

Click below to explore more details on WIN SOURCE:

-  [View CYONS2100-LBXC on WIN SOURCE](#)
-  [Cypress Semiconductor Corp Information](#)

Optimize Your Supply Chain with WIN SOURCE Solutions

-  Global Sourcing Solution
-  Obsolete Management
-  Cost Control Management
-  Shortage Management
-  Alternative Solution
-  Excess Inventory Management