

ISO77xxD/ISO70xxD Single- and Dual-Digital Isolator Evaluation Module

This user's guide describes the ISO77xxD/ISO70xxD single- and dual-digital isolator evaluation module (EVM). This EVM lets designers evaluate device performance for fast development and analysis of isolated systems. The EVM supports evaluation of any of the TI single- or dual-channel digital isolators in an 8-pin SOIC (D) package.

CAUTION

This evaluation module is made available for isolator parameter performance evaluation only and is not intended for isolation voltage testing. To prevent damage to the EVM, any voltage applied as a supply or digital input/output must be maintained within the 0 V to 5.5 V recommended operating range.

Contents

1	Introduction	2
2	Overview	2
3	Pin Configurations of the ISO77xxD/ISO70xxD Single- and Dual-Channel Digital Isolators	2
4	ISO7721DEVM Board Block Diagram and Image	3
5	EVM Setup and Operation.....	4
6	Bill of Materials	5
7	EVM Schematics and Layout	5

List of Figures

1	ISO7710/ISO701x Single-Channel Digital Isolator Pin Configuration.....	2
2	ISO772x/ISO702x Dual-Channel Digital Isolator Pin Configurations	2
3	ISO7721/ISO7021 EVM Configuration.....	3
4	ISO77xxD/ISO70xxD-EVM Photograph	3
5	Basic EVM Operation	4
6	Typical Input and Output Waveform.....	4
7	ISO77xxD/ISO70xxD EVM Schematic.....	5
8	ISO77xxD/ISO70xxD PCB Layout.....	6

List of Tables

1	Bill of Materials	5
---	-------------------------	---

Trademarks

All trademarks are the property of their respective owners.

1 Introduction

This user's guide describes EVM operation with respect to the ISO77xxD/ISO70xxD single- and dual-channel digital isolators. However, the EVM may be reconfigured for evaluation of any of TI's single- or dual-channel digital isolators in an 8-pin SOIC (D) package. This guide also describes the available channel configurations within the ISO77xxD/ISO70xxD family, the EVM schematic, and typical laboratory setup. A typical input and output waveform is also presented.

2 Overview

The ISO77xxD/ISO70xxD is TI's new digital isolator family capable of galvanic isolations up to 4242 V_{PK}. The devices are certified to meet reinforced isolation requirements by VDE and CSA. These isolators provide high electromagnetic immunity and low emissions at low power consumption, while isolating CMOS or LVCMOS digital I/Os. The ISO77xxD/ISO70xxD digital isolators have logic input and output buffers separated by a silicon oxide (SiO₂) insulation barrier. Used with isolated power supplies, these devices block high voltages, isolate grounds, and prevent noise currents on a data bus or other circuits from entering the local ground and interfering with, or damaging sensitive circuitry.

3 Pin Configurations of the ISO77xxD/ISO70xxD Single- and Dual-Channel Digital Isolators

Figure 1 shows the ISO7710/ISO701x single-channel digital isolator pin configuration.

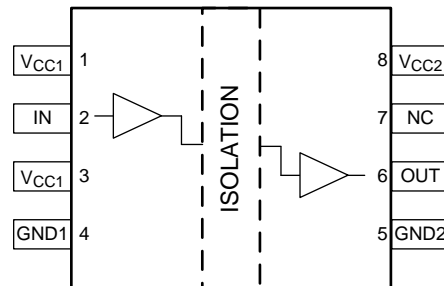

Figure 1. ISO7710/ISO701x Single-Channel Digital Isolator Pin Configuration

Figure 2 shows the ISO772x dual-channel digital isolator pin configurations.

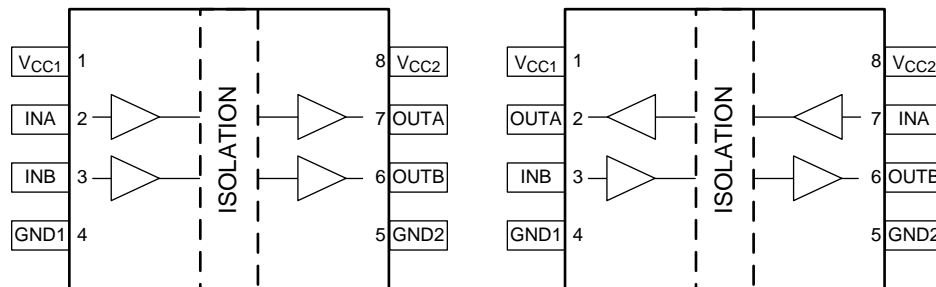

Figure 2. ISO772x/ISO702x Dual-Channel Digital Isolator Pin Configurations

4 ISO7721DEVM Board Block Diagram and Image

Figure 3 shows the board configuration for evaluation of the ISO7721/ISO7021 dual-channel digital isolator.

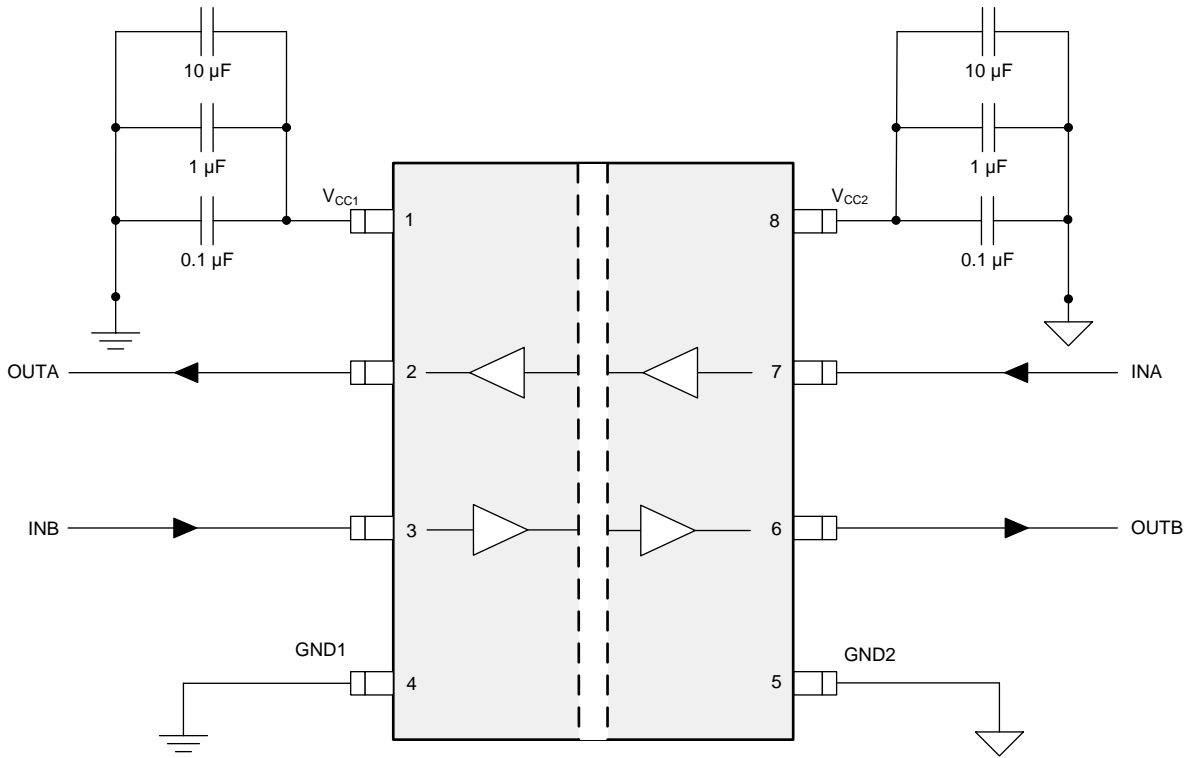

Figure 3. ISO7721/ISO7021 EVM Configuration

Figure 4 shows the photograph of the EVM.

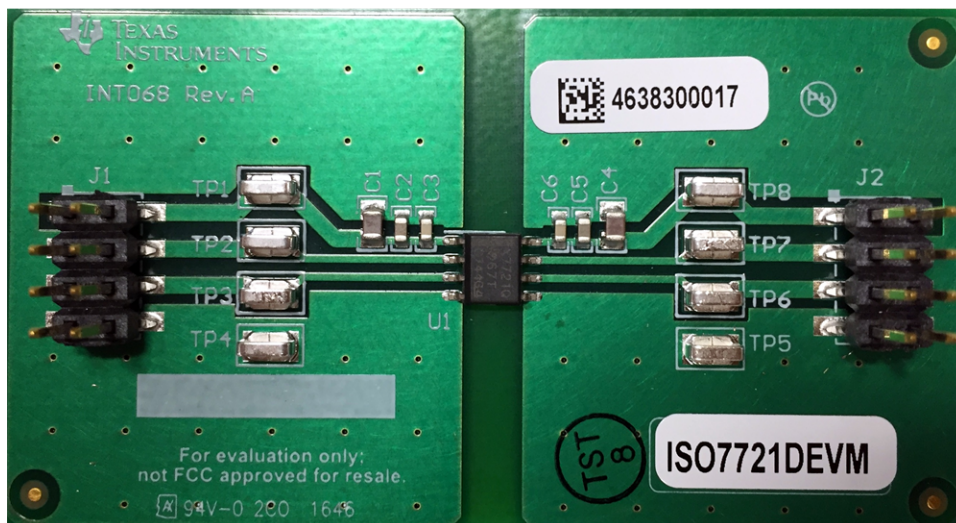

Figure 4. ISO77xxD/ISO70xxD-EVM Photograph

5 EVM Setup and Operation

This section describes the setup and operation of the EVM for parameter performance evaluation.

[Figure 5](#) shows the configuration for operating the ISO77xxD/ISO70xxD single- and dual-digital isolator EVM using two power supplies.

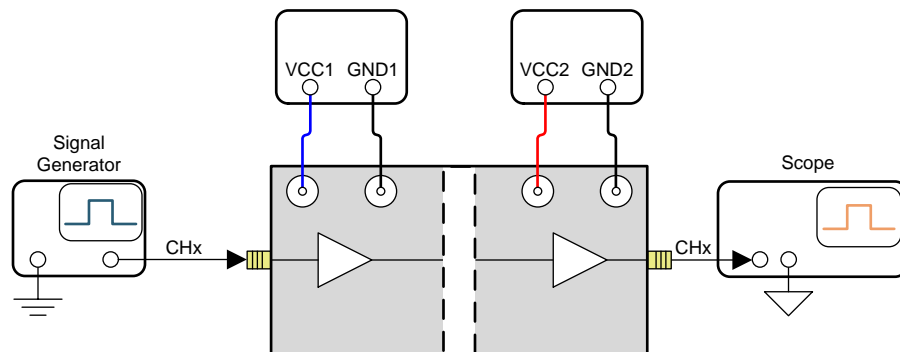

Figure 5. Basic EVM Operation

[Figure 6](#) shows typical input and output waveforms of the EVM for a 1-MHz clock. The input is shown as channel 1, and the output is shown as channel 2.

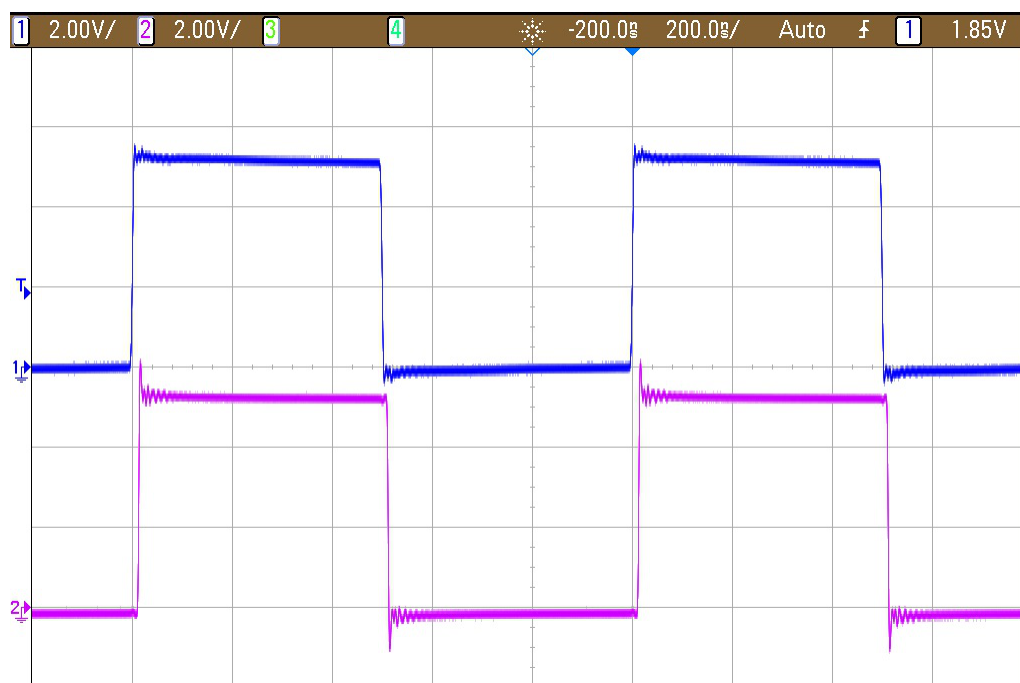

Figure 6. Typical Input and Output Waveform

6 Bill of Materials

Table 1 shows the bill of materials (BOM) for this EVM.

Table 1. Bill of Materials

Item	Designator	Description	Manufacturer	Part Number	Quantity
1	C1, C4	CAP, CERM, 10 μ F, 35 V, \pm 10%, X5R, 0805	MuRata	GRM21BR6YA106KE43L	2
2	C2, C5	CAP, CERM, 1 μ F, 50 V, \pm 10%, X5R, 0603	MuRata	GRM188R61H105KAALD	2
3	C3, C6	CAP, CERM, 0.1 μ F, 25 V, \pm 5%, X7R, 0603	AVX	06033C104JAT2A	2
4	H1, H2, H3, H4	Bumpon, Hemisphere, 0.44 X 0.20, Clear	3M	SJ-5303 (CLEAR)	4
5	J1, J2	Header, 100mil, 4x2, Gold, SMT	Molex	15910080	2
6	TP1, TP2, TP3, TP4, TP5, TP6, TP7, TP8	Test Point, Miniature, SMT	Keystone	5019	8
7	U1	Robust EMC, Low Power, Dual-Channel Digital Isolators, D0008B (SOIC-8)	Texas Instruments	ISO7721DR	1

7 EVM Schematics and Layout

The ISO7721DEVM is designed to accommodate any of the ISO77xxD/ISO70xxD single- and dual-channel devices in an 8-pin D package. To evaluate any of the ISO77xxD/ISO70xxD single- and dual-channel devices in an 8-pin D package, replace ISO7721D with the device of interest on the ISO7721DEVM PCB. No other component requires any modification. Figure 7 shows the ISO77xxD/ISO70xxD EVM schematic and Figure 8 shows the printed-circuit board (PCB) layout.

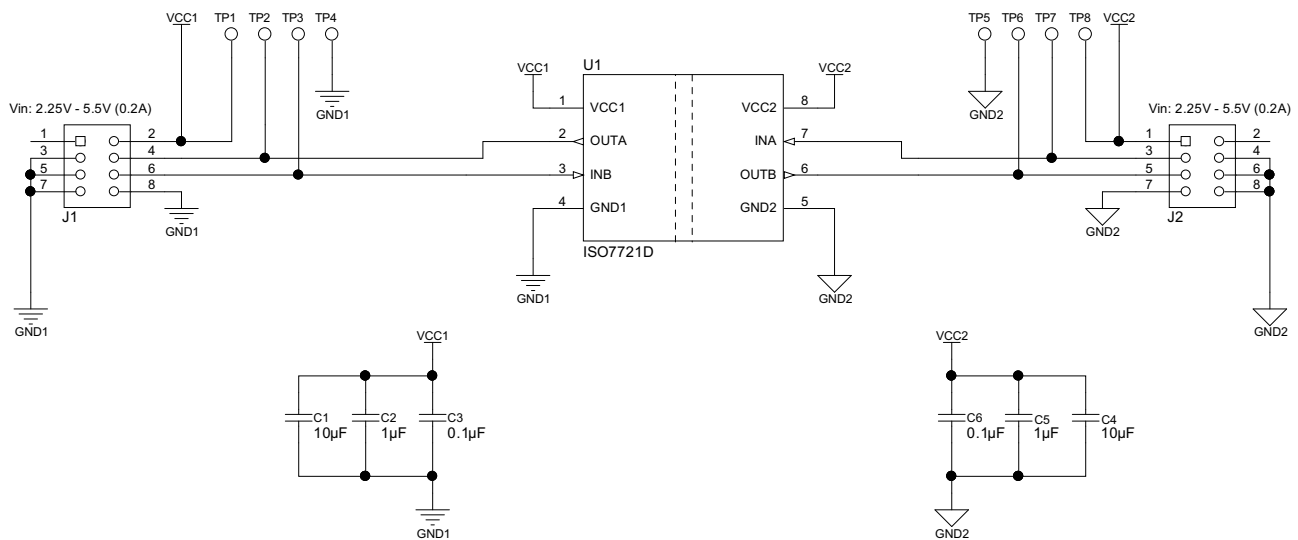

Copyright © 2016, Texas Instruments Incorporated

Figure 7. ISO77xxD/ISO70xxD EVM Schematic

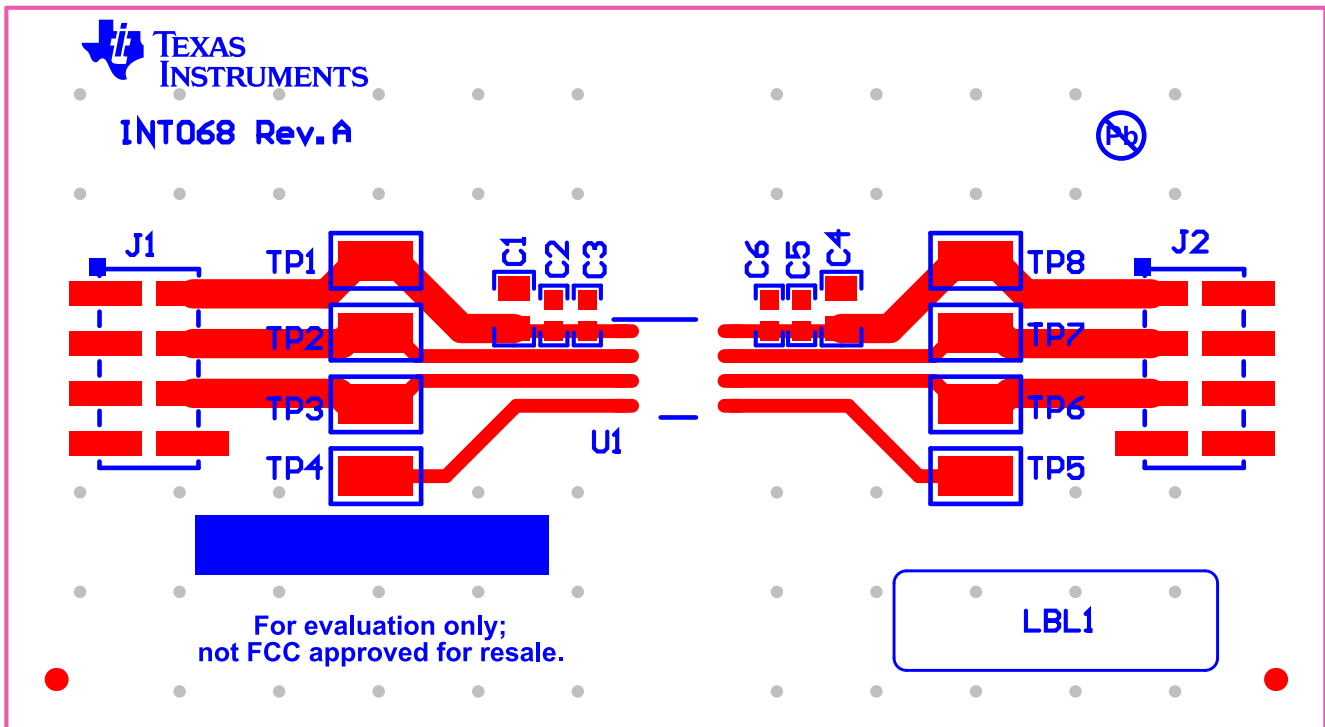

Figure 8. ISO77xxD/ISO70xxD PCB Layout

IMPORTANT NOTICE AND DISCLAIMER

TI PROVIDES TECHNICAL AND RELIABILITY DATA (INCLUDING DATA SHEETS), DESIGN RESOURCES (INCLUDING REFERENCE DESIGNS), APPLICATION OR OTHER DESIGN ADVICE, WEB TOOLS, SAFETY INFORMATION, AND OTHER RESOURCES "AS IS" AND WITH ALL FAULTS, AND DISCLAIMS ALL WARRANTIES, EXPRESS AND IMPLIED, INCLUDING WITHOUT LIMITATION ANY IMPLIED WARRANTIES OF MERCHANTABILITY, FITNESS FOR A PARTICULAR PURPOSE OR NON-INFRINGEMENT OF THIRD PARTY INTELLECTUAL PROPERTY RIGHTS.

These resources are intended for skilled developers designing with TI products. You are solely responsible for (1) selecting the appropriate TI products for your application, (2) designing, validating and testing your application, and (3) ensuring your application meets applicable standards, and any other safety, security, regulatory or other requirements.

These resources are subject to change without notice. TI grants you permission to use these resources only for development of an application that uses the TI products described in the resource. Other reproduction and display of these resources is prohibited. No license is granted to any other TI intellectual property right or to any third party intellectual property right. TI disclaims responsibility for, and you will fully indemnify TI and its representatives against, any claims, damages, costs, losses, and liabilities arising out of your use of these resources.

TI's products are provided subject to [TI's Terms of Sale](#) or other applicable terms available either on ti.com or provided in conjunction with such TI products. TI's provision of these resources does not expand or otherwise alter TI's applicable warranties or warranty disclaimers for TI products.

TI objects to and rejects any additional or different terms you may have proposed.

Mailing Address: Texas Instruments, Post Office Box 655303, Dallas, Texas 75265
Copyright © 2022, Texas Instruments Incorporated

Looking for pricing, stock, or lifecycle information?

Click below to explore more details on WIN SOURCE:

 [View ISO7721DEVM](#) on WIN SOURCE

 [Texas Instruments](#) Information

Optimize Your Supply Chain with WIN SOURCE Solutions

-  Global Sourcing Solution
-  Obsolete Management
-  Cost Control Management
-  Shortage Management
-  Alternative Solution
-  Excess Inventory Management