



THE DATASHEET OF DC513A



QUICK START GUIDE FOR DEMONSTRATION CIRCUIT 513

SOFTWARE-SELECTABLE MULTI-PROTOCOL TRANSCEIVER

LTC2846CG/LTC2845CG

DESCRIPTION

Demonstration circuit 513 is a complete DCE or DTE serial port. The protocols supported are V.28 (RS232), V.35, V.36, RS449, EIA530, EIA530A and X.21. Six jumpers select the proper protocol and other port-configuration settings. One jumper turns on/off the internal switching regulator of the LTC[®]2846. The board provides a vehicle for observing the line drivers and receivers on the LTC2846 and LTC2845. Logic-level signals enter and exit the board on the left side and line-level signals enter and exit on the right. The internally generated supplies are observable on the pins at the top of the board.

DC513 is intended for network equipment that interfaces to other equipment using standard serial connections. These applications include routers and wide area networks. The interface design work is as simple as placing this chipset on a board with a handful of small, inexpensive components.

Design files for this circuit board are available. Call the LTC factory.

LTC is a trademark of Linear Technology Corporation

QUICK START GUIDE FOR DEMONSTRATION CIRCUIT 513

SOFTWARE-SELECTABLE MULTI-PROTOCOL TRANSCEIVER

Table 1. Performance Summary ($T_A = 25^\circ\text{C}$)

| PARAMETER | CONDITION | VALUE |
|---|-----------------------------------|------------------|
| Input Voltage | With Onboard Boost Regulator | 3.3V |
| | Without Boost Regulator | 5.0V |
| I_{CC} | No Cable Mode | 300 μ A |
| $I_{shutdown}$ | Boost Regulator Quiescent Current | 10nA |
| $V_{quiescent}$ | Boost Regulator Not Switching | 4.2mA |
| Logic Level Hi | D1,D2,D3,M0,M1,M2,DCE/DTE | 2.0V |
| | SHDN | 2.4V |
| Logic Level Low | D1,D2,D3,M0,M1,M2,DCE/DTE | 0.8V |
| | SHDN | 0.5V |
| Receiver Differential Input Impedance | V.11 | 103 Ω |
| | V.35 | 90-110 Ω |
| | V.28 | 3-7K Ω |
| Receiver Common Mode Input Impedance | V.35 | 135-165 Ω |
| Transmitter Differential Mode Impedance | V.35 | 50-150 Ω |
| Transmitter Common Mode Impedance | V.35 | 135-165 Ω |
| Driver T_r , T_f | V.11 | 15ns |
| | V.35 | 5ns |
| Driver Slew Rate | V.28 | 4-30V/ μ s |
| Receiver Input Hysteresis | V.11 | 15mV |
| | V.35 | 15mV |
| | V.28 | 50mV |

QUICK START PROCEDURE

1. Connect the input voltage power supply, meters, pulse generator and oscilloscope as shown in Figure 1.
2. The pulse generator should be set to a 0V to 3.3V swing.
3. $\overline{\text{SHDN}}$ should be set to ' 1 ' to turn on the internal switching regulator of the LTC2846
4. The mode pins M0, M1 and M2, plus the configuration pin DCE/DTE should be configured for the desired protocol and port setting. (M0 = 0, M1 = 1, M2 = 0 and DCE/DTE = 0 selects the RS530 DTE mode)
5. Observe the waveforms on the logic signal side and the line signal side of the board. The line driver (TXDA, TXDB) is connected to the line receiver (RXCA, RXCB) to demonstrate the line signals. RTS is also connected to DSR.
6. Observe the internally generated supplies (V_{CC} , V_{EE} and V_{DD})

QUICK START GUIDE FOR DEMONSTRATION CIRCUIT 513

SOFTWARE-SELECTABLE MULTI-PROTOCOL TRANSCEIVER

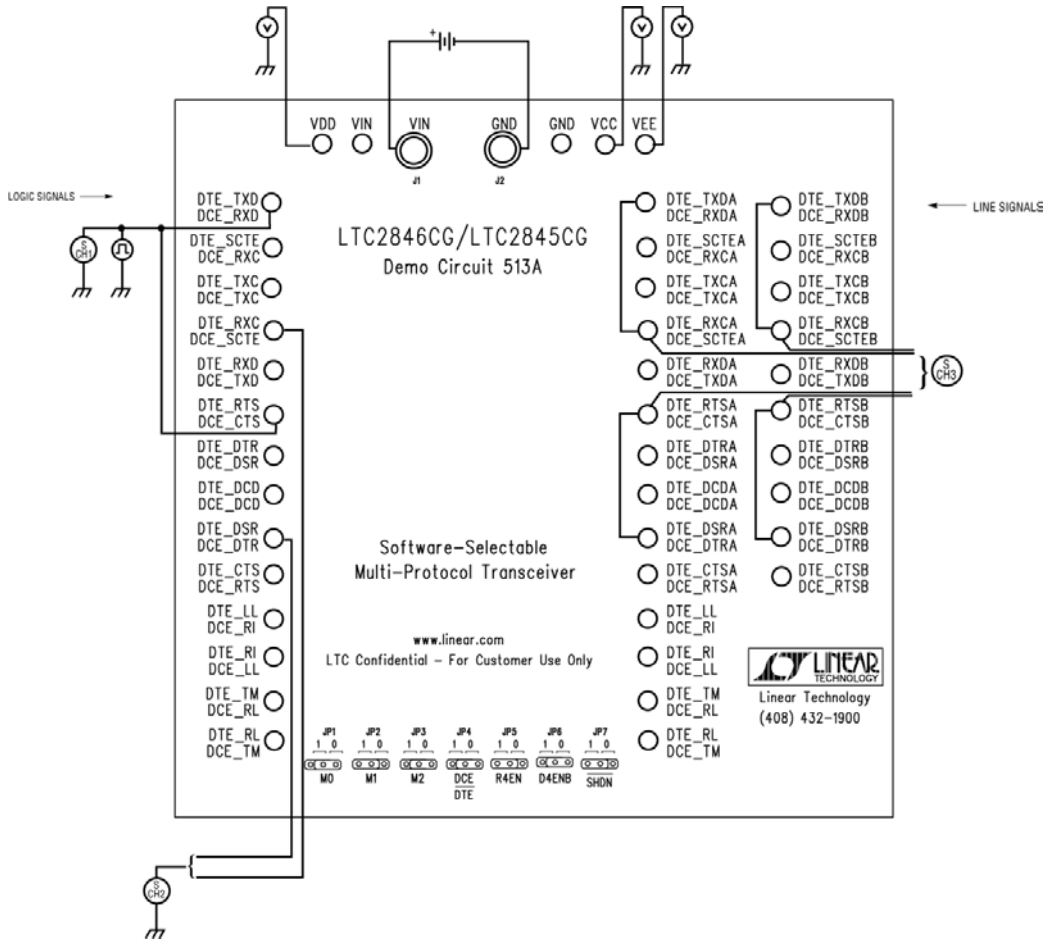
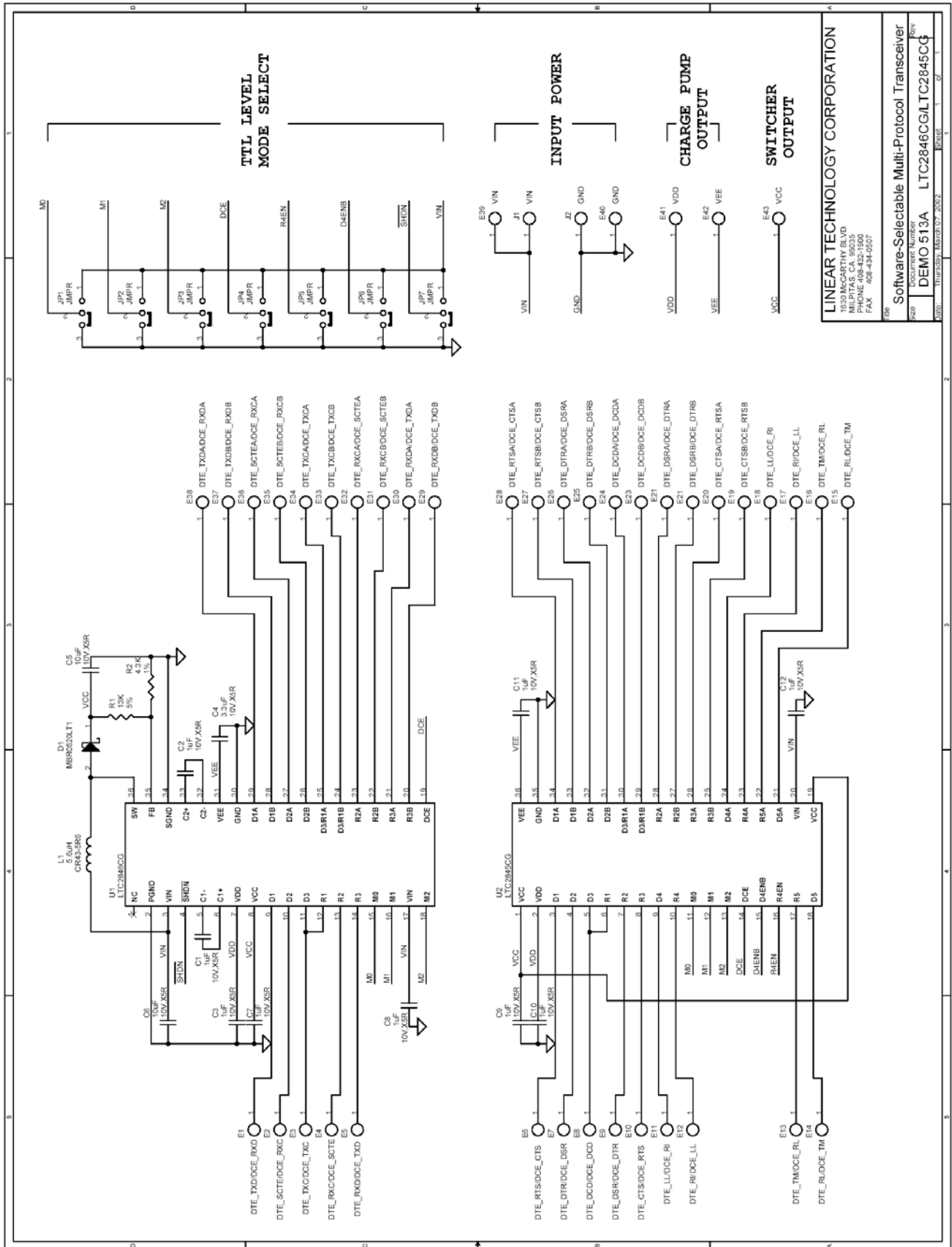

Figure 1. Proper Measurement Equipment Setup



QUICK START GUIDE FOR DEMONSTRATION CIRCUIT 513

SOFTWARE-SELECTABLE MULTI-PROTOCOL TRANSCEIVER



Looking for pricing, stock, or lifecycle information?

Click below to explore more details on WIN SOURCE:

-  [View DC513A on WIN SOURCE](#)
-  [Analog Devices Inc. Information](#)

Optimize Your Supply Chain with WIN SOURCE Solutions

-  Global Sourcing Solution
-  Obsolete Management
-  Cost Control Management
-  Shortage Management
-  Alternative Solution
-  Excess Inventory Management