



**THE DATASHEET OF  
LT3470HTS8#TRMPBF**



# Micropower Buck Regulator with Integrated Boost and Catch Diodes

## FEATURES

- **Low Quiescent Current: 26µA at 12V<sub>IN</sub> to 3.3V<sub>OUT</sub>**
- **Integrated Boost and Catch Diodes**
- **Input Range: 4V to 40V**
- **Low Output Ripple: <10mV**
- <1µA in Shutdown Mode
- Output Voltage: 1.25V to 16V
- 200mA Output Current
- Hysteretic Mode Control
  - Low Ripple Burst Mode® Operation at Light Loads
  - Continuous Operation at Higher Loads
- Solution Size as Small as 50mm<sup>2</sup>
- Low Profile (0.75mm) 3mm × 2mm Thermally Enhanced 8-Lead DD and 1mm ThinSOT Packages
- AEC-Q100 Qualified for Automotive Applications

## APPLICATIONS

- Automotive Battery Regulation
- Power for Portable Products
- Distributed Supply Regulation
- Industrial Supplies
- Wall Transformer Regulation

## DESCRIPTION

The **LT®3470** is a micropower step-down DC/DC converter that integrates a 300mA power switch, catch diode and boost diode into low profile 3mm × 2mm DD and ThinSOT™ packages. The LT3470 combines Burst Mode and continuous operation to allow the use of tiny inductor and capacitors while providing a low ripple output to loads of up to 200mA.

With its wide input range of 4V to 40V, the LT3470 can regulate a wide variety of power sources, from 2-cell Li-Ion batteries to unregulated wall transformers and lead-acid batteries. Quiescent current in regulation is just 26µA in a typical application while a zero current shutdown mode disconnects the load from the input source, simplifying power management in battery-powered systems. Fast current limiting and hysteretic control protects the LT3470 and external components against shorted outputs, even at 40V input.

All registered trademarks and trademarks are the property of their respective owners.

## TYPICAL APPLICATION

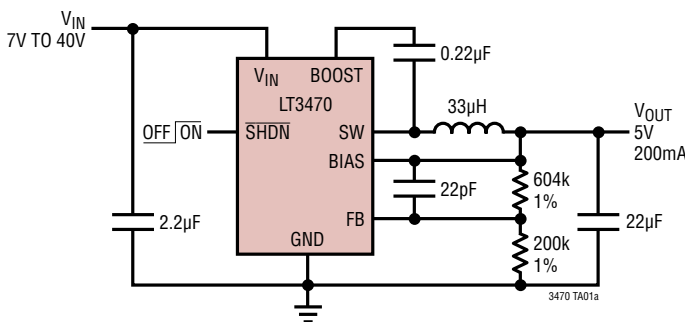

Efficiency and Power Loss vs Load Current

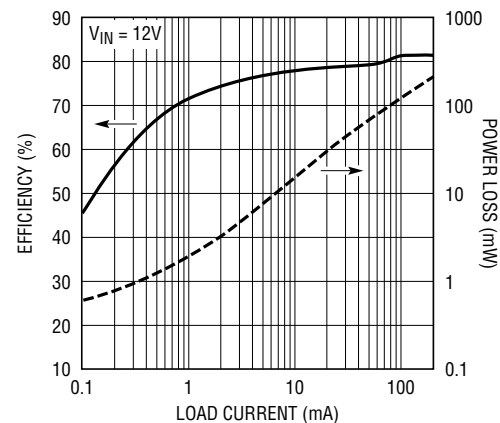

3470 TA02

# LT3470

## ABSOLUTE MAXIMUM RATINGS (Note 1)

|                               |          |  |                |
|-------------------------------|----------|--|----------------|
| $V_{IN}$ , SHDN Voltage ..... | 40V      | Operating Temperature Range (Note 2)       |                |
| BOOST Pin Voltage .....       | 47V      | LT3470E.....                               | -40°C to 85°C  |
| BOOST Pin Above SW Pin.....   | 25V      | LT3470I .....                              | -40°C to 125°C |
| FB Voltage.....               | 5V       | LT3470H .....                              | -40°C to 150°C |
| BIAS Voltage.....             | 25V      | Storage Temperature Range .....            | -65°C to 150°C |
| SW Voltage .....              | $V_{IN}$ | Lead Temperature (Soldering, 10 sec) ..... | 300°C          |
| Maximum Junction Temperature  |          |  |                |
| LT3470E, LT3470I.....         | 125°C    |  |                |
| LT3470H .....                 | 150°C    |  |                |

## PIN CONFIGURATION

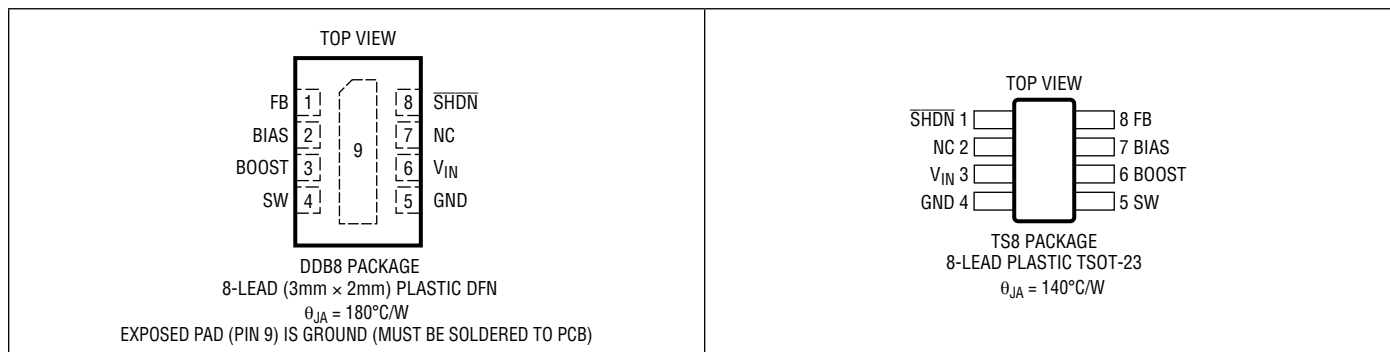

## ORDER INFORMATION

| LEAD FREE FINISH  | TAPE AND REEL    | PART MARKING | PACKAGE DESCRIPTION            | TEMPERATURE RANGE |
|-------------------|------------------|--------------|--------------------------------|-------------------|
| LT3470EDDB#TRMPBF | LT3470EDDB#TRPBF | LBPN         | 8-Lead (3mm × 2mm) Plastic DFN | -40°C to 85°C     |
| LT3470IDDB#TRMPBF | LT3470IDDB#TRPBF | LBPP         | 8-Lead (3mm × 2mm) Plastic DFN | -40°C to 125°C    |
| LT3470HDDB#TRMPBF | LT3470HDDB#TRPBF | LCNR         | 8-Lead (3mm × 2mm) Plastic DFN | -40°C to 150°C    |
| LT3470ETS8#PBF    | LT3470ETS8#TRPBF | LTBDM        | 8-Lead Plastic TSOT-23         | -40°C to 85°C     |
| LT3470ITS8#PBF    | LT3470ITS8#TRPBF | LTBPW        | 8-Lead Plastic TSOT-23         | -40°C to 125°C    |
| LT3470HTS8#PBF    | LT3470HTS8#TRPBF | LTCNQ        | 8-Lead Plastic TSOT-23         | -40°C to 150°C    |
| LEAD BASED FINISH | TAPE AND REEL    | PART MARKING | PACKAGE DESCRIPTION            | TEMPERATURE RANGE |
| LT3470EDDB        | LT3470EDDB#TR    | LBPN         | 8-Lead (3mm × 2mm) Plastic DFN | -40°C to 85°C     |
| LT3470IDDB        | LT3470IDDB#TR    | LBPP         | 8-Lead (3mm × 2mm) Plastic DFN | -40°C to 125°C    |
| LT3470HDDB        | LT3470HDDB#TR    | LCNR         | 8-Lead (3mm × 2mm) Plastic DFN | -40°C to 150°C    |
| LT3470ETS8        | LT3470ETS8#TR    | LTBDM        | 8-Lead Plastic TSOT-23         | -40°C to 85°C     |
| LT3470ITS8        | LT3470ITS8#TR    | LTBPW        | 8-Lead Plastic TSOT-23         | -40°C to 125°C    |
| LT3470HTS8        | LT3470HTS8#TR    | LTCNQ        | 8-Lead Plastic TSOT-23         | -40°C to 150°C    |

## ORDER INFORMATION

### AUTOMOTIVE PRODUCTS\*\*

|                    |                   |      |                                |                |
|--------------------|-------------------|------|--------------------------------|----------------|
| LT3470EDDB#WTRMPBF | LT3470EDDB#WTRPBF | LBPN | 8-Lead (3mm × 2mm) Plastic DFN | −40°C to 85°C  |
| LT3470IDDB#WTRMPBF | LT3470IDDB#WTRPBF | LBPP | 8-Lead (3mm × 2mm) Plastic DFN | −40°C to 125°C |
| LT3470HDB#WTRMPBF  | LT3470HDB#WTRPBF  | LCNR | 8-Lead (3mm × 2mm) Plastic DFN | −40°C to 150°C |

Contact the factory for parts specified with wider operating temperature ranges. \*The temperature grade is identified by a label on the shipping container.

**Tape and reel specifications.** Some packages are available in 500 unit reels through designated sales channels with #TRMPBF suffix.

\*\*Versions of this part are available with controlled manufacturing to support the quality and reliability requirements of automotive applications. These models are designated with a #W suffix. Only the automotive grade products shown are available for use in automotive applications. Contact your local Analog Devices account representative for specific product ordering information and to obtain the specific Automotive Reliability reports for these models.

## ELECTRICAL CHARACTERISTICS

The ● denotes the specifications which apply over the full operating temperature range, otherwise specifications are at  $T_A = 25^\circ\text{C}$ .  $V_{IN} = 10\text{V}$ ,  $V_{SHDN} = 10\text{V}$ ,  $V_{BOOST} = 15\text{V}$ ,  $V_{BIAS} = 3\text{V}$  unless otherwise specified.

| PARAMETER                        | CONDITIONS                                     | MIN | TYP    | MAX   | UNITS         |    |
|----------------------------------|--|-----|--------|-------|---------------|----|
| Minimum Input Voltage            |  | ●   |        | 4     | V             |    |
| Quiescent Current from $V_{IN}$  | $V_{SHDN} = 0.2\text{V}$                       | ●   | 0.1    | 0.5   | $\mu\text{A}$ |    |
|                                  | $V_{BIAS} = 3\text{V}$ , Not Switching         | ●   | 10     | 18    | $\mu\text{A}$ |    |
|                                  | $V_{BIAS} = 0\text{V}$ , Not Switching         |     | 35     | 50    | $\mu\text{A}$ |    |
| Quiescent Current from Bias      | $V_{SHDN} = 0.2\text{V}$                       | ●   | 0.1    | 0.5   | $\mu\text{A}$ |    |
|                                  | $V_{BIAS} = 3\text{V}$ , Not Switching         | ●   | 25     | 60    | $\mu\text{A}$ |    |
|                                  | $V_{BIAS} = 0\text{V}$ , Not Switching         |     | 0.1    | 1.5   | $\mu\text{A}$ |    |
| FB Comparator Trip Voltage       | $V_{FB}$ Falling                               | ●   | 1.228  | 1.250 | 1.265         | V  |
| FB Pin Bias Current (Note 3)     | $V_{FB} = 1\text{V}$ , E- and I-Grade          | ●   |        | 35    | 80            | nA |
|                                  |  | ●   |        | 35    | 150           | nA |
|                                  | H-Grade  | ●   |        | 35    | 225           | nA |
| FB Voltage Line Regulation       | $4\text{V} < V_{IN} < 40\text{V}$              |     | 0.0006 | 0.01  | %/V           |    |
| Minimum Switch Off-Time (Note 5) |  |     | 500    |       | ns            |    |
| Switch Leakage Current           |  |     | 0.7    | 1.5   | $\mu\text{A}$ |    |
| Switch $V_{CESAT}$               | $I_{SW} = 100\text{mA}$ (TS8 Package)          |     | 215    | 300   | mV            |    |
|                                  | $I_{SW} = 100\text{mA}$ (DD8 Package)          |     | 215    |       | mV            |    |
| Switch Top Current Limit         | $V_{FB} = 0\text{V}$                           |     | 250    | 325   | 435           | mA |
| Switch Bottom Current Limit      | $V_{FB} = 0\text{V}$                           |     | 225    |       | mA            |    |
| Catch Schottky Drop              | $I_{SH} = 100\text{mA}$ (TS8 Package)          |     | 630    | 775   | mV            |    |
|                                  | $I_{SH} = 100\text{mA}$ (DD8 Package)          |     | 630    |       | mV            |    |
| Catch Schottky Reverse Leakage   | $V_{SW} = 10\text{V}$                          |     | 0.2    | 2     | $\mu\text{A}$ |    |
| Boost Schottky Drop              | $I_{SH} = 30\text{mA}$                         |     | 650    | 775   | mV            |    |
| Boost Schottky Reverse Leakage   | $V_{SW} = 10\text{V}$ , $V_{BIAS} = 0\text{V}$ |     | 0.2    | 2     | $\mu\text{A}$ |    |
| Minimum Boost Voltage (Note 4)   |  | ●   | 1.7    | 2.2   | V             |    |
| BOOST Pin Current                | $I_{SW} = 100\text{mA}$                        |     | 7      | 12    | mA            |    |
| SHDN Pin Current                 | $V_{SHDN} = 2.5\text{V}$                       |     | 1      | 5     | $\mu\text{A}$ |    |
| SHDN Input Voltage High          |  |     | 2.5    |       | V             |    |
| SHDN Input Voltage Low           |  |     |        | 0.2   | V             |    |

## ELECTRICAL CHARACTERISTICS

**Note 1:** Stresses beyond those listed under Absolute Maximum Ratings may cause permanent damage to the device. Exposure to any Absolute Maximum Rating condition for extended periods may affect device reliability and lifetime.

**Note 2:** The LT3470E is guaranteed to meet performance specifications from 0°C to 85°C. Specifications over the -40°C to 85°C operating temperature range are assured by design, characterization and correlation with statistical process controls. The LT3470I specifications

are guaranteed over the -40°C to 125°C temperature range. LT3470H specifications are guaranteed over -40°C to 150°C temperature range.

**Note 3:** Bias current flows out of the FB pin.

**Note 4:** This is the minimum voltage across the boost capacitor needed to guarantee full saturation of the switch.

**Note 5:** This parameter is assured by design and correlation with statistical process controls.

## TYPICAL PERFORMANCE CHARACTERISTICS

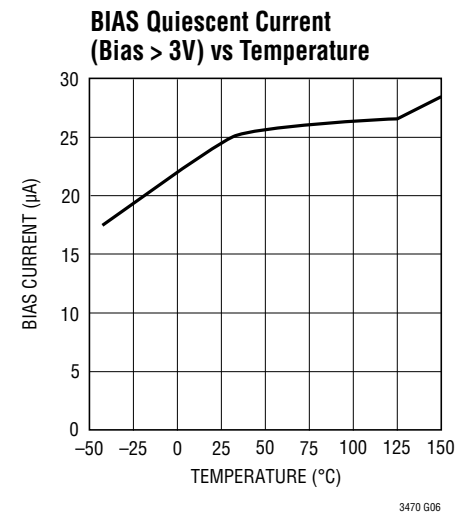
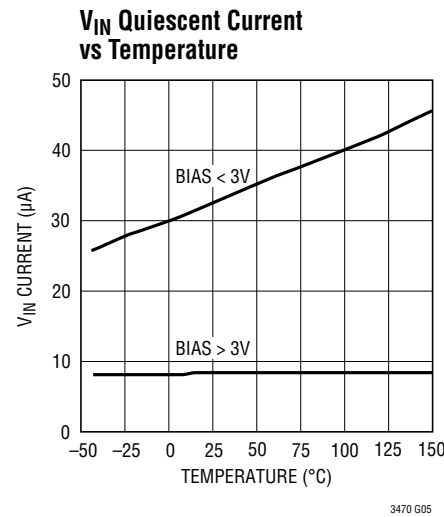
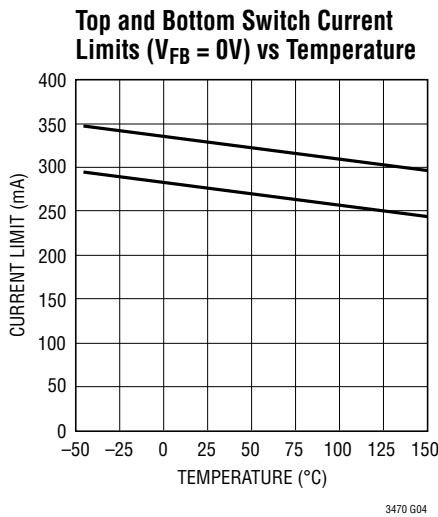
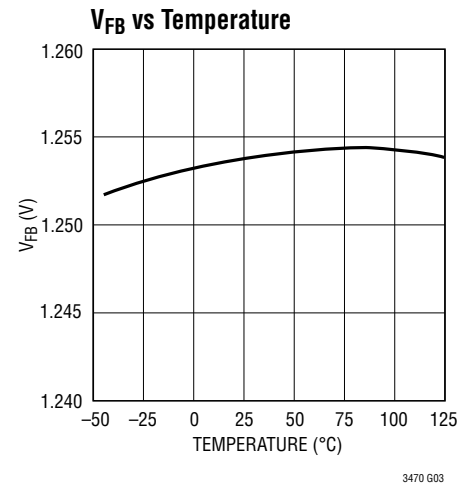
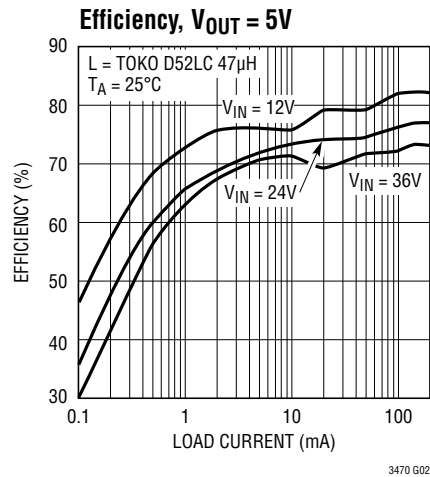
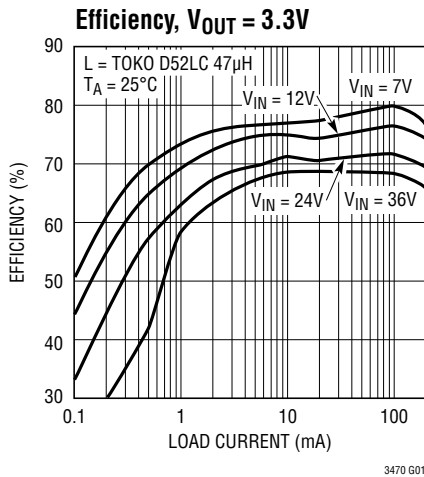

# TYPICAL PERFORMANCE CHARACTERISTICS

**SHDN Bias Current vs Temperature**

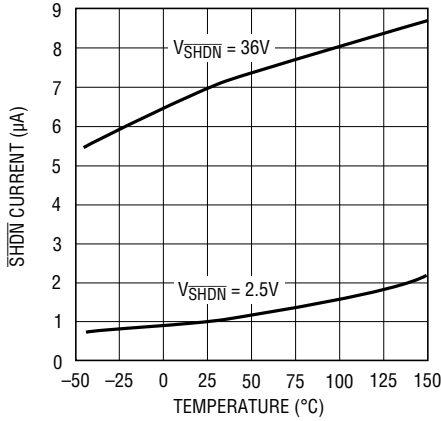

3470 G07

**FB Bias Current ( $V_{FB} = 1V$ ) vs Temperature**

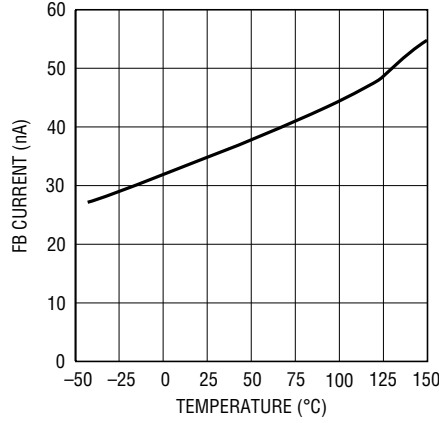

3470 G08

**FB Bias Current ( $V_{FB} = 0V$ ) vs Temperature**

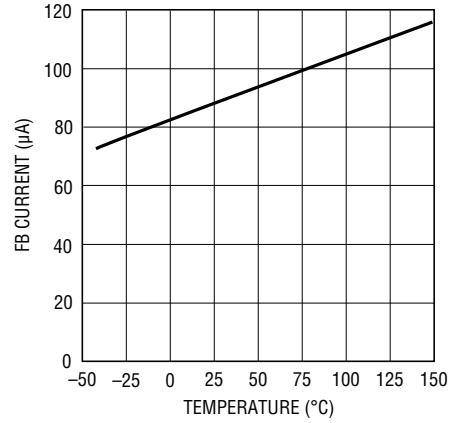

3470 G09

**Switch  $V_{CESAT}$  ( $I_{SW} = 100mA$ ) vs Temperature**

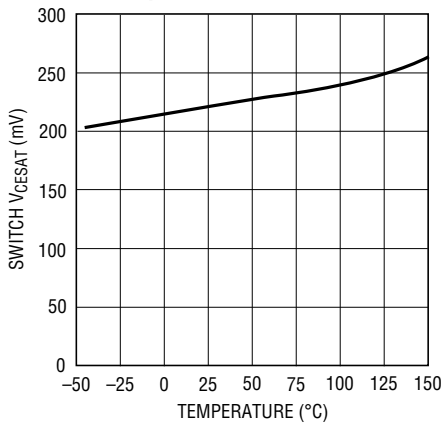

3470 G10

**Boost Diode  $V_F$  ( $I_F = 50mA$ ) vs Temperature**

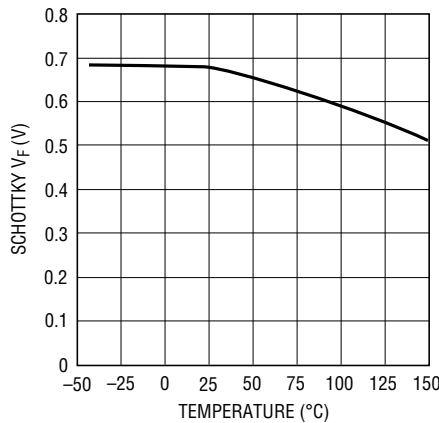

3470 G11

**Catch Diode  $V_F$  ( $I_F = 100mA$ ) vs Temperature**

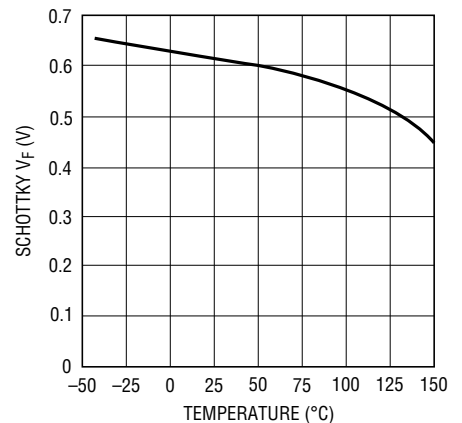

3470 G12

**Diode Leakage ( $V_R = 36V$ ) vs Temperature**

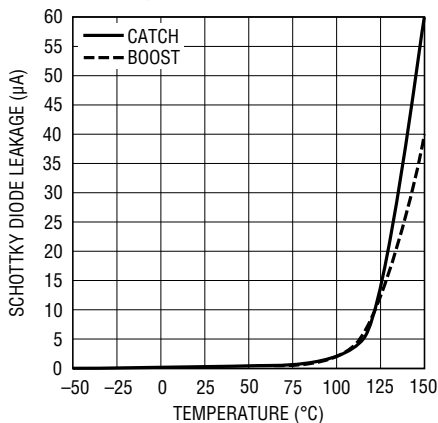

3470 G13

**Switch  $V_{CESAT}$**

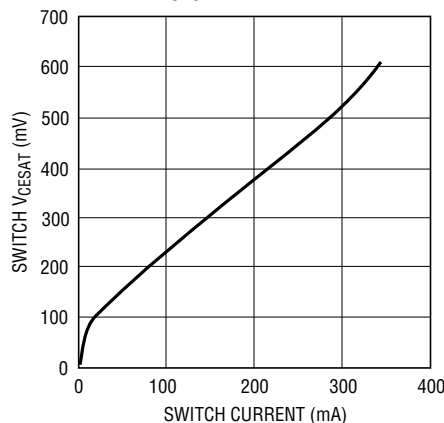

3470 G14

**BOOST Pin Current**

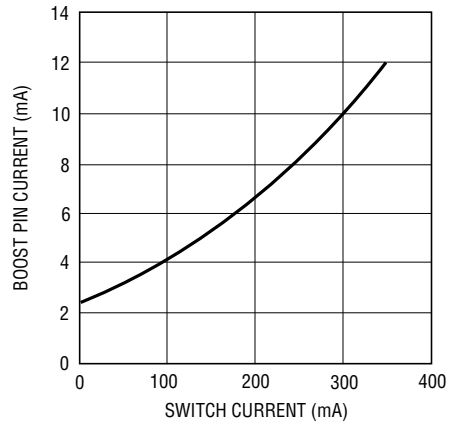

3470 G15

**TYPICAL PERFORMANCE CHARACTERISTICS**

**Catch Diode Forward Voltage**

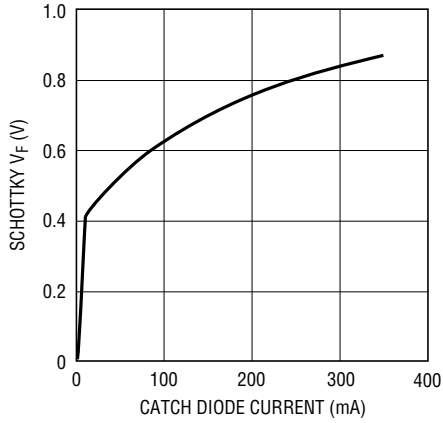

3470 G16

**Boost Diode Forward Voltage**

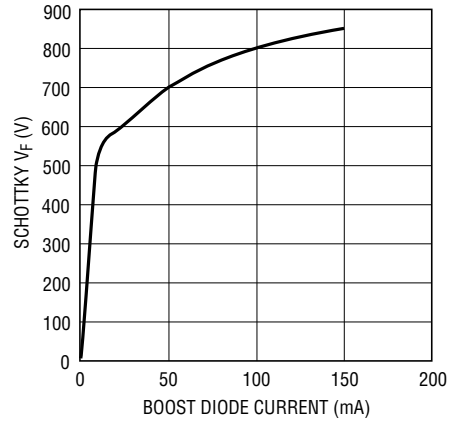

3470 G17

**Minimum Input Voltage,  $V_{OUT} = 3.3V$**

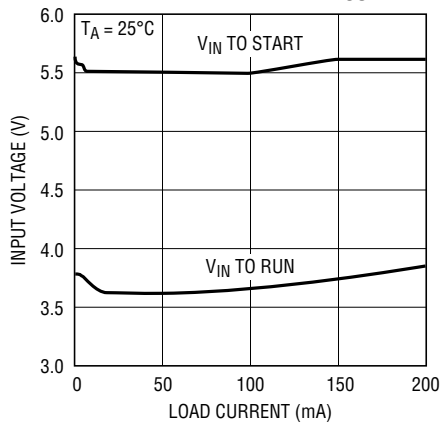

3470 G18

**Minimum Input Voltage,  $V_{OUT} = 5V$**

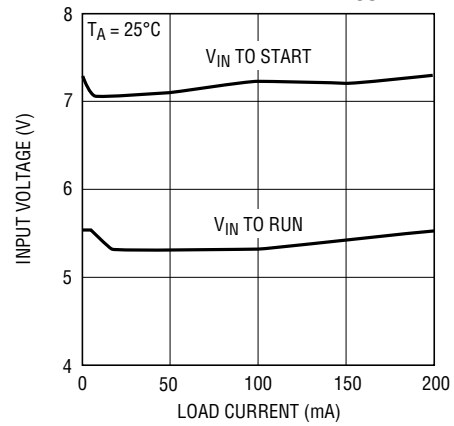

3470 G19



## OPERATION

The LT3470 uses a hysteretic control scheme in conjunction with Burst Mode operation to provide low output ripple and low quiescent current while using a tiny inductor and capacitors.

Operation can best be understood by studying the Block Diagram. An error amplifier measures the output voltage through an external resistor divider tied to the FB pin. If the FB voltage is higher than  $V_{REF}$ , the error amplifier will shut off all the high power circuitry, leaving the LT3470 in its micropower state. As the FB voltage falls, the error amplifier will enable the power section, causing the chip to begin switching, thus delivering charge to the output capacitor. If the load is light the part will alternate between micropower and switching states to keep the output in regulation (See Figure 1a). At higher loads the part will switch continuously while the error amp servos the top and bottom current limits to regulate the FB pin voltage to 1.25V (See Figure 1b).

The switching action is controlled by an RS latch and two current comparators as follows: The switch turns on, and the current through it ramps up until the top current

comparator trips and resets the latch causing the switch to turn off. While the switch is off, the inductor current ramps down through the catch diode. When both the bottom current comparator trips and the minimum off-time one-shot expires, the latch turns the switch back on thus completing a full cycle. The hysteretic action of this control scheme results in a switching frequency that depends on inductor value, input and output voltage. Since the switch only turns on when the catch diode current falls below threshold, the part will automatically switch slower to keep inductor current under control during start-up or short-circuit conditions.

The switch driver operates from either the input or from the BOOST pin. An external capacitor and internal diode is used to generate a voltage at the BOOST pin that is higher than the input supply. This allows the driver to fully saturate the internal bipolar NPN power switch for efficient operation.

If the  $\overline{SHDN}$  pin is grounded, all internal circuits are turned off and  $V_{IN}$  current reduces to the device leakage current, typically a few nA.

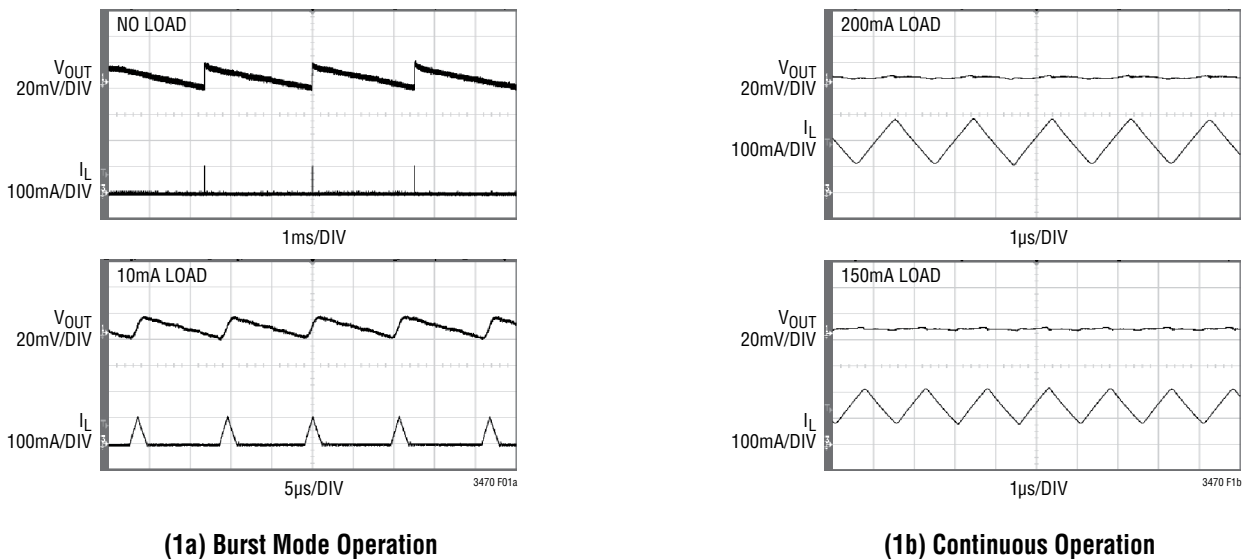

Figure 1. Operating Waveforms of the LT3470 Converting 12V to 5V Using a 33μH Inductor and 10μF Output Capacitor

## APPLICATIONS INFORMATION

### Input Voltage Range

The minimum input voltage required to generate a particular output voltage in an LT3470 application is limited by either its 4V undervoltage lockout or by its maximum duty cycle. The duty cycle is the fraction of time that the internal switch is on and is determined by the input and output voltages:

$$DC = \frac{V_{OUT} + V_D}{V_{IN} - V_{SW} + V_D}$$

where  $V_D$  is the forward voltage drop of the catch diode ( $\sim 0.6V$ ) and  $V_{SW}$  is the voltage drop of the internal switch at maximum load ( $\sim 0.4V$ ). Given  $DC_{MAX} = 0.90$ , this leads to a minimum input voltage of:

$$V_{IN(MIN)} = \left( \frac{V_{OUT} + V_D}{DC_{MAX}} \right) + V_{SW} - V_D$$

This analysis assumes the part has started up such that the capacitor tied between the BOOST and SW pins is charged to more than 2V. For proper start-up, the minimum input voltage is limited by the boost circuit as detailed in the section BOOST Pin Considerations.

The maximum input voltage is limited by the absolute maximum  $V_{IN}$  rating of 40V, provided an inductor of sufficient value is used.

### Inductor Selection

The switching action of the LT3470 during continuous operation produces a square wave at the SW pin that results in a triangle wave of current in the inductor. The hysteretic mode control regulates the top and bottom current limits (see Electrical Characteristics) such that the average inductor current equals the load current. For safe operation, it must be noted that the LT3470 cannot turn the switch on for less than  $\sim 150ns$ . If the inductor is small and the input voltage is high, the current through the switch may exceed safe operating limit before the LT3470 is able to turn off. To prevent this from happening, the following equation provides a minimum inductor value:

$$L_{MIN} = \frac{V_{IN(MAX)} \cdot t_{ON-TIME(MIN)}}{I_{MAX}}$$

where  $V_{IN(MAX)}$  is the maximum input voltage for the application,  $t_{ON-TIME(MIN)}$  is  $\sim 150ns$  and  $I_{MAX}$  is the maximum allowable increase in switch current during a minimum switch on-time (150mA). While this equation provides a safe inductor value, the resulting application circuit may switch at too high a frequency to yield good efficiency. It is advised that switching frequency be below 1.2MHz during normal operation:

$$f = \frac{(1-DC)(V_D + V_{OUT})}{L \cdot \Delta I_L}$$

where  $f$  is the switching frequency,  $\Delta I_L$  is the ripple current in the inductor ( $\sim 150mA$ ),  $V_D$  is the forward voltage drop of the catch diode, and  $V_{OUT}$  is the desired output voltage.

If the application circuit is intended to operate at high duty cycles ( $V_{IN}$  close to  $V_{OUT}$ ), it is important to look at the calculated value of the switch off-time:

$$t_{OFF-TIME} = \frac{1-DC}{f}$$

The calculated  $t_{OFF-TIME}$  should be more than LT3470's minimum  $t_{OFF-TIME}$  (See Electrical Characteristics), so the application circuit is capable of delivering full rated output current. If the full output current of 200mA is not required, the calculated  $t_{OFF-TIME}$  can be made less than minimum  $t_{OFF-TIME}$  possibly allowing the use of a smaller inductor. See Table 1 for an inductor value selection guide.

**Table 1. Recommended Inductors for Loads up to 200mA**

| $V_{OUT}$ | $V_{IN}$ UP TO 16V | $V_{IN}$ UP TO 40V |
|-----------|--------------------|--------------------|
| 2.5V      | 10 $\mu$ H         | 33 $\mu$ H         |
| 3.3V      | 10 $\mu$ H         | 33 $\mu$ H         |
| 5V        | 15 $\mu$ H         | 33 $\mu$ H         |
| 12V       | 33 $\mu$ H         | 47 $\mu$ H         |

Choose an inductor that is intended for power applications. Table 2 lists several manufacturers and inductor series.

For robust output short-circuit protection at high  $V_{IN}$  (up to 40V) use at least a 33 $\mu$ H inductor with a minimum 450mA saturation current. If short-circuit performance is not required, inductors with  $I_{SAT}$  of 300mA or more may

## APPLICATIONS INFORMATION

**Table 2. Inductor Vendors**

| VENDOR           | URL               | PART SERIES  | INDUCTANCE RANGE ( $\mu\text{H}$ ) | SIZE (mm)                   |
|------------------|-------------------|--------------|------------------------------------|-----------------------------|
| Coilcraft        | www.coilcraft.com | DO1605       | 10 to 47                           | $1.8 \times 5.4 \times 4.2$ |
|                  |                   | ME3220       | 10 to 47                           | $2.0 \times 3.2 \times 2.5$ |
|                  |                   | D03314       | 10 to 47                           | $1.4 \times 3.3 \times 3.3$ |
| Sumida           | www.sumida.com    | CR32         | 10 to 47                           | $3.0 \times 3.8 \times 4.1$ |
|                  |                   | CDRH3D16/HP  | 10 to 33                           | $1.8 \times 4.0 \times 4.0$ |
|                  |                   | CDRH3D28     | 10 to 47                           | $3.0 \times 4.0 \times 4.0$ |
|                  |                   | CDRH2D18/HP  | 10 to 15                           | $2.0 \times 3.2 \times 3.2$ |
| Toko             | www.tokoam.com    | DB320C       | 10 to 27                           | $2.0 \times 3.8 \times 3.8$ |
|                  |                   | D52LC        | 10 to 47                           | $2.0 \times 5.0 \times 5.0$ |
| Würth Elektronik | www.we-online.com | WE-PD2 Typ S | 10 to 47                           | $3.2 \times 4.0 \times 4.5$ |
|                  |                   | WE-TPC Typ S | 10 to 22                           | $1.6 \times 3.8 \times 3.8$ |
| Coiltronics      | www.cooperet.com  | SD10         | 10 to 47                           | $1.0 \times 5.0 \times 5.0$ |
| Murata           | www.murata.com    | LQH43C       | 10 to 47                           | $2.6 \times 3.2 \times 4.5$ |
|                  |                   | LQH32C       | 10 to 15                           | $1.6 \times 2.5 \times 3.2$ |

be used. It is important to note that inductor saturation current is reduced at high temperatures—see inductor vendors for more information.

### Input Capacitor

Step-down regulators draw current from the input supply in pulses with very fast rise and fall times. The input capacitor is required to reduce the resulting voltage ripple at the  $V_{\text{IN}}$  pin of the LT3470 and to force this switching current into a tight local loop, minimizing EMI. The input capacitor must have low impedance at the switching frequency to do this effectively. A  $1\mu\text{F}$  to  $2.2\mu\text{F}$  ceramic capacitor satisfies these requirements.

If the input source impedance is high, a larger value capacitor may be required to keep input ripple low. In this case, an electrolytic of  $10\mu\text{F}$  or more in parallel with a  $1\mu\text{F}$  ceramic is a good combination. Be aware that the input capacitor is subject to large surge currents if the LT3470 circuit is connected to a low impedance supply, and that some electrolytic capacitors (in particular tantalum) must be specified for such use.

### Output Capacitor and Output Ripple

The output capacitor filters the inductor's ripple current and stores energy to satisfy the load current when the LT3470 is quiescent. In order to keep output voltage ripple low, the impedance of the capacitor must be low at the

LT3470's switching frequency. The capacitor's equivalent series resistance (ESR) determines this impedance. Choose one with low ESR intended for use in switching regulators. The contribution to ripple voltage due to the ESR is approximately  $I_{\text{LIM}} \cdot \text{ESR}$ . ESR should be less than  $\sim 150\text{m}\Omega$ . The value of the output capacitor must be large enough to accept the energy stored in the inductor without a large change in output voltage. Setting this voltage step equal to 1% of the output voltage, the output capacitor must be:

$$C_{\text{OUT}} > 50 \cdot L \cdot \left( \frac{I_{\text{LIM}}}{V_{\text{OUT}}} \right)^2$$

where  $I_{\text{LIM}}$  is the top current limit with  $V_{\text{FB}} = 0\text{V}$  (see Electrical Characteristics). For example, an LT3470 producing 3.3V with  $L = 33\mu\text{H}$  requires  $22\mu\text{F}$ . The calculated value can be relaxed if small circuit size is more important than low output ripple.

Sanyo's POSCAP series in B-case and provides very good performance in a small package for the LT3470. Similar performance in traditional tantalum capacitors requires a larger package (C-case). With a high quality capacitor filtering the ripple current from the inductor, the output voltage ripple is determined by the delay in the LT3470's feedback comparator. This ripple can be reduced further by adding a small (typically  $22\text{pF}$ ) phase lead capacitor between the output and the feedback pin.

## APPLICATIONS INFORMATION

### Ceramic Capacitors

Ceramic capacitors are small, robust and have very low ESR. However, ceramic capacitors can cause problems when used with the LT3470. Not all ceramic capacitors are suitable. X5R and X7R types are stable over temperature and applied voltage and give dependable service. Other types, including Y5V and Z5U have very large temperature and voltage coefficients of capacitance. In an application circuit they may have only a small fraction of their nominal capacitance resulting in much higher output voltage ripple than expected.

Ceramic capacitors are piezoelectric. The LT3470's switching frequency depends on the load current, and at light loads the LT3470 can excite the ceramic capacitor at audio frequencies, generating audible noise. Since the LT3470 operates at a lower current limit during Burst Mode operation, the noise is typically very quiet to a casual ear. If this audible noise is unacceptable, use a high performance electrolytic capacitor at the output. The input capacitor can be a parallel combination of a 2.2µF ceramic capacitor and a low cost electrolytic capacitor.

A final precaution regarding ceramic capacitors concerns the maximum input voltage rating of the LT3470. A ceramic input capacitor combined with trace or cable inductance forms a high quality (under damped) tank circuit. If the LT3470 circuit is plugged into a live supply, the input voltage can ring to twice its nominal value, possibly exceeding the LT3470's rating. This situation is easily avoided; see the Hot-Plugging Safely section.

### BOOST and BIAS Pin Considerations

Capacitor C3 and the internal boost Schottky diode (see Block Diagram) are used to generate a boost voltage that is higher than the input voltage. In most cases a 0.22µF capacitor will work well. Figure 2 shows two ways to arrange the boost circuit. The BOOST pin must be more than 2.5V above the SW pin for best efficiency. For outputs of 3.3V and above, the standard circuit (Figure 2a) is best. For outputs between 2.5V and 3V, use a 0.47µF. For lower output voltages the boost diode can be tied to the input

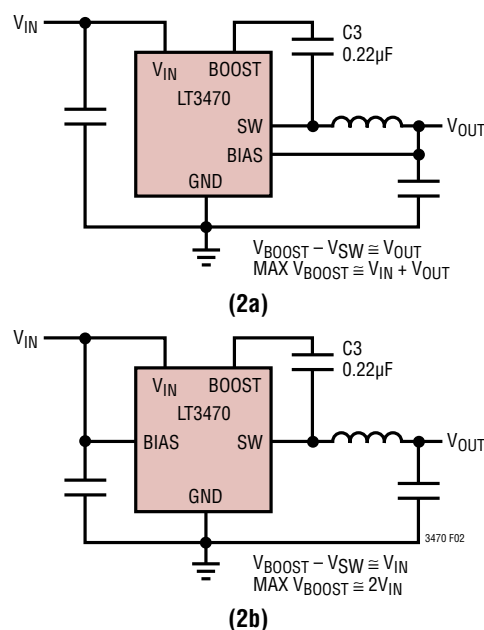

Figure 2. Two Circuits for Generating the Boost Voltage

Table 3. Capacitor Vendors

| VENDOR      | PHONE          | URL                 | PART SERIES                | COMMENTS   |
|-------------|----------------|---------------------|----------------------------|------------|
| Panasonic   | (714) 373-7366 | www.panasonic.com   | Ceramic, Polymer, Tantalum | EEF Series |
| Kemet       | (864) 963-6300 | www.kemet.com       | Ceramic, Tantalum          | T494, T495 |
| Sanyo       | (408) 749-9714 | www.sanyovideo.com  | Ceramic, Polymer, Tantalum | POSCAP     |
| Murata      | (404) 436-1300 | www.murata.com      | Ceramic                    |            |
| AVX         |                | www.avxcorp.com     | Ceramic, Tantalum          | TPS Series |
| Taiyo Yuden | (864) 963-6300 | www.taiyo-yuden.com | Ceramic                    |            |

## APPLICATIONS INFORMATION

(Figure 2b). The circuit in Figure 2a is more efficient because the BOOST pin current and BIAS pin quiescent current comes from a lower voltage source. You must also be sure that the maximum voltage ratings of the BOOST and BIAS pins are not exceeded.

The minimum operating voltage of an LT3470 application is limited by the undervoltage lockout (4V) and by the maximum duty cycle as outlined in a previous section. For proper start-up, the minimum input voltage is also limited by the boost circuit. If the input voltage is ramped slowly, or the LT3470 is turned on with its  $\overline{\text{SHDN}}$  pin when the output is already in regulation, then the boost capacitor may not be fully charged. The plots in Figure 3 show minimum

$V_{\text{IN}}$  to start and to run. At light loads, the inductor current becomes discontinuous and the effective duty cycle can be very high. This reduces the minimum input voltage to approximately 300mV above  $V_{\text{OUT}}$ . At higher load currents, the inductor current is continuous and the duty cycle is limited by the maximum duty cycle of the LT3470, requiring a higher input voltage to maintain regulation.

### Shorted Input Protection

If the inductor is chosen so that it won't saturate excessively at the top switch current limit maximum of 450mA, an LT3470 buck regulator will tolerate a shorted output even if  $V_{\text{IN}} = 40\text{V}$ . There is another situation to consider in systems where the output will be held high when the input to the LT3470 is absent. This may occur in battery charging applications or in battery backup systems where a battery or some other supply is diode OR-ed with the LT3470's output. If the  $V_{\text{IN}}$  pin is allowed to float and the  $\overline{\text{SHDN}}$  pin is held high (either by a logic signal or because it is tied to  $V_{\text{IN}}$ ), then the LT3470's internal circuitry will pull its quiescent current through its SW pin. This is fine if your system can tolerate a few mA in this state. If you ground the  $\overline{\text{SHDN}}$  pin, the SW pin current will drop to essentially zero. However, if the  $V_{\text{IN}}$  pin is grounded while the output is held high, then parasitic diodes inside the LT3470 can pull large currents from the output through the SW pin and the  $V_{\text{IN}}$  pin. Figure 4 shows a circuit that will run only when the input voltage is present and that protects against a shorted or reversed input.

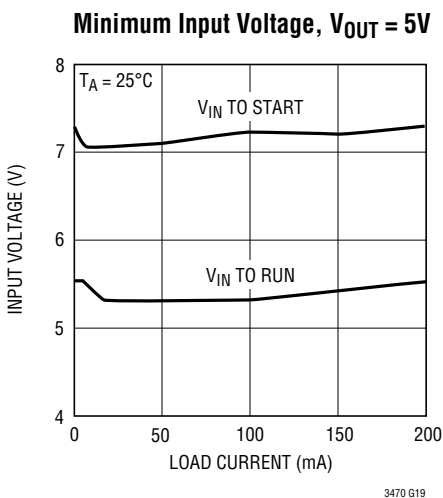
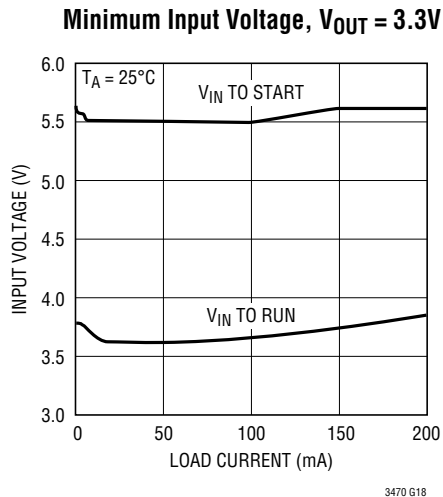

**Figure 3. The Minimum Input Voltage Depends on Output Voltage, Load Current and Boost Circuit**

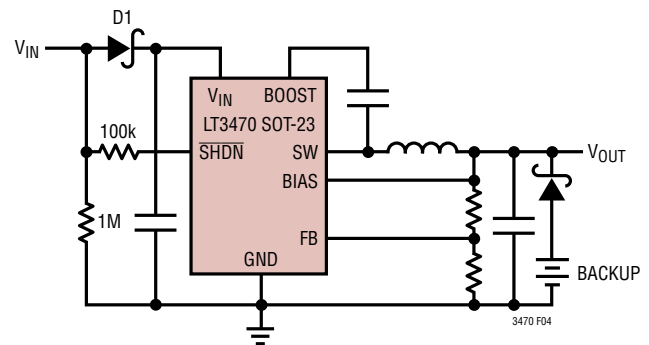

**Figure 4. Diode D1 Prevents a Shorted Input from Discharging a Backup Battery Tied to the Output; It Also Protects the Circuit from a Reversed Input. The LT3470 Runs Only When the Input Is Present Hot-Plugging Safely**

## APPLICATIONS INFORMATION

### PCB Layout

For proper operation and minimum EMI, care must be taken during printed circuit board layout. Note that large, switched currents flow in the power switch, the internal catch diode and the input capacitor. The loop formed by these components should be as small as possible. Furthermore, the system ground should be tied to the regulator ground in only one place; this prevents the switched current from injecting noise into the system ground. These components, along with the inductor and output capacitor, should be placed on the same side of the circuit board, and their connections should be made on that layer. Place a local, unbroken ground plane below these components, and tie this ground plane to system ground at one location,

ideally at the ground terminal of the output capacitor C2. Additionally, the SW and BOOST nodes should be kept as small as possible. Unshielded inductors can induce noise in the feedback path resulting in instability and increased output ripple. To avoid this problem, use vias to route the  $V_{OUT}$  trace under the ground plane to the feedback divider (as shown in Figure 5). Finally, keep the FB node as small as possible so that the ground pin and ground traces will shield it from the SW and BOOST nodes. Figure 5 shows component placement with trace, ground plane and via locations. Include vias near the GND pin, or pad, of the LT3470 to help remove heat from the LT3470 to the ground plane.

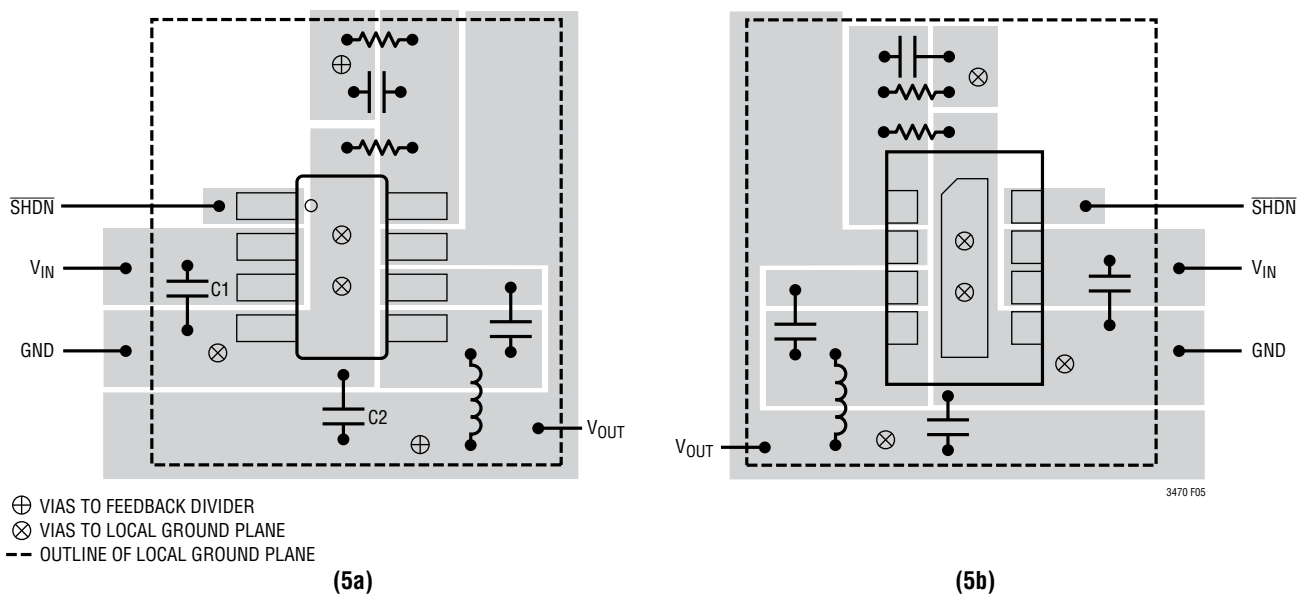

Figure 5. A Good PCB Layout Ensures Proper, Low EMI Operation

## APPLICATIONS INFORMATION

### Hot-Plugging Safely

The small size, robustness and low impedance of ceramic capacitors make them an attractive option for the input bypass capacitor of LT3470. However, these capacitors can cause problems if the LT3470 is plugged into a live supply (see Linear Technology Application Note 88 for a complete discussion). The low loss ceramic capacitor combined with stray inductance in series with the power source forms an under damped tank circuit, and the voltage at the  $V_{IN}$  pin of the LT3470 can ring to twice the nominal input voltage, possibly exceeding the LT3470's rating and damaging the part. If the input supply is poorly controlled or the user will be plugging the LT3470 into an energized supply, the input network should be designed to prevent this overshoot. Figure 6 shows the waveforms that result when an LT3470 circuit is connected to a 24V supply through six feet of 24-gauge twisted pair. The first plot is the response with a 2.2 $\mu$ F ceramic capacitor at the input. The input voltage rings as high as 35V and the input current peaks at 20A. One method of damping the tank circuit is to add another capacitor with a series resistor to the circuit. In Figure 6b an aluminum electrolytic capacitor has been added. This capacitor's high equivalent series resistance damps the circuit and eliminates the voltage overshoot. The extra capacitor improves low frequency ripple filtering and can slightly improve the efficiency of the circuit, though it is likely to be the largest component in the circuit. An alternative solution is shown in Figure 6c. A 1 $\Omega$  resistor is added in series with the input to eliminate the voltage overshoot

(it also reduces the peak input current). A 0.1 $\mu$ F capacitor improves high frequency filtering. This solution is smaller and less expensive than the electrolytic capacitor. For high input voltages its impact on efficiency is minor, reducing efficiency less than one half percent for a 5V output at full load operating from 24V.

### High Temperature Considerations

The die junction temperature of the LT3470 must be lower than the maximum rating of 125°C (150°C for the H-grade). This is generally not a concern unless the ambient temperature is above 85°C. For higher temperatures, care should be taken in the layout of the circuit to ensure good heat sinking of the LT3470. The maximum load current should be derated as the ambient temperature approaches the maximum junction rating. The die temperature is calculated by multiplying the LT3470 power dissipation by the thermal resistance from junction to ambient. Power dissipation within the LT3470 can be estimated by calculating the total power loss from an efficiency measurement. Thermal resistance depends on the layout of the circuit board and choice of package. The DD package with the exposed pad has a thermal resistance of approximately 80°C/W while the ThinSOT is approximately 150°C/W. Finally, be aware that at high ambient temperatures the internal Schottky diode will have significant leakage current (see Typical Performance Characteristics) increasing the quiescent current of the LT3470 converter.

APPLICATIONS INFORMATION

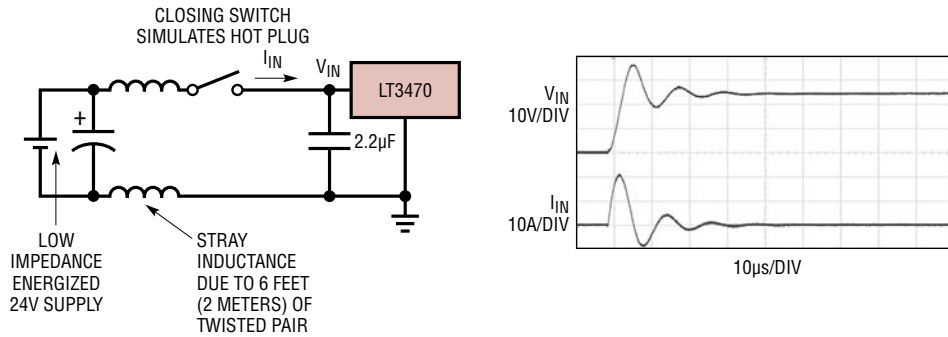

(6a)

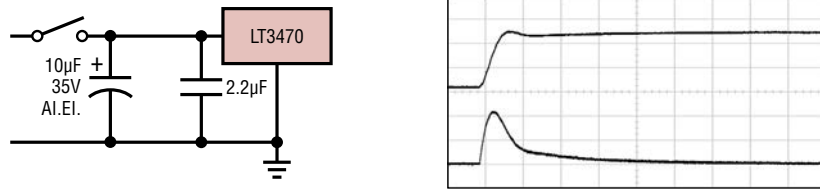

(6b)

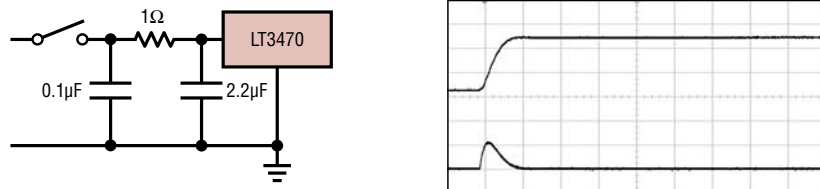

(6c)

3470 F06

Figure 6. A Well Chosen Input Network Prevents Input Voltage Overshoot and Ensures Reliable Operation When the LT3470 Is Connected to a Live Supply

## TYPICAL APPLICATIONS

### 3.3V Step-Down Converter

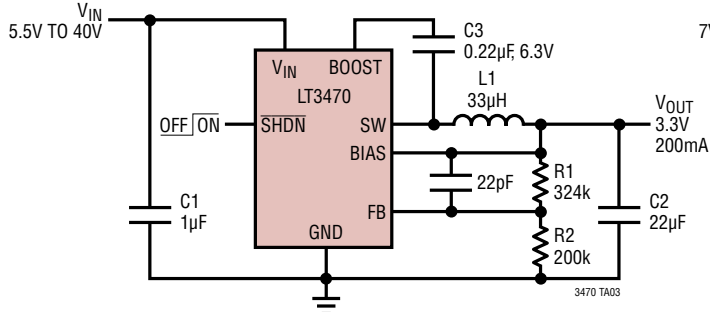

C1: TDK C3216JB1H105M  
C2: CE JMK316 BJ226ML-T  
L1: TOKO A993AS-270M=P3

### 5V Step-Down Converter

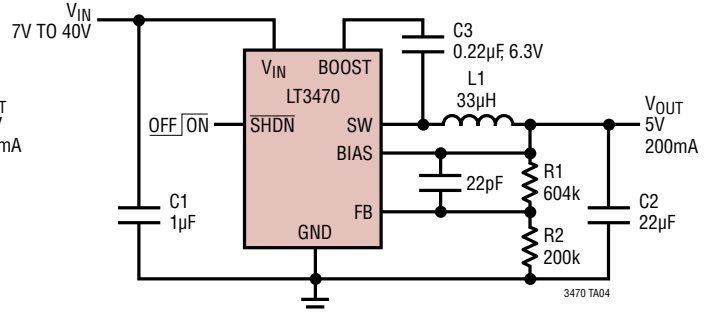

C1: TDK C3216JB1H105M  
C2: CE JMK316 BJ226ML-T  
L1: TOKO A914BYW-330M=P3

### 2.5V Step-Down Converter

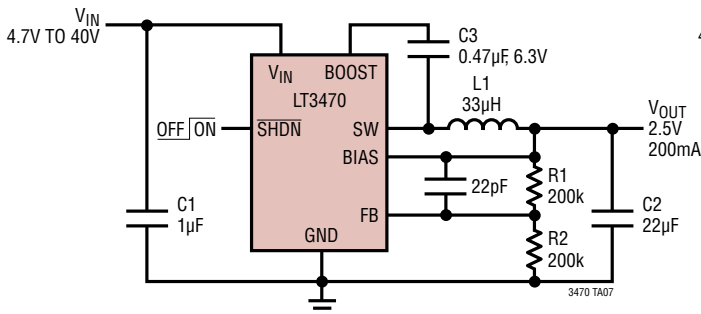

C1: TDK C3216JB1H105M  
C2: TDK C2012JB0J226M  
L1: SUMIDA CDRH3D28

### 1.8V Step-Down Converter

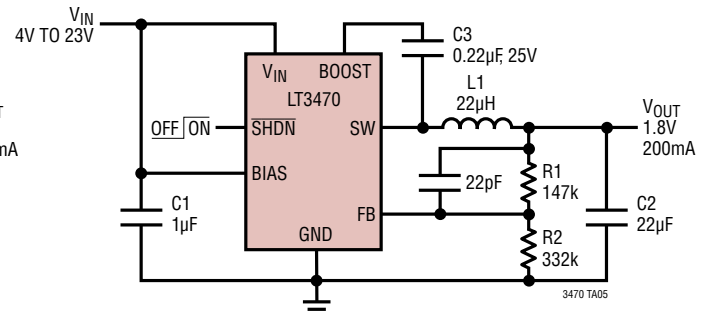

C1: TDK C3216JB1H105M  
C2: TDK C2012JB0J226M  
L1: MURATA LQH32CN150K53

### 12V Step-Down Converter

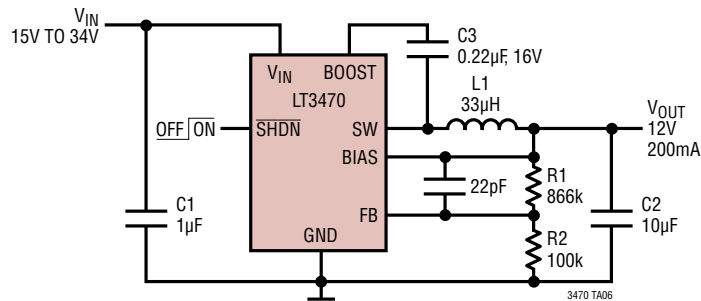

C1: TDK C3216JB1H105M  
C2: TDK C3216JB1C106M  
L1: MURATA LQH32CN150K53

**PACKAGE DESCRIPTION**

**TS8 Package**  
**8-Lead Plastic TSOT-23**  
 (Reference LTC DWG # 05-08-1637 Rev A)

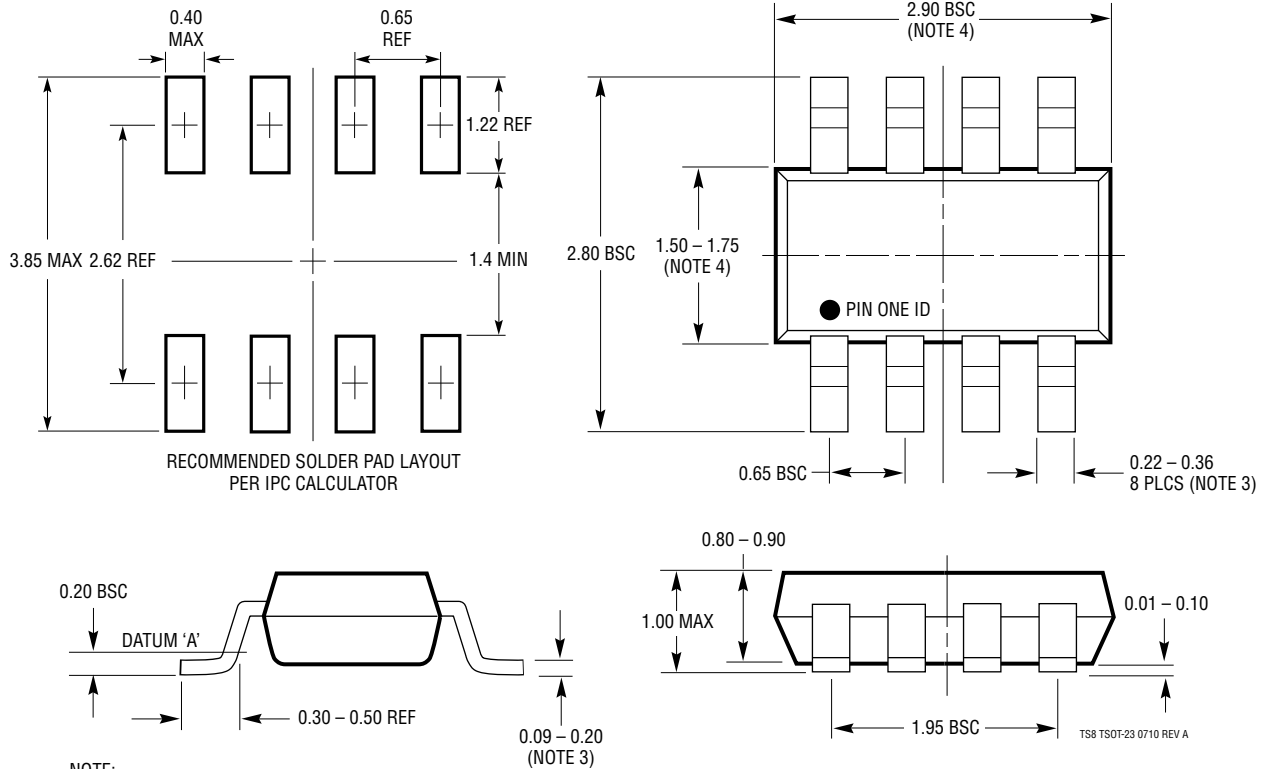

- NOTE:
1. DIMENSIONS ARE IN MILLIMETERS
  2. DRAWING NOT TO SCALE
  3. DIMENSIONS ARE INCLUSIVE OF PLATING
  4. DIMENSIONS ARE EXCLUSIVE OF MOLD FLASH AND METAL BURR
  5. MOLD FLASH SHALL NOT EXCEED 0.254mm
  6. JEDEC PACKAGE REFERENCE IS MO-193



**REVISION HISTORY** (Revision history begins at Rev D)

| REV | DATE  | DESCRIPTION   | PAGE NUMBER |
|-----|-------|---|-------------|
| D   | 09/11 | Corrected lead-based tape and reel part numbers in the Order Information section. | 2           |
| E   | 04/20 | Added AEC-Q100 Qualified.   | 1           |
|     |       | Added #W options for automotive under Order Information.                          | 3           |
|     |       | Updated Inductor vendors table.   | 10          |

## RELATED PARTS

| PART NUMBER      | DESCRIPTION  | COMMENTS  |
|------------------|--|---|
| LT1616           | 25V, 500mA ( $I_{OUT}$ ), 1.4MHz, High Efficiency Step-Down DC/DC Converter  | $V_{IN} = 3.6V$ to 25V, $V_{OUT} = 1.25V$ , $I_Q = 1.9mA$ , $I_{SD} < 1\mu A$ , ThinSOT Package       |
| LT1676           | 60V, 440mA ( $I_{OUT}$ ), 100kHz, High Efficiency Step-Down DC/DC Converter  | $V_{IN} = 7.4V$ to 60V, $V_{OUT} = 1.24V$ , $I_Q = 3.2mA$ , $I_{SD} = 2.5\mu A$ , S8 Package          |
| LT1765           | 25V, 2.75A ( $I_{OUT}$ ), 1.25MHz, High Efficiency Step-Down DC/DC Converter | $V_{IN} = 3V$ to 25V, $V_{OUT} = 1.2V$ , $I_Q = 1mA$ , $I_{SD} = 15\mu A$ , S8, TSSOP16E Packages     |
| LT1766           | 60V, 1.2A ( $I_{OUT}$ ), 200kHz, High Efficiency Step-Down DC/DC Converter   | $V_{IN} = 5.5V$ to 60V, $V_{OUT} = 1.2V$ , $I_Q = 2.5mA$ , $I_{SD} = 25\mu A$ , TSSOP16/E Package     |
| LT1767           | 25V, 1.2A ( $I_{OUT}$ ), 1.25MHz, High Efficiency Step-Down DC/DC Converter  | $V_{IN} = 3V$ to 25V; $V_{OUT} = 1.2V$ , $I_Q = 1mA$ , $I_{SD} = 6\mu A$ , MS8/E Packages             |
| LT1776           | 40V, 550mA ( $I_{OUT}$ ), 200kHz, High Efficiency Step-Down DC/DC Converter  | $V_{IN} = 7.4V$ to 40V; $V_{OUT} = 1.24V$ , $I_Q = 3.2mA$ , $I_{SD} = 30\mu A$ , N8, S8 Packages      |
| LTC®1877         | 600mA ( $I_{OUT}$ ), 550kHz, Synchronous Step-Down DC/DC Converter           | $V_{IN} = 2.7V$ to 10V; $V_{OUT} = 0.8V$ , $I_Q = 10\mu A$ , $I_{SD} \leq 1\mu A$ , MS8 Package       |
| LTC1879          | 1.2A ( $I_{OUT}$ ), 550kHz, Synchronous Step-Down DC/DC Converter            | $V_{IN} = 2.7V$ to 10V; $V_{OUT} = 0.8V$ , $I_Q = 15\mu A$ , $I_{SD} \leq 1\mu A$ , TSSOP16 Package   |
| LT1933           | 36V, 600mA, 500kHz, High Efficiency Step-Down DC/DC Converter                | $V_{IN} = 3.6V$ to 36V; $V_{OUT} = 1.25V$ , $I_Q = 2.5\mu A$ , $I_{SD} \leq 1\mu A$ , ??? Package     |
| LT1934           | 34V, 250mA ( $I_{OUT}$ ), Micropower, Step-Down DC/DC Converter              | $V_{IN} = 3.2V$ to 34V; $V_{OUT} = 1.25V$ , $I_Q = 12\mu A$ , $I_{SD} \leq 1\mu A$ , ??? Package      |
| LT1956           | 60V, 1.2A ( $I_{OUT}$ ), 500kHz, High Efficiency Step-Down DC/DC Converter   | $V_{IN} = 5.5V$ to 60V, $V_{OUT} = 1.2V$ , $I_Q = 2.5mA$ , $I_{SD} = 25\mu A$ , TSSOP16/E Package     |
| LTC3405/LTC3405A | 300mA ( $I_{OUT}$ ), 1.5MHz, Synchronous Step-Down DC/DC Converter           | $V_{IN} = 2.7V$ to 6V, $V_{OUT} = 0.8V$ , $I_Q = 20\mu A$ , $I_{SD} \leq 1\mu A$ , ThinSOT Package    |
| LTC3406/LTC3406B | 600mA ( $I_{OUT}$ ), 1.5MHz, Synchronous Step-Down DC/DC Converter           | $V_{IN} = 2.5V$ to 5.5V, $V_{OUT} = 0.6V$ , $I_Q = 20\mu A$ , $I_{SD} \leq 1\mu A$ , ThinSOT Package  |
| LTC3411          | 1.25A ( $I_{OUT}$ ), 4MHz, Synchronous Step-Down DC/DC Converter             | $V_{IN} = 2.5V$ to 5.5V, $V_{OUT} = 0.8V$ , $I_Q = 60\mu A$ , $I_{SD} \leq 1\mu A$ , MS Package       |
| LTC3412          | 2.5A ( $I_{OUT}$ ), 4MHz, Synchronous Step-Down DC/DC Converter              | $V_{IN} = 2.5V$ to 5.5V, $V_{OUT} = 0.8V$ , $I_Q = 60\mu A$ , $I_{SD} \leq 1\mu A$ , TSSOP16E Package |
| LTC3430          | 60V, 2.75A ( $I_{OUT}$ ), 200kHz, High Efficiency Step-Down DC/DC Converter  | $V_{IN} = 5.5V$ to 60V, $V_{OUT} = 1.2V$ , $I_Q = 2.5mA$ , $I_{SD} = 30\mu A$ , TSSOP16E Package      |

## Looking for pricing, stock, or lifecycle information?

Click below to explore more details on WIN SOURCE:

 [View LT3470HTS8#TRMPBF on WIN SOURCE](#)

 [Analog Devices Inc. Information](#)

## Optimize Your Supply Chain with WIN SOURCE Solutions

-  Global Sourcing Solution
-  Obsolete Management
-  Cost Control Management
-  Shortage Management
-  Alternative Solution
-  Excess Inventory Management