

Analog Multiplexer/ Demultiplexer

High-Performance Silicon-Gate CMOS

MC74LVX4051, MC74LVX4052, MC74LVX4053, MC74LVXT4051, MC74LVXT4052, MC74LVXT4053

These devices utilize silicon-gate CMOS technology to achieve fast propagation delays, low ON resistances, and low leakage currents. This analog multiplexer/demultiplexer controls analog voltages that may vary across the complete power supply range (from V_{CC} to V_{EE}).

The devices are similar in pinout to the LVX805n, the HC405nA, and the metal-gate MC1405nB. The Channel-Select inputs determine which one of the Analog Inputs/Outputs is to be connected, by means of an analog switch, to the Common Output/Input. When the Enable pin is HIGH, all analog switches are turned off.

The Channel-Select and Enable inputs are compatible with standard CMOS outputs. These inputs are overvoltage tolerant (OVT) for level translation from 6.0 V down to 3.0 V.

This device has been designed so the ON resistance (R_{ON}) is more linear over input voltage than the R_{ON} of metal-gate CMOS analog switches and High-Speed CMOS analog switches.

Features

- Fast Switching and Propagation Speeds
- Low Crosstalk Between Switches
- Analog Power Supply Range ($V_{CC} - V_{EE}$) = -3.0 V to +3.0 V
- Digital (Control) Power Supply Range ($V_{CC} - GND$) = 2.5 to 6.0 V
- Improved Linearity and Lower ON Resistance Than Metal-Gate, HSL, or VHC Counterparts
- Low Noise
- Designed to Operate on a Single Supply with $V_{EE} = GND$, or Using Split Supplies up to ± 3.0 V
- Break-Before-Make Circuitry
- -Q Suffix for Automotive and Other Applications Requiring Unique Site and Control Change Requirements; AEC-Q100 Qualified and PPAP Capable
- These Devices are Pb-Free, Halogen Free and are RoHS Compliant



QFN16
MN SUFFIX
CASE 485AW

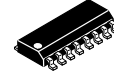

SOIC-16
D SUFFIX
CASE 751B

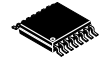

TSSOP-16
DT SUFFIX
CASE 948F

MARKING DIAGRAMS

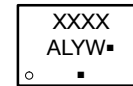

QFN16

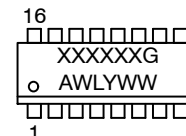

SOIC-16

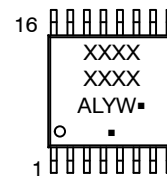

TSSOP-16

- XXXXXX = Specific Device Code
- A = Assembly Location
- WL, L = Wafer Lot
- Y = Year
- WW, W = Work Week
- G or ■ = Pb-Free Package

(Note: Microdot may be in either location)

ORDERING INFORMATION

See detailed ordering and shipping information in the package dimensions section on page 16 of this data sheet.

MC74LVX4051, MC74LVX4052, MC74LVX4053, MC74LVXT4051, MC74LVXT4052, MC74LVXT4053

FUNCTION TABLE - 4051

Control Inputs				ON Channels
Enable	Select			
	C	B	A	
L	L	L	L	X0
L	L	L	H	X1
L	L	H	L	X2
L	L	H	H	X3
L	H	L	L	X4
L	H	L	H	X5
L	H	H	L	X6
L	H	H	H	X7
H	X	X	X	NONE

X = Don't Care

**LOGIC DIAGRAM
4051
Single-Pole, 8-Position Plus Common Off**

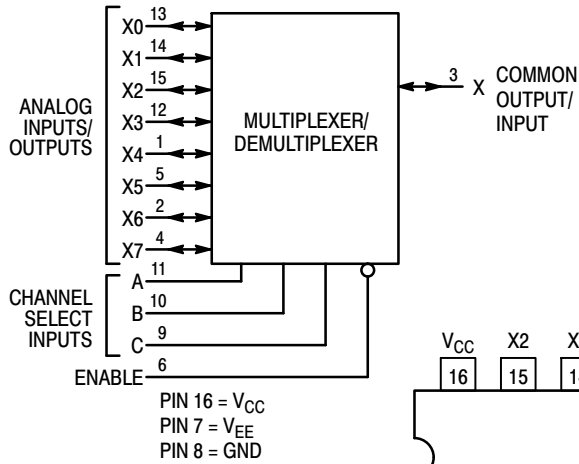

Pinouts: 4051 (Top View)

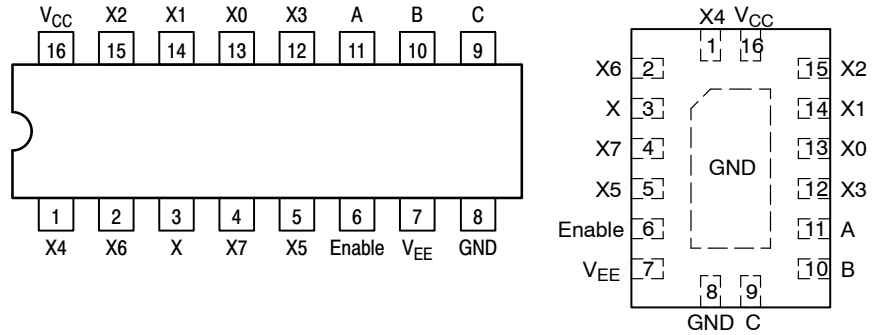

FUNCTION TABLE - 4052

Control Inputs			ON Channels	
Enable	Select		Y0	X0
	B	A		
L	L	L	Y1	X1
L	L	H	Y2	X2
L	H	L	Y3	X3
L	H	H		
H	X	X	NONE	

X = Don't Care

**LOGIC DIAGRAM
4052
Double-Pole, 4-Position Plus Common Off**

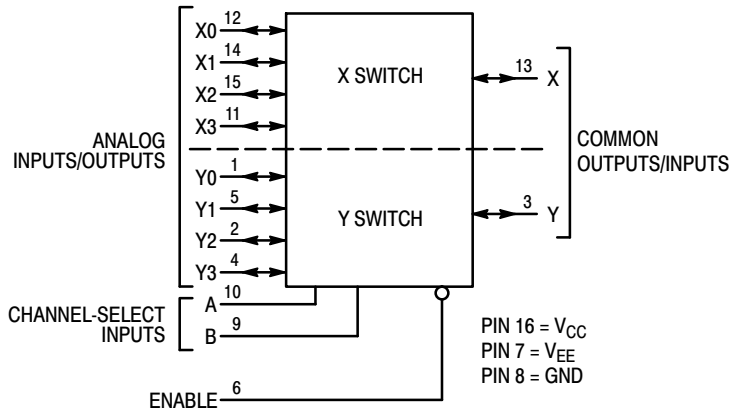

Pinout: 4052 (Top View)

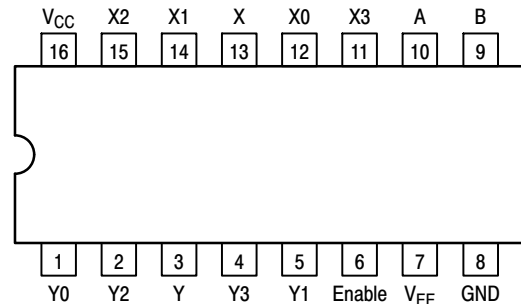

MC74LVX4051, MC74LVX4052, MC74LVX4053, MC74LVXT4051, MC74LVXT4052, MC74LVXT4053

FUNCTION TABLE – 4053

**LOGIC DIAGRAM
4053
Triple Single-Pole, Double-Position Plus Common Off**

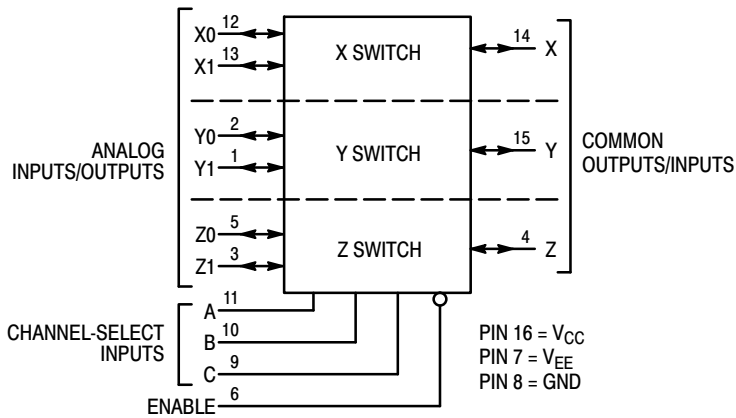

NOTE: This device allows independent control of each switch. Channel-Select Input A controls the X-Switch, Input B controls the Y-Switch and Input C controls the Z-Switch

Control Inputs		ON Channels				
Enable	Select					
	C	B	A	Z0	Y0	X0
L	L	L	L	Z0	Y0	X0
L	L	L	H	Z0	Y0	X1
L	L	H	L	Z0	Y1	X0
L	L	H	H	Z0	Y1	X1
L	H	L	L	Z1	Y0	X0
L	H	L	H	Z1	Y0	X1
L	H	H	L	Z1	Y1	X0
L	H	H	H	Z1	Y1	X1
H	X	X	X	NONE		

X = Don't Care

Pinout: 4053 (Top View)

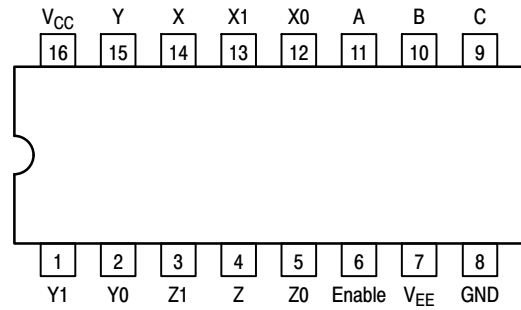

MC74LVX4051, MC74LVX4052, MC74LVX4053, MC74LVXT4051, MC74LVXT4052, MC74LVXT4053

MAXIMUM RATINGS (Voltages referenced to GND unless otherwise specified)

Symbol	Parameter	Value	Unit	
V_{CC}	Positive DC Supply Voltage	-0.5 to +6.5	V	
$V_{CC} - V_{EE}$	DC Supply Voltage	-0.5 to +6.5	V	
V_{IS}	Analog Input Voltage	$V_{EE}-0.5$ to $V_{CC}+0.5$	V	
V_{IN}	Digital Input Voltage (Referenced to V_{EE})	-0.5 to +6.5	V	
I	DC Current, into or out of any pin	± 50	mA	
T_{STG}	Storage Temperature Range	-65 to +150	°C	
T_L	Lead Temperature, 1 mm from Case for 10 secs	+260	°C	
T_J	Junction Temperature Under Bias	+150	°C	
θ_{JA}	Thermal Resistance (Note 1)	SOIC-16 QFN16 TSSOP-16	126 118 159	°C/W
P_D	Power Dissipation in Still Air at 25°C	SOIC-16 QFN16 TSSOP-16	995 1062 787	mW
MSL	Moisture Sensitivity	Level 1	-	
F_R	Flammability Rating Oxygen Index: 30% to 35%	UL 94 V-0 @ 0.125 in	-	
V_{ESD}	ESD Withstand Voltage (Note 2)	Human Body Model Charged Device Model	> 2000 > 1000	V

Stresses exceeding those listed in the Maximum Ratings table may damage the device. If any of these limits are exceeded, device functionality should not be assumed, damage may occur and reliability may be affected.

1. Measured with minimum pad spacing on an FR4 board, using 76 mm-by-114 mm, 2-ounce copper trace no air flow per JESD51-7.
2. HBM tested to EIA / JESD22-A114-A. CDM tested to JESD22-C101-A. JEDEC recommends that ESD qualification to EIA/JESD22-A115A (Machine Model) be discontinued.

RECOMMENDED OPERATING CONDITIONS (Voltages referenced to GND unless otherwise specified)

Symbol	Parameter	Min	Max	Unit
V_{CC}	Positive DC Supply Voltage	2.5	6.0	V
V_{EE}	Negative DC Supply Voltage	-3.5	GND	V
$V_{CC} - V_{EE}$	DC Supply Voltage	2.5	6.0	V
V_{IS}	Analog Input Voltage	V_{EE}	V_{CC}	V
V_{IN}	Digital Input Voltage (Note 3) (Referenced to V_{EE})	0	6.0	V
T_A	Operating Temperature Range	-55	+125	°C
t_r, t_f	Input Transition Rise or Fall Time (Channel Select or Enable Inputs)	$V_{CC} = 3.0 V \pm 0.3 V$ $V_{CC} = 5.0 V \pm 0.5 V$	0 100	ns/V

Functional operation above the stresses listed in the Recommended Operating Ranges is not implied. Extended exposure to stresses beyond the Recommended Operating Ranges limits may affect device reliability.

3. Unused inputs must always be tied to an appropriate logic voltage level (e.g., either GND or VCC). Unused outputs must be left open.

MC74LVX4051, MC74LVX4052, MC74LVX4053, MC74LVXT4051, MC74LVXT4052, MC74LVXT4053

DC CHARACTERISTICS – Digital Section (Voltages Referenced to GND)

Symbol	Parameter	Condition	V _{CC} V	Guaranteed Limit			Unit
				-55 to 25°C	≤85°C	≤125°C	
MC74LVX							
V _{IH}	Minimum High-Level Input Voltage, Channel-Select or Enable Inputs		2.5	1.90	1.90	1.90	V
			3.0	2.10	2.10	2.10	
			4.5	3.15	3.15	3.15	
			6.0	4.2	4.2	4.2	
V _{IL}	Maximum Low-Level Input Voltage, Channel-Select or Enable Inputs		2.5	0.6	0.6	0.6	V
			3.0	0.9	0.9	0.9	
			4.5	1.35	1.35	1.35	
			6.0	1.8	1.8	1.8	
I _{IN}	Maximum Input Leakage Current, Channel-Select or Enable Inputs	V _{IN} = 6.0 or GND	0 V to 6.0 V	±0.1	±1.0	±1.0	μA
I _{CC}	Maximum Quiescent Supply Current (per Package)	Channel Select, Enable and V _{IS} = V _{CC} or GND	6.0	4.0	40	80	μA

MC74LVXT

V _{IH}	Minimum High-Level Input Voltage, Channel-Select or Enable Inputs		3.0	2.0	2.0	2.0	V
			4.5	2.0	3.15	3.15	
			5.5	2.0	4.2	4.2	
V _{IL}	Maximum Low-Level Input Voltage, Channel-Select or Enable Inputs		3.0	0.9	0.9	0.9	V
			4.5	1.35	1.35	1.35	
			6.0	1.8	1.8	1.8	
I _{IN}	Maximum Input Leakage Current, Channel-Select or Enable Inputs	V _{IN} = 6.0 or GND	0 V to 6.0 V	±0.1	±1.0	±1.0	μA
I _{CC}	Maximum Quiescent Supply Current (per Package)	Channel Select, Enable and V _{IS} = V _{CC} or GND	6.0	4.0	40	80	μA

DC ELECTRICAL CHARACTERISTICS – Analog Section

Symbol	Parameter	Test Conditions	V _{CC} V	V _{EE} V	Guaranteed Limit			Unit
					-55 to 25°C	≤85°C	≤125°C	
R _{ON}	Maximum "ON" Resistance	V _{IN} = V _{IL} or V _{IH} V _{IS} = ½ (V _{CC} + V _{EE}) I _S = 2.0 mA (Figure 1)	3.0	0	86	108	120	Ω
			4.5	0	37	46	55	
			3.0	-3.0	26	33	37	
ΔR _{ON}	Maximum Difference in "ON" Resistance Between Any Two Channels in the Same Package	V _{IN} = V _{IL} or V _{IH} V _{IS} = ½ (V _{CC} + V _{EE}) I _S = 2.0 mA	3.0	0	15	20	20	Ω
			4.5	0	13	18	18	
			3.0	-3.0	10	15	15	
I _{off}	Maximum Off-Channel Leakage Current, Any One Channel	V _{in} = V _{IL} or V _{IH} ; V _{IO} = V _{CC} or V _{EE} ; Switch Off (Figure 2)	5.5 +3.0	0 -3.0	0.1 0.1	0.5 0.5	1.0 1.0	μA
	Maximum Off-Channel Leakage Current, Common Channel	V _{in} = V _{IL} or V _{IH} ; V _{IO} = V _{CC} or V _{EE} ; Switch Off (Figure 3)	5.5 +3.0	0 -3.0	0.2 0.2	2.0 2.0	4.0 4.0	
I _{on}	Maximum On-Channel Leakage Current, Channel-to-Channel	V _{in} = V _{IL} or V _{IH} ; Switch-to-Switch = V _{CC} or V _{EE} ; (Figure 4)	5.5 +3.0	0 -3.0	0.2 0.2	2.0 2.0	4.0 4.0	μA

AC CHARACTERISTICS (Input t_r = t_f = 3 ns)

Symbol	Parameter	Test Conditions	V _{CC} V	V _{EE} V	Guaranteed Limit				Unit
					-55 to 25°C		≤85°C	≤125°C	
					Min	Typ*			
t _{BBM}	Minimum Break-Before-Make Time	V _{IN} = V _{IL} or V _{IH} V _{IS} = V _{CC} R _L = 300 Ω, C _L = 35 pF (Figures 9 and 10)	3.0	0.0	1.0	6.5	-	-	ns
			4.5	0.0	1.0	5.0	-	-	
			3.0	-3.0	1.0	3.5	-	-	

*Typical Characteristics are at 25°C.

**MC74LVX4051, MC74LVX4052, MC74LVX4053, MC74LVXT4051, MC74LVXT4052,
MC74LVXT4053**

AC CHARACTERISTICS ($C_L = 50$ pF, Input $t_r = t_f = 3$ ns)

Symbol	Parameter	V _{CC} V	V _{EE} V	Guaranteed Limit						Unit	
				-55 to 25°C			≤85°C		≤125°C		
				Min	Typ	Max	Min	Max	Min		Max
t _{PLH} , t _{PHL}	Maximum Propagation Delay, Channel-Select to Analog Output (Figures 11 and 12)	2.5	0			40		45		50	ns
		3.0	0			28		30		35	
		4.5	0			23		25		30	
		3.0	-3.0			23		25		28	
t _{PLZ} , t _{PHZ}	Maximum Propagation Delay, Enable to Analog Output (Figures 13 and 14)	2.5	0			40		45		50	ns
		3.0	0			28		30		35	
		4.5	0			23		25		30	
		3.0	-3.0			23		25		28	
t _{PZL} , t _{PZH}	Maximum Propagation Delay, Enable to Analog Output (Figures 13 and 14)	2.5	0			40		45		50	ns
		3.0	0			28		30		35	
		4.5	0			23		25		30	
		3.0	-3.0			23		25		28	
C _{PD}	Power Dissipation Capacitance (Figure 15) (Note 4)	Typical @ 25°C, V _{CC} = 5.0 V, V _{EE} = 0 V						pF			
		45									
C _{IN}	Maximum Input Capacitance, Channel-Select or Enable Inputs	10						pF			
C _{I/O}	Maximum Capacitance (All Switches Off)					Analog I/O		10	pF		
						Common O/I		10			
						Feedthrough		1.0			

4. Used to determine the no-load dynamic power consumption: $P_D = C_{PD} V_{CC}^2 f + I_{CC} V_{CC}$.

ADDITIONAL APPLICATION CHARACTERISTICS (GND = 0 V)

Symbol	Parameter	Condition	V _{CC} V	V _{EE} V	Typ	Unit
					25°C	
BW	Maximum On-Channel Bandwidth or Minimum Frequency Response	(Figure 5)	3.0	0.0	80	MHz
			4.5	0.0	80	
			6.0	0.0	80	
			3.0	-3.0	80	
V _{ISO}	Off-Channel Feedthrough Isolation	(Figure 6)	3.0	0.0	-70	dB
			4.5	0.0	-70	
			6.0	0.0	-70	
			3.0	-3.0	-70	
V _{ONL}	Maximum Feedthrough On Loss	(Figure 7)	3.0	0.0	-2	dB
			4.5	0.0	-2	
			6.0	0.0	-2	
			3.0	-3.0	-2	
Q	Charge Injection	(Figure 8)	5.0	0.0	9.0	pC
			3.0	-3.0	12	
THD	Total Harmonic Distortion + Noise	f _{IS} = 1 MHz, R _L = 10 KΩ, C _L = 50 pF, V _{IS} = 5.0 V _{PP} sine wave + DC Bias V _{IS} = 6.0 V _{PP} sine wave + DC Bias (Figure 16)	6.0	0.0	0.10	%
			3.0	-3.0	0.05	

MC74LVX4051, MC74LVX4052, MC74LVX4053, MC74LVXT4051, MC74LVXT4052,
MC74LVXT4053

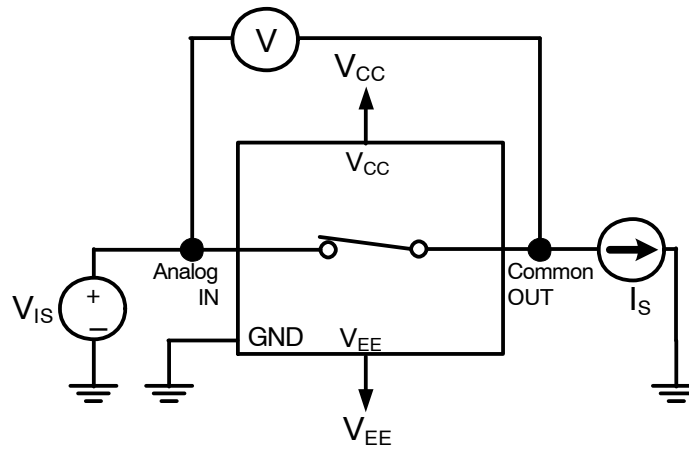

Figure 1. On Resistance

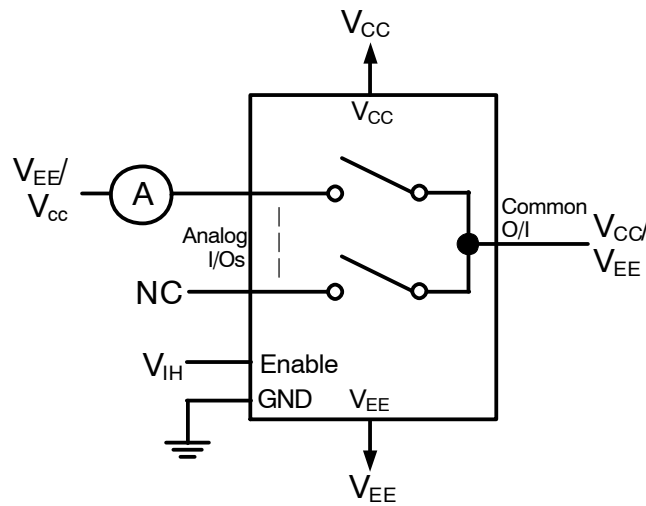

Figure 2. Off Channel Leakage, Any One Channel

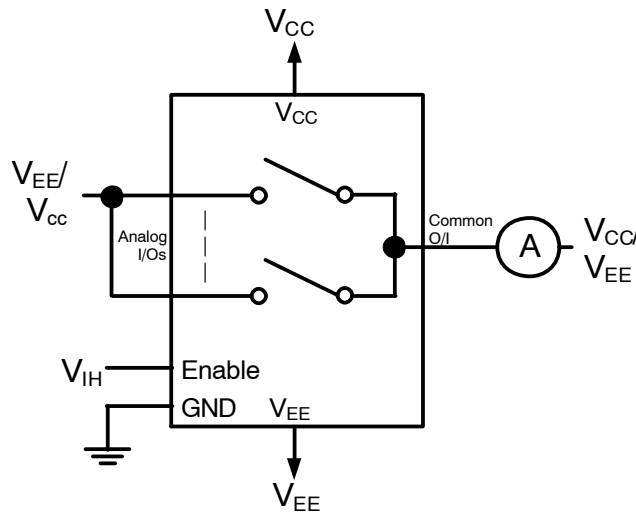

Figure 3. Off Channel Leakage, Common Channel

MC74LVX4051, MC74LVX4052, MC74LVX4053, MC74LVXT4051, MC74LVXT4052, MC74LVXT4053

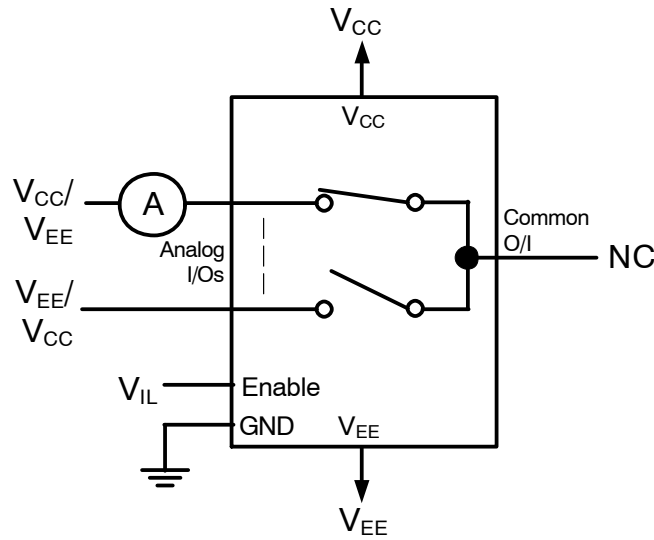
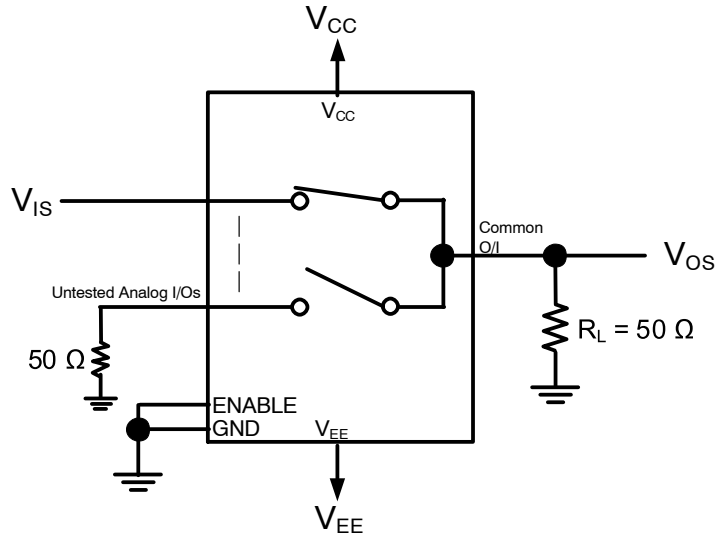

Figure 4. On Channel Leakage



- DC Bias = $(V_{CC} + V_{EE})/2$
 V_{IS} = sine wave + DC Bias
 (1) Adjust V_{IS} Amplitude for 0 dBm at V_{OS}
 (2) Increase f_{IS} until V_{OS} at -3 dB of step 1

Figure 5. Bandwidth

MC74LVX4051, MC74LVX4052, MC74LVX4053, MC74LVXT4051, MC74LVXT4052, MC74LVXT4053

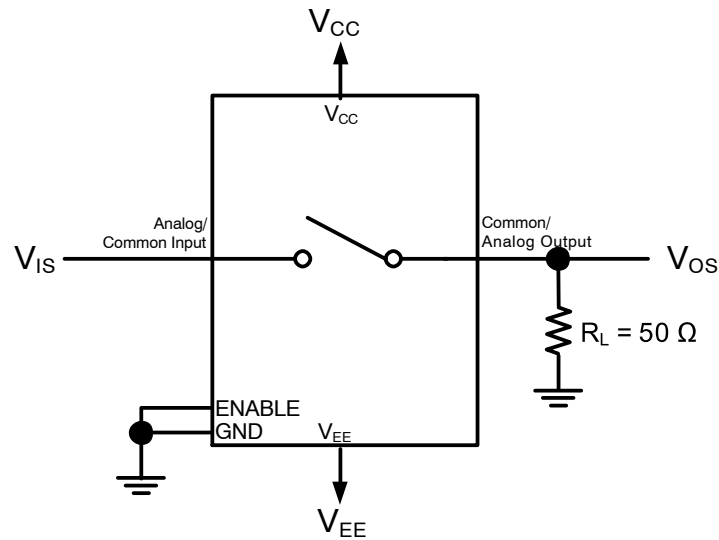

$f = 1 \text{ MHz}$
 $\text{DC Bias} = (V_{CC} + V_{EE})/2$
 $V_{IS} = \text{sine wave} + \text{DC Bias}$
 (1) Adjust V_{IS} Amplitude to 10 dBm
 (2) $V_{ISO}(\text{dB}) = 20 \log (V_{OS}/V_{IS})$

Figure 6. Common/Off Channel Feedthrough Isolation

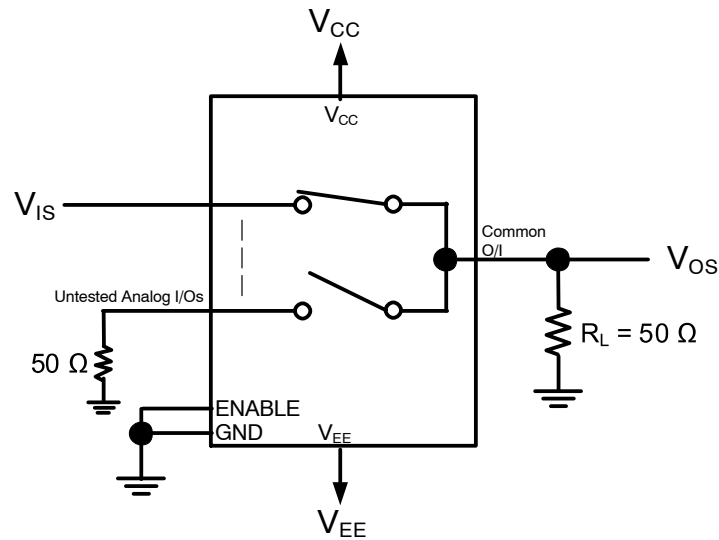

$f_{IS} = 1 \text{ kHz}$
 $\text{DC Bias} = (V_{CC} + V_{EE})/2$
 $V_{IS} = \text{sine wave} + \text{DC Bias}$
 (1) Adjust V_{IS} Amplitude to 0 dBm
 (2) $V_{ONL}(\text{dB}) = 20 \log (V_{OS}/V_{IS})$

Figure 7. On Channel Feedthrough On Loss

**MC74LVX4051, MC74LVX4052, MC74LVX4053, MC74LVXT4051, MC74LVXT4052,
MC74LVXT4053**

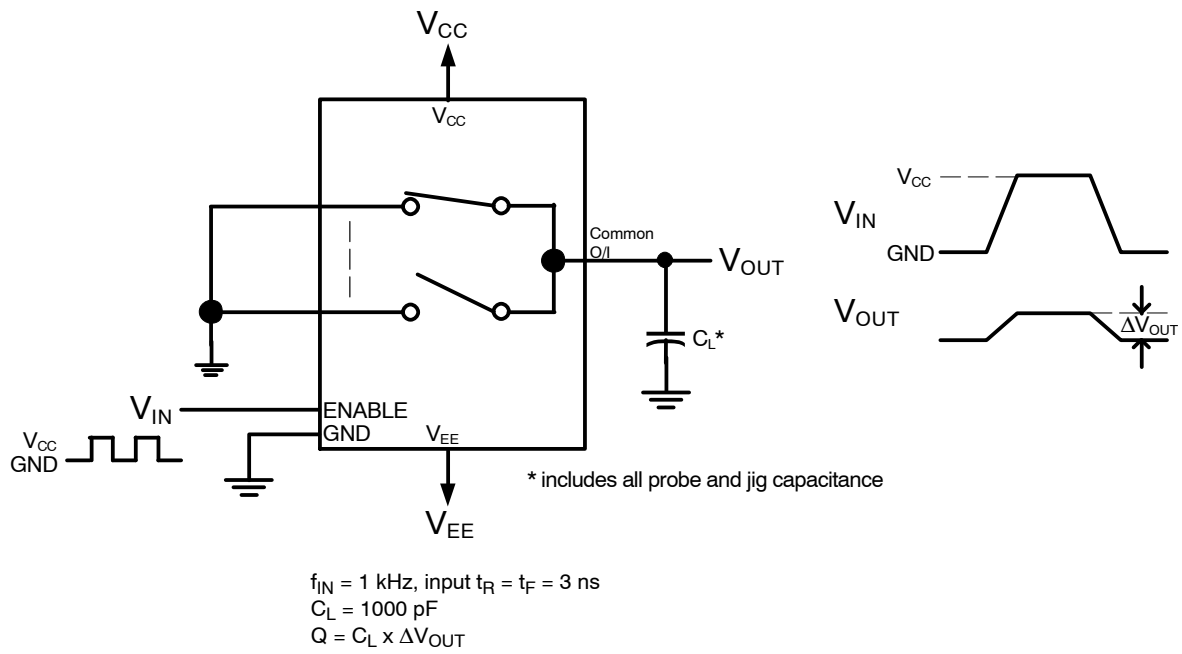

Figure 8. Charge Injection

MC74LVX4051, MC74LVX4052, MC74LVX4053, MC74LVXT4051, MC74LVXT4052, MC74LVXT4053

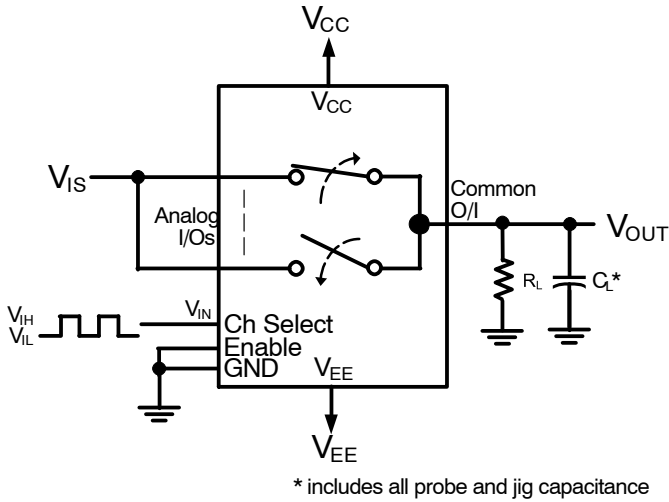

Figure 9. Break-Before-Make

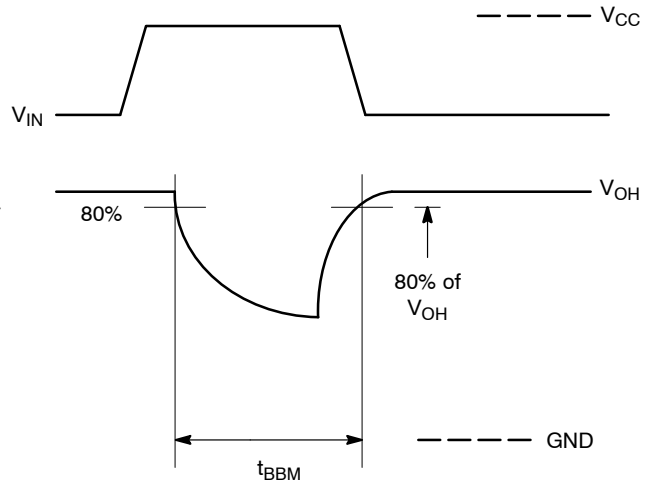

Figure 10. Break-Before-Make Time

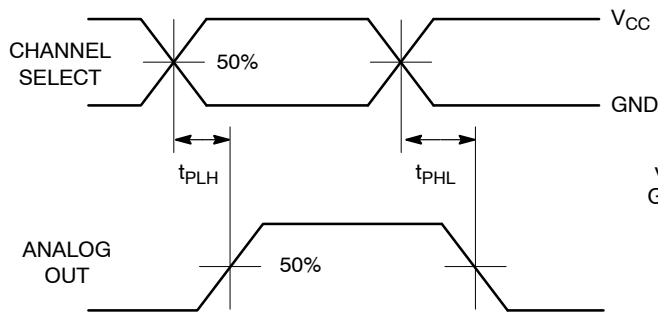

Figure 11. Propagation Delays, Channel Select to Analog Out

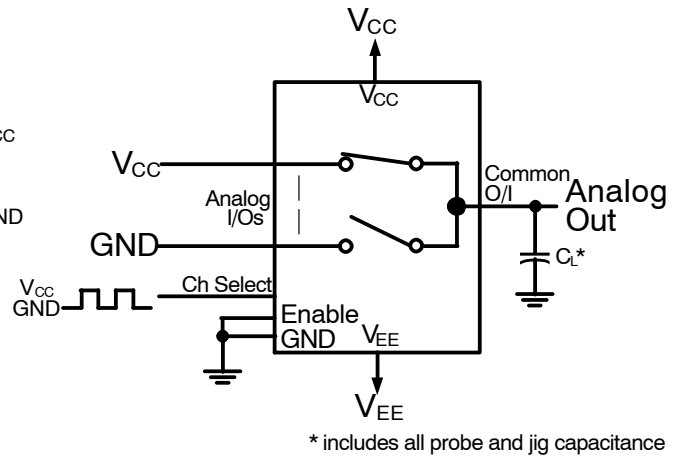

Figure 12. Propagation Delay, Select to Analog Out

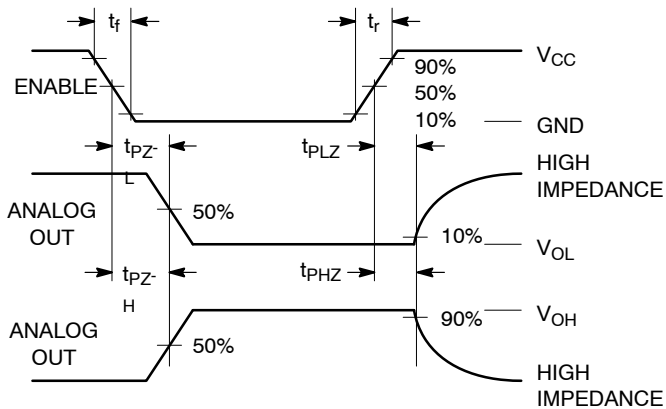

Figure 13. Propagation Delays, Enable to Analog Out

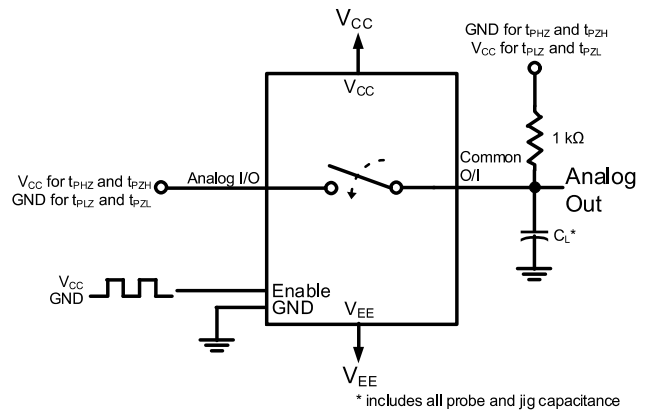

Figure 14. Propagation Delay, Enable to Analog Out

MC74LVX4051, MC74LVX4052, MC74LVX4053, MC74LVXT4051, MC74LVXT4052,
MC74LVXT4053

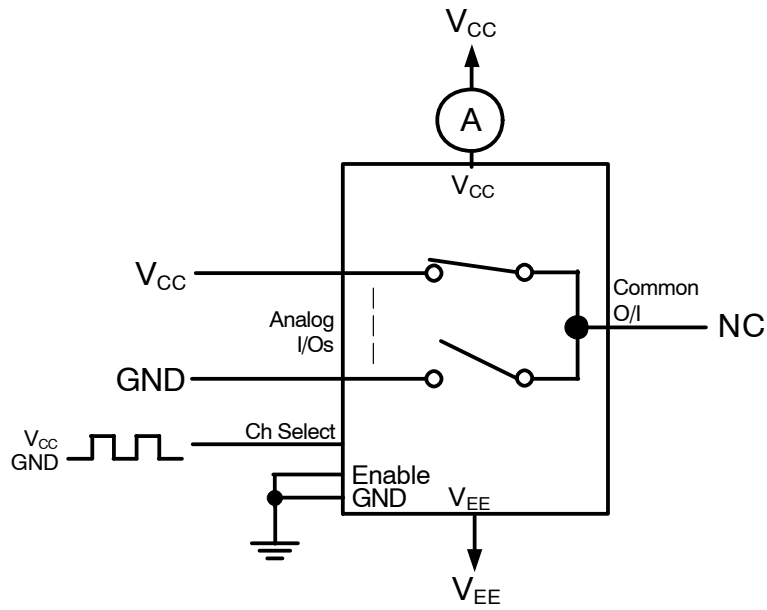
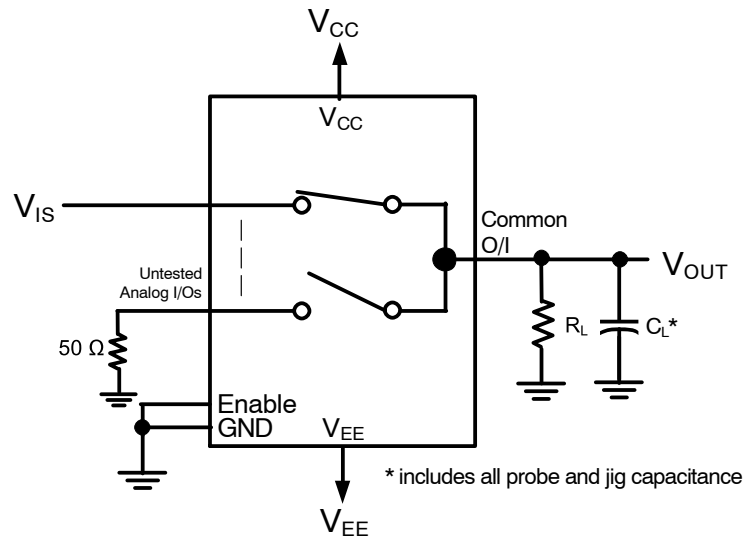

Figure 15. Power Dissipation Capacitance



$$DC\ Bias = (V_{CC} + V_{EE})/2$$

Figure 16. Total Harmonic Distortion

MC74LVX4051, MC74LVX4052, MC74LVX4053, MC74LVXT4051, MC74LVXT4052, MC74LVXT4053

APPLICATIONS INFORMATION

The Channel Select and Enable control pins should be at V_{CC} or GND logic levels. V_{CC} being recognized as a logic high and GND being recognized as a logic low. In this example:

$$\begin{aligned} V_{CC} &= +5 \text{ V} = \text{logic high} \\ \text{GND} &= 0 \text{ V} = \text{logic low} \end{aligned}$$

The maximum analog voltage swing is determined by the supply voltages V_{CC} and V_{EE} . The positive peak analog voltage should not exceed V_{CC} . Similarly, the negative peak analog voltage should not go below V_{EE} . In this example, the difference between V_{CC} and V_{EE} is five volts. Therefore, using the configuration of Figure 18, a maximum analog signal of five volts peak-to-peak can be controlled. Unused analog inputs/outputs may be left floating (i.e., not connected). However, tying unused analog inputs and

outputs to V_{CC} or GND through a low value resistor helps minimize crosstalk and feedthrough noise that may be picked up by an unused switch.

Although used here, balanced supplies are not a requirement. The only constraints on the power supplies are that:

$$\begin{aligned} V_{EE} - \text{GND} &= 0 \text{ to } -3.5 \text{ volts} \\ V_{CC} - \text{GND} &= 2.5 \text{ to } 6 \text{ volts} \\ V_{CC} - V_{EE} &= 2.5 \text{ to } 6 \text{ volts} \\ &\text{and } V_{EE} \leq \text{GND} \end{aligned}$$

When voltage transients above V_{CC} and/or below V_{EE} are anticipated on the analog channels, external Germanium or Schottky diodes (D_x) are recommended as shown in Figure 19. These diodes should be able to absorb the maximum anticipated current surges during clipping.

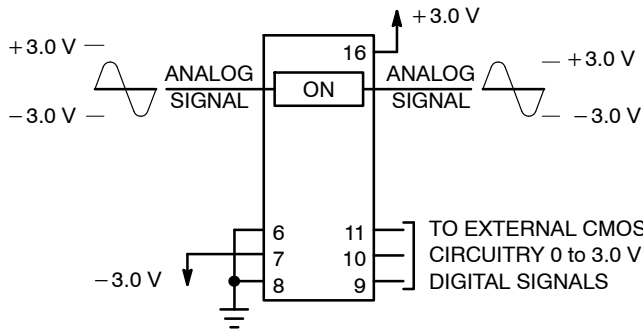

Figure 17. Application Example

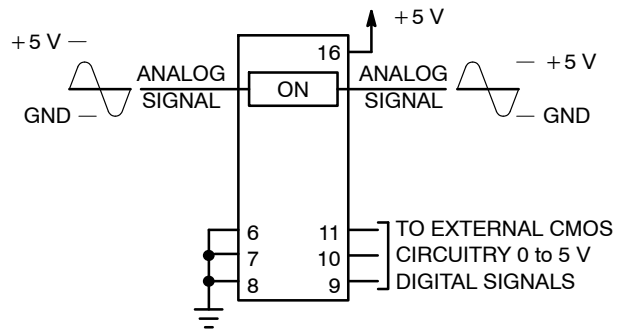

Figure 18. Application Example

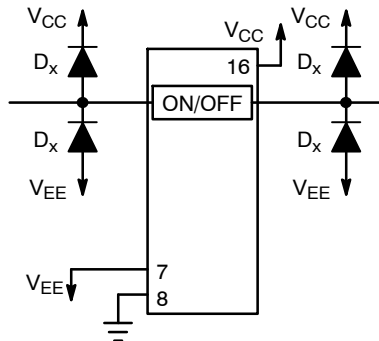

Figure 19. External Germanium or Schottky Clipping Diodes

MC74LVX4051, MC74LVX4052, MC74LVX4053, MC74LVXT4051, MC74LVXT4052, MC74LVXT4053

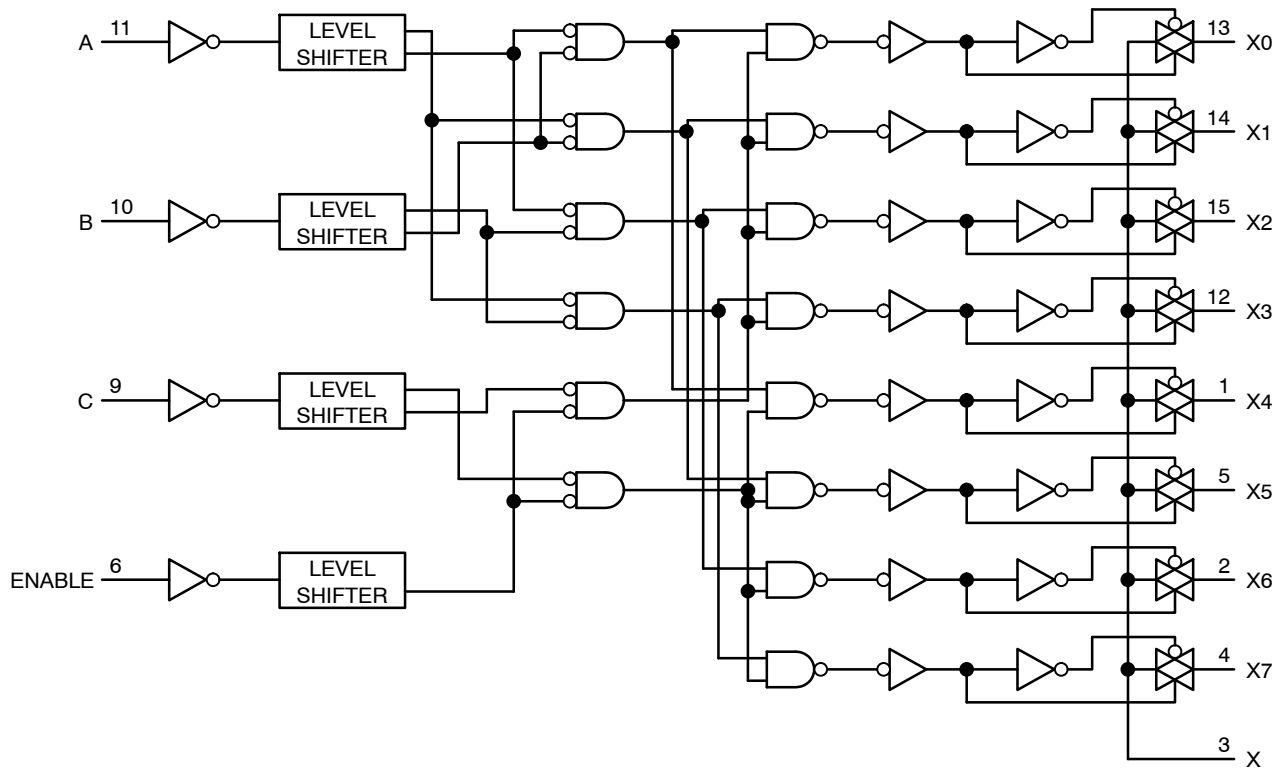

Figure 20. Function Diagram, 4051

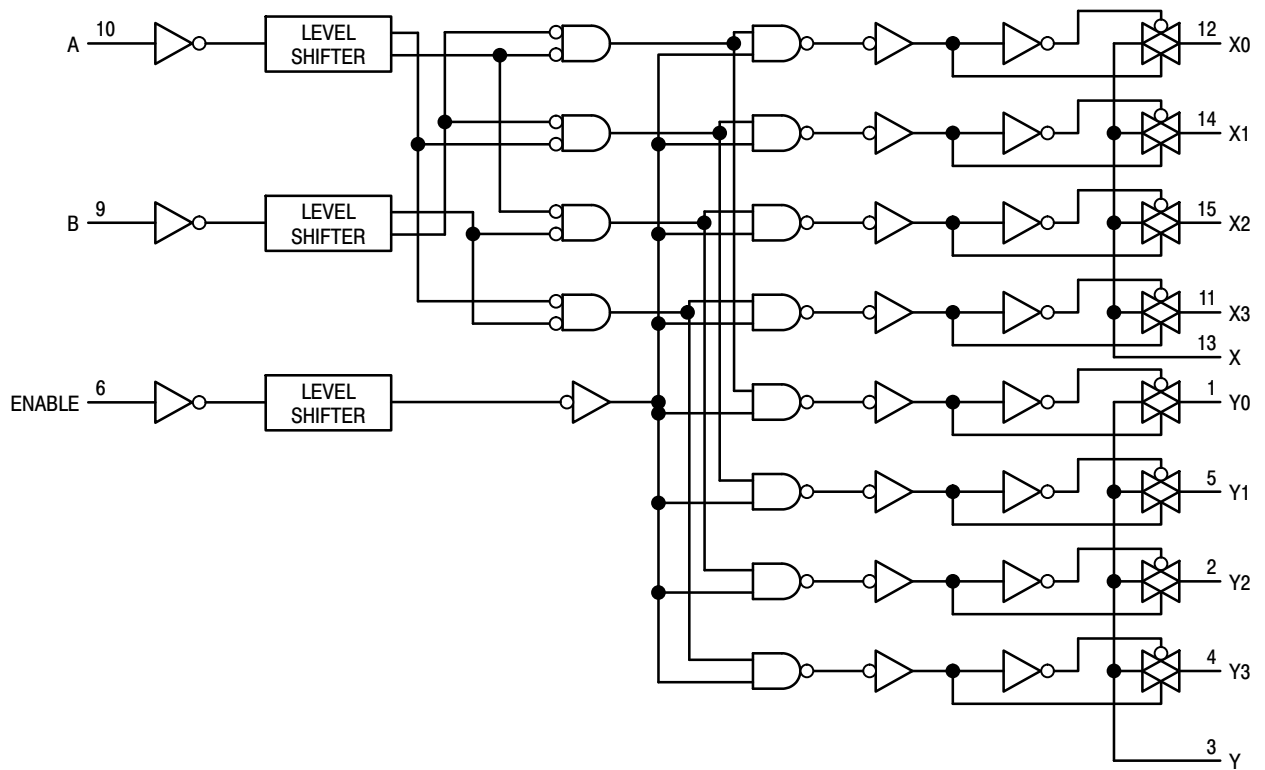

Figure 21. Function Diagram, 4052

**MC74LVX4051, MC74LVX4052, MC74LVX4053, MC74LVXT4051, MC74LVXT4052,
MC74LVXT4053**

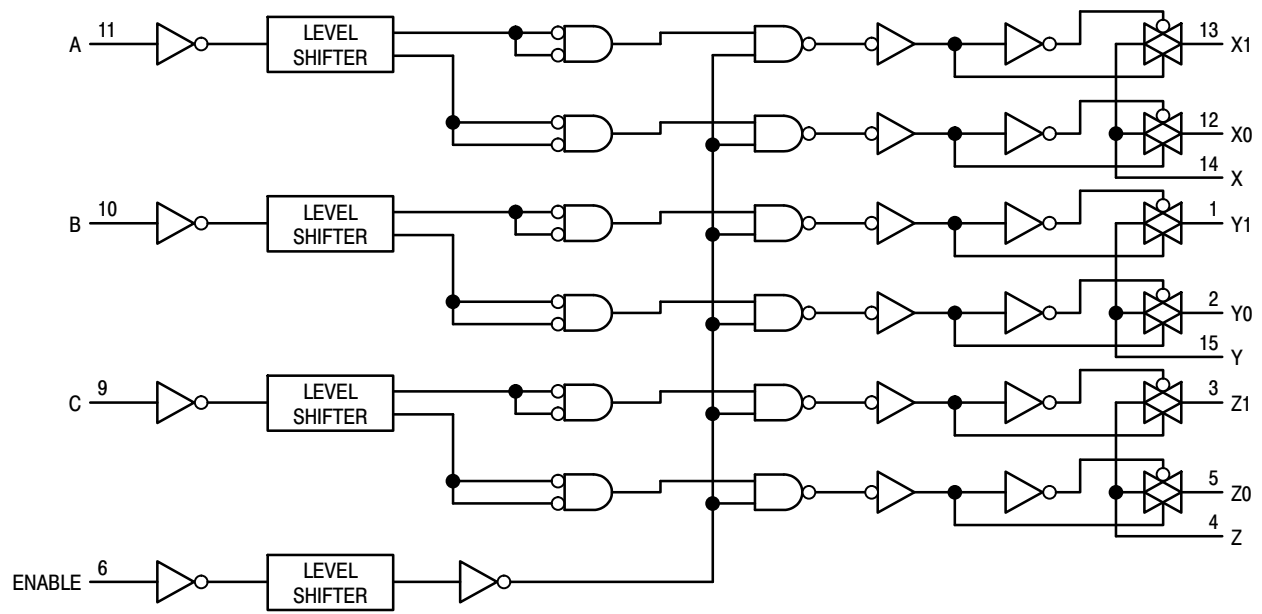

Figure 22. Function Diagram, 4053

**MC74LVX4051, MC74LVX4052, MC74LVX4053, MC74LVXT4051, MC74LVXT4052,
MC74LVXT4053**

ORDERING INFORMATION

Device	Marking	Package	Shipping†
MC74LVX4051DG	LVX4051G	SOIC-16	48 Units / Rail
MC74LVX4051DR2G	LVX4051G	SOIC-16	2500 / Tape & Reel
MC74LVX4051DTG	LVX 4051	TSSOP-16	96 Units / Rail
MC74LVX4051DTR2G	LVX 4051	TSSOP-16	2500 / Tape & Reel
MC74LVX4051MNTWG	4051	QFN-16	3000 / Tape & Reel (8mm pitch carrier tape)
MC74LVX4052DG	LVX4052G	SOIC-16	48 Units / Rail
MC74LVX4052DR2G	LVX4052G	SOIC-16	2500 / Tape & Reel
MC74LVX4052DTR2G	LVX 4052	TSSOP-16	2500 / Tape & Reel
MC74LVX4052DTR2G-Q*	LVX 4052	TSSOP-16	2500 / Tape & Reel
MC74LVX4053DG	LVX4053G	SOIC-16	48 Units / Rail
MC74LVX4053DTG	LVX 4053	TSSOP-16	96 Units / Rail
MC74LVXT4051DR2G	LVXT4051G	SOIC-16	2500 / Tape & Reel
MC74LVXT4051DTR2G	LVXT 4051	TSSOP-16	2500 / Tape & Reel
MC74LVXT4052DR2G	LVX4052G	SOIC-16	2500 / Tape & Reel
MC74LVXT4052DTG	LVX 4052	TSSOP-16	96 Units / Rail
MC74LVXT4052DTR2G	LVX 4052	TSSOP-16	2500 / Tape & Reel
MC74LVXT4053DR2G	LVX4053G	SOIC-16	2500 / Tape & Reel
MC74LVXT4053DTG	LVX 4053	TSSOP-16	96 Units / Rail
MC74LVXT4053DTR2G	LVX 4053	TSSOP-16	2500 / Tape & Reel

†For information on tape and reel specifications, including part orientation and tape sizes, please refer to our Tape and Reel Packaging Specifications Brochure, BRD8011/D.

*-Q Suffix for Automotive and Other Applications Requiring Unique Site and Control Change Requirements; AEC-Q100 Qualified and PPAP Capable.

MECHANICAL CASE OUTLINE PACKAGE DIMENSIONS



SCALE 2:1

QFN16, 2.5x3.5, 0.5P
CASE 485AW
ISSUE O

DATE 11 DEC 2008

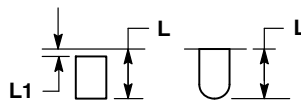
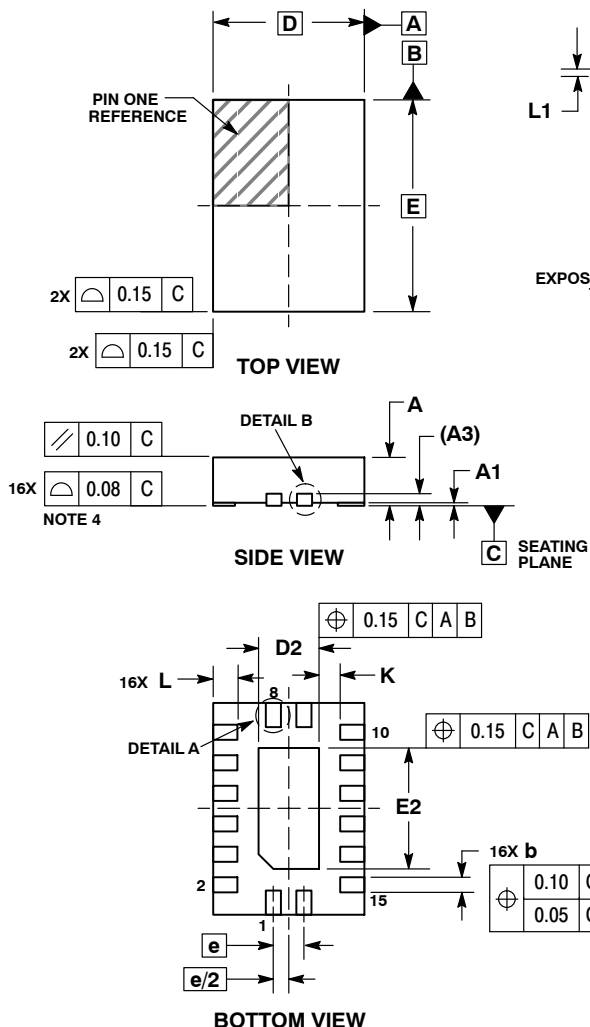

DETAIL A
ALTERNATE TERMINAL
CONSTRUCTIONS

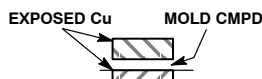

DETAIL B
ALTERNATE
CONSTRUCTIONS

NOTES:

1. DIMENSIONING AND TOLERANCING PER ASME Y14.5M, 1994.
2. CONTROLLING DIMENSION: MILLIMETERS.
3. DIMENSIONS b APPLIES TO PLATED TERMINAL AND IS MEASURED BETWEEN 0.15 AND 0.30 MM FROM TERMINAL.
4. COPLANARITY APPLIES TO THE EXPOSED PAD AS WELL AS THE TERMINALS.

DIM	MILLIMETERS	
	MIN	MAX
A	0.80	1.00
A1	0.00	0.05
A3	0.20 REF	
b	0.20	0.30
D	2.50 BSC	
D2	0.85	1.15
E	3.50 BSC	
E2	1.85	2.15
e	0.50 BSC	
K	0.20	---
L	0.35	0.45
L1	---	0.15

**GENERIC MARKING
DIAGRAM***

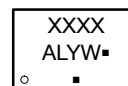

- XXXX = Specific Device Code
- A = Assembly Location
- L = Wafer Lot
- Y = Year
- W = Work Week
- = Pb-Free Package

(Note: Microdot may be in either location)

*This information is generic. Please refer to device data sheet for actual part marking. Pb-Free indicator, "G" or microdot "▪", may or may not be present. Some products may not follow the Generic Marking.

**RECOMMENDED
SOLDERING FOOTPRINT***

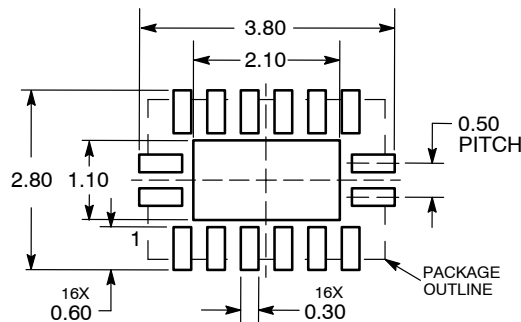

DIMENSIONS: MILLIMETERS

*For additional information on our Pb-Free strategy and soldering details, please download the **onsemi** Soldering and Mounting Techniques Reference Manual, SOLDERRM/D.

DOCUMENT NUMBER:	98AON36347E	Electronic versions are uncontrolled except when accessed directly from the Document Repository. Printed versions are uncontrolled except when stamped "CONTROLLED COPY" in red.
DESCRIPTION:	QFN16, 2.5X3.5, 0.5P	PAGE 1 OF 1

onsemi and **ONSEMI** are trademarks of Semiconductor Components Industries, LLC dba **onsemi** or its subsidiaries in the United States and/or other countries. **onsemi** reserves the right to make changes without further notice to any products herein. **onsemi** makes no warranty, representation or guarantee regarding the suitability of its products for any particular purpose, nor does **onsemi** assume any liability arising out of the application or use of any product or circuit, and specifically disclaims any and all liability, including without limitation special, consequential or incidental damages. **onsemi** does not convey any license under its patent rights nor the rights of others.

MECHANICAL CASE OUTLINE PACKAGE DIMENSIONS

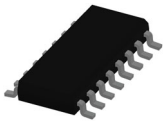

SOIC-16 9.90x3.90x1.50 1.27P
CASE 751B
ISSUE L

DATE 29 MAY 2024

NOTES:

1. DIMENSIONING AND TOLERANCING PER ASME Y14.5M, 2018.
2. DIMENSION IN MILLIMETERS. ANGLE IN DEGREES.
3. DIMENSIONS D AND E1 DO NOT INCLUDE MOLD PROTRUSION.
4. MAXIMUM MOLD PROTRUSION 0.15mm PER SIDE.
5. DIMENSION b DOES NOT INCLUDE DAMBAR PROTRUSION. ALLOWABLE DAMBAR PROTRUSION SHALL BE 0.127mm TOTAL IN EXCESS OF THE b DIMENSION AT MAXIMUM MATERIAL CONDITION.

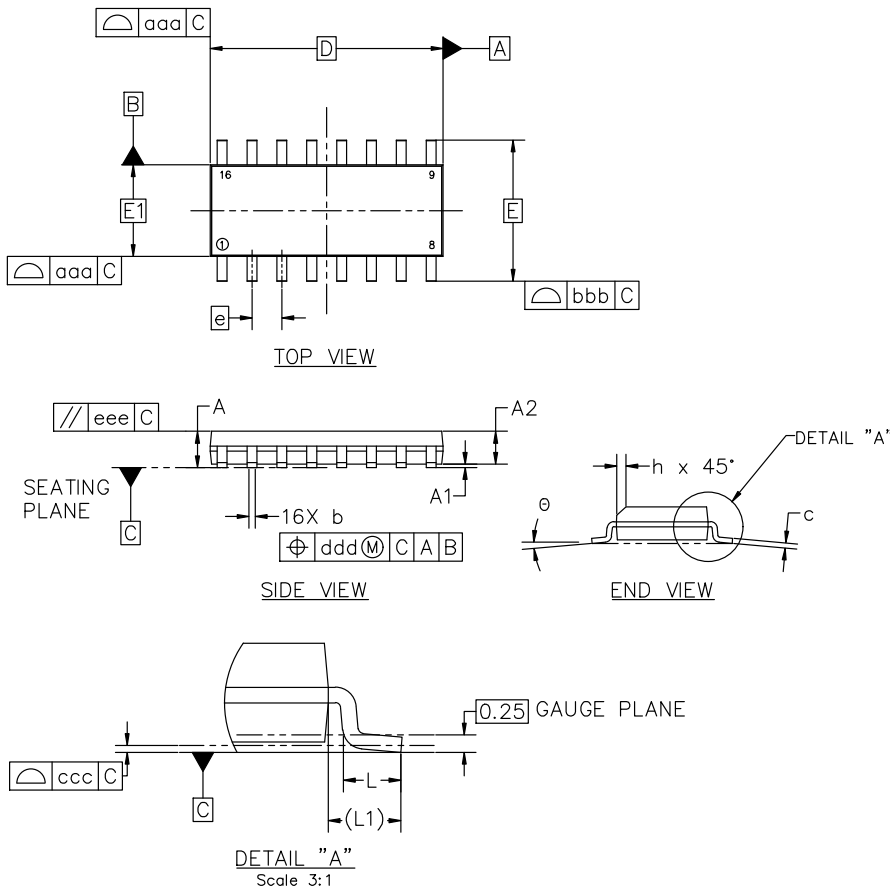

MILLIMETERS			
DIM	MIN	NOM	MAX
A	1.35	1.55	1.75
A1	0.00	0.05	0.10
A2	1.35	1.50	1.65
b	0.35	0.42	0.49
c	0.19	0.22	0.25
D	9.90 BSC		
E	6.00 BSC		
E1	3.90 BSC		
e	1.27 BSC		
h	0.25	---	0.50
L	0.40	0.83	1.25
L1	1.05 REF		
θ	0°	---	7°
TOLERANCE OF FORM AND POSITION			
aaa	0.10		
bbb	0.20		
ccc	0.10		
ddd	0.25		
eee	0.10		

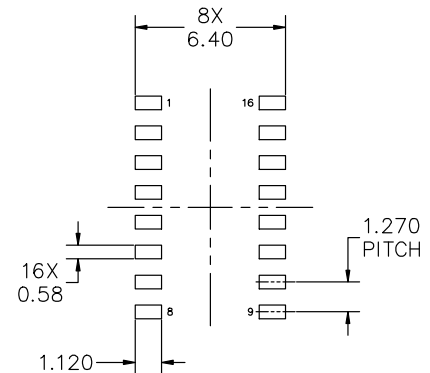

RECOMMENDED MOUNTING FOOTPRINT

*FOR ADDITIONAL INFORMATION ON OUR PB-FREE STRATEGY AND SOLDERING DETAILS, PLEASE DOWNLOAD THE onsemi SOLDERING AND MOUNTING TECHNIQUES REFERENCE MANUAL, SOLDERRM/D

DOCUMENT NUMBER:	98ASB42566B	Electronic versions are uncontrolled except when accessed directly from the Document Repository. Printed versions are uncontrolled except when stamped "CONTROLLED COPY" in red.
DESCRIPTION:	SOIC-16 9.90X3.90X1.50 1.27P	PAGE 1 OF 2

onsemi and ONSEMI are trademarks of Semiconductor Components Industries, LLC dba onsemi or its subsidiaries in the United States and/or other countries. onsemi reserves the right to make changes without further notice to any products herein. onsemi makes no warranty, representation or guarantee regarding the suitability of its products for any particular purpose, nor does onsemi assume any liability arising out of the application or use of any product or circuit, and specifically disclaims any and all liability, including without limitation special, consequential or incidental damages. onsemi does not convey any license under its patent rights nor the rights of others.

SOIC-16 9.90x3.90x1.50 1.27P
CASE 751B
ISSUE L

DATE 29 MAY 2024

GENERIC MARKING DIAGRAM*

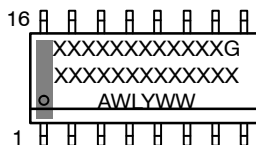

XXXXX = Specific Device Code
 A = Assembly Location
 WL = Wafer Lot
 Y = Year
 WW = Work Week
 G = Pb-Free Package

*This information is generic. Please refer to device data sheet for actual part marking. Pb-Free indicator, "G" or microdot "•", may or may not be present. Some products may not follow the Generic Marking.

<p>STYLE 1:</p> <p>PIN 1. COLLECTOR 2. BASE 3. EMITTER 4. NO CONNECTION 5. EMITTER 6. BASE 7. COLLECTOR 8. COLLECTOR 9. BASE 10. EMITTER 11. NO CONNECTION 12. EMITTER 13. BASE 14. COLLECTOR 15. EMITTER 16. COLLECTOR</p>	<p>STYLE 2:</p> <p>PIN 1. CATHODE 2. ANODE 3. NO CONNECTION 4. CATHODE 5. CATHODE 6. NO CONNECTION 7. ANODE 8. CATHODE 9. CATHODE 10. ANODE 11. NO CONNECTION 12. CATHODE 13. CATHODE 14. NO CONNECTION 15. ANODE 16. CATHODE</p>	<p>STYLE 3:</p> <p>PIN 1. COLLECTOR, DYE #1 2. BASE, #1 3. EMITTER, #1 4. COLLECTOR, #1 5. COLLECTOR, #2 6. BASE, #2 7. EMITTER, #2 8. COLLECTOR, #2 9. COLLECTOR, #3 10. BASE, #3 11. EMITTER, #3 12. COLLECTOR, #3 13. COLLECTOR, #4 14. BASE, #4 15. EMITTER, #4 16. COLLECTOR, #4</p>	<p>STYLE 4:</p> <p>PIN 1. COLLECTOR, DYE #1 2. COLLECTOR, #1 3. COLLECTOR, #2 4. COLLECTOR, #2 5. COLLECTOR, #3 6. COLLECTOR, #3 7. COLLECTOR, #4 8. COLLECTOR, #4 9. BASE, #4 10. EMITTER, #4 11. BASE, #3 12. EMITTER, #3 13. BASE, #2 14. EMITTER, #2 15. BASE, #1 16. EMITTER, #1</p>
<p>STYLE 5:</p> <p>PIN 1. DRAIN, DYE #1 2. DRAIN, #1 3. DRAIN, #2 4. DRAIN, #2 5. DRAIN, #3 6. DRAIN, #3 7. DRAIN, #4 8. DRAIN, #4 9. GATE, #4 10. SOURCE, #4 11. GATE, #3 12. SOURCE, #3 13. GATE, #2 14. SOURCE, #2 15. GATE, #1 16. SOURCE, #1</p>	<p>STYLE 6:</p> <p>PIN 1. CATHODE 2. CATHODE 3. CATHODE 4. CATHODE 5. CATHODE 6. CATHODE 7. CATHODE 8. CATHODE 9. ANODE 10. ANODE 11. ANODE 12. ANODE 13. ANODE 14. ANODE 15. ANODE 16. ANODE</p>	<p>STYLE 7:</p> <p>PIN 1. SOURCE N-CH 2. COMMON DRAIN (OUTPUT) 3. COMMON DRAIN (OUTPUT) 4. GATE P-CH 5. COMMON DRAIN (OUTPUT) 6. COMMON DRAIN (OUTPUT) 7. COMMON DRAIN (OUTPUT) 8. SOURCE P-CH 9. SOURCE P-CH 10. COMMON DRAIN (OUTPUT) 11. COMMON DRAIN (OUTPUT) 12. COMMON DRAIN (OUTPUT) 13. GATE N-CH 14. COMMON DRAIN (OUTPUT) 15. COMMON DRAIN (OUTPUT) 16. SOURCE N-CH</p>	

DOCUMENT NUMBER:	98ASB42566B	Electronic versions are uncontrolled except when accessed directly from the Document Repository. Printed versions are uncontrolled except when stamped "CONTROLLED COPY" in red.
DESCRIPTION:	SOIC-16 9.90X3.90X1.50 1.27P	PAGE 2 OF 2

onsemi and onsemi are trademarks of Semiconductor Components Industries, LLC dba onsemi or its subsidiaries in the United States and/or other countries. onsemi reserves the right to make changes without further notice to any products herein. onsemi makes no warranty, representation or guarantee regarding the suitability of its products for any particular purpose, nor does onsemi assume any liability arising out of the application or use of any product or circuit, and specifically disclaims any and all liability, including without limitation special, consequential or incidental damages. onsemi does not convey any license under its patent rights nor the rights of others.

MECHANICAL CASE OUTLINE PACKAGE DIMENSIONS

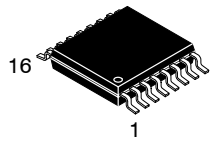

TSSOP-16 WB
CASE 948F
ISSUE B

DATE 19 OCT 2006

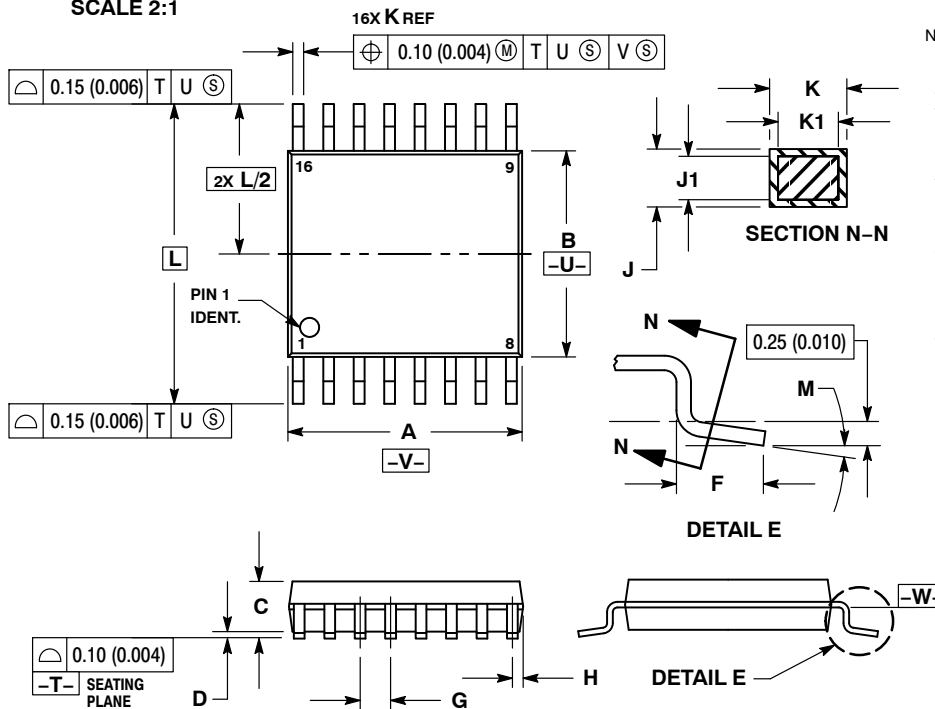

NOTES:

1. DIMENSIONING AND TOLERANCING PER ANSI Y14.5M, 1982.
2. CONTROLLING DIMENSION: MILLIMETER.
3. DIMENSION A DOES NOT INCLUDE MOLD FLASH, PROTRUSIONS OR GATE BURRS. MOLD FLASH OR GATE BURRS SHALL NOT EXCEED 0.15 (0.006) PER SIDE.
4. DIMENSION B DOES NOT INCLUDE INTERLEAD FLASH OR PROTRUSION. INTERLEAD FLASH OR PROTRUSION SHALL NOT EXCEED 0.25 (0.010) PER SIDE.
5. DIMENSION K DOES NOT INCLUDE DAMBAR PROTRUSION. ALLOWABLE DAMBAR PROTRUSION SHALL BE 0.08 (0.003) TOTAL IN EXCESS OF THE K DIMENSION AT MAXIMUM MATERIAL CONDITION.
6. TERMINAL NUMBERS ARE SHOWN FOR REFERENCE ONLY.
7. DIMENSION A AND B ARE TO BE DETERMINED AT DATUM PLANE -W-.

DIM	MILLIMETERS		INCHES	
	MIN	MAX	MIN	MAX
A	4.90	5.10	0.193	0.200
B	4.30	4.50	0.169	0.177
C	---	1.20	---	0.047
D	0.05	0.15	0.002	0.006
F	0.50	0.75	0.020	0.030
G	0.65 BSC		0.026 BSC	
H	0.18	0.28	0.007	0.011
J	0.09	0.20	0.004	0.008
J1	0.09	0.16	0.004	0.006
K	0.19	0.30	0.007	0.012
K1	0.19	0.25	0.007	0.010
L	6.40 BSC		0.252 BSC	
M	0°	8°	0°	8°

**RECOMMENDED
SOLDERING FOOTPRINT***

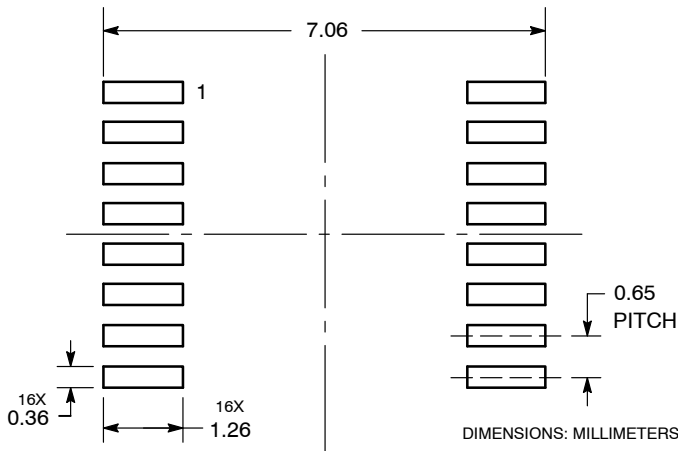

**GENERIC
MARKING DIAGRAM***

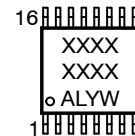

- XXXX = Specific Device Code
- A = Assembly Location
- L = Wafer Lot
- Y = Year
- W = Work Week
- G or ■ = Pb-Free Package

*This information is generic. Please refer to device data sheet for actual part marking. Pb-Free indicator, "G" or microdot "■", may or may not be present. Some products may not follow the Generic Marking.

*For additional information on our Pb-Free strategy and soldering details, please download the **onsemi** Soldering and Mounting Techniques Reference Manual, SOLDERRM/D.

DOCUMENT NUMBER:	98ASH70247A	Electronic versions are uncontrolled except when accessed directly from the Document Repository. Printed versions are uncontrolled except when stamped "CONTROLLED COPY" in red.
DESCRIPTION:	TSSOP-16	PAGE 1 OF 1

onsemi and onsemi are trademarks of Semiconductor Components Industries, LLC dba onsemi or its subsidiaries in the United States and/or other countries. onsemi reserves the right to make changes without further notice to any products herein. onsemi makes no warranty, representation or guarantee regarding the suitability of its products for any particular purpose, nor does onsemi assume any liability arising out of the application or use of any product or circuit, and specifically disclaims any and all liability, including without limitation special, consequential or incidental damages. onsemi does not convey any license under its patent rights nor the rights of others.

onsemi, **Onsemi**, and other names, marks, and brands are registered and/or common law trademarks of Semiconductor Components Industries, LLC dba "**onsemi**" or its affiliates and/or subsidiaries in the United States and/or other countries. **onsemi** owns the rights to a number of patents, trademarks, copyrights, trade secrets, and other intellectual property. A listing of **onsemi**'s product/patent coverage may be accessed at www.onsemi.com/site/pdf/Patent-Marking.pdf. **onsemi** reserves the right to make changes at any time to any products or information herein, without notice. The information herein is provided "as-is" and **onsemi** makes no warranty, representation or guarantee regarding the accuracy of the information, product features, availability, functionality, or suitability of its products for any particular purpose, nor does **onsemi** assume any liability arising out of the application or use of any product or circuit, and specifically disclaims any and all liability, including without limitation special, consequential or incidental damages. Buyer is responsible for its products and applications using **onsemi** products, including compliance with all laws, regulations and safety requirements or standards, regardless of any support or applications information provided by **onsemi**. "Typical" parameters which may be provided in **onsemi** data sheets and/or specifications can and do vary in different applications and actual performance may vary over time. All operating parameters, including "Typicals" must be validated for each customer application by customer's technical experts. **onsemi** does not convey any license under any of its intellectual property rights nor the rights of others. **onsemi** products are not designed, intended, or authorized for use as a critical component in life support systems or any FDA Class 3 medical devices or medical devices with a same or similar classification in a foreign jurisdiction or any devices intended for implantation in the human body. Should Buyer purchase or use **onsemi** products for any such unintended or unauthorized application, Buyer shall indemnify and hold **onsemi** and its officers, employees, subsidiaries, affiliates, and distributors harmless against all claims, costs, damages, and expenses, and reasonable attorney fees arising out of, directly or indirectly, any claim of personal injury or death associated with such unintended or unauthorized use, even if such claim alleges that **onsemi** was negligent regarding the design or manufacture of the part. **onsemi** is an Equal Opportunity/Affirmative Action Employer. This literature is subject to all applicable copyright laws and is not for resale in any manner.

ADDITIONAL INFORMATION

TECHNICAL PUBLICATIONS:

Technical Library: www.onsemi.com/design/resources/technical-documentation
onsemi Website: www.onsemi.com

ONLINE SUPPORT: www.onsemi.com/support

For additional information, please contact your local Sales Representative at www.onsemi.com/support/sales



Looking for pricing, stock, or lifecycle information?

Click below to explore more details on WIN SOURCE:

- ⊖ [View MC74LVX4051DG on WIN SOURCE](#)
- ⊖ [ON Semiconductor Information](#)

Optimize Your Supply Chain with WIN SOURCE Solutions

- ✓ Global Sourcing Solution
- ✓ Obsolete Management
- ✓ Cost Control Management
- ✓ Shortage Management
- ✓ Alternative Solution
- ✓ Excess Inventory Management