



**THE DATASHEET OF
IR3887MTRPBFAUMA1**



IR3887 OptiMOS™ IPOL

30 A single-voltage synchronous Buck regulator

Features

- Single 4.3 V to 17 V application or Wide Input Voltage Range from 2.0 V to 17 V with an External VCC
- Precision Reference Voltage (0.6 V +/- 0.5%)
- Enhanced Fast COT engine stable with Ceramic Output Capacitors and No External Compensation
- Optional Forced Continuous Conduction Mode and Diode Emulation for Enhanced Light Load Efficiency
- Programmable Switching Frequency from 600 kHz to 2 MHz
- Monotonic Start-Up with Four Selectable Soft-Start Time & Enhanced Pre-Bias Start-Up
- Thermally Compensated Internal Over Current Protection with Four Selectable Settings
- Enable input with Voltage Monitoring Capability & Power Good Output
- Thermal Shut Down
- Operating Temp: $-40\text{ °C} < T_j < 125\text{ °C}$
- Small Size: 4 mm x 5 mm PQFN
- Halogen-free and RoHS2 Compliant with Exemption 7a

Potential applications

- Server Applications
- Storage Applications
- Telecom & Datacom Applications
- Distributed Point of Load Power Architectures

Product validation

Qualified for industrial applications according to the relevant tests of JEDEC47/20/22

Description

The IR3887 is an easy-to-use, fully integrated dc - dc Buck regulator. The onboard PWM controller and OptiMOS™ FETs with integrated bootstrap diode make IR3887 a small footprint solution, providing high-efficient power delivery. Furthermore, it uses a fast Constant On-Time (COT) control scheme, which simplifies the design efforts and achieves fast control response.

The IR3887 has an internal low dropout voltage regulator, allowing operations with a single supply. It can also operate with an external bias supply, extending the operating input voltage (P_{Vin}) range from 2.0 V to 17 V.

The IR3887 is a versatile regulator, offering programmable switching frequency from 600 kHz to 2 MHz, four selectable current limits, four selectable soft-start time, Forced Continuous Conduction Mode (FCCM) and Diode Emulation Mode (DEM) operation.

It also features important protection functions, such as pre-bias start-up, thermally compensated current limit, over voltage and under voltage protection, and thermal shutdown to give required system level security in the event of fault conditions.

Table of contents

Features	1
Potential applications	1
Product validation	1
Description	1
Table of contents	2
1 Ordering information	4
2 Functional block diagram.....	5
3 Typical application diagram	6
4 Pin descriptions	7
5 Absolute maximum ratings	9
6 Thermal Characteristics.....	10
6.1 Thermal Characteristics	10
7 Electrical specifications	11
7.1 Recommended operating conditions.....	11
7.2 Electrical characteristics.....	12
8 Typical efficiency and power loss curves.....	15
8.1 $P_{V_{in}} = V_{in} = 12\text{ V}, F_{sw} = 600\text{ kHz}$	15
8.2 $P_{V_{in}} = V_{in} = 12\text{ V}, F_{sw} = 800\text{ kHz}$	16
8.3 $P_{V_{in}} = V_{in} = 12\text{ V}, F_{sw} = 1000\text{ kHz}$	17
8.4 $P_{V_{in}} = V_{in} = V_{CC} = 5\text{ V}, F_{sw} = 600\text{ kHz}$	18
9 Thermal De-rating curves.....	19
10 $R_{DS(ON)}$ of MOSFET Over Temperature	20
11 Typical operating characteristics ($-40\text{ °C} \leq T_j \leq +125\text{ °C}$).....	21
12 Theory of operation.....	24
12.1 Fast Constant On-Time Control	24
12.2 Enable	24
12.3 FCCM and DEM Operation	25
12.4 Pseudo Constant Switching Frequency.....	25
12.5 Soft-start.....	26
12.6 Pre-bias Start-up	27
12.7 Internal Low - Dropout (LDO) Regulator.....	27
12.8 Over Current Protection (OCP)	28
12.9 Under Voltage Protection (UVP)	29
12.10 Over Voltage Protection (OVP).....	29
12.11 Over Temperature Protection (OTP)	30
12.12 Power Good (PGood) Output	30
12.13 Minimum On - Time and Minimum Off - Time	31
12.14 Selection of Feedforward Capacitor and Feedback Resistors.....	31
12.15 Resistors for Configuration Pins	32
13 Design example.....	33
13.1 Enabling the IR3887.....	33
13.2 Programming the Switching Frequency and Operation Mode.....	33
13.3 Selecting Input Capacitors.....	33
13.4 Inductor Selection.....	34

Table of contents

13.5	Output Capacitor Selection	34
13.6	Output Voltage Programming.....	35
13.7	Feedforward Capacitor	35
13.8	Bootstrap Capacitor	35
13.9	VIN, and VCC/LDO bypass Capacitor	35
14	Application Information.....	36
14.1	Application Diagram.....	36
14.2	Typical Operating Waveforms.....	36
15	Layout Recommendations.....	39
15.1	Solder Mask	43
15.2	Stencil Design	44
16	Package	45
16.1	Marking Information	45
16.2	Dimensions	45
16.3	Tape and Reel Information	47
17	Environmental Qualifications	48
18	Evaluation Boards and Support Documentation	49
	Revision history.....	50

Ordering information

1 Ordering information

1. Ordering Information

Sales Product Name	Package Type	Standard Pack Form and Qty		Orderable Part Number
IR3887MTRPBF	QFN 4 mm x 5 mm	Tape and Reel	5000	IR3887MTRPBF AUMA1

Packing type	Tape & Reel
Moisture protection packing	Dry
Packing size	330 mm

Halogen Free	Yes
RoHS compliant	Yes
Total lead free	No

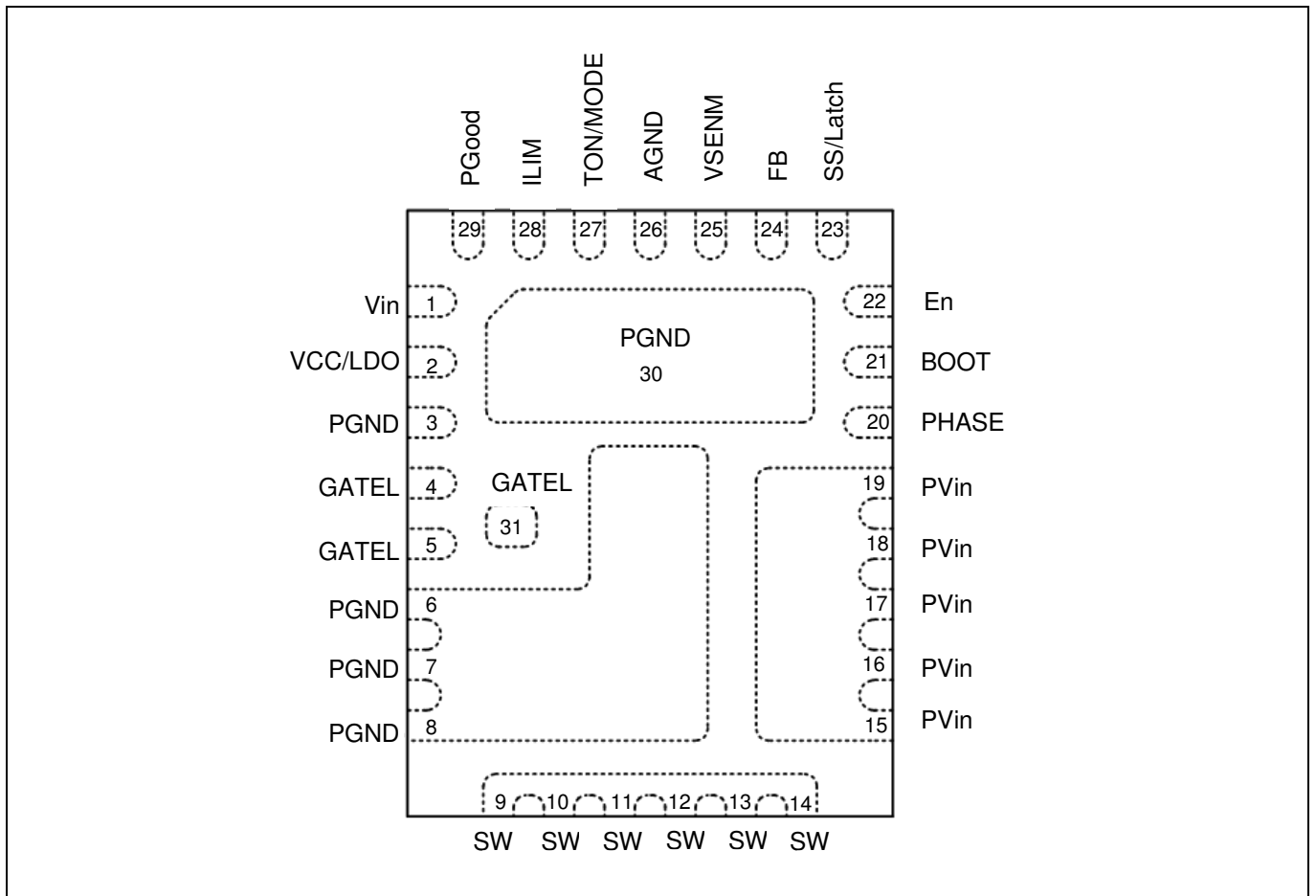

Figure 1 Package Top View

2 Functional block diagram

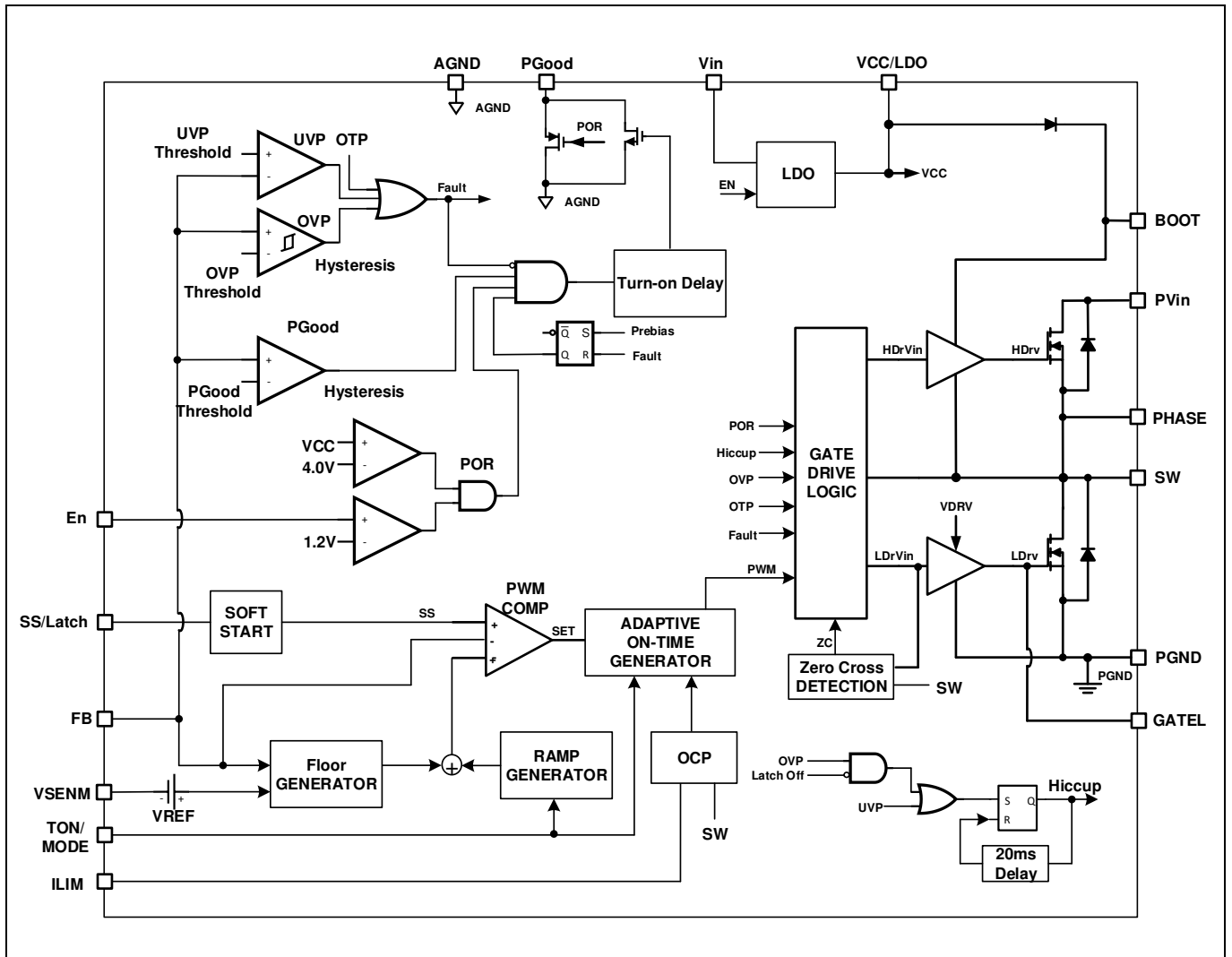

Figure 2 Block diagram

3 Typical application diagram

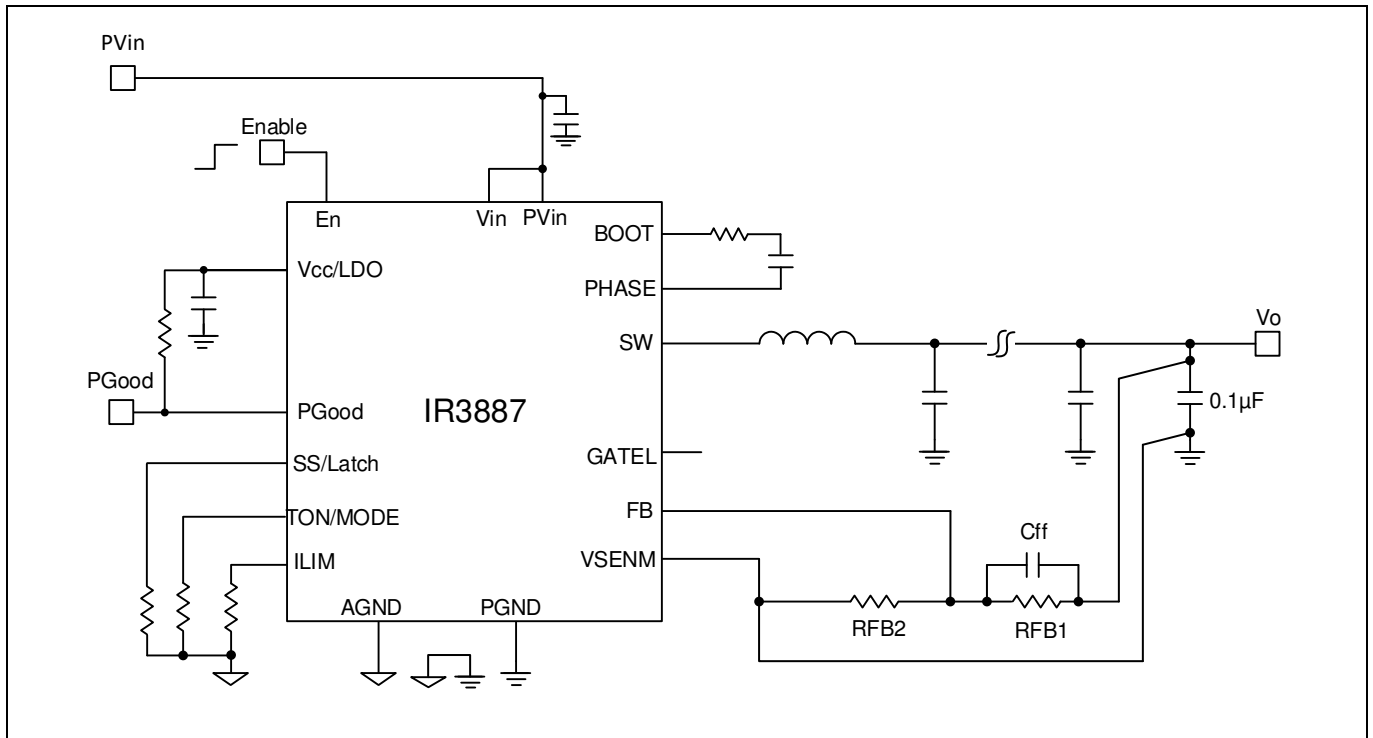

Figure 3 IR3887 basic application circuit

Pin descriptions

4 Pin descriptions

Note: I = Input, O = Output

Pin#	Pin Name	I/O	Type	Pin Description
1	Vin	I	Power	Input voltage for an Internal LDO. A 4.7 μ F capacitor should be connected between this pin and PGnd. If an external supply is connected to VCC/LDO pin, this pin should be shorted to VCC/LDO pin and a 10 μ F ceramic capacitor can be shared with Vin and VCC/LDO pin.
2	VCC/LDO	I/O	Power	Input bias for an external VCC voltage or output of the internal LDO. A 2.2 μ F - 10 μ F ceramic capacitor is recommended to use between VCC and the Power ground (PGND).
3, 6, 7, 8, 30	PGND	-	Ground	Power Ground. Should be connected to the system's power ground plane. PGND and AGND are internally connected via the lead frame.
4, 5, 31	GATEL	I	Analog	Gate of Low-side FET. This pin can be used to monitor the gate signal of LS FET. No external components should be connected to it.
9, 10, 11, 12, 13, 14	SW	O	Power	Switch Node. Connect these pins to an output inductor.
15, 16, 17, 18, 19	PVin	I	Power	Input supply for the power stage.
20	PHASE	O	Analog	Source of High-side FET. Connect a bootstrap capacitor between this pin and BOOT pin. A high temperature (x7R) 0.1 μ F or greater value ceramic capacitor is recommended.
21	BOOT	I	Analog	Supply voltage for the high side driver. Connect this pin to the PHASE pin through a bootstrap capacitor. For PVin above 14 V, a resistor (e.g., 1 Ω ~2 Ω) is recommended in series with the bootstrap capacitor to control the slew rate of the SW node rising edge.
22	En	I	Analog	Enable pin to turn the IC on and off.
23	SS/Latch	I	Analog	Multi-function pin. Connect this pin to a quiet ground with a resistor to select Soft-Start time from 4 options. This pin also selects latched-off Over Voltage Protection (OVP) or non-latched OVP.
24	FB	I	Analog	Output voltage feedback pin. Connect this pin to the output of the regulator via a resistor divider to set the output voltage.
25	VSENM	-	Analog	This pin provides the return connection for a pseudo remote voltage sensing. The feedback resistor divider should be connected to this pin. It is also used as ground for the internal reference voltage.
26	AGND	-	Ground	Signal ground for the internal circuitry except of the internal reference voltage.
27	TON/MODE	I	Analog	Multi-function pin. This pin sets the switching frequency to 1 of 8 settings and sets the mode of operation to FCCM or DEM.

Pin descriptions

Pin#	Pin Name	I/O	Type	Pin Description
28	ILIM	I	Analog	Connecting a resistor to a quite ground sets the Over Current Protection (OCP) limit. Four user selectable OCP limits are available.
29	PGood	O	Analog	Power Good status output pin is open drain. Connect a pull up resistor from this pin to VCC or to an external bias voltage, e.g. 3.3 V.

Absolute maximum ratings

5 Absolute maximum ratings

Absolute maximum ratings

Description	Min	Max	Unit	Conditions
PVin, Vin, En to PGND	-0.3	25	V	Note 1
PVin to SW and PHASE	-0.3 V(dc) , below -5 V for 5 ns	25 V(dc), above 32 V for 2 ns	V	
VCC to PGND	-0.3	6	V	Note 1
Boot to PGND	-0.3 V(dc), below -0.3 V for 5 ns	29	V	Note 1
SW and PHASE to PGND	-0.3 (dc), below -5 V for 5 ns	25 V(dc), above 32 V for 2 ns	V	Note 1
BOOT to PHASE	-0.3	6 V(dc), 7 V for 5 ns	V	
ILIM, FB, PGood, TON/MODE, GATEL and SS to GND	-0.3	6	V	Note 1
PGND to AGND	-0.3	0.3	V	
VSENM to AGND	-0.3	0.3	V	
Storage Temperature Range	-55	150	°C	
Junction Temperature Range	-40	150	°C	

Note:

1. PGND, VSENM, and AGND pin are connected together

Attention: *Stresses beyond these listed under “Absolute Maximum Ratings” may cause permanent damage to the device. These are stress ratings only and functional operation of the device at these or any other conditions beyond those indicated in the operational sections of the specifications are not implied.*

6 Thermal Characteristics

6.1 Thermal Characteristics

Description	Symbol	Values	Test Conditions
Junction to Ambient Thermal Resistance	θ_{JA}	18 °C/W	Note 2
Junction to PCB Thermal Resistance	θ_{JC-PCB}	1 °C/W	Note 3
Junction to Case Top Thermal Resistance	θ_{JC}	26 °C/W	

Note:

2. Thermal resistance is measured with components mounted on a standard EVAL_3887_1Vout demo board in free air.
3. Thermal resistance is based on the board temperature near the pin 17.

7 Electrical specifications

7.1 Recommended operating conditions

Description	Min	Max	Unit	Note
PVin Voltage Range with External VCC	2	17	V	Note 4, Note 5
PVin Voltage Range with Internal LDO	4.5	17	V	Note 5, Note 6 & 10
VCC Supply Voltage Range	4.3	5.5	V	Note 4, Note 7
Typical Output Voltage Range	0.6	6	V	Note 8, Note 9
Continuous Output Current Range		30	A	Note 9
Typical Switching Frequency	600	2000	kHz	Note 10
Operating Junction Temperature	-40	125	°C	

Note:

4. *Vin is shorted to VCC and use an external bias voltage.*
5. *A common practice is to have 20% margin on the maximum SW node voltage in the design. For applications requiring PVin equal to or above 14 V, a small resistor in series with the Boot pin should be used to ensure the maximum SW node spike voltage does not exceed 20 V. Alternatively, a RC snubber can be used at the SW node to reduce the SW node spike.*
6. *Vin is connected to PVin and the internal LDO is used. For single-rail applications with the internal LDO and PVin = Vin = 4.3 V-5.4 V, the internal LDO may enter dropout mode. OCP limits can be reduced due to the lower VCC voltage. Please refer to [Section 12.7](#) for more detailed design guidelines.*
7. *The IR3887 is designed to function with VCC down to 4.2 V, however, electrical specifications such as OCP limits may be degraded.*
8. *The maximum output voltage is also limited by the minimum off-time. Please refer to [Section 12.13](#) for details. Also note that OCP limit may be degraded when off-time is close to the minimum off-time.*
9. *Refer to [Section 9](#) for maximum output current rating at different ambient temperatures.*
10. *The maximum LDO output current must be limited within 50 mA for operations requiring full operating temperature range of $-40\text{ °C} \leq T_J \leq 125\text{ °C}$. [Figure 6](#) shows the maximum LDO output current capability over junction temperature. Thermal de-rating may be needed at an elevated ambient temperature to ensure the junction temperature within the recommended operating range.*

IR3887 OptiMOS™ IPOL

30 A single-voltage synchronous Buck regulator



Electrical specifications

7.2 Electrical characteristics

Note: Unless otherwise specified, the specifications apply over, $4.5\text{ V} \leq V_{in} = P_{Vin} \leq 17\text{ V}$, $0\text{ }^{\circ}\text{C} < T_j < 125\text{ }^{\circ}\text{C}$. Typical values are specified at $T_a = 25\text{ }^{\circ}\text{C}$.

Parameter	Symbol	Conditions	Min	Typ	Max	Unit
Power Stage						
Top Switch	$R_{ds(on)_Top}$	$V_{Boot} - V_{sw} = 5.0\text{ V}$, $I_o = 30\text{ A}$, $T_j = 25\text{ }^{\circ}\text{C}$		2.4		m Ω
Bottom Switch	$R_{ds(on)_Bot}$	$V_{CC} = 5.0\text{ V}$, $I_o = 30\text{ A}$, $T_j = 25\text{ }^{\circ}\text{C}$		0.8		
Bootstrap Forward Voltage		$I(\text{Boot}) = 25\text{ mA}$		280	600	mV
SW float voltage	V_{sw}	$En = 0\text{ V}$			300	mV
		$En = \text{high}$, No Switching			300	
Dead Band Time	T_{db}	SW node falling edge, $I_o = 30\text{ A}$, Internal LDO, $T_j = 25\text{ }^{\circ}\text{C}$, Note 11		10		ns
		SW node rising edge, $I_o = 30\text{ A}$, Internal LDO, $T_j = 25\text{ }^{\circ}\text{C}$, Note 11		5		ns
Supply Current						
Vin Supply Current (standby)	$I_{in(\text{Standby})}$	$En = \text{Low}$, No Switching		1.7	10	μA
Vin Supply Current (static)	$I_{in(\text{Static})}$	$En = 2\text{ V}$, No Switching		2.3	4	mA
Soft Start						
Soft Start Ramp Rate	SS rate	SS/Latch = 0 k Ω , 4.53 k Ω , 10.5 k Ω , 18.7 k Ω ;	0.4	0.6	0.84	mV/ μs
		SS/Latch = 1.5 k Ω , 5.76 k Ω , 12.1 k Ω , 21.5 k Ω ;	0.2	0.3	0.42	
		SS/Latch = 2.49 k Ω , 7.32 k Ω , 14 k Ω , 24.9 k Ω , Floating	0.1	0.15	0.21	
		SS/Latch = 3.48 k Ω , 8.87 k Ω , 16.2 k Ω , 28.7 k Ω ;	0.05	0.075	0.105	
Feedback Voltage						
Feedback Voltage	V_{FB}			0.6		V
Accuracy		$0\text{ }^{\circ}\text{C} < T_j < 85\text{ }^{\circ}\text{C}$	-0.5		+0.5	%
		$-40\text{ }^{\circ}\text{C} < T_j < 125\text{ }^{\circ}\text{C}$, Note 12	-1		1	
V_{FB} Input Current	$I_{V_{FB}}$	$V_{FB} = 0.6\text{ V}$, $T_j = 25\text{ }^{\circ}\text{C}$	-150	0	+150	nA
On-Time Timer Control						
On Time	T_{on}	$V_{in} = 12\text{ V}$, $V_o = 1\text{ V}$, TON = 0 k Ω , or 10.5 k Ω , Note 13		151		ns
		$V_{in} = 12\text{ V}$, $V_o = 1\text{ V}$, TON = 1.5 k Ω , or 12.1 k Ω , Note 13		114		
		$V_{in} = 12\text{ V}$, $V_o = 1\text{ V}$, TON = 2.49 k Ω , or 14 k Ω , Note 13 ;		91.5		
		$V_{in} = 12\text{ V}$, $V_o = 1\text{ V}$, TON = 3.48 k Ω , or 16.2 k Ω , Note 13		77		

Electrical specifications

Parameter	Symbol	Conditions	Min	Typ	Max	Unit
On Time	T_{on}	Vin=12 V, Vo=1 V, TON= 4.53 kΩ, or 18.7 kΩ, Note 13		66.5		ns
		Vin=12 V, Vo=1 V, TON= 5.76 kΩ, or 21.5 kΩ, Note 13		58.5		
		Vin=12 V, Vo=1 V, TON= 7.32 kΩ, or 24.9 kΩ, Note 13		52		
		Vin=12V , Vo=1 V, TON= 8.87kΩ, or 28.7kΩ, Note 13		47		
		Vin=12V, Vo=1.0V, TON = Floating, Note 13		114		
Minimum On-Time	$T_{on (Min)}$	Vin=12 V, Vo=0 V		23	32	ns
Minimum Off-Time	$T_{off (Min)}$	Tj=25 °C, VFB=0 V		270	360	ns
VCC LDO Output						
Output Voltage	VCC	5.5 V ≤ Vin ≤ 17 V, when Icc =50 mA, Cload = 2.2 μF	4.7	5.0	5.3	V
VCC Dropout	VCC_drop	Vin = 4.3 V, Icc=50 mA, Cload=2.2 μF			300	mV
Short Circuit Current	Ishort	5.5 V ≤ Vin ≤ 17 V		90		mA
Under Voltage Lockout						
VCC-Start Threshold	Vcc_UVLO_Start	VCC Rising Trip Level	3.8	4.0	4.2	V
VCC-Stop Threshold	Vcc_UVLO_Stop	VCC Falling Trip Level	3.6	3.8	4.0	
Enable-Start-Threshold	En_UVLO_Start	ramping up	1.14	1.2	1.36	V
Enable-Stop-Threshold	En_UVLO_Stop	ramping down	0.9	1	1.06	
Input Impedance	REN		500	1000	1500	kΩ
Over Current Limit						
Current Limit Threshold (Valley current)	Ioc	Tj = 25 °C, int LDO, RILIM=24.9 kΩ	33.8	39	45.0	A
		Tj = 25 °C, int LDO, RILIM=21.5 kΩ	28.2	32.5	37.4	
		Tj = 25 °C, int LDO, RILIM=16.2 kΩ	22.5	26	29.9	
		Tj = 25 °C, int LDO, RILIM=12.1 kΩ	15.0	19.5	23.0	
Over Voltage Protection						
OVP Trip Threshold	OVP_Vth	FB Rising	115	121	125	% Vref
		FB Falling, OVP hysteresis	110	115	120	
OVP Protection Delay	OVP_Tdly			7		μs
Hiccup Blanking Time	Tblk_Hiccup	Unlatched OVP		20		ms
Under Voltage Protection						
UVP Trip Threshold	UVP_Vth	FB Falling	65	70	75	% Vref
UVP Protection Delay	UVP_Tdly			5		μs
Hiccup Blanking Time	Tblk_Hiccup			20		ms
Power Good						
PGood Turn on Threshold	VPG(upper)	FB Rising	85	91	95	% Vref

Electrical specifications

Parameter	Symbol	Conditions	Min	Typ	Max	Unit
PGood Turn off Threshold	VPG(lower)	FB Falling	80	84	90	% Vref
PGood Sink Current	I _{PG}	PG = 0.5 V, En = 2 V	2.5	5		mA
PGood Voltage Low	V _{PG(low)}	Vin = VCC = 0 V, Rpull-up = 50 kΩ to 3.3 V		0.3	0.5	V
PGood Turn on Delay	V _{PG(on)_Dly}	FB Rising, see VPG(upper)		2.5		ms
PGood Comparator Delay	V _{PG(comp)_Dly}	VFB < VPG(lower) or VFB > VPG(upper)	1	2	3.5	μs
PGood Open Drain Leakage Current		PG = 3.3 V			1	μA
Thermal Shutdown						
Thermal Shutdown		Note 11		140		°C
Hysteresis		Note 11		20		

Note:

11. *Guaranteed by construction and not tested in production*
12. *Cold temperature performance is guaranteed via correlation using statistical quality control. Not tested in production.*
13. *The Ton is trimmed so that the target switching frequency is achieved at around 10A load current using EVAL_3887_1Vout demo board.*

Typical efficiency and power loss curves

8 Typical efficiency and power loss curves

8.1 $P_{Vin} = V_{in} = 12\text{ V}$, $F_{sw} = 600\text{ kHz}$

$P_{Vin} = V_{in} = 12\text{ V}$, $V_{CC} = \text{Internal LDO}$, $I_o = 0\text{ A}-30\text{ A}$, $F_{sw} = 600\text{ kHz}$, Room Temperature, No Air Flow. Note that the efficiency and power loss curves include the losses of IR3887, the inductor losses, the losses of the input and output capacitors, and PCB trace losses. The table below shows the inductors used for each of the output voltages in the efficiency measurement.

Table 1 Inductors for $P_{Vin}=V_{in}=12\text{ V}$, $F_s = 600\text{ kHz}$

Vout (V)	Lout (nH)	P/N	DCR (mΩ)	Size (mm)
1.0	150	HCB138380D-151 (Delta)	0.15	12.4 x 8.3 x 8
1.2	150	HCB138380D-151 (Delta)	0.15	12.4 x 8.3 x 8
1.8	220	FP1008R5-R220-R (Cooper)	0.17	10.8 x 8 x 8
3.3	350	HCBD101195-351(Delta)	0.35	10.1 x 11.4 x 9.5
5	450	HCBD101195-451(Delta)	0.35	10.1 x 11.4 x 9.5

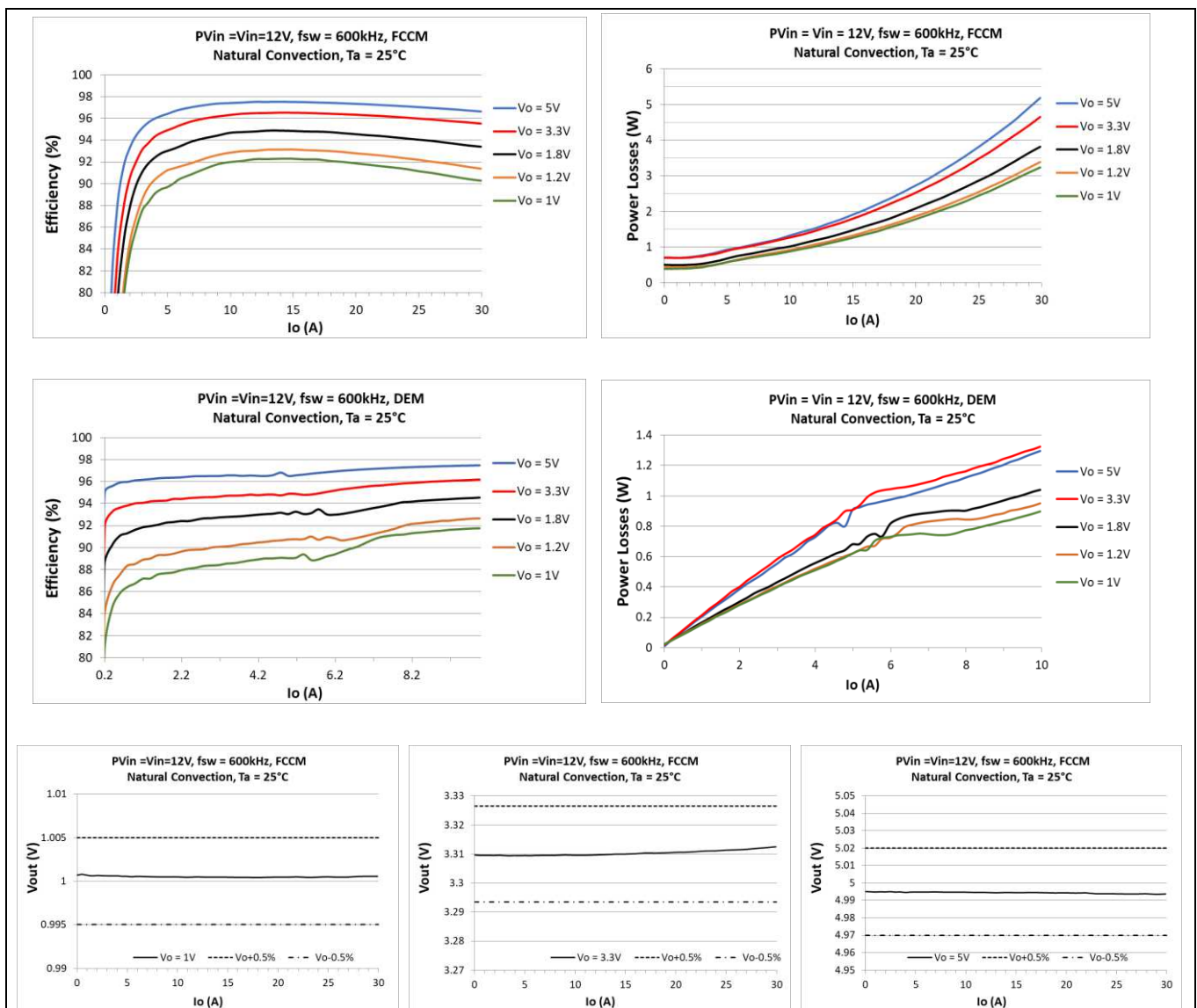

Typical efficiency and power loss curves

8.2 $P_{Vin} = V_{in} = 12\text{ V}$, $F_{sw} = 800\text{ kHz}$

$P_{Vin} = V_{in} = 12\text{ V}$, $V_{CC} = \text{Internal LDO}$, $I_o = 0\text{ A}-30\text{ A}$, $F_{sw} = 800\text{ kHz}$, Room Temperature, No Air Flow. Note that the efficiency and power loss curves include the losses of IR3887, the inductor losses, the losses of the input and output capacitors, and PCB trace losses. The table below shows the inductors used for each of the output voltages in the efficiency measurement.

Table 2 Inductors for $P_{Vin}=V_{in}=12\text{ V}$, $F_{sw} = 800\text{ kHz}$

Vout (V)	Lout (nH)	P/N	DCR (mΩ)	Size (mm)
1.0	150	HCB138380D-151 (Delta)	0.15	12.4 x 8.3 x 8
1.2	150	HCB138380D-151 (Delta)	0.15	12.4 x 8.3 x 8
1.8	150	HCB138380D-151 (Delta)	0.15	12.4 x 8.3 x 8
3.3	350	HCBD101195-351(Delta)	0.35	10.1 x 11.4 x 9.5

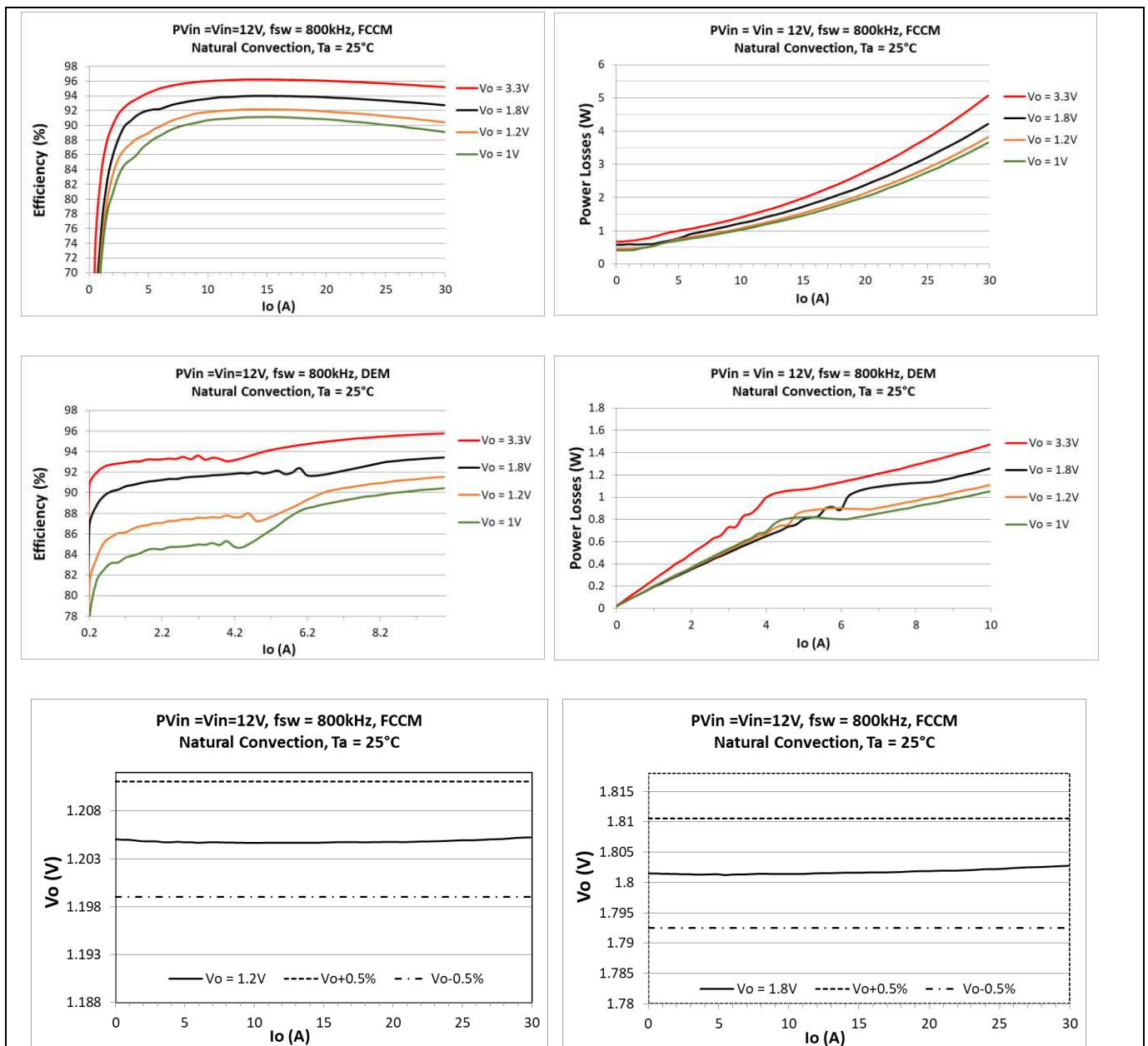

Typical efficiency and power loss curves

8.3 $P_{Vin} = V_{in} = 12\text{ V}$, $F_{sw} = 1000\text{ kHz}$

$P_{Vin} = V_{in} = 12\text{ V}$, $V_{CC} = \text{Internal LDO}$, $I_o = 0\text{ A}-30\text{ A}$, $F_{sw} = 1000\text{ kHz}$, Room Temperature, No Air Flow. Note that the efficiency and power loss curves include the losses of IR3887, the inductor losses, the losses of the input and output capacitors, and PCB trace losses. The table below shows the inductors used for each of the output voltages in the efficiency measurement.

Table 3 Inductors for $P_{Vin}=V_{in}=12\text{ V}$, $F_{sw} = 1000\text{ kHz}$

Vout (V)	Lout (nH)	P/N	DCR (mΩ)	Size (mm)
1.0	100	AH3740A-100K (ITG)	0.145	6.4 x 9.5 x 10
1.2	100	AH3740A-100K (ITG)	0.145	6.4 x 9.5 x 10
1.8	120	AH3740A-120K (ITG)	0.145	6.4 x 9.5 x 10

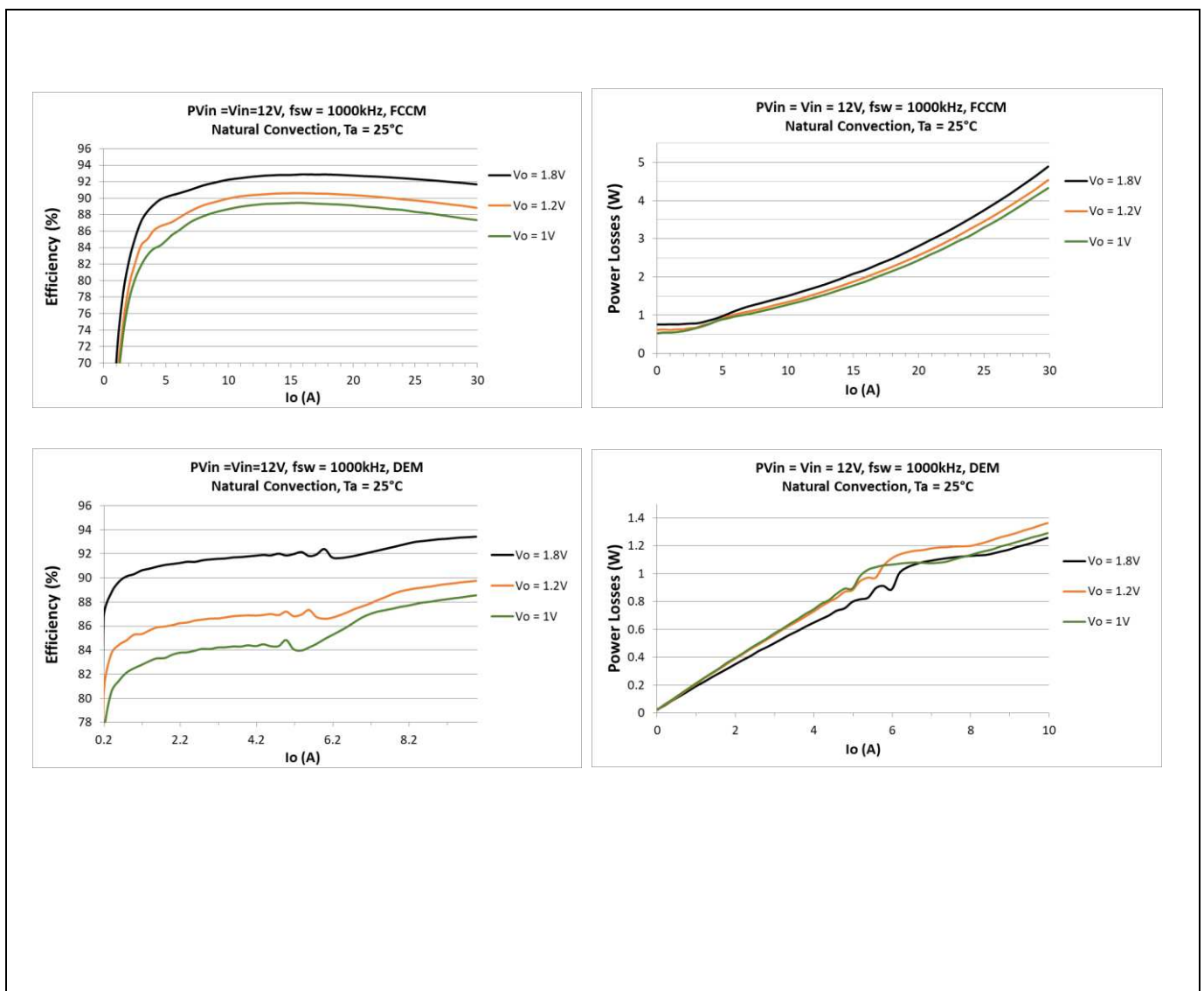

Typical efficiency and power loss curves

8.4 $P_{Vin} = V_{in} = V_{CC} = 5\text{ V}$, $F_{sw} = 600\text{ kHz}$

$P_{Vin} = V_{in} = V_{CC} = 5.0\text{ V}$, $I_o = 0\text{ A} - 30\text{ A}$, $F_{sw} = 600\text{ kHz}$, Room Temperature, No Air Flow. Note that the efficiency and power loss curves include the losses of IR3887, the inductor losses, the losses of the input and output capacitors and PCB trace losses. The table below shows the inductors used for each of the output voltages in the efficiency measurement.

Table 4 Inductors for $P_{Vin}=V_{in}=V_{CC}=5\text{ V}$, $F_{sw} = 600\text{ kHz}$

Vout (V)	Lout (nH)	P/N	DCR (mΩ)	Size (mm)
1.0	120	AH3740A-120K (ITG)	0.145	6.4 x 9.5 x 10
1.2	120	AH3740A-120K (ITG)	0.145	6.4 x 9.5 x 10
1.8	150	AH3740A-150K (ITG)	0.145	6.4 x 9.5 x 10
3.3	150	AH3740A-150K (ITG)	0.145	6.4 x 9.5 x 10

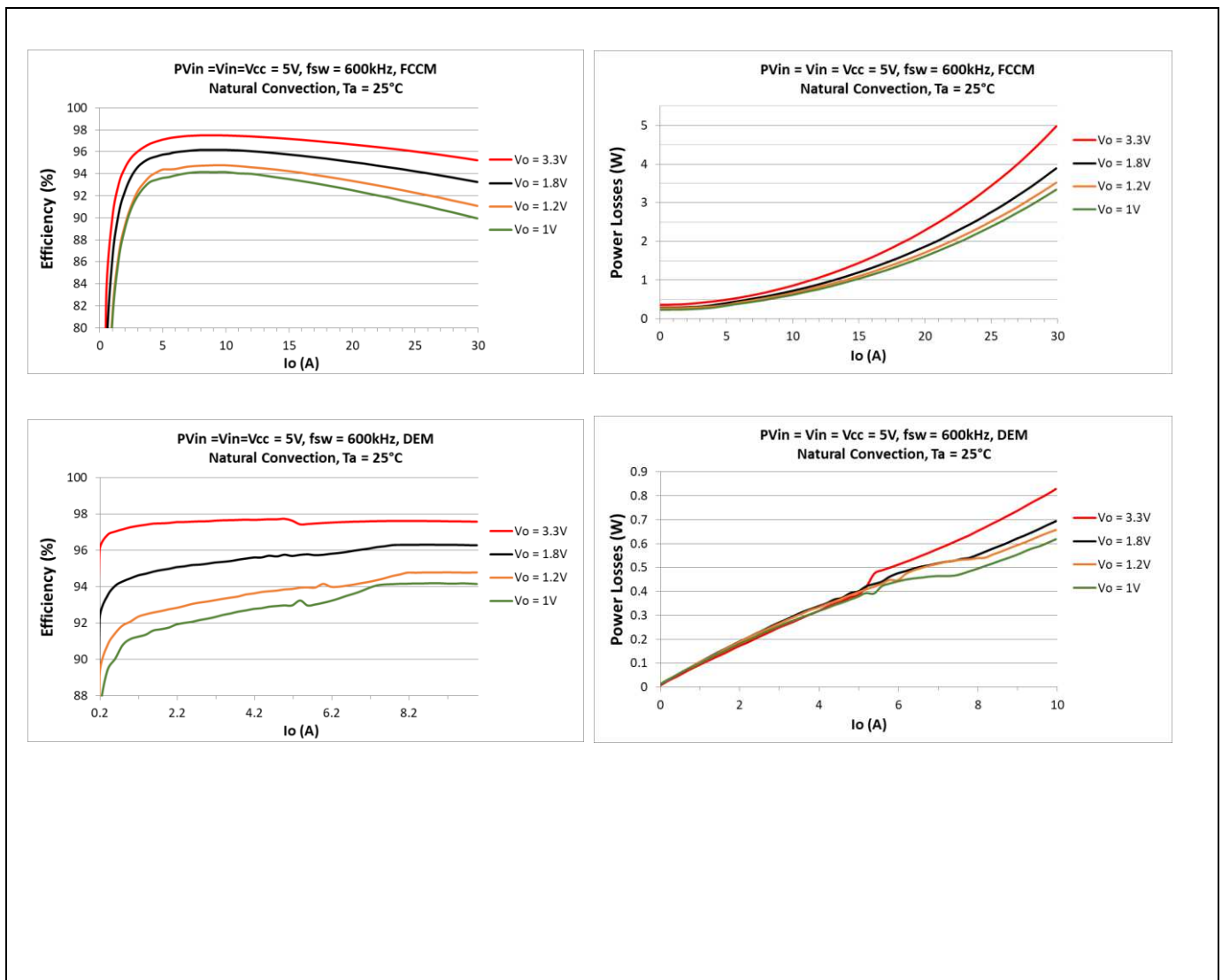

9 Thermal De-rating curves

Measurement is done on Evaluation board of EVAL_3887. PCB is a 6-layer board with 1.5 oz Copper for top and bottom layer and 2 oz Copper for the inner layers, FR4 material, size 3.0”x3.75”.

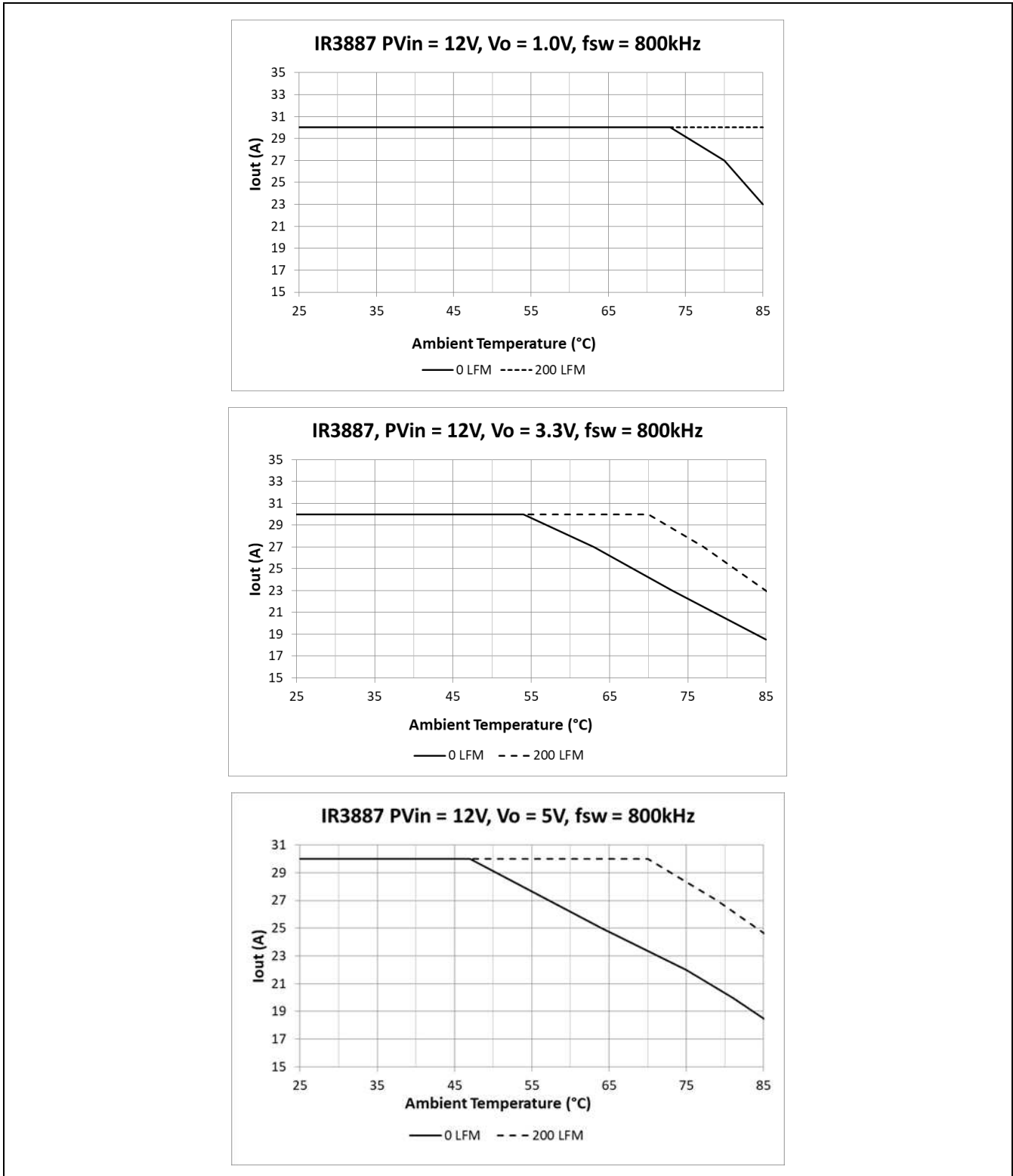

Figure 4 Thermal de-rating curves, PVin = 12 V, Vout=1.0 V/3.3 V/5 V, fsw = 800 kHz, VCC = Internal LDO

10 R_{DS(on)} of MOSFET Over Temperature

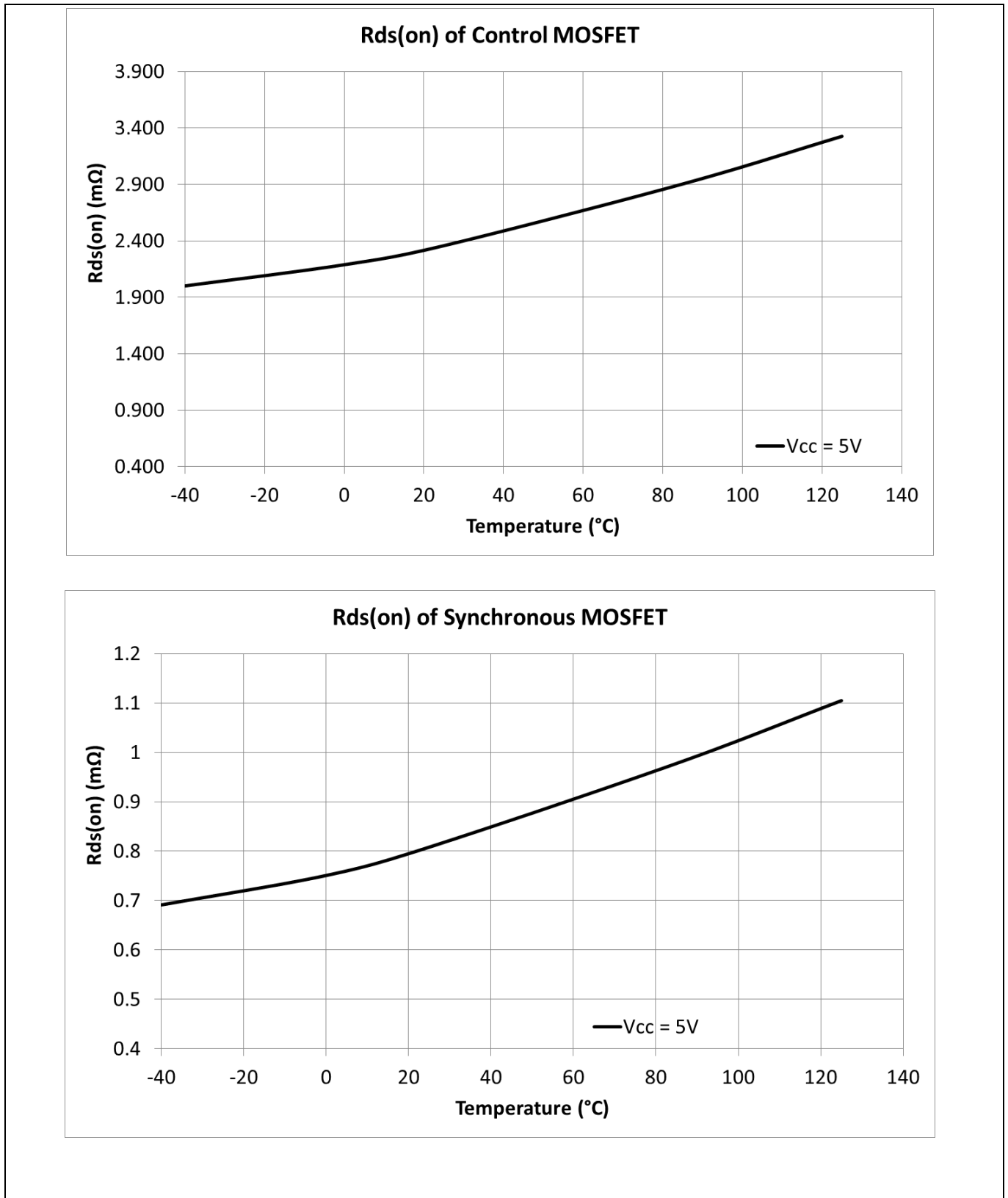

Figure 5 R_{DS(on)} of MOSFETs over Junction Temperature

11 Typical operating characteristics (-40 °C ≤ T_j ≤ +125 °C)

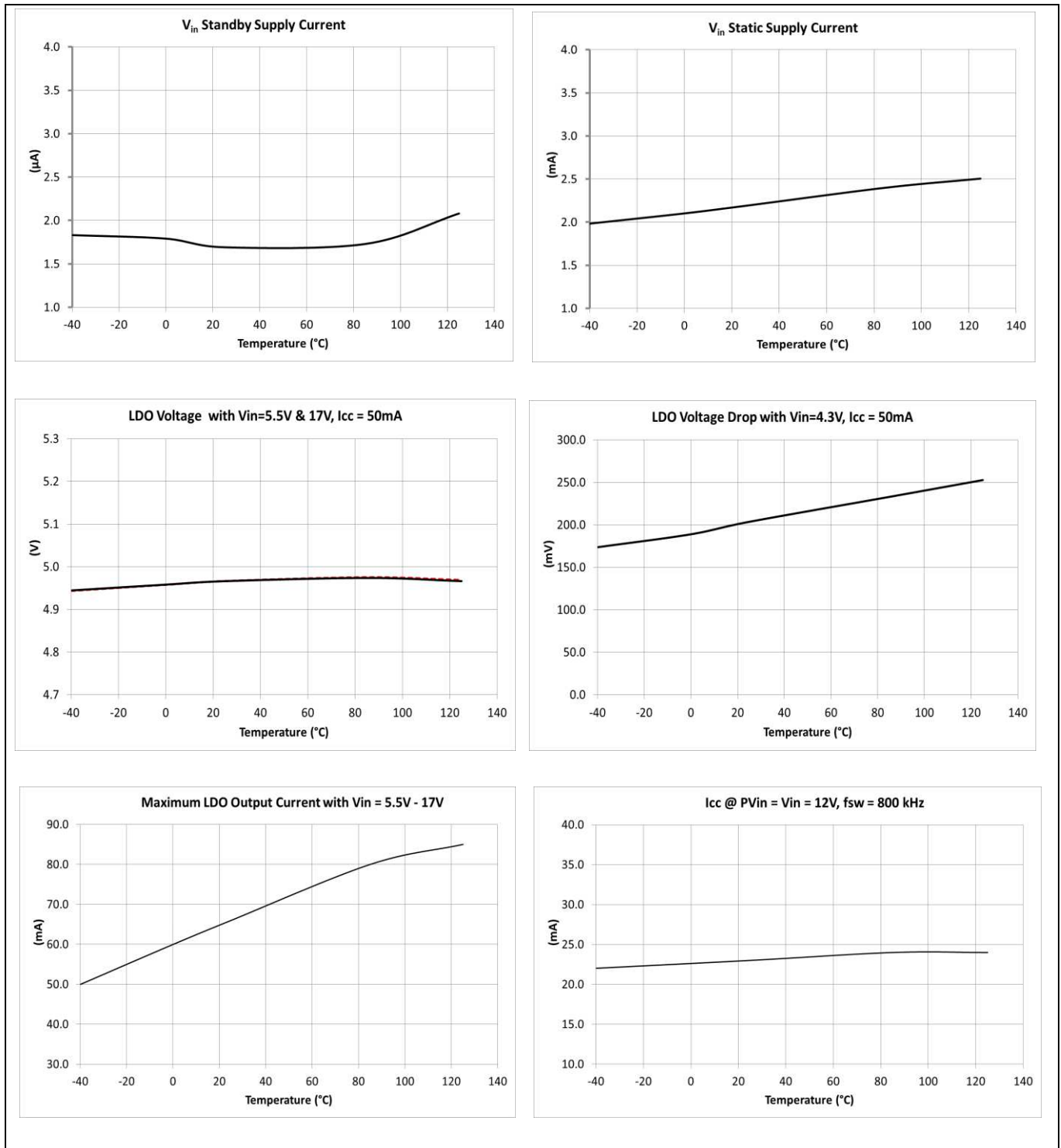

Figure 6 Typical operating characteristics (set 1 of 3)

IR3887 OptiMOS™ IPOL
30 A single-voltage synchronous Buck regulator
Typical operating characteristics (-40 C ≤ Tj ≤ +125 C)

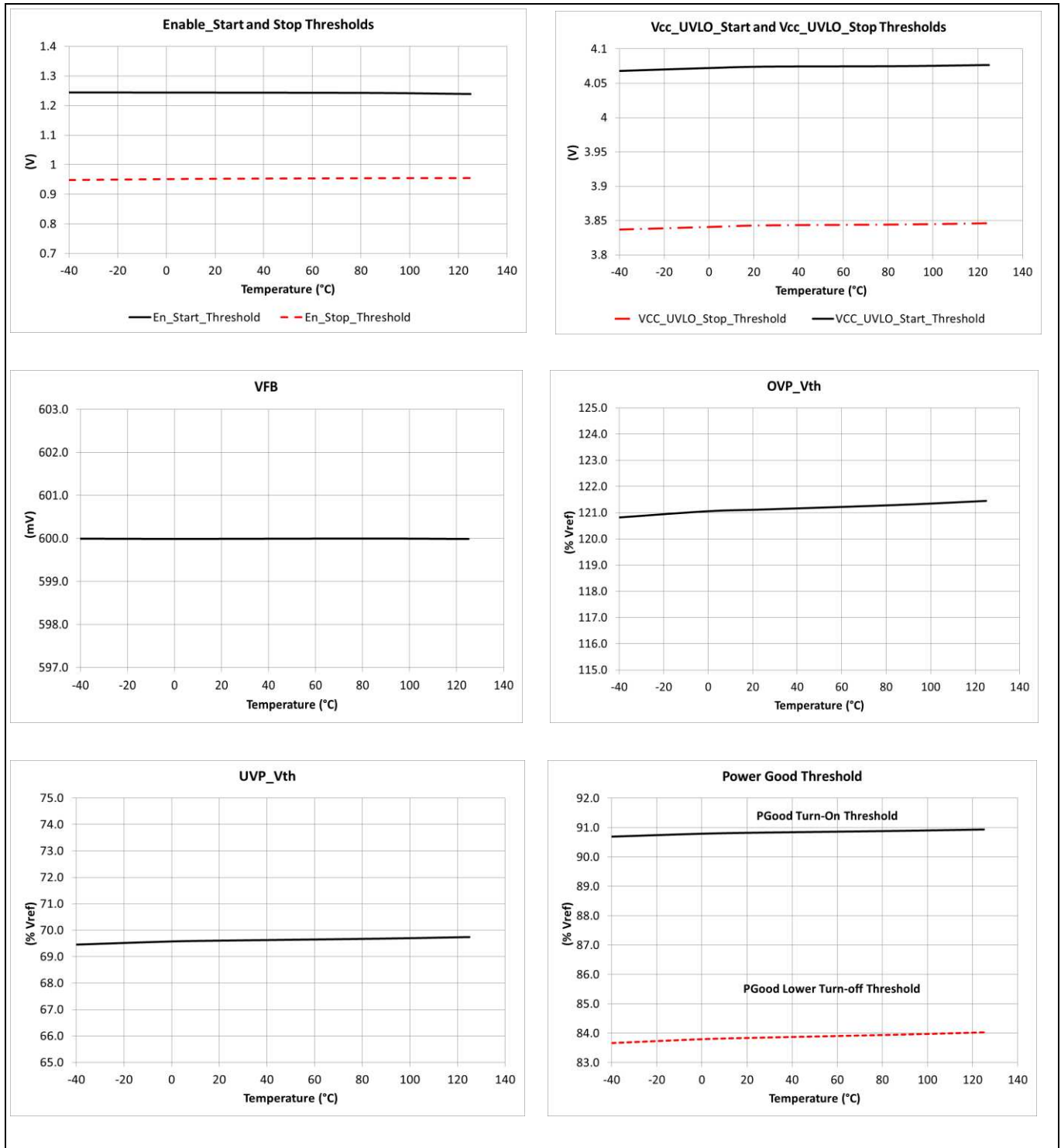

Figure 7 Typical operating characteristics (set 2 of 3)

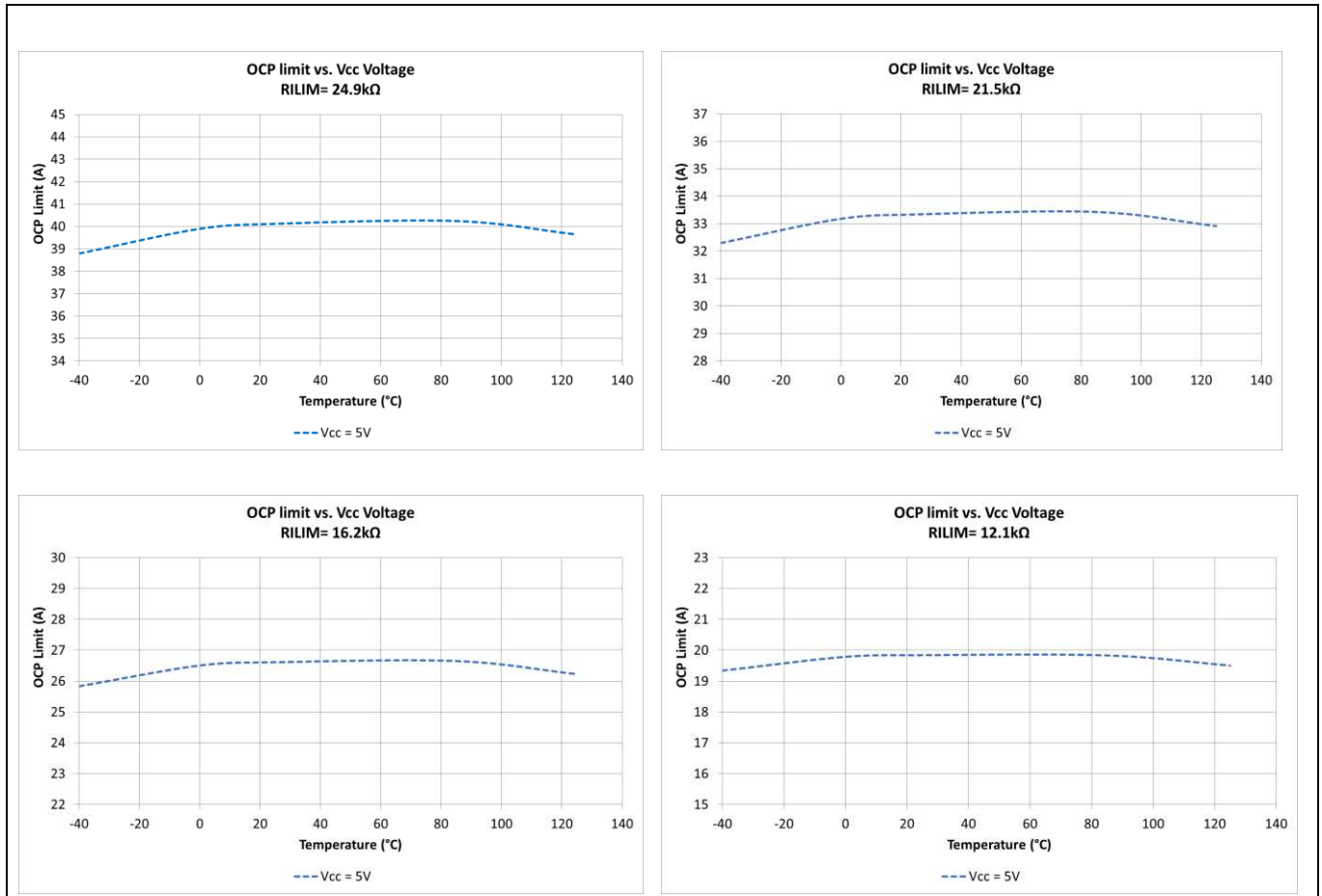

Figure 8 Typical operating characteristics (set 3 of 3)

12 Theory of operation

12.1 Fast Constant On-Time Control

The IR3887 features a proprietary Fast Constant On-Time (COT) Control, which can provide fast load transient response, good output regulation and minimize the design effort. Fast COT control compares the output voltage, V_o , to a floor voltage combined with an internal ramp signal. When V_{out} drops below that signal, a PWM signal is initiated to turn on the high-side FET for a fixed on-time. The floor voltage is generated from an internal compensated error amplifier, which compares the V_{out} with a reference voltage. Compared to the traditional COT control, Fast COT control significantly improves the V_{out} regulation.

12.2 Enable

En pin controls the on/off of the IR3887. An internal Under Voltage Lock-Out (UVLO) circuit monitors the En voltage. When the En voltage is above an internal threshold, the internal LDO starts to ramp up. When the VCC/LDO voltage rises above the VCC_UVLO_Start threshold, the soft-start sequence starts. The En pin can be configured in three ways, as shown in **Figure 9**. With configuration 2, the Enable signal is derived from the PVin voltage by a set of resistive divider, R_{EN1} and R_{EN2} . By selecting different divider ratios, users can program a UVLO threshold voltage for the bus voltage. This is a very desirable feature because it prevents the IR3887 from operating until PVin is higher than a desired voltage level. For some space constrained designs, the En pin can be directly connected to PVin without using the external resistor dividers, as shown in Configuration 3. The En pin should not be left floating. A pull down resistor in the range of tens of kilohms is recommended. **Figure 10** illustrates the corresponding start-up sequences with three En configurations.

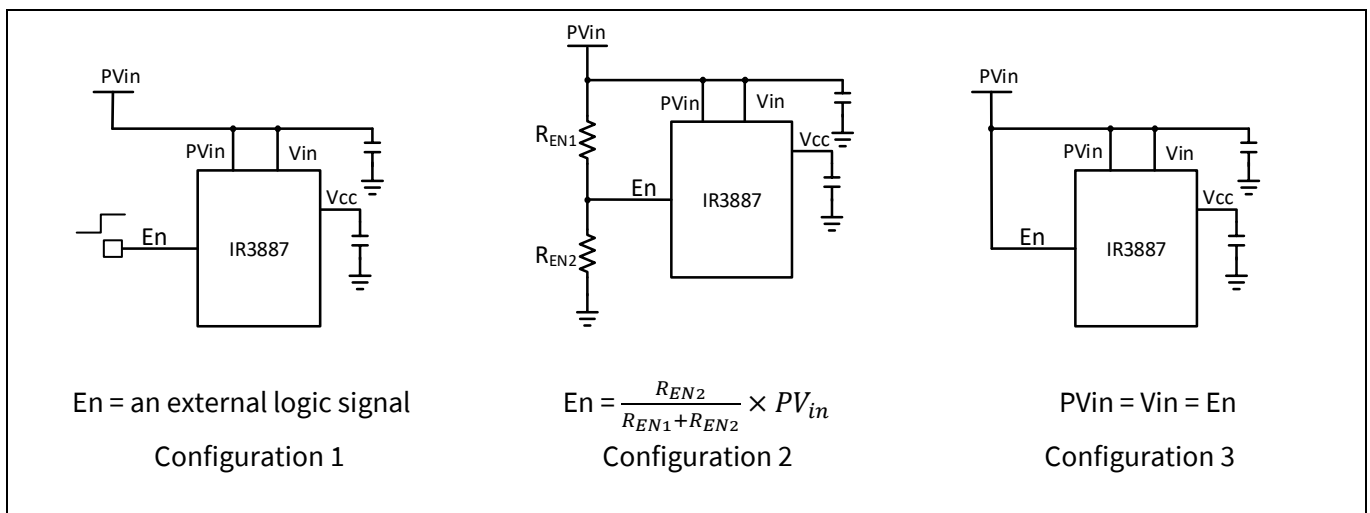

Figure 9 Enable Configurations

Theory of operation

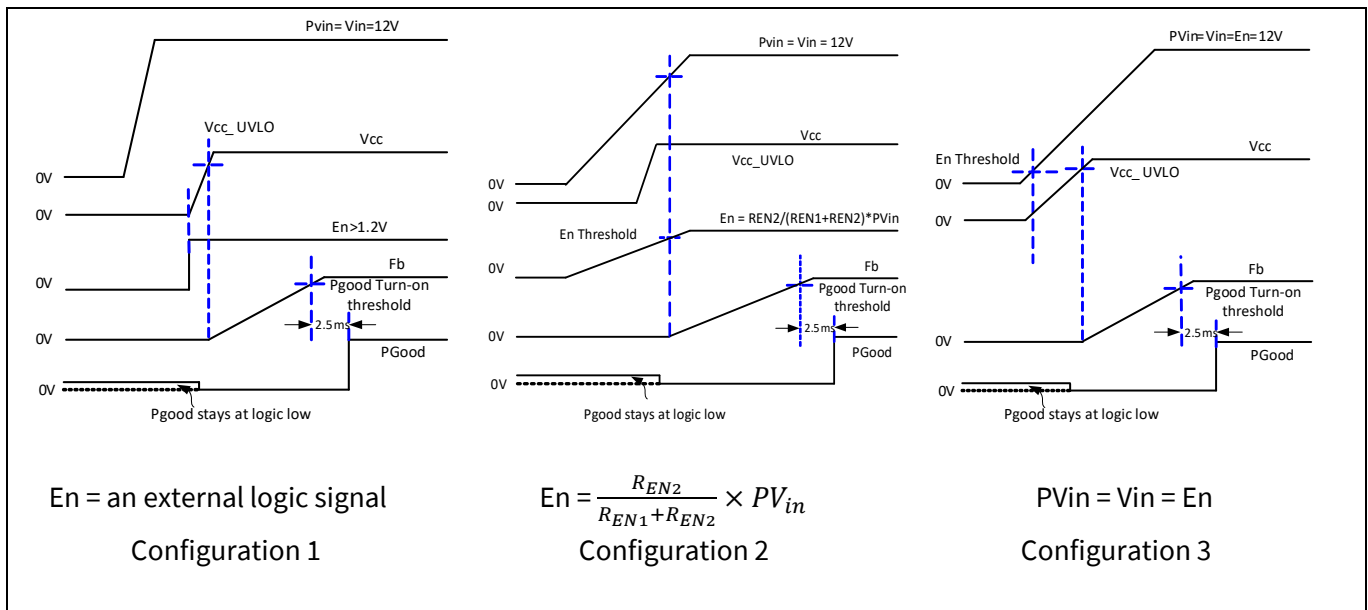

Figure 10 Start-up sequence

12.3 FCCM and DEM Operation

The IR3887 offers two operation modes: Forced Continuous Conduction (FCCM) and Diode Emulation Mode (DEM). With FCCM, the IR3887 always operates as a synchronous buck converter with a pseudo constant switching frequency and therefore achieves small output voltage ripples. In DEM, the synchronous FET is turned off when the inductor current is close to zero, which reduces the switching frequency and improves the efficiency at light load. At heavy load, both FCCM and DEM operate in the same way. The operation mode can be selected with TON/MODE pin, as shown in [Table 5](#). It should be noted that the selection of the operation mode cannot be changed on the fly. To load a new TON/MODE configuration, En or VCC voltage needs to be cycled.

12.4 Pseudo Constant Switching Frequency

The IR3887 offers eight programmable switching frequencies, f_{sw} , from 600 kHz to 2 MHz, by connecting an external resistor from Ton/Mode pin to the ground. Based on the selected f_{sw} , the IR3887 generates the corresponding on-time of the Control FET for a given PV_{in} and V_o , as shown by the formula below.

$$T_{on} = \frac{V_o}{PV_{in}} \times \frac{1}{f_{sw}}$$

Where f_{sw} is the desired switching frequency. During the operation, the IR3887 monitors PV_{in} and V_o , and can automatically adjust the on-time to maintain the pre-selected f_{sw} . With the increase of the load, the switching frequency can increase to compensate for the power losses. Therefore, the IR3887 has a pseudo constant switching frequency.

Table 5 lists the resistors for TON/MODE pin. In this table, E96 resistors with $\pm 1\%$ tolerance are used. If E12 resistor values are preferred, please refer to the Section [12.15](#). To load a new TON/MODE configuration, En or VCC voltage needs to be cycled.

Table 5 Configuration Resistors for TON/MODE Pin

TON/MODE Resistor (kΩ) ±1% Tolerance	Freq (kHz)	Mode
0	600	FCCM
1.5	800	
2.49	1000	
3.48	1200	
4.53	1400	
5.76	1600	
7.32	1800	
8.87	2000	
10.5	600	
12.1	800	
14	1000	
16.2	1200	
18.7	1400	
21.5	1600	
24.9	1800	
28.7	2000	
Ton = Floating	800	FCCM

12.5 Soft-start

The IR3887 has an internal digital soft-start to control the output voltage rise and to limit the current surge at the start-up. To ensure a correct start-up, the soft-start sequence initiates when the EN and VCC voltages rise above their respective thresholds. The internal soft-start signal linearly rises from 0 V to 0.6 V in a defined time duration. The soft-start time does not change with the output voltage. During the soft-start, the IR3887 operates in DEM until 1ms after the output voltage ramps above the PGood turn-on threshold. The IR3887 has four soft-start time options selected by placing a resistor from SS/Latch pin to the ground. [Table 6](#) lists the resistor values and its corresponding soft-start time. In this table, E96 resistors with ±1% tolerance are used. If E12 resistor values are preferred, please refer to the Section [12.15](#). For each soft-start time, there are two resistor options available. Please note that SS/Latch pin is a multi-function pin, which is also used to select different responses for Over Voltage Protection (OVP). Please note that to load a new SS/Latch selection, En or VCC voltage needs to be cycled.

Theory of operation

Table 6 Configuration Resistor for SS/Latch Pin

SS/Latch Resistor (kΩ) ±1% Tolerance	Soft-start Time (ms)	OVP	
0	1	Latch	
4.53			
1.5	2		
5.76			
2.49	4		
7.32			
3.48	8		
8.87			
10.5	1		No Latch
18.7			
12.1	2		
21.5			
14	4		
24.9			
16.2	8		
28.7			
SS/Latch = Floating	4	Latch	

12.6 Pre-bias Start-up

The IR3887 is able to start up into a pre-charged output without causing oscillations and disturbances of the output voltage. When IR3887 starts up with a pre-biased output voltage, both control FET and Synch FET are kept off till the internal soft-start signal exceeds the FB voltage.

12.7 Internal Low - Dropout (LDO) Regulator

The IR3887 has an integrated low-dropout LDO regulator, providing the bias voltage for the internal circuitry. To minimize the standby current, the internal LDO is disabled when the En voltage is pulled low. VIN pin is the input of the LDO. When using the internal LDO for a single rail operation, VIN pin should be connected to PVIN pin. To save the power losses on the LDO, an external bias voltage can be used by connecting VIN pin to the VCC/LDO pin. **Figure 11** illustrates the configuration of VCC/LDO, and VIN pin.

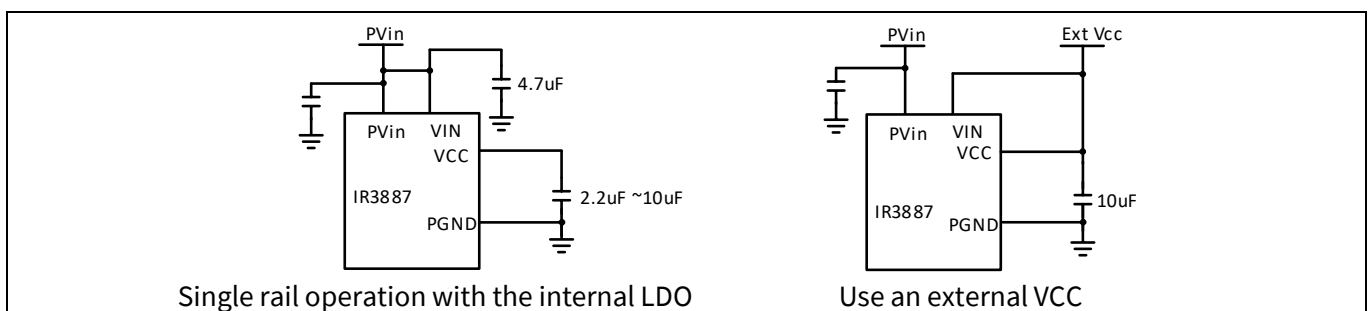

Figure 11 Configuration of Using the internal LDO or an external VCC.

Theory of operation

Section 7.1 specified the recommended operating voltage range of V_{in} and VCC under different configurations. Following design guidelines are recommended when configuring the VCC/LDO.

- Place a bypass capacitor to minimize the disturbance on the VCC pin. For a single rail operation using the internal LDO, a 4.7 μF low ESR ceramic capacitor must be used between VIN pin and PGND and a 2.2 μF ~10 μF low ESR ceramic capacitor is required to be placed close to the VCC/LDO with reference to PGND. 10 μF MLCC is recommended for VCC bypass capacitor when VIN is below 5.5 V. When using an external VCC bias voltage, a 10 μF ceramic capacitor can be shared with VIN, and VCC/LDO pin.
- When using the internal LDO with $5.5\text{ V} \leq V_{in} \leq 17\text{ V}$, it is recommended to check the required VCC bias current for the operation above 1.6 MHz, to ensure that it does not exceed the LDO output current capability as shown in Figure 6. With the increase of f_{sw} , the resulting I_{CC} is also increased mainly due to the increase of the gate charge that is proportional to f_{sw} . In Figure 6, the typical I_{CC} at $PV_{in} = V_{in} = 12\text{ V}$ and $f_{sw} = 800\text{ kHz}$ has been provided, which can be used to estimate the I_{CC} at other f_{sw} .
- For applications using the internal LDO with $4.3\text{ V} \leq V_{in} \leq 5.4\text{ V}$, the LDO can be in the dropout mode. It is important to ensure that the LDO voltage does not fall below the VCC UVLO threshold voltage. At $V_{in} = 4.3\text{ V}$, I_{CC} must not exceed 50 mA under all operating conditions such as during a step-up load transient, in which the control loop may require the increase of f_{sw} . OCP limits can be reduced due to the lower VCC voltage.

12.8 Over Current Protection (OCP)

The IR3887 offers cycle-by-cycle OCP response with four selectable current limits, which is set by the resistance between ILIM pin and GND. The selected OCP limit bank is loaded to the IC during the power up and cannot be changed on the fly. To change the OCP limit, users must cycle EN signal or VCC voltage. Cycle-by-cycle OCP response allows the IR3887 to fulfill a brief high current demand, such as a high inrush current during the start-up. The detailed operation is explained as follows.

The OCP is activated when EN voltage is above its threshold. The OCP circuitry monitors the current of the Synchronous MOSFET through its $R_{ds(on)}$. When a new PWM pulse is requested by the control loop, if the current of Synchronous MOSFET exceeds the selected OCP limit, the IR3887 skips the PWM pulse and extends the on-time of Synchronous MOSFET till the current drops below the OCP limit. The OCP operation is also illustrated in Figure 12. As can be seen, during OCP events, the valley of the inductor current is regulated around the OCP limit. But during the first switching cycle when the OCP is tripped, the valley of the inductor current can drop slightly below the OCP limit. It should be noted that OCP events do not pull the PGood signal low unless the V_o drops below the PGood turn-off threshold. If the OCP event persists, the output voltage can eventually drop below the Under Voltage Protection (UVP) threshold and trigger UVP. Then the IR3887 enters a hiccup mode.

The OCP limits are thermally compensated. Please refer to the typical performance of OCP limits in Figure 7 and Figure 8. The OCP limits specified in the Section 7.2 refer to the valley of the inductor current when OCP is tripped. Therefore, the corresponding output DC current can be calculated as follows:

$$I_{out_OCP} = I_{LIM} + \frac{\Delta i_L}{2}$$

Where: I_{out_OCP} = Output DC current when OCP is tripped. I_{LIM} = OCP limit specified in the Section 7.2, which is the valley of inductor current. Δi_L = Peak-peak inductor ripple current.

To avoid the inductor saturation during OCP events, the following criterion is recommended for the inductor saturation current rating.

$$I_{sat} \geq I_{LIM_max} + \Delta i_L$$

Where: I_{sat} is the inductor saturation current and I_{LIM_max} is the maximum spec of the OCP limit.

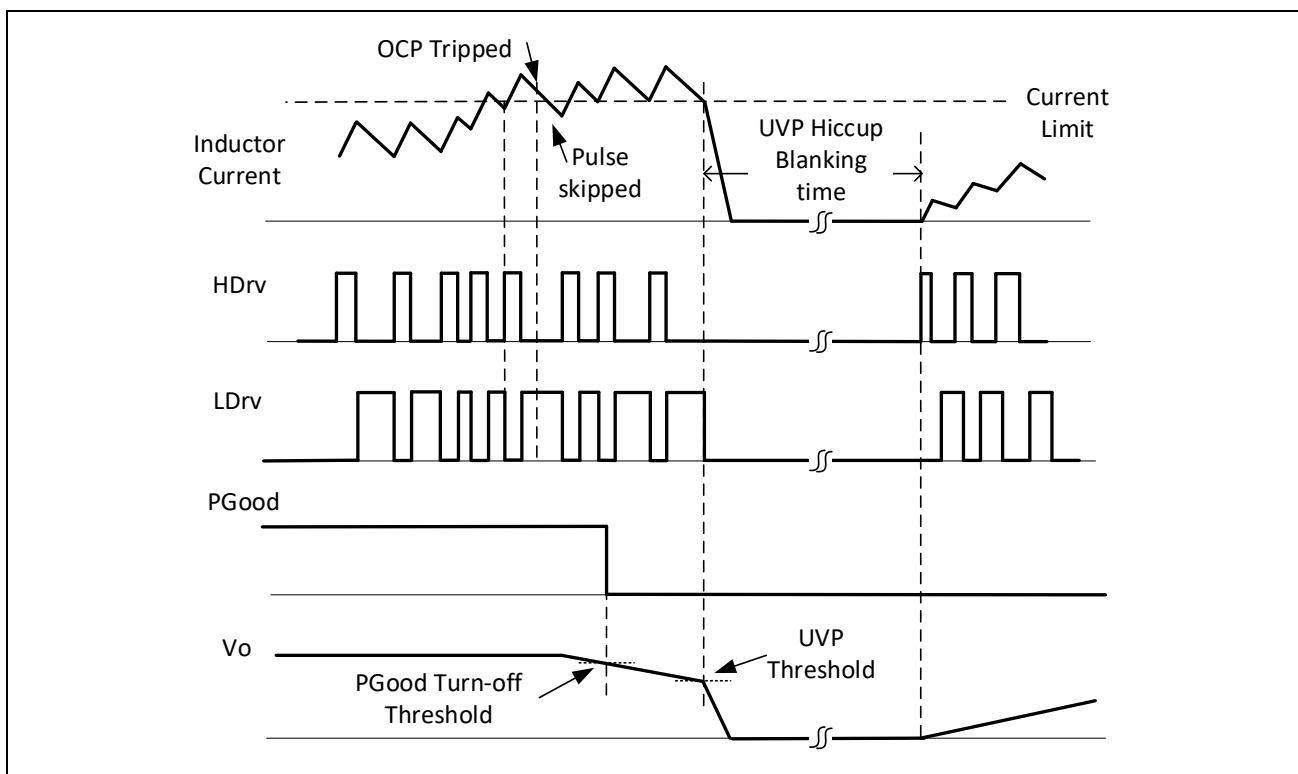

Figure 12 Cycle-by-cycle OCP response

12.9 Under Voltage Protection (UVP)

Under Voltage Protection (UVP) provides additional protection during OCP fault or other faults. UVP is activated when the soft-start voltage rises above 100 mV. UVP circuitry monitors the FB voltage. When it is below the UVP threshold for 5 μ s (typical), an under voltage trip signal asserts and both Control MOSFET and Synchronous MOSFET are turned off. The IR3887 enters a hiccup mode with a blanking time of 20 ms, during which Control MOSFET and Synchronous MOSFET remain off. After the completion of blanking time, the IR3887 attempts to recover to the nominal output voltage with a soft-start, as shown in [Figure 12](#). The IR3887 will repeat hiccup mode and attempt to recover until UVP condition is removed.

12.10 Over Voltage Protection (OVP)

Over Voltage Protection (OVP) is achieved by comparing the FB voltage to an OVP threshold voltage. When the FB voltage exceeds the OVP threshold, an over voltage trip signal asserts after 7 μ s (typical) delay. Control MOSFET is latched off immediately and PGood flags low. Synchronous MOSFET remains on to discharge the output capacitor. When FB voltage drops below around 115% of the reference voltage, Synchronous MOSFET turns off to prevent the complete depletion of the output capacitors. [Figure 13](#) illustrates the OVP operation. The OVP comparator becomes active when the EN signal is above the start threshold.

With SS/Latch pin, two OVP responses can be selected: Latch or No Latch, as shown in [Table 6](#). With a latched OVP response, Control FET remains latched off until either VCC voltage or EN signal is cycled. With an unlatched OVP response, the IR3887 enters a hiccup mode. Control FET remains off for a blanking time of 20ms. After hiccup blanking time expires, the IR3887 will try to restart with a soft-start. The IR3887 can stay in the hiccup mode infinitely if over voltage fault persists.

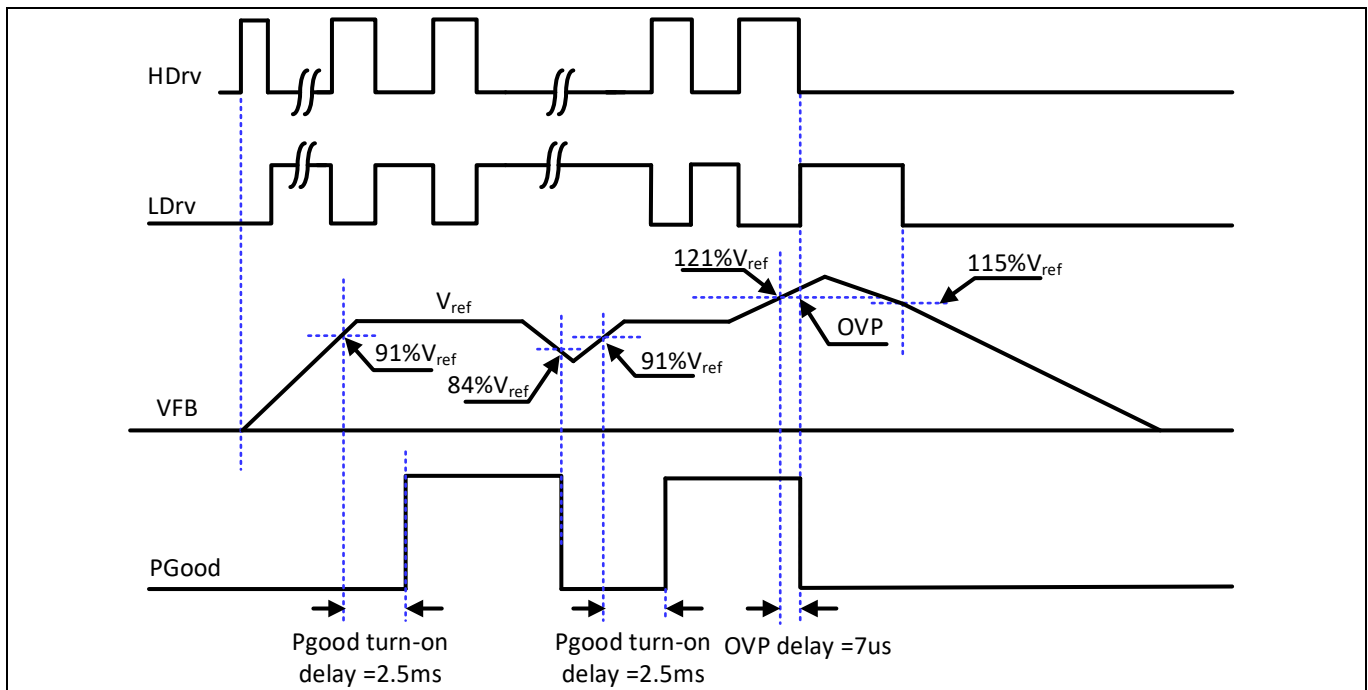

Figure 13 Over voltage protection response and PGood behavior.

12.11 Over Temperature Protection (OTP)

Temperature of the controller is monitored internally. When the temperature exceeds the over temperature threshold, OTP circuitry turns off both Control and Synchronous MOSFETs and resets the internal soft start. Automatic restart is initiated when the sensed temperature drops back into the operating range. The thermal shutdown threshold has a hysteresis of 20 °C.

12.12 Power Good (PGood) Output

The PGood pin is the open drain of an internal NFET, and needs to be externally pulled high through a pull-up resistor. PGood signal is high when three criteria are satisfied.

1. EN signal and VCC voltage are above their respective thresholds.
2. No over voltage and over temperature faults occur.
3. V_o is within the regulation.

In order to detect if V_o is in regulation, PGood comparator continuously monitors the FB voltage. When FB voltage ramps up above the upper threshold, PGood signal is pulled high after 2.5 ms. When FB voltage drops below the lower threshold, PGood signal is pulled low immediately. **Figure 13** illustrates the PGood response.

During the start-up with a pre-biased voltage, PGood signal is held low before the first PWM is generated and is then pulled high with 2.5 ms delay after FB voltage rises above the PGood threshold. IR3887 also integrates an additional PFET in parallel to the PGood NFET, as shown in **Figure 2**. This PFET allows PGood signal to stay at logic low when the VCC voltage is not present, and PGood pin is pulled up by an external bias voltage. Please refer to **Figure 10**. Since PGood PFET has relatively higher on resistance, a 50 kΩ pull-up resistor is needed for a PGood bias voltage of 3.3 V to maintain the PGood signal at logic low when PGood PFET is on.

12.13 Minimum On - Time and Minimum Off - Time

The minimum on-time refers to the shortest time for Control MOSFET to be reliably turned on. The minimum off-time refers to the minimum time duration in which Synchronous FET stays on before a new PWM pulse is generated. The minimum off-time is needed for IR3887 to charge the bootstrap capacitor, and to sense the current of the Synchronous MOSFET for OCP.

For applications requiring a small duty cycle, it is important that the selected switching frequency results in an on-time larger than the maximum spec of the minimum on-time in the Section 7.2. Otherwise the resulting switching frequency may be lower than the desired target. Following formula could be used to check for the minimum on-time requirement.

$$\frac{V_0}{kf_{sw} \times PV_{in}} > \max \text{ spec of } T_{on(\min)}$$

Where f_{sw} is the desired switching frequency. k is the variation of the switching frequency. As a rule of thumb, select $k = 1.25$ to ensure the design margin.

For applications requiring a high duty cycle, it is important to make sure a proper switching frequency is selected so that the resulting off-time is longer than the maximum spec of the minimum off-time in the Section 7.2, which can be calculated as shown below.

$$\frac{PV_{in} - V_0}{kf_{sw} \times PV_{in}} > \max \text{ spec of } T_{off(\min)}$$

Where f_{sw} is the desired switching frequency. k is the variation of the switching frequency. As a rule of thumb, select $k = 1.25$ to ensure the design margin.

The resulting maximum duty cycle is therefore determined by the selected on-time and minimum off-time.

$$D_{max} = \frac{T_{on}}{T_{on} + T_{off(\min)}}$$

12.14 Selection of Feedforward Capacitor and Feedback Resistors

Output voltage can be programmed with an external voltage divider. The FB voltage is compared to an internal reference voltage of 0.6 V. The divider ratio is set to provide 0.6 V at the FB pin when the output is at its desired value. The calculation of the feedback resistor divider is shown below.

$$V_0 = V_{ref} \times \left(1 + \frac{R_{FB1}}{R_{FB2}}\right)$$

Where R_{FB1} and R_{FB2} are the top and bottom feedback resistors.

A small MLCC capacitor, C_{ff} , is preferred in parallel with the top feedback resistor, R_{FB1} , to provide extra phase boost and to improve the transient load response, as shown in Figure 14. Following formula can be used to help select C_{ff} and R_{FB1} . The value of C_{ff} is recommended to be 100 pF or higher to minimize the impact of circuit parasitic capacitance. Where L_o and C_o are the output LC filter of the buck regulator. Table 7 lists the suggested m for some common outputs. C_{ff} and R_{FB1} may be further optimized based on the transient load tests.

$$R_{FB1}C_{ff} = \frac{\sqrt{L_o C_o}}{m \times 4.9}$$

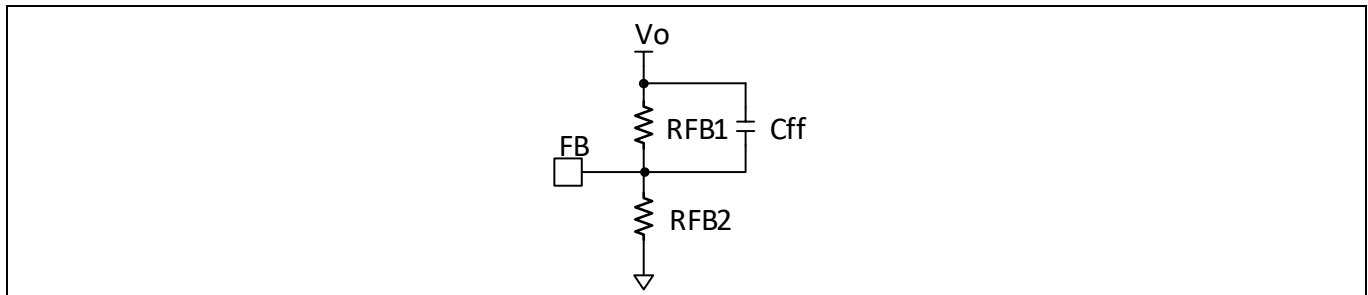

Figure 14 Configuration of feedforward capacitor, Cff.

Table 7 Selection of m

Vo	m
3 V ≤ Vo ≤ 6 V	0.3
1.2 V < Vo < 3 V	0.5
Vo ≤ 1.2 V	0.7

12.15 Resistors for Configuration Pins

To properly configure SS/LATCH pin, MODE/TON pin and ILIM pin, E96 resistors with ±1% tolerance must be used per Table 5, Table 6 and Section 7.2. If E12 resistor values are preferred, the E96 resistors can be replaced with two or three E12 resistors in series, as shown in Table 8. Note that the tolerance of E12 resistors must be ±0.1%.

Table 8 Replacement of E96 configuration resistors with E12 resistors in series

E96 ±1%	E12 ±0.1% (R = R _{S1} + R _{S2} or R _{S1} + R _{S2} + R _{S3})		
	R _{S1} (kΩ)	R _{S2} (kΩ)	R _{S3} (kΩ)
R (kΩ)			
4.53	2.7	1.8	N/A
1.50	1.5	0	N/A
5.76	5.6	0.15	N/A
2.49	1.8	0.68	N/A
7.32	6.8	0.56	N/A
3.45	3.3	0.15	N/A
8.87	8.2	0.68	N/A
10.5	10	0.47	N/A
12.1	12	0.1	N/A
21.5	18	3.3	N/A
14	10	3.9	N/A
24.9	22	2.7	N/A
16.2	15	1.2	N/A
28.7	27	1.8	N/A
21.5	18	3.3	0.18
24.9	22	2.7	0.18

Design example

13 Design example

In this section, an example is used to explain how to design a buck regulator with the IR3887. The application circuit is shown in Figure 15. The design specifications are given below.

- $PV_{in} = 12\text{ V} (\pm 10\%)$
- $V_o = 1.0\text{ V}$
- $I_o = 30\text{ A}$
- V_o ripple voltage = $\pm 1\%$ of V_o
- Load transient response = $\pm 3\%$ of V_o with a step load current = 9 A and slew rate = 30 A/ μ s

13.1 Enabling the IR3887

The IR3887 has a precise Enable threshold voltage, which can be used to implement a UVLO of the input bus voltage by connecting the En pin to PV_{in} with a resistor divider, as shown in Configuration 2 of Figure 9. The Enable feedback resistor, R_{EN1} and R_{EN2} , can be calculated as follows.

$$PV_{in(\min)} \times \frac{R_{EN2}}{R_{EN1} + R_{EN2}} \geq V_{EN(\max)}$$

$$R_{EN2} \geq R_{EN1} \times \frac{V_{EN(\max)}}{PV_{in(\min)} - V_{EN(\max)}}$$

Where $V_{EN(\max)}$ is the maximum spec of the En-start-threshold as defined in Section 7.2. For $PV_{in(\min)} = 10.8\text{ V}$, select $R_{EN1} = 49.9\text{ k}\Omega$ and $R_{EN2} = 7.5\text{ k}\Omega$.

13.2 Programming the Switching Frequency and Operation Mode

The IR3887 has very good efficiency performance and is suitable for high switching frequency operation. In this case, 800 kHz is selected to achieve a good compromise between the efficiency, passive component size and dynamic response. In addition, FCCM operation is selected to ensure a small output ripple voltage over the entire load range. To select 800 kHz and FCCM operation, the TON/MODE pin can be left floating or connect a 1.5 k Ω resistor to GND per Table 5.

13.3 Selecting Input Capacitors

Without input capacitors, the pulse current of Control MOSFET is directly from the input supply power. Due to the impedance on the cable, the pulse current can cause disturbance on the input voltage and potential EMI issues. The input capacitors filter the pulse current, resulting in almost constant current from the input supply. The input capacitors should be selected to tolerate the input pulse current, and to reduce the input voltage ripple. The RMS value of the input ripple current can be expressed by:

$$I_{RMS} = I_o \times \sqrt{D \times (1 - D)}$$

$$D = \frac{V_o}{PV_{in}}$$

Where I_{RMS} is the RMS value of the input capacitor current. I_o is the output current and D is the Duty Cycle. For $I_o = 30\text{ A}$ and $D_{(\max)} = 0.09$, the resulting RMS current flowing into the input capacitor is $I_{rms} = 8.7\text{ A}$.

Design example

To meet the requirement of the input ripple voltage, the minimum input capacitance can be calculated as follows.

$$C_{in(min)} > \frac{I_o \times (1 - D) \times D}{f_{sw} \times (\Delta PV_{in} - ESR \times I_o \times (1 - D))}$$

Where ΔPV_{in} is the maximum allowable peak-to-peak input ripple voltage, and ESR is the equivalent series resistor of the input capacitors. Ceramic capacitors are recommended due to low ESR, ESL and high RMS current capability. For $I_o = 30$ A, $f_{sw} = 800$ kHz, $ESR = 3$ m Ω , and $\Delta PV_{in} = 240$ mV, $C_{in(min)} > 18$ μ F. To account for the de-rating of ceramic capacitors under a bias voltage, 10 x 22 μ F/0805/25V MLCC are used for the input capacitors. In addition, a bulk capacitor is recommended if the input supply is not located close to the voltage regulator.

13.4 Inductor Selection

The inductor is selected based on output power, operating frequency and efficiency requirements. A low inductor value results in a large ripple current, lower efficiency and high output noise, but helps with size reduction and transient load response. Generally, the desired peak-to-peak ripple current in the inductor (Δi) is found between 20% and 50% of the output current.

The inductor saturation current must be higher than the maximum spec of the OCP limit plus the peak-to-peak inductor ripple current. For some core material, inductor saturation current may decrease as the increase of temperature. So it is important to check the inductor saturation current at the maximum operating temperature.

The inductor value for the desired operating ripple current can be determined using the following relation:

$$L = (PV_{in(max)} - V_o) \times \frac{D_{min}}{\Delta i_{L(max)} \times F_{sw}}$$

$$D_{min} = \frac{V_o}{PV_{in(max)}}$$

$$I_{sat} \geq OCP_{max} + \Delta i_{L(max)}$$

Where: $PV_{in(max)}$ = Maximum input voltage; $\Delta i_{L(max)}$ = Maximum peak-to-peak inductor ripple current; OCP_{max} = maximum spec of the OCP limit as defined in Section 7.2; and I_{sat} = inductor saturation current. In this case, select inductor $L = 150$ nH to achieve $\Delta i_{L(max)} = 25\%$ of $I_{o(max)}$. The I_{sat} should be no less than 52 A.

13.5 Output Capacitor Selection

The output capacitor selection is mainly determined by the output voltage ripple and transient requirements.

To satisfy the V_o ripple requirement, C_o should satisfy the following criterion.

$$C_o > \frac{\Delta i_{Lmax}}{8 \times \Delta V_{or} \times f_{sw}}$$

Where ΔV_{or} is the desired peak-to-peak output ripple voltage. For $\Delta i_{Lmax} = 7.5$ A, $\Delta V_{or} = 20$ mV, $f_{sw} = 800$ kHz, C_o must be larger than 59 μ F. The ESR and ESL of the output capacitors, as well as the parasitic resistance or inductance due to PCB layout, can also contribute to the output voltage ripple. It is suggested to use Multi-Layer Ceramic Capacitor (MLCC) for their low ESR, ESL and small size.

To meet the transient response requirements, the output capacitors should also meet the following criterion.

$$C_o > \frac{L \times \Delta I_{o(max)}^2}{2 \times \Delta V_{oL} \times V_o}$$

Design example

Where ΔV_{OL} is the allowable V_o deviation during the load transient. $\Delta I_{o(max)}$ is the maximum step load current. Please note that the impact of ESL, ESR, control loop response, transient load slew rate, and PWM latency is not considered in the calculation shown above. Extra capacitance is usually needed to meet the transient requirements. As a rule of thumb, we can triple the C_o that is calculated above as a starting point, and then optimize the design based on the bench measurement. In this case, to meet the transient load requirement (i.e. $\Delta V_{OL} = 30$ mV, $\Delta I_{o(max)} = 9$ A), select $C_o = \sim 600$ μ F. For more accurate estimation of C_o , simulation tool should be used to aid the design.

13.6 Output Voltage Programming

Output voltage can be programmed with an external voltage divider. The FB voltage is compared to an internal reference voltage of 0.6 V. The divider ratio is set to provide 0.6 V at the FB pin when the output is at its desired value. The calculation of the feedback resistor divider is shown below.

$$V_o = V_{ref} \times \left(1 + \frac{R_{FB1}}{R_{FB2}}\right)$$

Where R_{FB1} and R_{FB2} are the top and bottom feedback resistors. Select $R_{FB1} = 16.2$ k Ω and $R_{FB2} = 24.3$ k Ω , to achieve $V_o = 1$ V.

13.7 Feedforward Capacitor

A small MLCC capacitor, C_{ff} , can be placed in parallel with the top feedback resistor, R_{FB1} , to improve the transient response. Based on Section 12.14, C_{ff} can be selected using the following formula.

$$R_{FB1} C_{ff} = \frac{\sqrt{L_o C_o}}{k \times 4.9}$$

With $L_o = 150$ nH, $C_o = 600$ μ F, $R_{FB1} = 16.2$ k Ω , and $k = 0.7$, $C_{ff} = \sim 170$ pF. Then 220 pF is selected for C_{ff} .

13.8 Bootstrap Capacitor

For most applications, a 0.1 μ F ceramic capacitor is recommended for bootstrap capacitor placed between PHASE and BOOT Pin. For applications requiring PV_{in} equal to or above 14 V, a small resistor of 1~2 Ω should be used in series with the BOOT pin to ensure the maximum SW node spike voltage does not exceed 20 V.

13.9 VIN, and VCC/LDO bypass Capacitor

Please see the recommendation in Section 12.7. A 10 μ F MLCC is selected for VCC/LDO bypass capacitor and a 4.7 μ F MLCC is selected for VIN bypass capacitor.

14 Application Information

14.1 Application Diagram

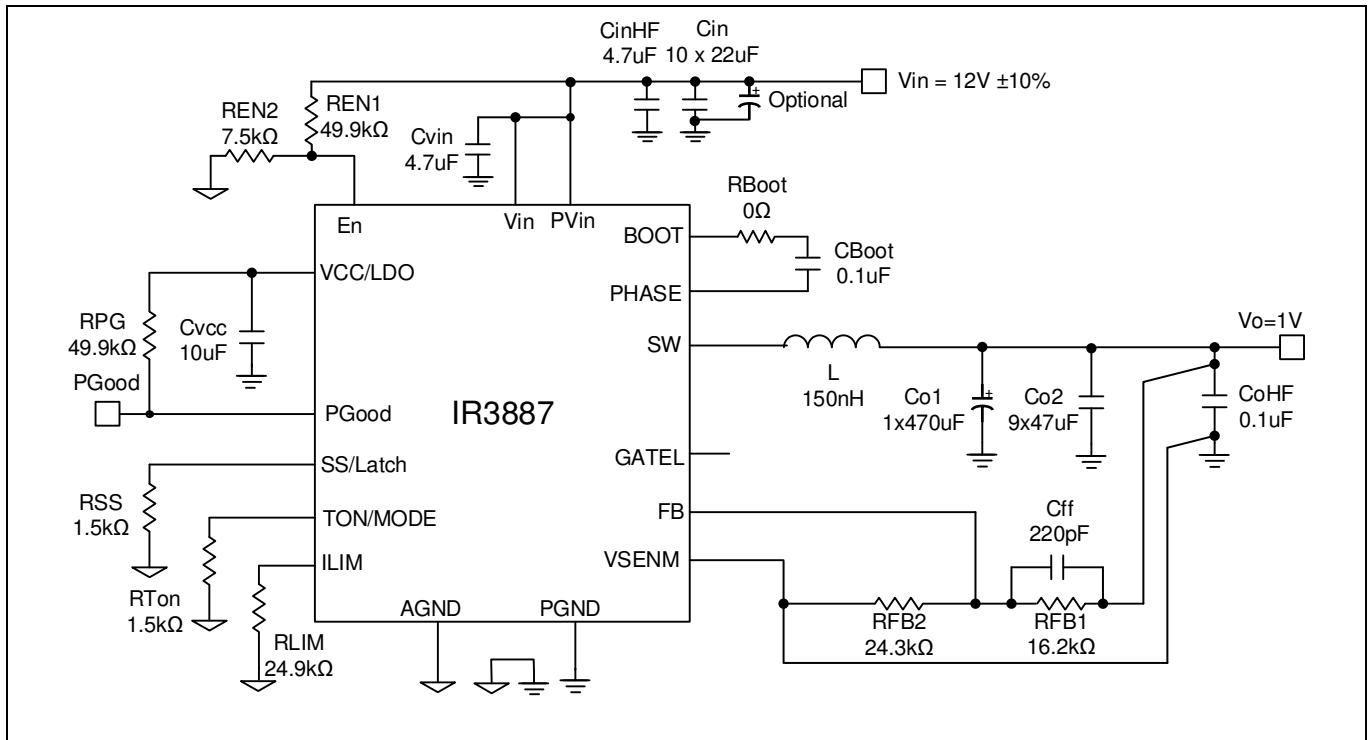

Figure 15 Application diagram of IR3887. $P_{Vin} = 12\text{ V}$, $V_o = 1\text{ V}$, $I_o = 30\text{ A}$, $f_{sw} = 800\text{ kHz}$.

14.2 Typical Operating Waveforms

$P_{Vin} = V_{in} = 12.0\text{ V}$, $V_o = 1\text{ V}$, $I_o = 0 - 30\text{ A}$, $f_{sw} = 800\text{ kHz}$, Room Temperature, no airflow

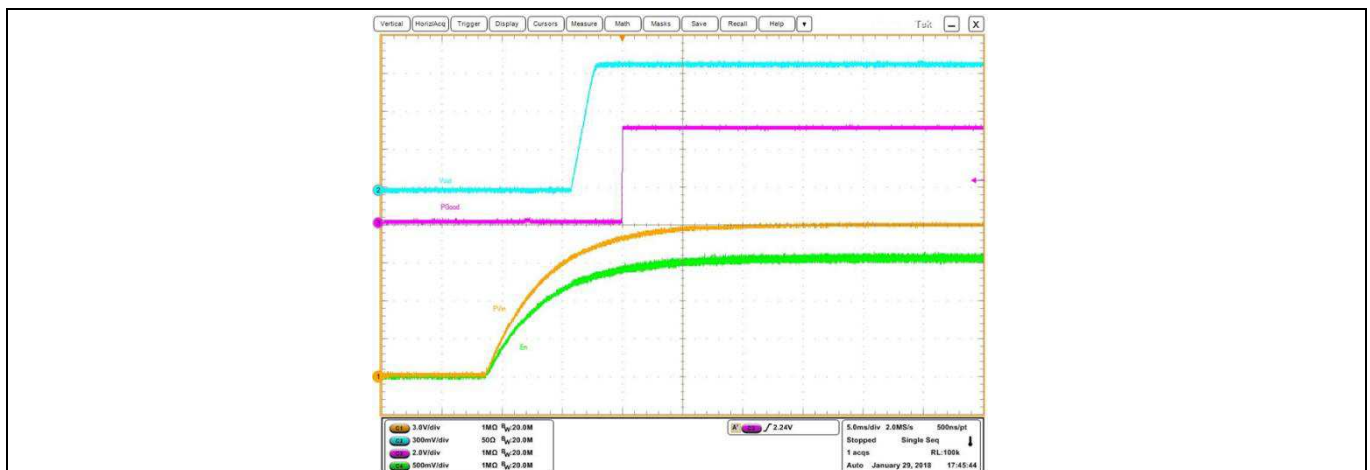

Figure 16 Start up at 30 A Load, (Ch₁: P_{Vin} , Ch₂: V_{out} , Ch₃: P_{Good} , Ch₄: Enable)

Application Information

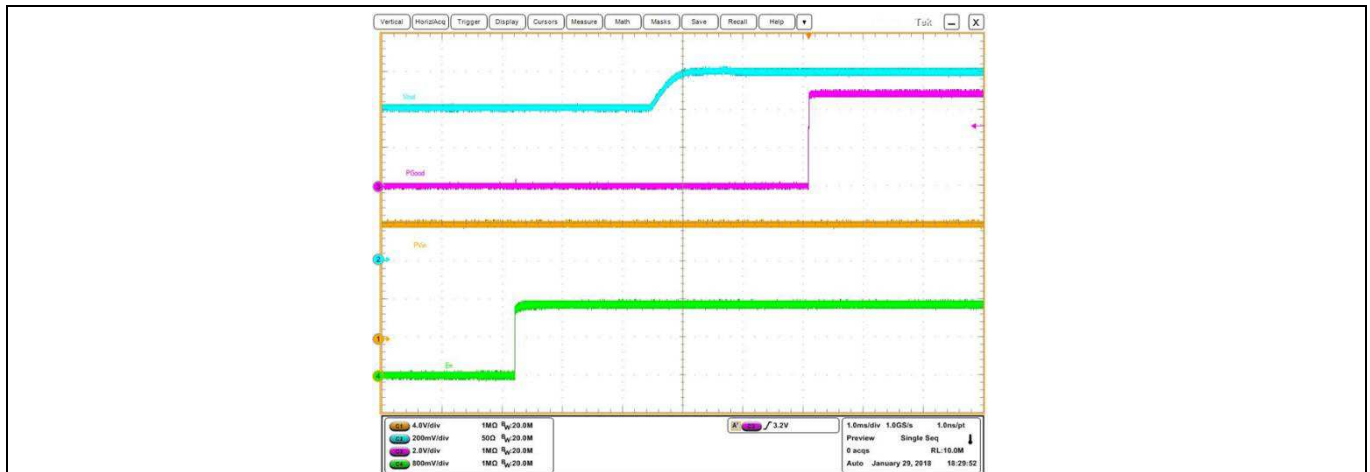

Figure 17 Pre-bias Start up at 0 A Load, (Ch1: PV_{in}, Ch2: V_{out}, Ch3:P_{Good} ,Ch4:Enable)

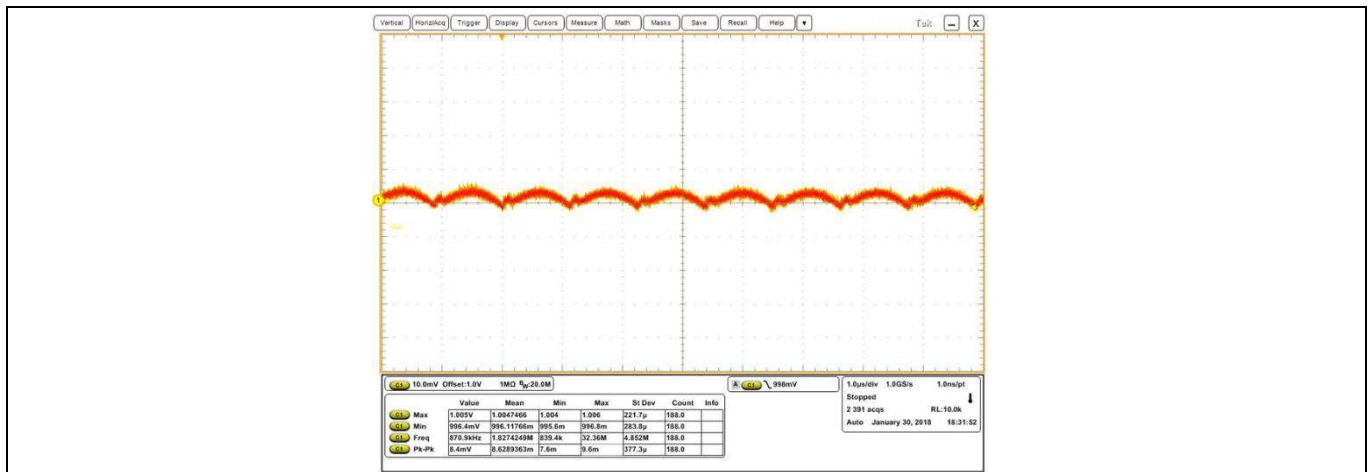

Figure 18 V_{out} ripple at 30 A Load, f_{sw} = 800 kHz, (Ch1: V_o)

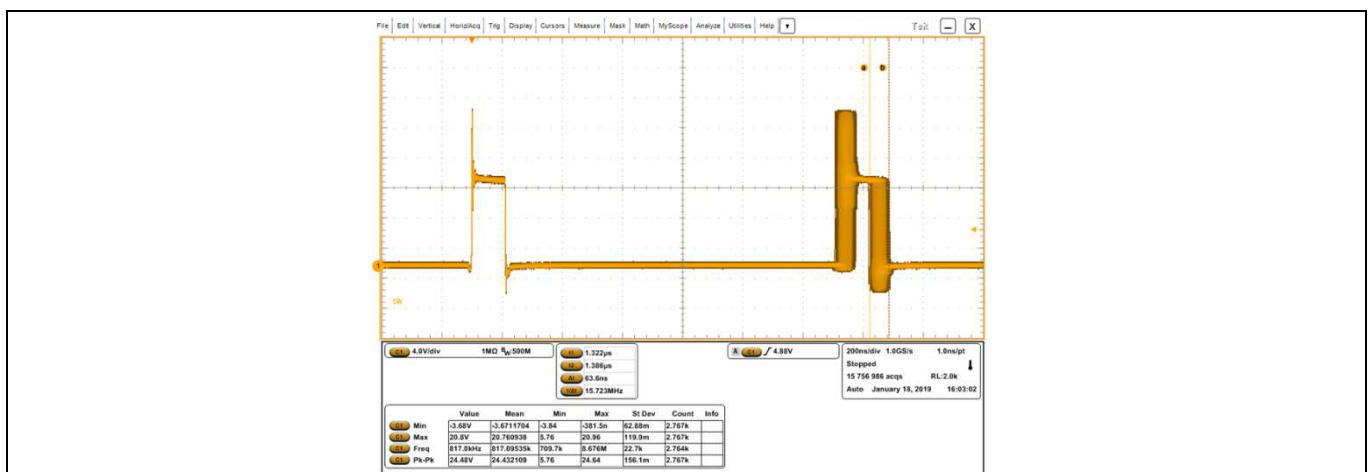

Figure 19 SW node, 30 A load, f_{sw} = 800 kHz

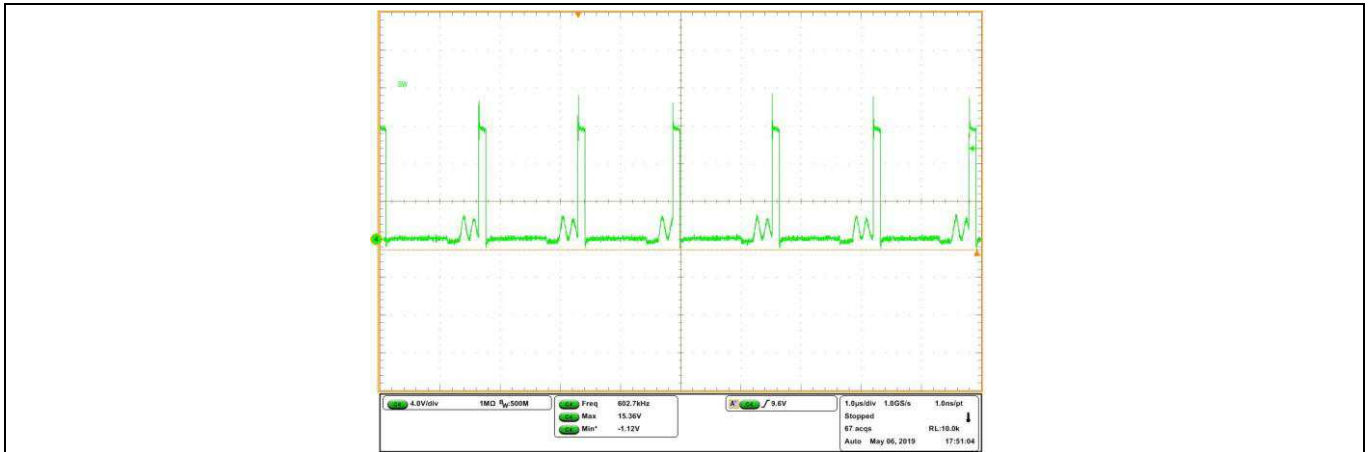

Figure 20 SW node (in DEM), 3.5 A load

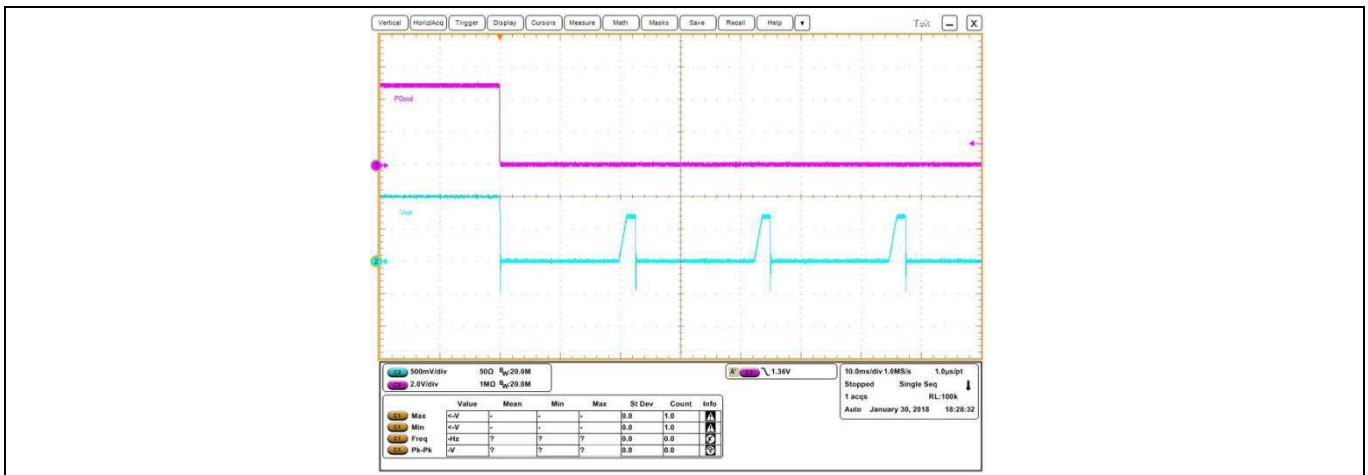

Figure 21 Short circuit and UVP (Hiccup), (Ch₂: V_o, Ch₃:P_{Good})

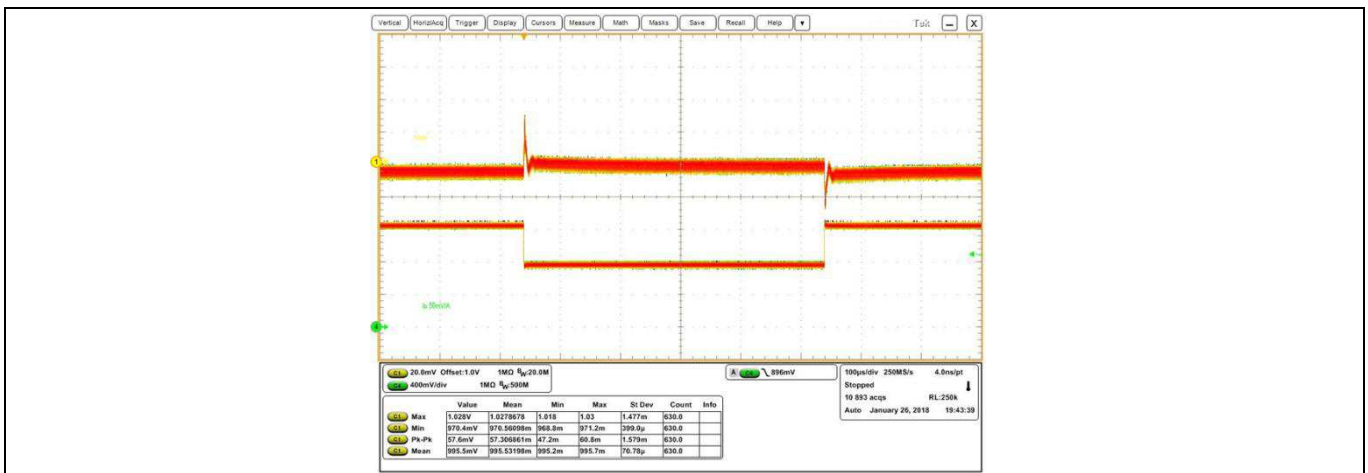

Figure 22 Transient response at 9 A step load current @ 30 A/μs slew rate: I_o = 16 A – 25 A, (Ch₁: V_o, Ch₄: I_o), pk-pk: 60.8 mV, f_{sw} = 800 kHz

15 Layout Recommendations

PCB layout is very important when designing high frequency switching converters. Layout will affect noise pickup and can cause a good design to perform with less than expected results. Following design guidelines are recommended to achieve the best performance.

- Bypass capacitors, including input/output capacitors, Vin, and VCC bypass capacitors, should be placed near the corresponding pins as close as possible.
- Place bypass capacitors from IR3887 power input (Drain of Control MOSFET) to PGND (Source of Synchronous MOSFET) to reduce noise and ringing in the system. The output capacitors should be terminated to a ground plane that is away from the input PGND to mitigate the switching spikes on the Vout. The bypass capacitor for VCC should be terminated to PGND.
- Place a boot strap capacitor near the IR3887 BOOT and PHASE pin as close as possible to minimize the loop inductance.
- SW node copper should only be routed on the top layer to minimize the impact of switching noises
- Connect AGND pin to the PGND pad through a single point connection. On the IR3887 demo board, AGND pin is connected to the exposed PGND pad with a copper trace.
- Via holes can be placed on PVIN and PGND pads to aid thermal dissipation.
- Wide copper polygons are desired for PVin and PGND connections in favor of power losses reduction and thermal dissipation. Sufficient via holes should be used to connect power traces between different layers.
- Single-ended Vo sensing is often used for local sensing. To implement this configuration, following design guidelines should be followed, as illustrated in [Figure 23](#).
 - The output voltage can be sensed from a high-frequency bypass capacitor of 0.1 μF or higher, through a 15 mil PCB trace.
 - Keep the Vout sense line away from any noise sources and shield the sense line with ground planes.
 - The sense trace is connected to a feedback resistor divider with the lower resistor terminated at VSENM pin.
 - Short VSENM pin and AGND pin with a short trace.
- If it is required to sense the output voltage at a remote location, pseudo remoting sensing can be implemented as follows. The configuration is also shown in [Figure 24](#).
 - A pair of PCB traces with 15 mil trace width, running close to each other and away from any noise sources such as inductor and SW nodes, should be used to implement Kelvin sensing of the voltage across a high bypass capacitor of 0.1 μF or higher.
 - The ground connection of the remote sensing signal must be terminated at VSENM pin.
 - The Vout connection of the remote sensing signal must be connected to the feedback resistor divider with the lower feedback resistor terminated at VSENM pin.
 - Shield the pair of remote sensing lines with ground planes above and below.
 - Do **NOT** connect VSENM pin and AGND pin in this configuration
- The EN pin and configuration pins including SS/LATCH, TON/MODE, and ILIM should be terminated to a quiet ground. On the IR3887 standard demo board, they are terminated to the PGND copper plane away from the power current flow. Alternatively, they can be terminated to a dedicated AGND PCB trace.

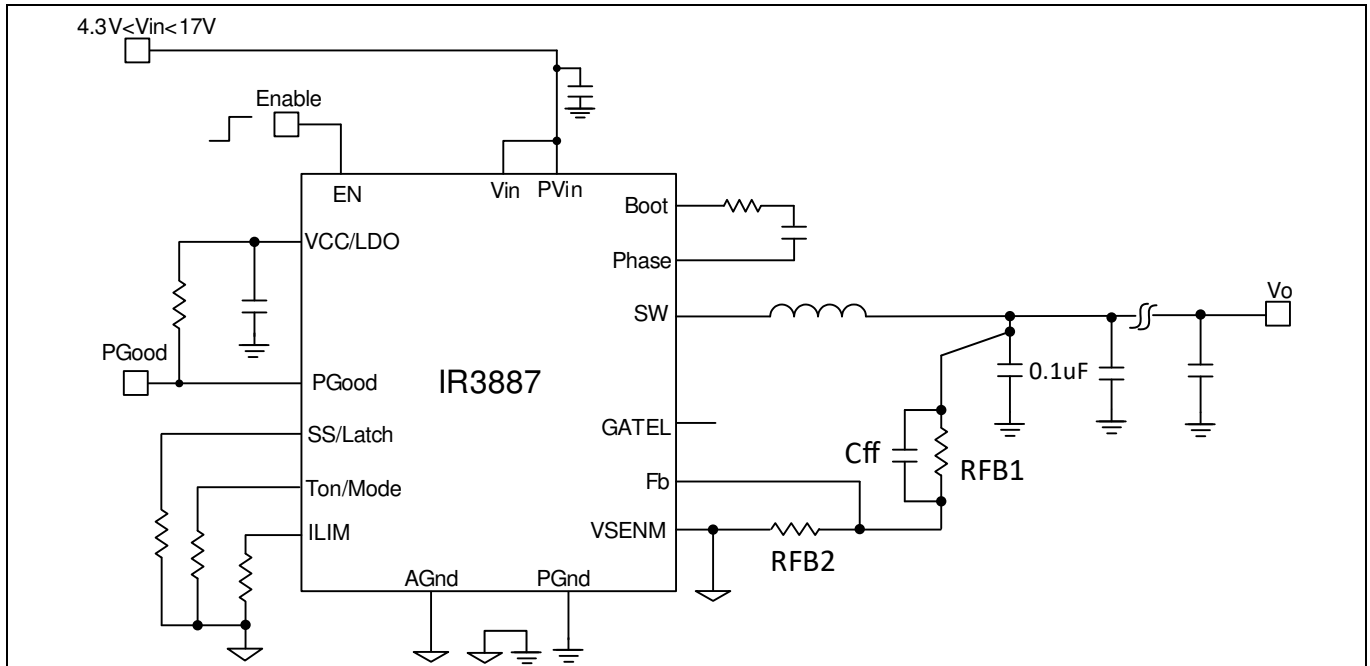

Figure 23 Single-ended V_o local sense configuration

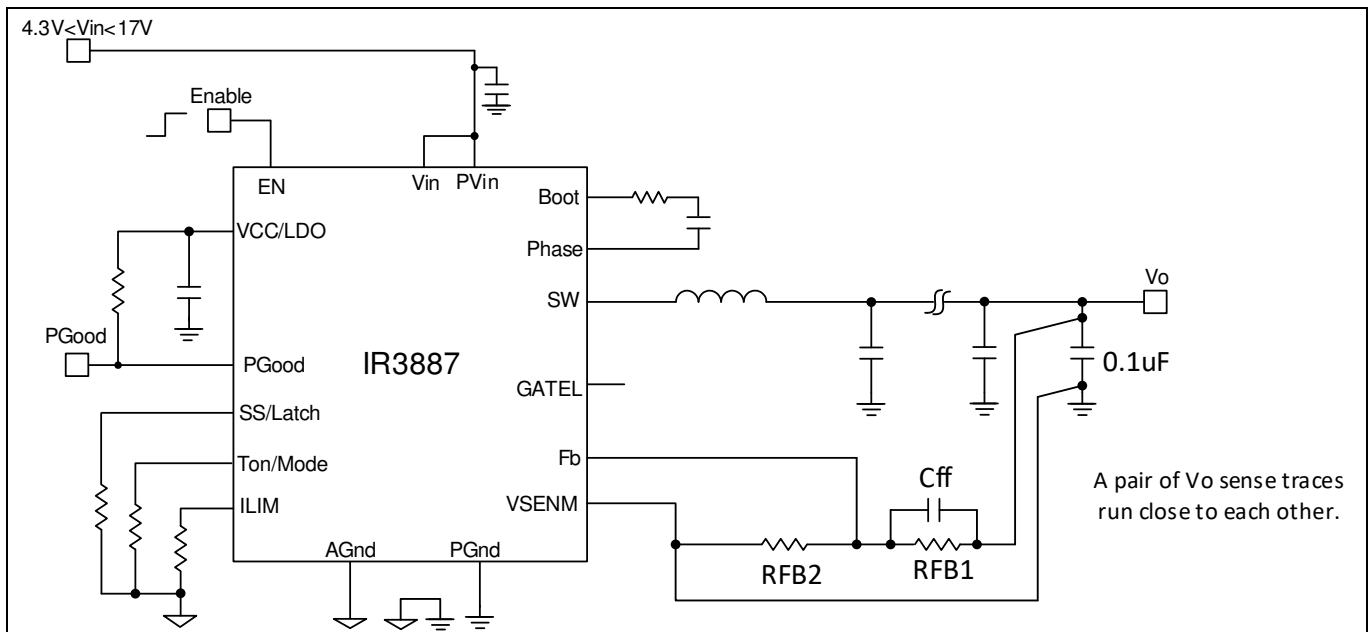

Figure 24 Pseudo remote V_o sense configuration

IR3887 OptiMOS™ IPOL

30 A single-voltage synchronous Buck regulator

Layout Recommendations

Following figures illustrate the PCB layout design of the IR3887 standard demo board with pseudo remote V_o sense.

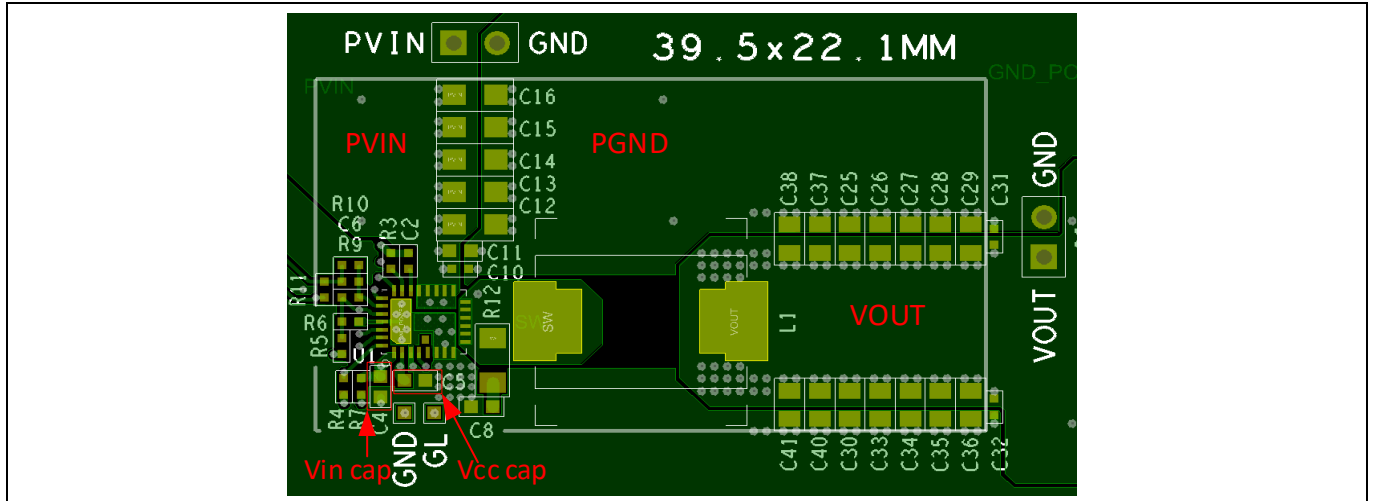

Figure 25 IR3887 Demo Board – Top Layer

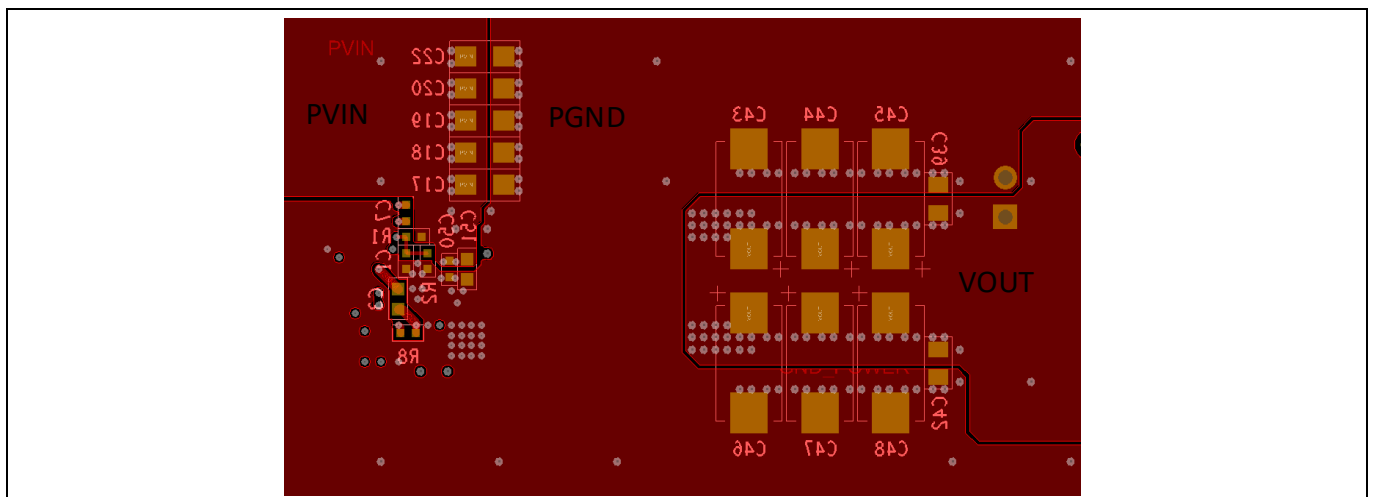

Figure 26 IR3887 Demo Board – Bottom Layer

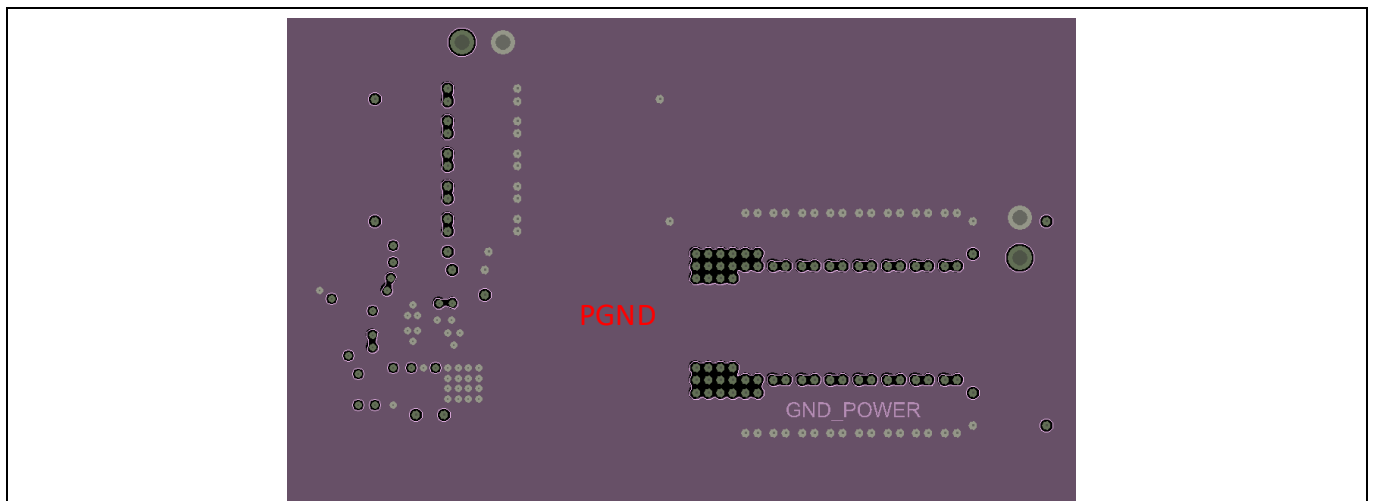

Figure 27 IR3887 Demo Board – 2nd Layer (Ground)

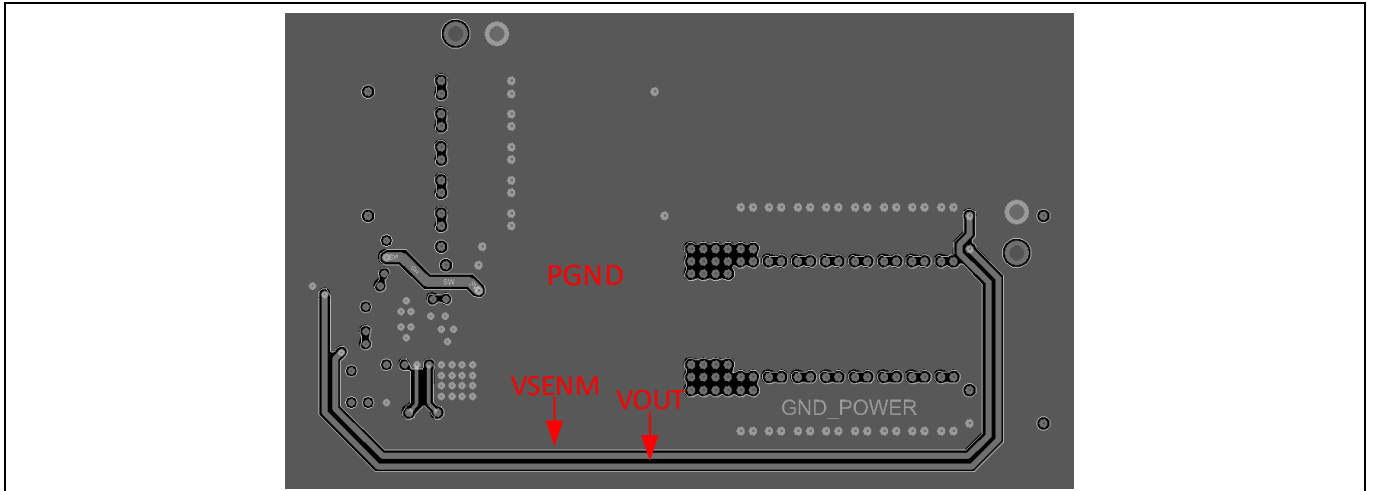

Figure 28 IR3887 Demo Board – 3rd Layer (Ground & Signal)

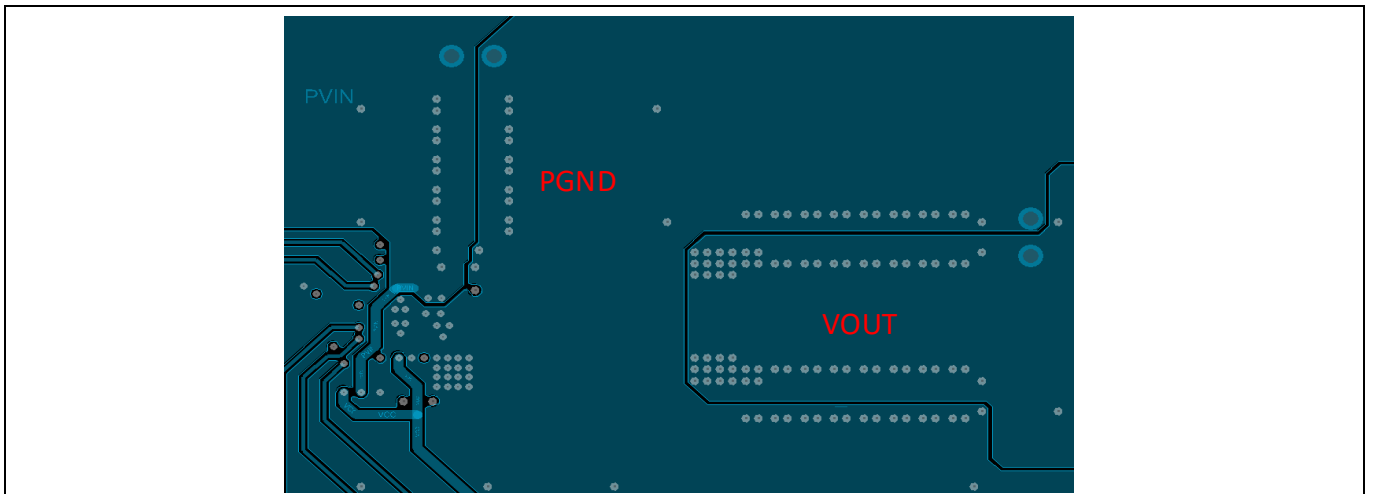

Figure 29 IR3887 Demo Board – 4th Layer (Ground & Signal)

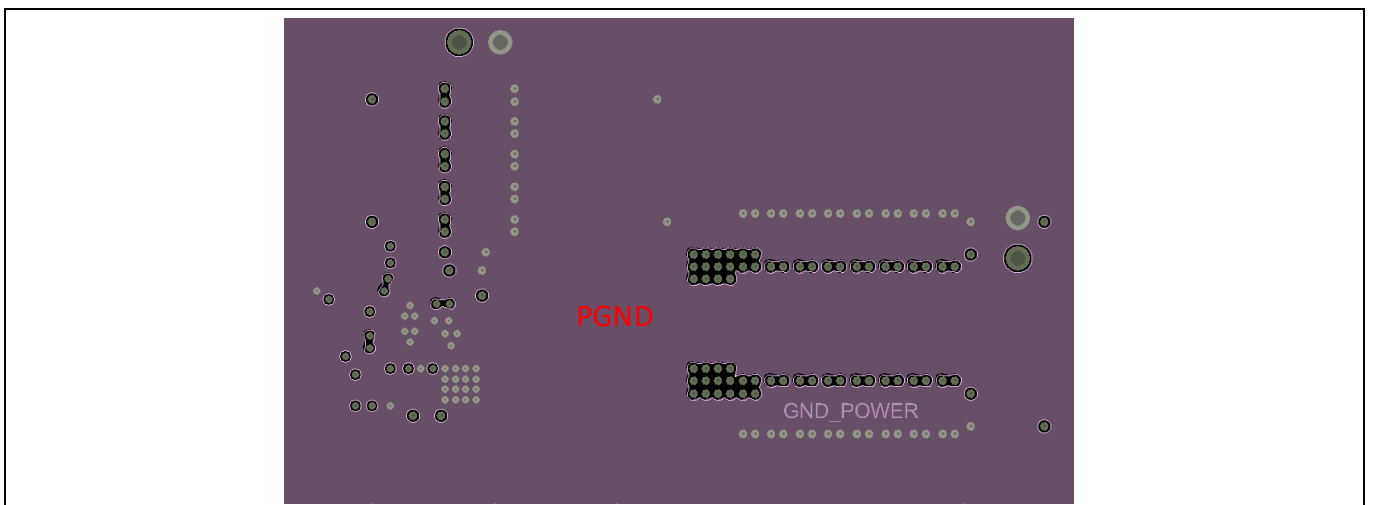

Figure 30 IR3887 Demo Board – 5th Layer (Ground)

Layout Recommendations

15.1 Solder Mask

Evaluation has shown that the best overall performance is achieved using the substrate/PCB layout as shown in the following figures. PQFN devices should be placed to an accuracy of 0.050 mm on both X and Y axes. Self-centering behavior is highly dependent on solders and processes, and experiments should be run to confirm the limits of self-centering on specific processes.

Infineon recommends that larger Power or Land Area pads are Solder Mask Defined (SMD). This allows the underlying copper traces to be as large as possible, which helps in terms of current carrying capability and device cooling capability. When using SMD pads, the underlying copper traces should be at least 0.05 mm larger (on each edge) than the openings in the solder mask. This allows for layers to be misaligned by up to 0.1 mm on both axes. Ensure that the solder resist in-between the smaller signal lead areas is at least 0.15 mm wide, due to the high x/y aspect ratio of the solder mask strip.

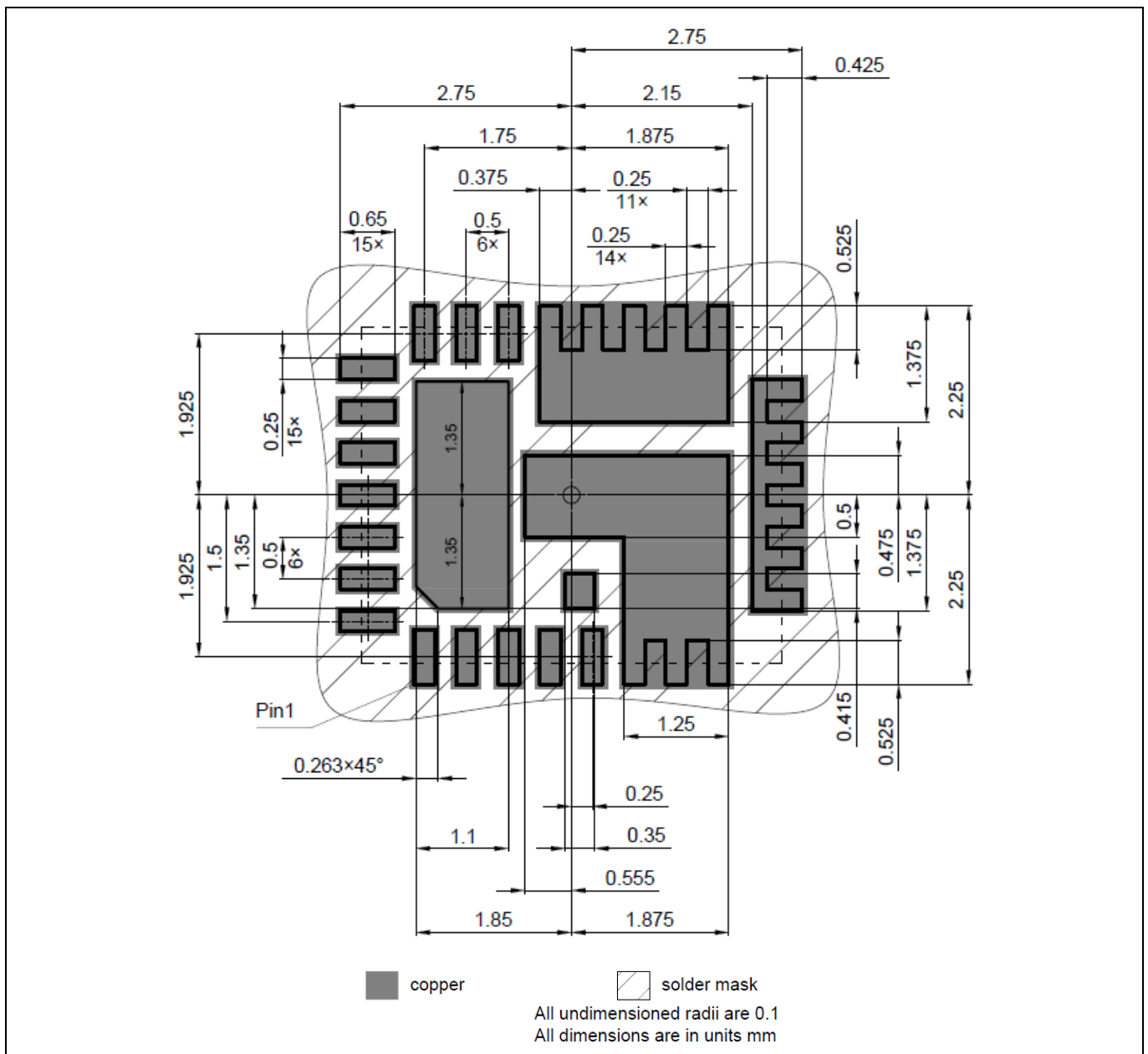

Figure 31 Solder mask (all dimensions in mm)

Package

16 Package

This section includes marking, mechanical and packaging information for the IR3887.

16.1 Marking Information

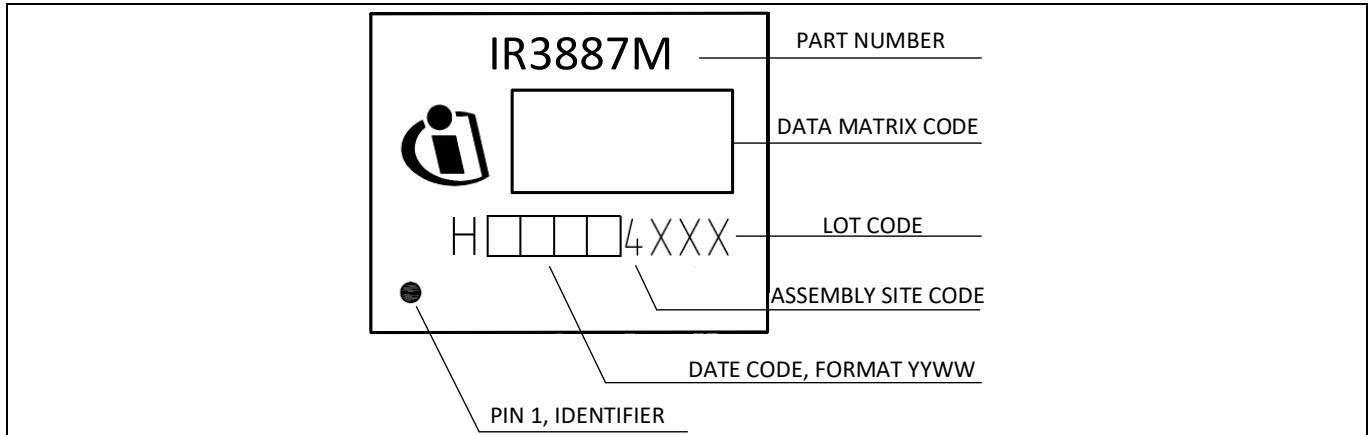
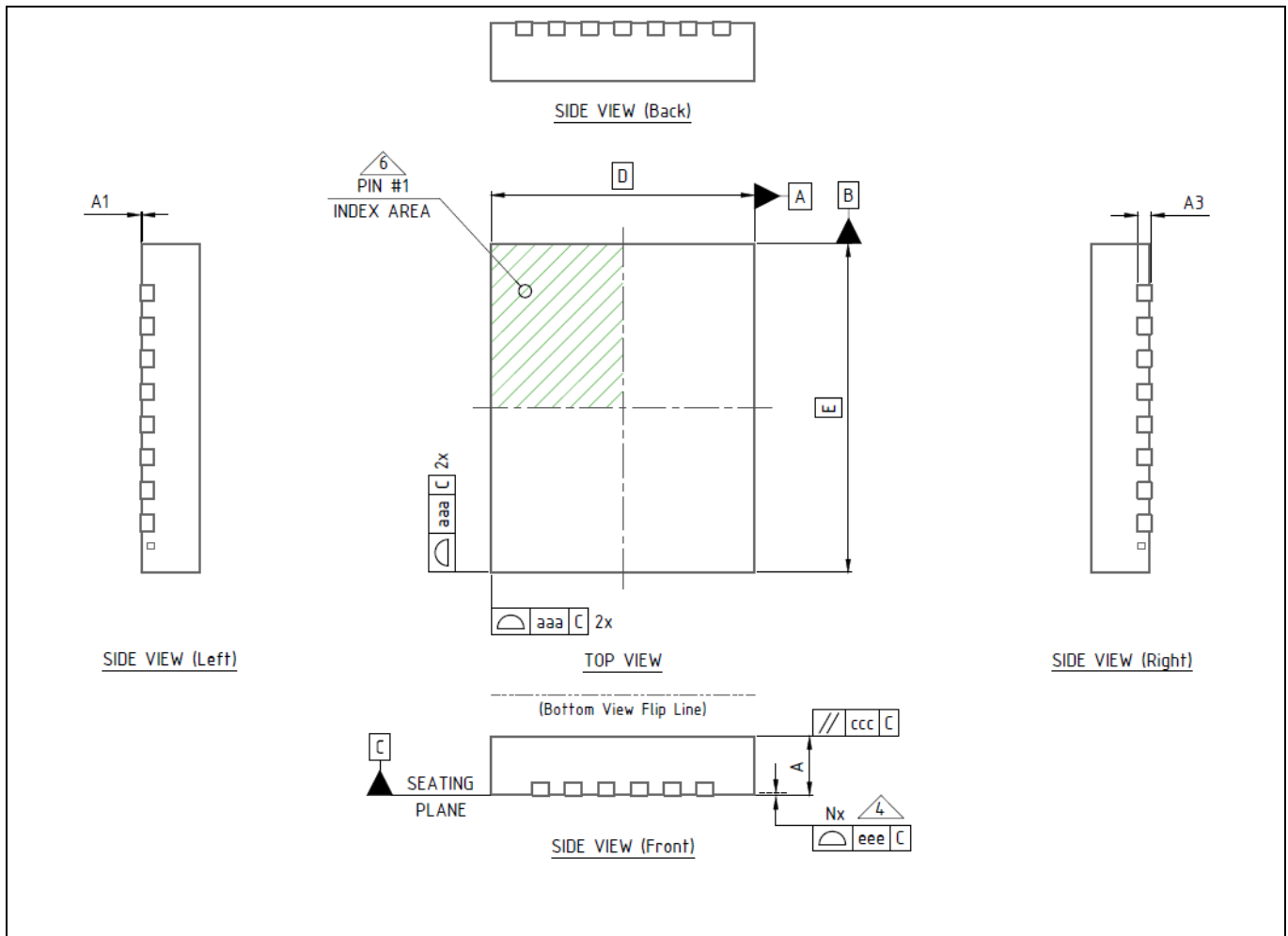

Figure 33 Package Marking

16.2 Dimensions



IR3887 OptiMOS™ IPOL

30 A single-voltage synchronous Buck regulator



Package

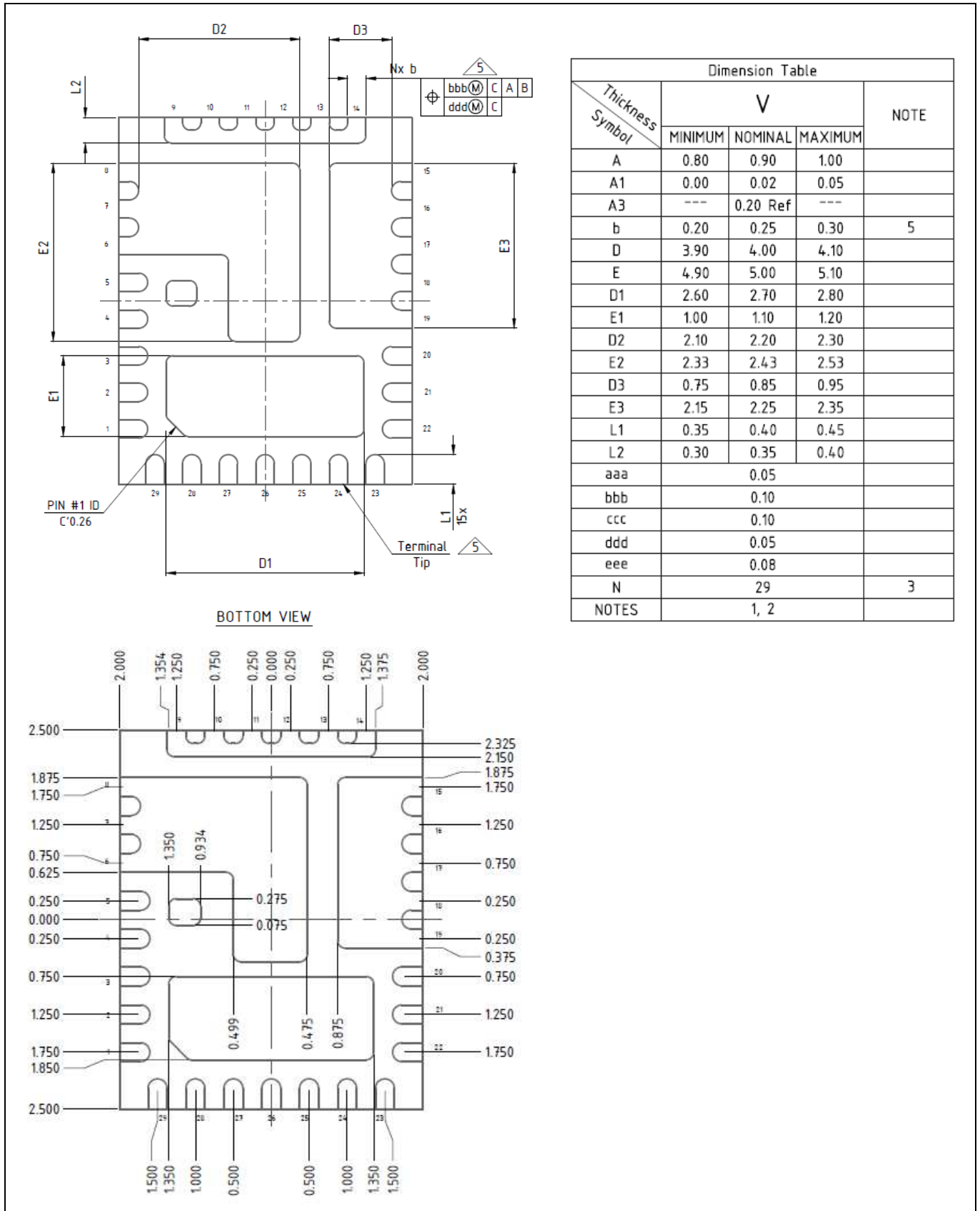

Figure 34 Package Dimensions (all dimensions in mm)

16.3 Tape and Reel Information

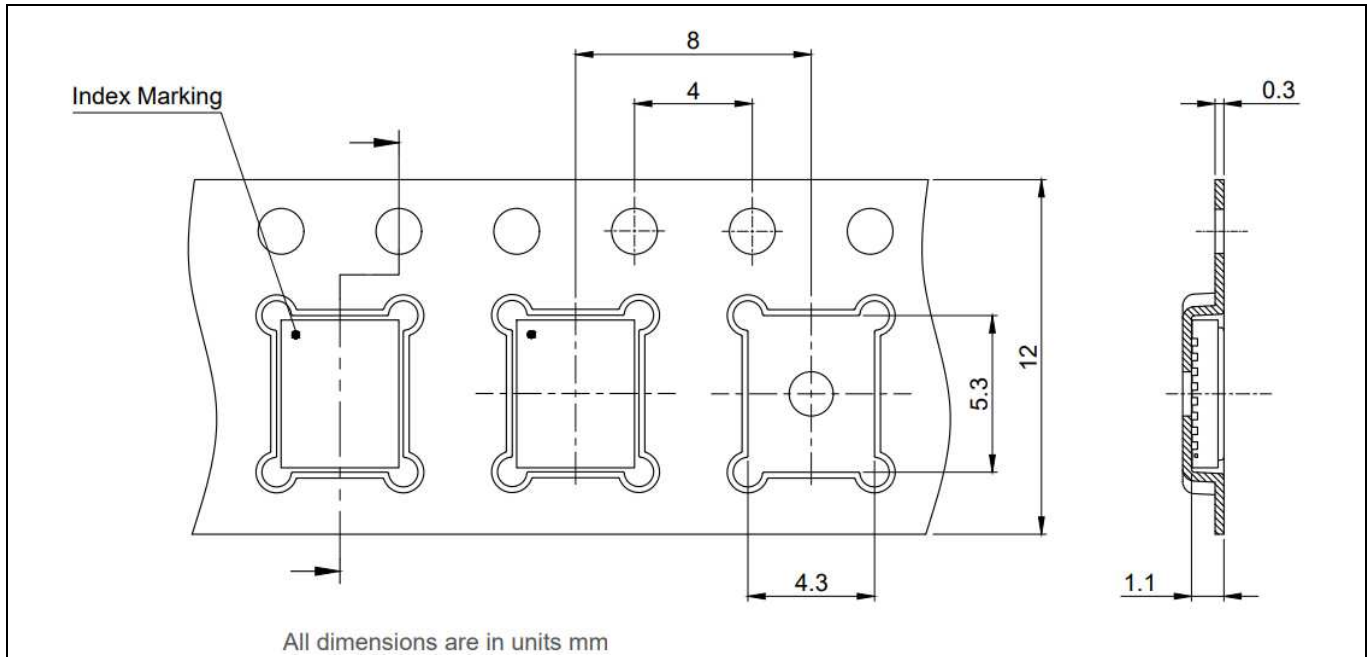

Figure 35 Pin 1 orientation in the tape

17 Environmental Qualifications

Qualification Level		Industrial
Moisture Sensitivity		QFN Package JEDEC Level 2 @ 260 °C
ESD	Human Body Model	ANSI/ESDA/JEDEC JS-001, 2 (2000 V to < 4000 V)
	Charged Device Model	ANSI/ESDA/JEDEC JS-002, C3 (≥ 1000 V)
RoHS2 Compliant		This product is in compliance with EU Directive 2015/863/EU amending Annex II to EU Directive 2011/65/EU (RoHS) and contains Pb according RoHS exemption 7a, Lead in high melting temperature type solders.

18 Evaluation Boards and Support Documentation

Table 9 IR3887 Evaluation Boards and User Guides

Evaluation board	Specifications	Website Address
EVAL_3887_1Vout	12 V±10%, 1 V, 30 A	www.infineon.com/EVAL_3887_1Vout

Table 10 IR3887 Package Information

Device	Package Type	Website Address
IR3887	PG-IQFN-29-1	https://www.infineon.com/cms/en/product/packages/PG-IQFN

Revision History

IR3887

Revision: 2022-04-13, Rev. 2.3

Previous Revision

Revision	Date	Subjects (major changes since last revision)
2.0	2020-03-21	Release of final version
2.1	2020-06-25	(1) Clarify the RoHS compliance spec
2.2	2021-07-27	(1) Add max Vout of 6V to the recommended operation conditions; (2) Update note 8; (3) Correct UVP activation threshold in Section 12.9; (4) Update Table 7; (5) Correct test condition of ILIM in EC table from VCC = 5V to int LDO; (6) Update order info
2.3	2022-04-13	(1) Update Fig 31, 32, 34, and 35; (2) Correct typos in the test conditions of dead band time spec in EC table

Trademarks

All referenced product or service names and trademarks are the property of their respective owners.

We Listen to Your Comments

Any information within this document that you feel is wrong, unclear or missing at all? Your feedback will help us to continuously improve the quality of this document. Please send your proposal (including a reference to this document) to:

erratum@infineon.com

Published by

Infineon Technologies AG
81726 München, Germany
© 2022 Infineon Technologies AG
All Rights Reserved.

Legal Disclaimer

The information given in this document shall in no event be regarded as a guarantee of conditions or characteristics ("Beschaffungsgarantie").

With respect to any examples, hints or any typical values stated herein and/or any information regarding the application of the product, Infineon Technologies hereby disclaims any and all warranties and liabilities of any kind, including without limitation warranties of non-infringement of intellectual property rights of any third party.

In addition, any information given in this document is subject to customer's compliance with its obligations stated in this document and any applicable legal requirements, norms and standards concerning customer's products and any use of the product of Infineon Technologies in customer's applications.

The data contained in this document is exclusively intended for technically trained staff. It is the responsibility of customer's technical departments to evaluate the suitability of the product for the intended application and the completeness of the product information given in this document with respect to such application.

Information

For further information on technology, delivery terms and conditions and prices please contact your nearest Infineon Technologies Office (www.infineon.com).

Warnings

Due to technical requirements, components may contain dangerous substances. For information on the types in question, please contact the nearest Infineon Technologies Office.

The Infineon Technologies component described in this Data Sheet may be used in life-support devices or systems and/or automotive, aviation and aerospace applications or systems only with the express written approval of Infineon Technologies, if a failure of such components can reasonably be expected to cause the failure of that life-support, automotive, aviation and aerospace device or system or to affect the safety or effectiveness of that device or system. Life support devices or systems are intended to be implanted in the human body or to support and/or maintain and sustain and/or protect human life. If they fail, it is reasonable to assume that the health of the user or other persons may be endangered.

Looking for pricing, stock, or lifecycle information?

Click below to explore more details on WIN SOURCE:

- ⊖ [View IR3887MTRPBFAUMA1 on WIN SOURCE](#)
- ⊖ [Infineon Technologies Information](#)

Optimize Your Supply Chain with WIN SOURCE Solutions

- ✓ Global Sourcing Solution
- ✓ Obsolete Management
- ✓ Cost Control Management
- ✓ Shortage Management
- ✓ Alternative Solution
- ✓ Excess Inventory Management