



**THE DATASHEET OF
IPD95R450P7ATMA1**



TPS61097A-33 Low-Input Voltage Synchronous-Boost Converter With Low Quiescent Current

1 Features

- Up to 93% Efficiency at Typical Operating Conditions
- Connection from Battery to Load via Bypass Switch in Shutdown Mode
- Typical Shutdown Current Less Than 5 nA
- Typical Quiescent Current Less Than 5 μ A
- Operating Input Voltage Range From 0.9 V to 5.5 V
- Power-Save Mode for Improved Efficiency at Low Output Power
- Overtemperature Protection
- Small 2.8-mm x 2.9-mm 5-Pin SOT-23 Package

2 Applications

- MSP430 Applications
- All Single-Cell, Two-Cell, and Three-Cell Alkaline, NiCd, NiMH, or Single-Cell Li-Battery Powered Products
- Personal Medical Products
- Fuel Cell and Solar Cell Powered Products
- PDAs
- Mobile Applications
- White LEDs

3 Description

The TPS61097A-33 provides a power supply solution for products powered by either a single-cell, two-cell, or three-cell alkaline, NiCd, or NiMH, or one-cell Li-Ion or Li-polymer battery. They can also be used in fuel cell or solar cell powered devices where the capability of handling low input voltages is essential. Possible output currents depend on the input-to-output voltage ratio. The devices provide output currents up to 100 mA at a 3.3-V output while using a single-cell Li-Ion or Li-Polymer battery. The boost converter is based on a current-mode controller using synchronous rectification to obtain maximum efficiency. The maximum average input current is limited to a value of 400 mA. The converter can be disabled to minimize battery drain. During shutdown, the battery is connected to the load to enable battery backup of critical functions on the load. The device is packaged in a 5-pin SOT-23 package (DBV) measuring 2.8 mm x 2.9 mm.

Device Information⁽¹⁾

PART NUMBER	PACKAGE	BODY SIZE (NOM)
TPS61097A-33	SOT-23 (5)	2.90 mm x 2.90 mm

(1) For all available packages, see the orderable addendum at the end of the datasheet.

Typical Operating Application

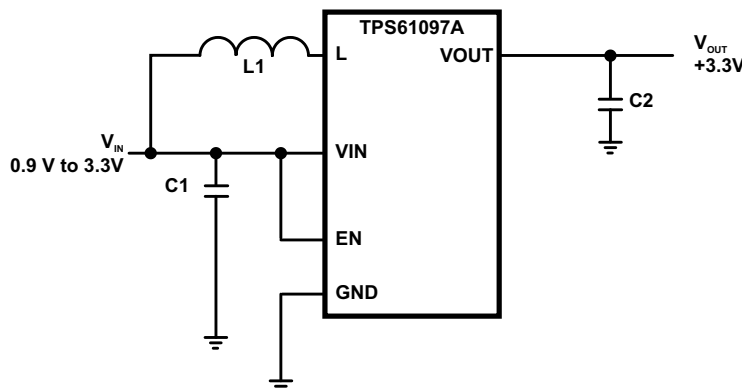

Table of Contents

1	Features	1	8.3	Feature Description.....	10
2	Applications	1	8.4	Device Functional Modes.....	11
3	Description	1	9	Application and Implementation	12
4	Revision History	2	9.1	Application Information.....	12
5	Pin Configuration and Functions	3	9.2	Typical Application	13
6	Specifications	3	10	Power Supply Recommendations	16
6.1	Absolute Maximum Ratings	3	11	Layout	16
6.2	ESD Ratings.....	3	11.1	Layout Guidelines	16
6.3	Recommended Operating Conditions.....	3	11.2	Layout Example	16
6.4	Thermal Information	4	12	Device and Documentation Support	17
6.5	Electrical Characteristics.....	4	12.1	Device Support	17
6.6	Typical Characteristics.....	5	12.2	Trademarks	17
7	Parameter Measurement Information	8	12.3	Electrostatic Discharge Caution.....	17
8	Detailed Description	9	12.4	Glossary	17
8.1	Overview	9	13	Mechanical, Packaging, and Orderable Information	17
8.2	Functional Block Diagram	9			

4 Revision History

Changes from Original (January 2014) to Revision A

Page

- Added *Handling Rating* table, *Feature Description* section, *Device Functional Modes*, *Application and Implementation* section, *Power Supply Recommendations* section, *Layout* section, *Device and Documentation Support* section, and *Mechanical, Packaging, and Orderable Information* section **1**

5 Pin Configuration and Functions

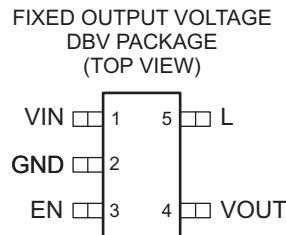

Pin Functions

PIN		I/O	DESCRIPTION
NO.	NAME		
1	VIN	I	Boost converter input voltage.
2	GND	–	Control / logic ground.
3	EN	I	Enable input (1 = enabled, 0 = disabled). EN must be actively terminated high or low.
4	VOUT	O	Boost converter output.
5	L	I	Connection for inductor.

6 Specifications

6.1 Absolute Maximum Ratings

Over operating free-air temperature range (unless otherwise noted)⁽¹⁾

		MIN	MAX	UNIT	
V _I	Input voltage range	VIN	–0.3	7	V
		L	–0.3	7	
		VOUT	–0.3	7	
		EN	–0.3	7	
I _{MAX}	Maximum continuous output current		400	mA	
T _J	Junction temperature range	–40	150	°C	
T _{stg}	Storage temperature range	–65	150	°C	

(1) Stresses beyond those listed under *Absolute Maximum Ratings* may cause permanent damage to the device. These are stress ratings only, and functional operation of the device at these or any other conditions beyond those indicated under *Recommended Operating Conditions* is not implied. Exposure to absolute-maximum-rated conditions for extended periods may affect device reliability.

6.2 ESD Ratings

		VALUE	UNIT	
V _(ESD)	Electrostatic discharge	Human-body model (HBM), per ANSI/ESDA/JEDEC JS-001 ⁽¹⁾	±2000	V
		Charged-device model (CDM), per JEDEC specification JESD22-C101 ⁽²⁾	±1000	

(1) JEDEC document JEP155 states that 500-V HBM allows safe manufacturing with a standard ESD control process.

(2) JEDEC document JEP157 states that 250-V CDM allows safe manufacturing with a standard ESD control process.

6.3 Recommended Operating Conditions

		MIN	MAX	UNIT
V _{IN}	Input voltage range	0.9	5.5	V
V _{EN}	Enable voltage range	0	5.5	V
T _A	Operating free air temperature range	–40	85	°C
T _J	Operating junction temperature range	–40	125	°C

6.4 Thermal Information

THERMAL METRIC ⁽¹⁾		TPS61097A-33	UNIT
		DBV	
		5 PINS	
θ_{JA}	Junction-to-ambient thermal resistance	208.7	°C/W
θ_{JCTop}	Junction-to-case (top) thermal resistance	124.5	
θ_{JB}	Junction-to-board thermal resistance	36.9	
ψ_{JT}	Junction-to-top characterization parameter	14.7	
ψ_{JB}	Junction-to-board characterization parameter	36	

(1) For more information about traditional and new thermal metrics, see the *IC Package Thermal Metrics* application report, [SPRA953](#).

6.5 Electrical Characteristics

Over recommended free-air temperature range and over recommended input voltage range (typical at an ambient temperature range of 25°C) (unless otherwise noted)

PARAMETER		TEST CONDITIONS	MIN	TYP	MAX	UNIT	
DC/DC STAGE							
V_{IN}	Input voltage		0.9		5.5	V	
V_{OUT}	Output voltage	$V_{IN} = 1.2\text{ V}, I_{OUT} = 10\text{ mA}$	3.20	3.30	3.40		
I_{SW}	Switch current limit	$V_{OUT} = 3.3\text{ V}$	200	400	475	mA	
	Rectifying switch on resistance	$V_{OUT} = 3.3\text{ V}$		1.0		Ω	
	Main switch on resistance	$V_{OUT} = 3.3\text{ V}$		1.0			
	Bypass switch on resistance	$V_{IN} = 1.2\text{ V}, I_{OUT} = 100\text{ mA}$		3.4			
	Line regulation	$V_{IN} < V_{OUT}, V_{IN} = 1.2\text{ V to } 1.8\text{ V}, I_{OUT} = 10\text{ mA}$		0.5%			
	Load regulation	$V_{IN} < V_{OUT}, I_{OUT} = 10\text{ mA to } 50\text{ mA}, V_{IN} = 1.8\text{ V}$		0.5%			
I_Q	Quiescent current	V_{IN}	$I_{OUT} = 0\text{ mA}, V_{EN} = V_{IN} = 1.2\text{ V}, V_{OUT} = 3.5\text{ V}$		2	4	μA
		V_{OUT}			5	8	
I_{SD}	Shutdown current	V_{IN}	$V_{EN} = 0\text{ V}, V_{IN} = 1.2\text{ V}, I_{OUT} = 0\text{ mA}$		0.005	0.15	μA
		V_{IN}			$V_{EN} = 0\text{ V}, V_{IN} = 3\text{ V}, I_{OUT} = 0\text{ mA}$		
	Leakage current into L	$V_{EN} = 0\text{ V}, V_{IN} = 1.2\text{ V}, V_L = 1.2\text{ V}$		0.01			1
CONTROL STAGE							
	EN input current	$EN = 0\text{ V or } EN = V_{IN}$		0.01	0.1	μA	
V_{IL}	Logic low level, EN falling edge				0.58	V	
V_{IH}	Logic high level, EN rising edge		0.78		$V_{IN} + 1.0\text{ V}$		
OTP	Overtemperature protection			150		°C	
OTP _{HYST}	Overtemperature hysteresis			20			
V_{UVLO}	Undervoltage lock-out threshold for turn off	V_{IN} decreasing		0.6	0.8	V	

6.6 Typical Characteristics

Refer to [Figure 19](#) for reference designators.

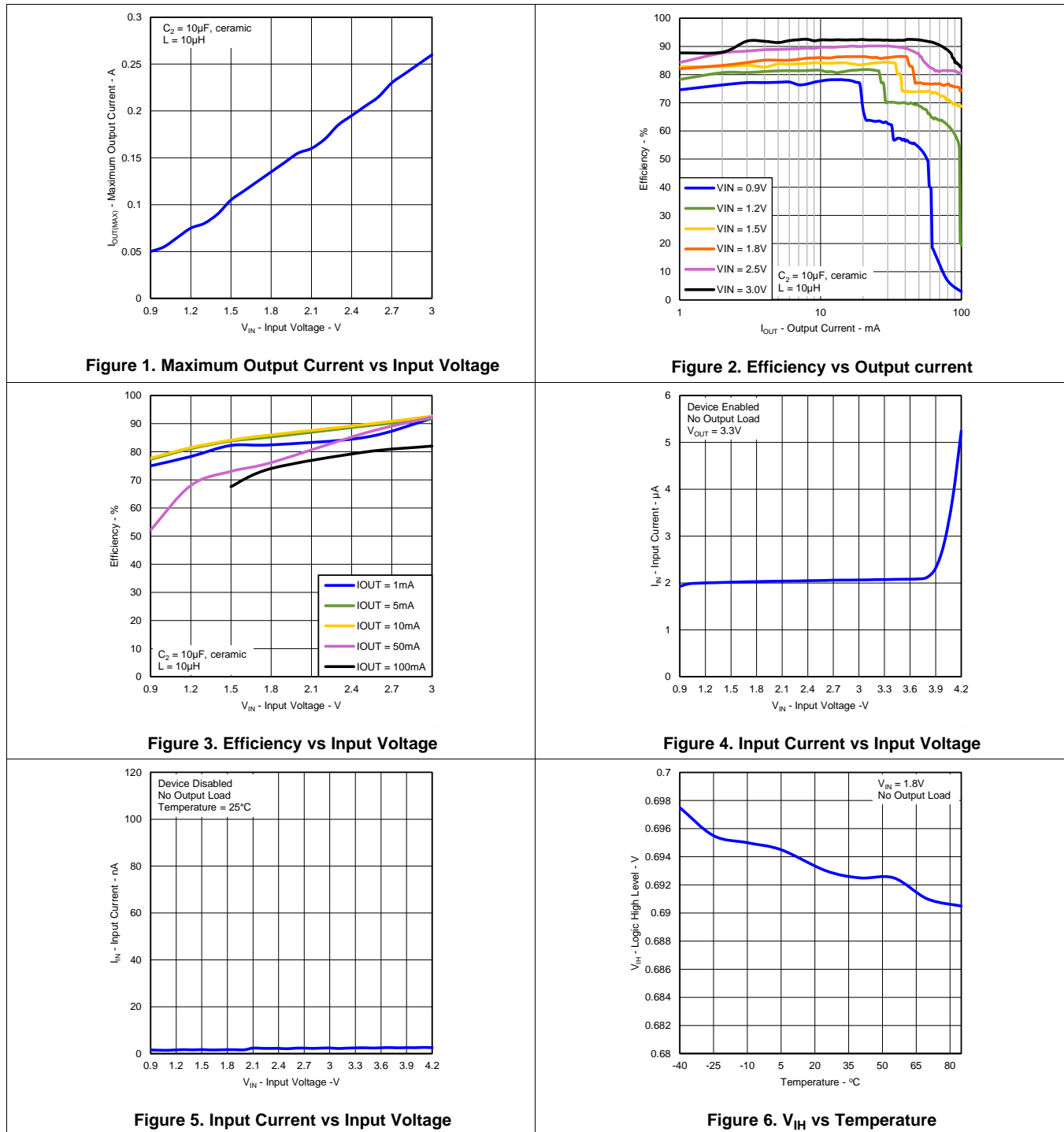

Typical Characteristics (continued)

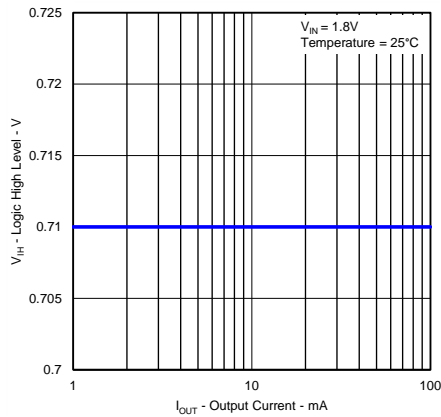

Figure 7. V_{IH} vs Output Current

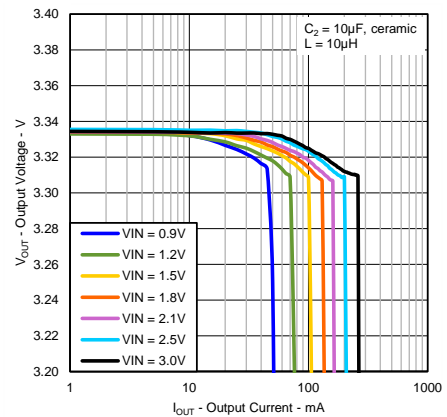

Figure 8. Output Voltage vs Output Current

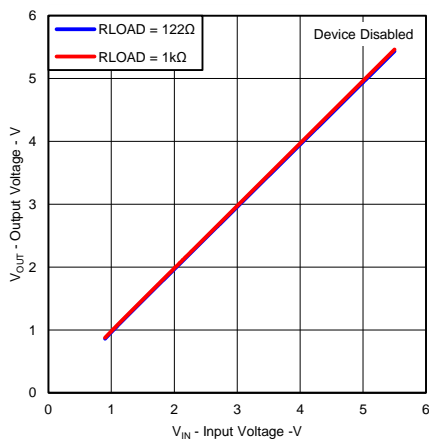

Figure 9. Output Voltage vs Input Voltage

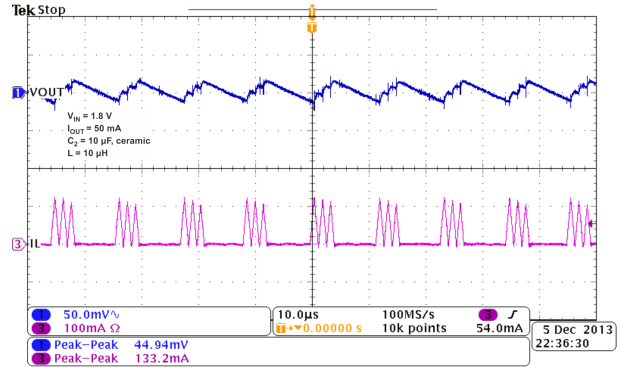

Figure 10. Output Voltage Ripple

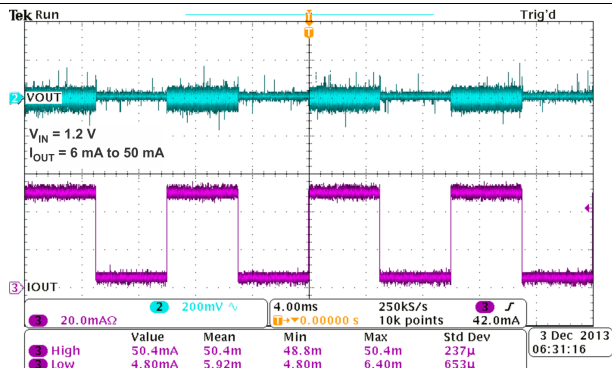

Figure 11. Load Transient Response

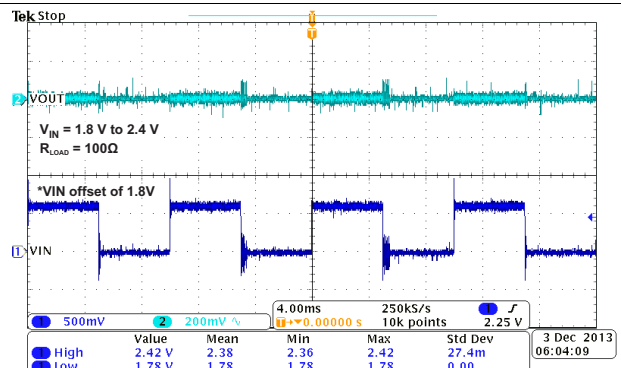
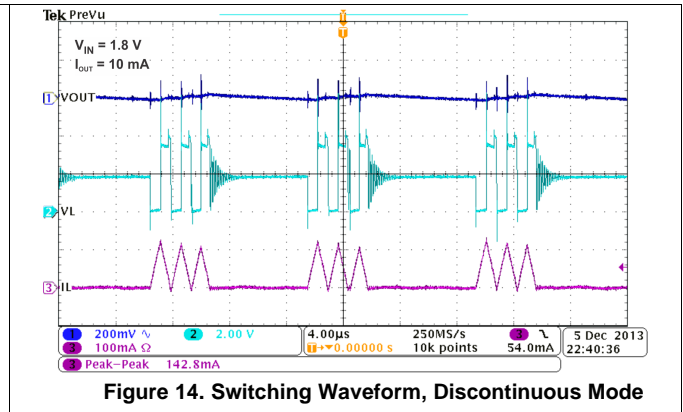
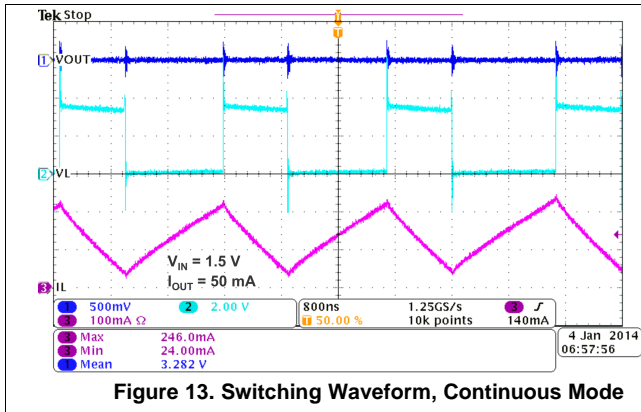

Figure 12. Line Transient Response

Typical Characteristics (continued)



7 Parameter Measurement Information

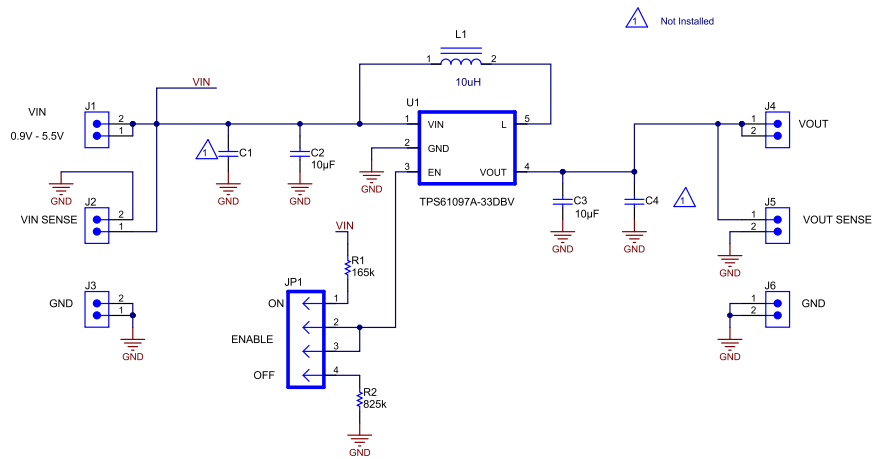

Figure 15. Measurement Test Circuit

Table 1. List of Components

REFERENCE	MANUFACTURER	PART NO.
C2	Murata	GRM319R61A106KE19 10µF 10V X5R 1206 20%
C3	Murata	GRM319R61A106KE19 10µF 10V X5R 1206 20%
L1	Coilcraft	DO3314-103MLC

8 Detailed Description

8.1 Overview

The TPS61097A-33 is a high performance, high efficiency switching boost converter. To achieve high efficiency the power stage is realized as a synchronous boost topology. For the power switching, two actively controlled low R_{DSon} power MOSFETs are implemented.

8.2 Functional Block Diagram

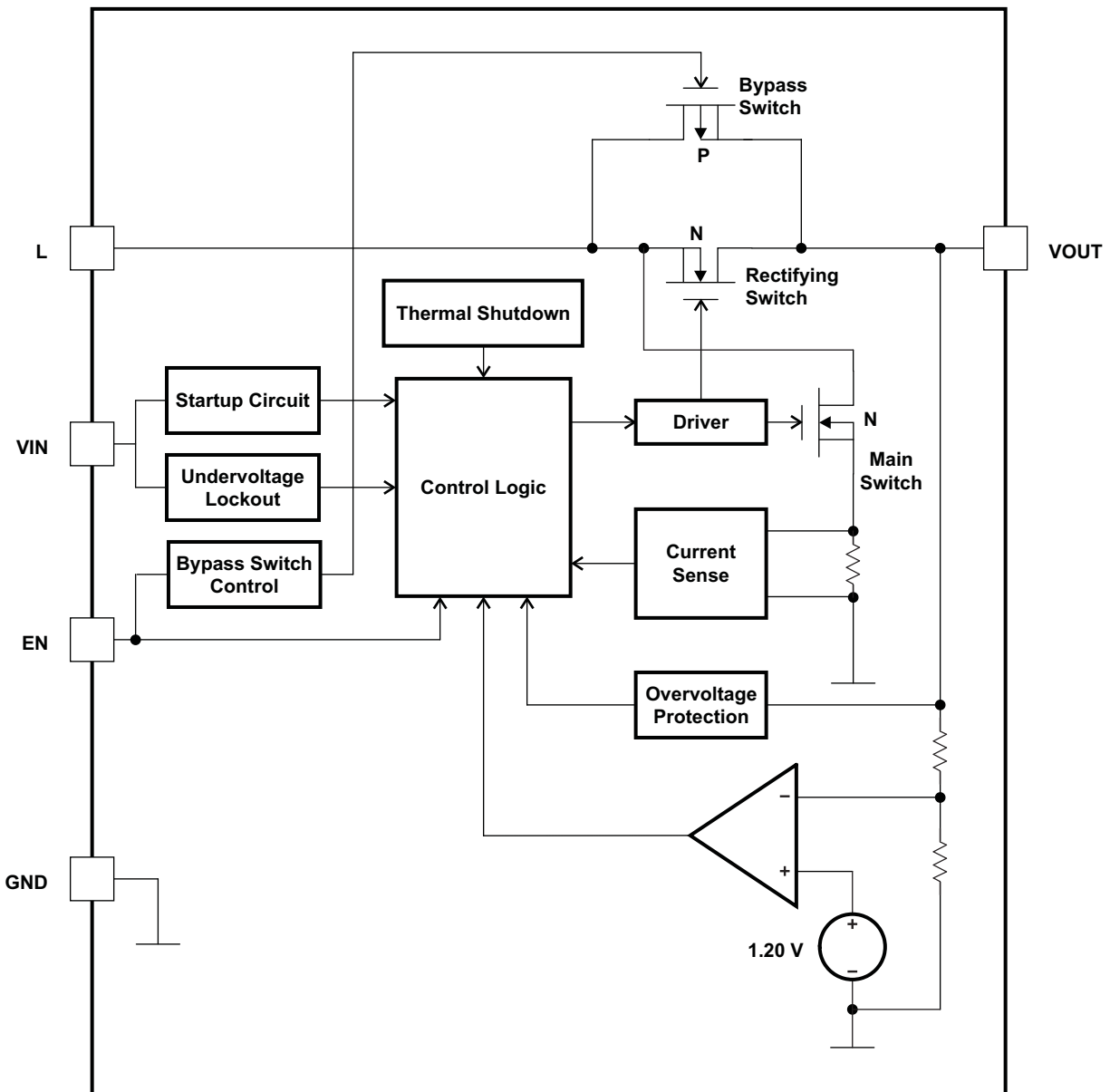

8.3 Feature Description

8.3.1 Controller Circuit

The device is controlled by a hysteretic current mode controller. This controller regulates the output voltage by keeping the inductor ripple current constant in the range of 200 mA and adjusting the offset of this inductor current depending on the output load. If the required average input current is lower than the average inductor current defined by this constant ripple the inductor current goes discontinuous to keep the efficiency high at low load conditions.

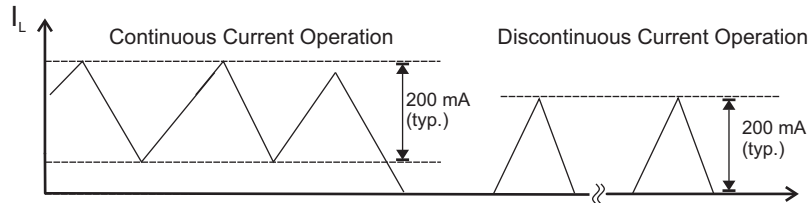

Figure 16. Hysteretic Current Operation

The output voltage V_{OUT} is monitored via the feedback network which is connected to the voltage error amplifier. To regulate the output voltage, the voltage error amplifier compares this feedback voltage to the internal voltage reference and adjusts the required offset of the inductor current accordingly.

8.3.2 Device Enable and Shutdown Mode

The device is enabled when EN is set high and shut down when EN is low. During shutdown, the converter stops switching and all internal control circuitry is turned off.

8.3.3 Bypass Switch

The TPS61097A-33 contains a P-channel MOSFET (Bypass Switch) in parallel with the synchronous rectifying MOSFET. When the IC is enabled ($V_{EN} > V_{IH}$), the Bypass Switch is turned off to allow the IC to work as a standard boost converter. When the IC is disabled ($V_{EN} < V_{IL}$) the Bypass Switch is turned on to provide a direct, low impedance connection from the input voltage (at the L pin) to the load (VOUT). The Bypass Switch is not impacted by Undervoltage lockout, Overvoltage or Thermal shutdown.

8.3.4 Startup

After the EN pin is tied high, the device starts to operate. If the input voltage is not high enough to supply the control circuit properly a startup oscillator starts to operate the switches. During this phase the switching frequency is controlled by the oscillator and the maximum switch current is limited. As soon as the device has built up the output voltage to about 1.8 V, high enough for supplying the control circuit, the device switches to its normal hysteretic current mode operation. The startup time depends on input voltage and load current.

8.3.5 Operation at Output Overload

If in normal boost operation the inductor current reaches the internal switch current limit threshold the main switch is turned off to stop further increase of the input current. In this case the output voltage will decrease since the device can not provide sufficient power to maintain the set output voltage.

If the output voltage drops below the input voltage the backgate diode of the rectifying switch gets forward biased and current starts flow through it. Because this diode cannot be turned off, the load current is only limited by the remaining DC resistances. As soon as the overload condition is removed, the converter automatically resumes normal operation and enters the appropriate soft start mode depending on the operating conditions.

8.3.6 Undervoltage Lockout

An undervoltage lockout function stops the operation of the converter if the input voltage drops below the typical undervoltage lockout threshold. This function is implemented in order to prevent malfunctioning of the converter. The undervoltage lockout function has no control of the Bypass Switch. If the Bypass Switch is enabled ($V_{EN} < V_{IL}$) there is no impact during an undervoltage condition, and the Bypass Switch remains on.

Feature Description (continued)

8.3.7 Overtemperature Protection

The device has a built-in temperature sensor which monitors the internal IC temperature. If the temperature exceeds the programmed threshold (OTP), the device stops operating. As soon as the IC temperature has decreased below the programmed threshold (OTP - OTP_{HYST}), it starts operating again. There is a built-in hysteresis to avoid unstable operation at IC temperatures at the overtemperature threshold.

8.4 Device Functional Modes

EN	DEVICE STATE
H	Boost Converter
L	Bypass Switch

9 Application and Implementation

NOTE

Information in the following applications sections is not part of the TI component specification, and TI does not warrant its accuracy or completeness. TI's customers are responsible for determining suitability of components for their purposes. Customers should validate and test their design implementation to confirm system functionality.

9.1 Application Information

9.1.1 Adjustable Bypass Switching

The EN pin can be set up as a low voltage control for the bypass switch. By setting the desired ratio of R1 and R2, the TPS61097A-33 can be set to switch on the bypass at a defined voltage level on VIN. For example, setting R1 and R2 to 200 KΩ would set V_{EN} to half of VIN. The voltage level of VIN engaging the bypass switch is based on the V_{IL} level of EN (0.58 V). If VIN is less than 1.16 V then the bypass switch will be enabled. For VIN values above 1.56 V (50% of V_{IH}) the bypass switch is disabled.

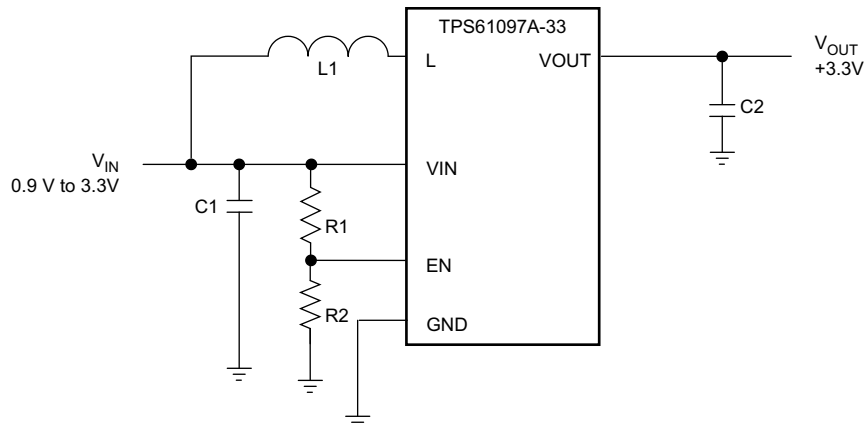

Figure 17. Adjustable Bypass Switching

9.1.2 Managing Inrush Current

Upon startup, the output capacitor of the boost converter can act as a virtual short circuit. The amount of inrush current is dependent on the rate of increase of the input voltage, the inductance used with the converter, the output capacitance and the parasitic circuit resistance. One method to reduce the inrush current is to use a load switch with controlled turn-on. Texas Instruments has a large offering of controlled slew rate load switches which can be found at www.ti.com/loadswitches. Below is an example circuit that has a load switch with controlled turn-on.

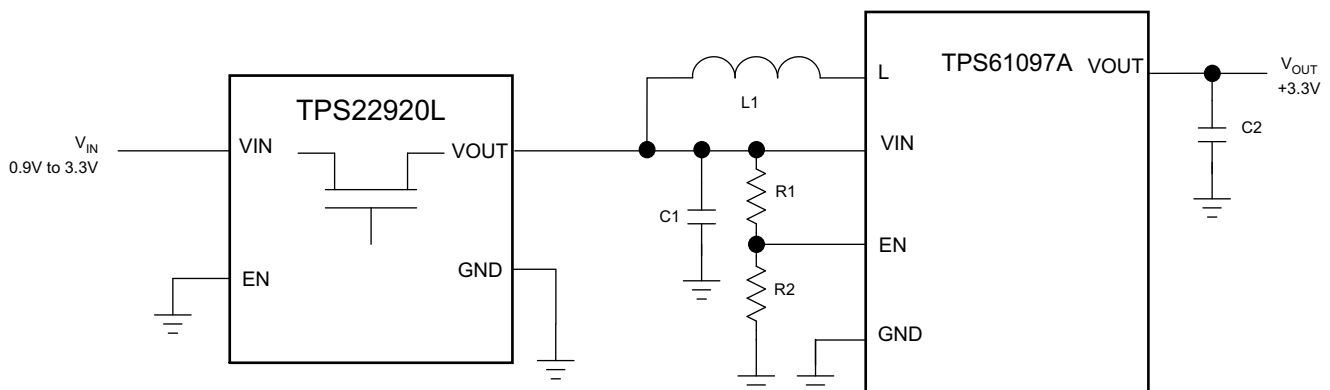

Figure 18. Example Circuit with Load Switch

Application Information (continued)

9.1.3 Thermal Considerations

Implementation of integrated circuits in low-profile and fine-pitch surface-mount packages typically requires special attention to power dissipation. Many system-dependent issues such as thermal coupling, airflow, added heat sinks and convection surfaces, and the presence of other heat-generating components affect the power-dissipation limits of a given component.

Three basic approaches for enhancing thermal performance are listed below.

- Improving the power dissipation capability of the PCB design
- Improving the thermal coupling of the component to the PCB
- Introducing airflow in the system

The maximum recommended junction temperature (T_J) of the TPS61097A-33 devices is 125°C. Specified regulator operation is assured to a maximum ambient temperature T_A of 85°C. Therefore, the maximum power dissipation is about 191.7 mW. More power can be dissipated if the maximum ambient temperature of the application is lower.

9.2 Typical Application

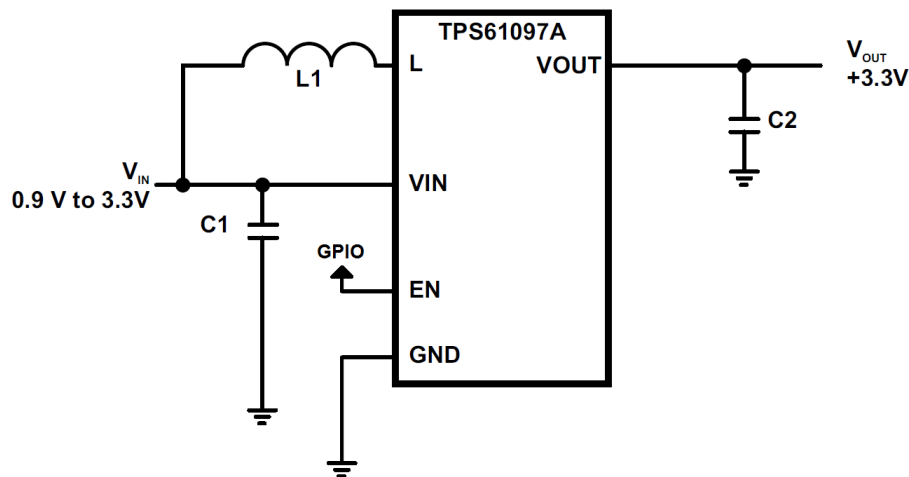

Figure 19. Typical Application Schematic

9.2.1 Design Requirements

DESIGN PARAMETERS	EXAMPLE VALUE
Input Voltage (V_{IN})	1.2 V to 1.8 V
Output Voltage (V_{OUT})	3.3 V
Output Current (I_{OUT})	10 mA

9.2.2 Detailed Design Procedure

9.2.2.1 Inductor Selection

To make sure that the TPS61097A-33 devices can operate, a suitable inductor must be connected between pin VIN and pin L. Inductor values of 4.7 μ H show good performance over the whole input and output voltage range .

Choosing other inductance values affects the switching frequency f proportional to $1/L$ as shown in [Equation 1](#).

$$L = \frac{1}{f \times 200 \text{ mA}} \times \frac{V_{IN} \times (V_{OUT} - V_{IN})}{V_{OUT}} \quad (1)$$

Choosing inductor values higher than 4.7 μH can improve efficiency due to reduced switching frequency and therefore with reduced switching losses. Using inductor values below 2.2 μH is not recommended.

Having selected an inductance value, the peak current for the inductor in steady state operation can be calculated. Equation 2 gives the peak current estimate.

$$I_{L,MAX} = \begin{cases} \frac{V_{OUT} \times I_{OUT}}{0.8 \times V_{IN}} + 100 \text{ mA}; & \text{continuous current operation} \\ 200 \text{ mA}; & \text{discontinuous current operation} \end{cases} \quad (2)$$

$I_{L,MAX}$ is the inductor's required minimum current rating. Note that load transient or over current conditions may require an even higher current rating.

Equation 3 provides an easy way to estimate whether the device is operating in continuous or discontinuous operation. As long as the equation is true, continuous operation is typically established. If the equation becomes false, discontinuous operation is typically established.

$$\frac{V_{OUT} \times I_{OUT}}{V_{IN}} > 0.8 \times 100 \text{ mA} \quad (3)$$

Due to the use of current hysteretic control in the TPS61097A-33, the series resistance of the inductor can impact the operation of the main switch. There is a simple calculation that can ensure proper operation of the TPS61097A-33 boost converter. The relationship between the series resistance (R_{IN}), the input voltage (V_{IN}) and the switch current limit (I_{SW}) is shown in Equation 4.

$$R_{IN} < V_{IN} / I_{SW} \quad (4)$$

Examples:

$$I_{SW} = 400 \text{ mA}, V_{IN} = 2.5 \text{ V} \quad (5)$$

In Equation 5, $R_{IN} < 2.5 \text{ V} / 400 \text{ mA}$; therefore, R_{IN} must be less than 6.25 Ω .

$$I_{SW} = 400 \text{ mA}, V_{IN} = 1.8 \text{ V} \quad (6)$$

In Equation 6, $R_{IN} < 1.8 \text{ V} / 400 \text{ mA}$; therefore, R_{IN} must be less than 4.5 Ω .

The following inductor series from different suppliers have been used with TPS61097A-33 converters:

Table 2. List of Inductors

VENDOR	INDUCTOR SERIES
Coilcraft	DO3314
TDK	NLC565050T
Taiyo Yuden	CBC2012T

9.2.2.2 Capacitor Selection

9.2.2.2.1 Input Capacitor

The input capacitor should be at least 10- μF to improve transient behavior of the regulator and EMI behavior of the total power supply circuit. The input capacitor should be a ceramic capacitor and be placed as close as possible to the VIN and GND pins of the IC.

9.2.2.2.2 Output Capacitor

For the output capacitor C_2 , it is recommended to use small ceramic capacitors placed as close as possible to the VOUT and GND pins of the IC. If, for any reason, the application requires the use of large capacitors which can not be placed close to the IC, the use of a small ceramic capacitor with a capacitance value of around 2.2 μF in parallel to the large one is recommended. This small capacitor should be placed as close as possible to the VOUT and GND pins of the IC.

A minimum capacitance value of 4.7 μF should be used, 10 μF are recommended. If the inductor exceeds 4.7 μH , the value of the output capacitance value needs to be half the inductance value or higher for stability reasons, see Equation 7.

$$C_2 \geq \frac{L}{2} \times \frac{\mu F}{\mu H} \tag{7}$$

Using low ESR capacitors, such as ceramic capacitors, is recommended to minimize output voltage ripple. If heavy load changes are expected, the output capacitor value should be increased to avoid output voltage drops during fast load transients.

Table 3. Recommended Output Capacitors

VENDOR	CAPACITOR SERIES
Murata	GRM188R60J106M47D 10µF 6.3V X5R 0603
Murata	GRM319R61A106KE19 10µF 10V X5R 1206

9.2.3 Application Curves

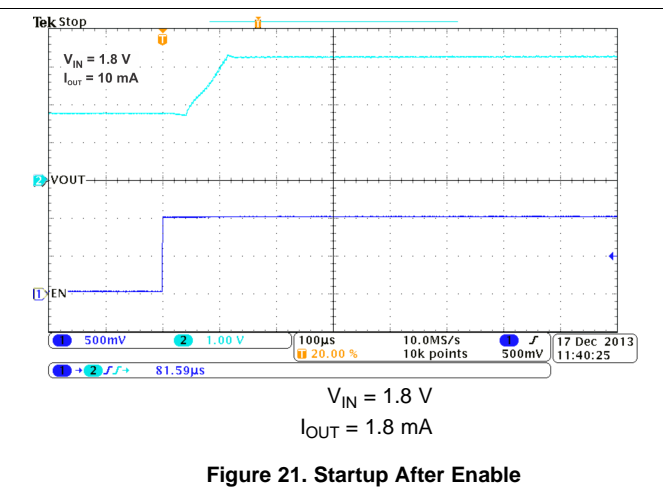
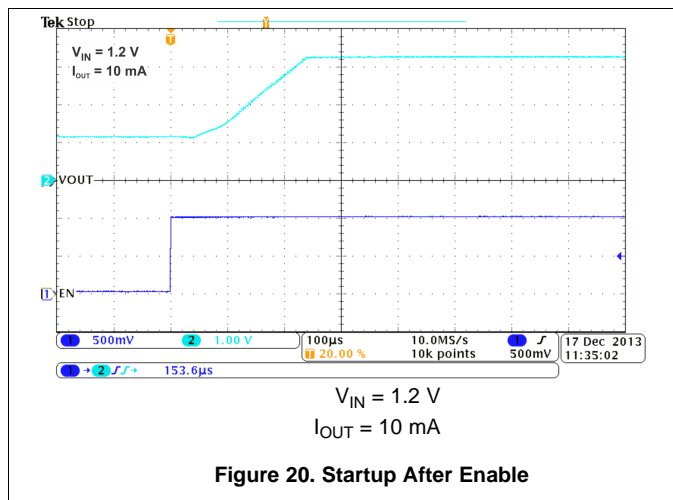

10 Power Supply Recommendations

The TPS61097A-33 DC-DC converters are intended for systems powered by a single up to triple cell Alkaline, NiCd, NiMH battery with a typical terminal voltage between 0.9 V and 5.5 V. They can also be used in systems powered by one-cell Li-Ion or Li-Polymer with a typical voltage between 2.5 V and 4.2 V. Additionally, any other voltage source like solar cells or fuel cells with a typical output voltage between 0.9 V and 5.5 V can power systems where the TPS61097A-33 is used. The TPS61097A-33 does not down-regulate V_{IN} ; therefore, if V_{IN} is greater than V_{OUT} , V_{OUT} tracks V_{IN} .

11 Layout

11.1 Layout Guidelines

As for all switching power supplies, the layout is an important step in the design, especially at high peak currents and high switching frequencies. If the layout is not carefully done, the regulator could show stability problems as well as EMI problems. Therefore, use wide and short traces for the main current path and for the power ground tracks. The input and output capacitor, as well as the inductor should be placed as close as possible to the IC. Use a common ground node for power ground and a different one for control ground to minimize the effects of ground noise. Connect these ground nodes at any place close to one of the ground pins of the IC.

The feedback divider should be placed as close as possible to the control ground pin of the IC. To lay out the control ground, it is recommended to use short traces as well, separated from the power ground traces. This avoids ground shift problems, which can occur due to superimposition of power ground current and control ground current.

11.2 Layout Example

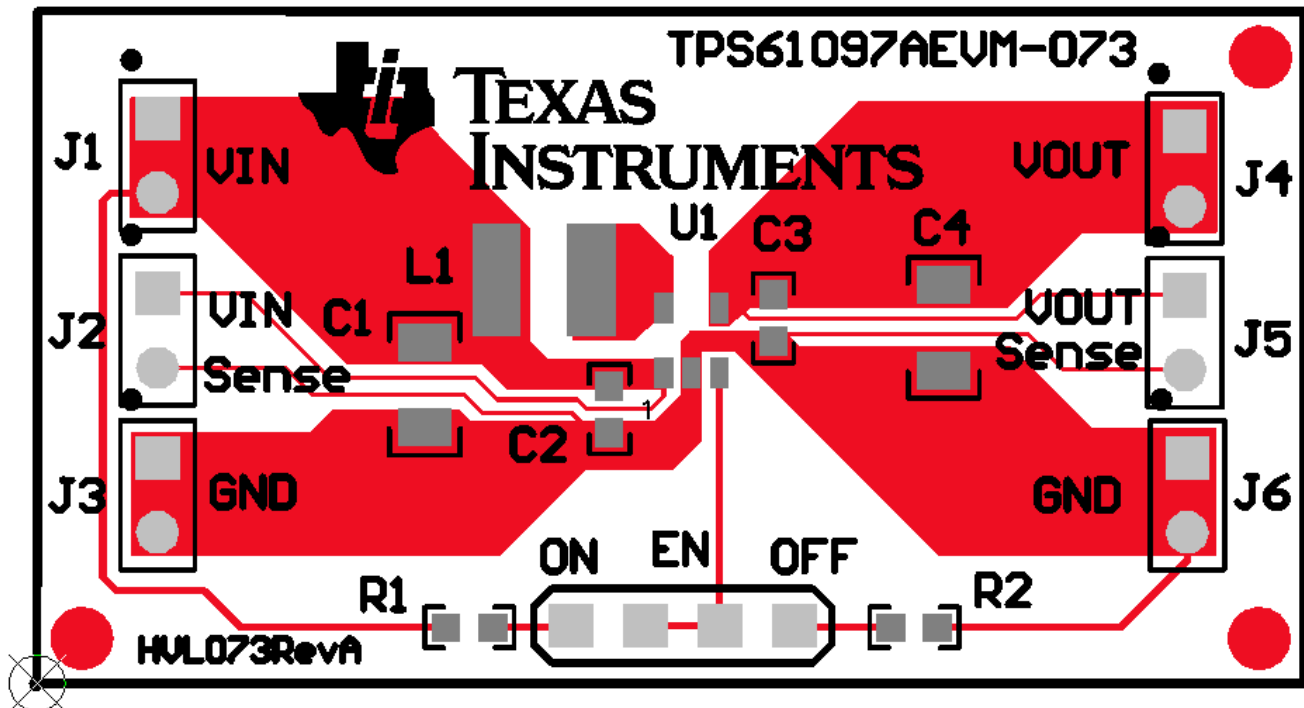

Figure 22. Layout Example

12 Device and Documentation Support

12.1 Device Support

12.1.1 Third-Party Products Disclaimer

TI'S PUBLICATION OF INFORMATION REGARDING THIRD-PARTY PRODUCTS OR SERVICES DOES NOT CONSTITUTE AN ENDORSEMENT REGARDING THE SUITABILITY OF SUCH PRODUCTS OR SERVICES OR A WARRANTY, REPRESENTATION OR ENDORSEMENT OF SUCH PRODUCTS OR SERVICES, EITHER ALONE OR IN COMBINATION WITH ANY TI PRODUCT OR SERVICE.

12.2 Trademarks

All trademarks are the property of their respective owners.

12.3 Electrostatic Discharge Caution



These devices have limited built-in ESD protection. The leads should be shorted together or the device placed in conductive foam during storage or handling to prevent electrostatic damage to the MOS gates.

12.4 Glossary

[SLYZ022](#) — *TI Glossary*.

This glossary lists and explains terms, acronyms, and definitions.

13 Mechanical, Packaging, and Orderable Information

The following pages include mechanical, packaging, and orderable information. This information is the most current data available for the designated devices. This data is subject to change without notice and revision of this document. For browser-based versions of this data sheet, refer to the left-hand navigation.

PACKAGING INFORMATION

Orderable Device	Status (1)	Package Type	Package Drawing	Pins	Package Qty	Eco Plan (2)	Lead finish/ Ball material (6)	MSL Peak Temp (3)	Op Temp (°C)	Device Marking (4/5)	Samples
TPS61097A-33DBVR	ACTIVE	SOT-23	DBV	5	3000	RoHS & Green	NIPDAU SN	Level-1-260C-UNLIM	-40 to 125	(NG5F, NG5K)	Samples
TPS61097A-33DBVT	ACTIVE	SOT-23	DBV	5	250	RoHS & Green	NIPDAU	Level-1-260C-UNLIM	-40 to 125	NG5K	Samples

(1) The marketing status values are defined as follows:

ACTIVE: Product device recommended for new designs.

LIFEBUY: TI has announced that the device will be discontinued, and a lifetime-buy period is in effect.

NRND: Not recommended for new designs. Device is in production to support existing customers, but TI does not recommend using this part in a new design.

PREVIEW: Device has been announced but is not in production. Samples may or may not be available.

OBSOLETE: TI has discontinued the production of the device.

(2) **RoHS:** TI defines "RoHS" to mean semiconductor products that are compliant with the current EU RoHS requirements for all 10 RoHS substances, including the requirement that RoHS substance do not exceed 0.1% by weight in homogeneous materials. Where designed to be soldered at high temperatures, "RoHS" products are suitable for use in specified lead-free processes. TI may reference these types of products as "Pb-Free".

RoHS Exempt: TI defines "RoHS Exempt" to mean products that contain lead but are compliant with EU RoHS pursuant to a specific EU RoHS exemption.

Green: TI defines "Green" to mean the content of Chlorine (Cl) and Bromine (Br) based flame retardants meet JS709B low halogen requirements of <=1000ppm threshold. Antimony trioxide based flame retardants must also meet the <=1000ppm threshold requirement.

(3) MSL, Peak Temp. - The Moisture Sensitivity Level rating according to the JEDEC industry standard classifications, and peak solder temperature.

(4) There may be additional marking, which relates to the logo, the lot trace code information, or the environmental category on the device.

(5) Multiple Device Markings will be inside parentheses. Only one Device Marking contained in parentheses and separated by a "~" will appear on a device. If a line is indented then it is a continuation of the previous line and the two combined represent the entire Device Marking for that device.

(6) Lead finish/Ball material - Orderable Devices may have multiple material finish options. Finish options are separated by a vertical ruled line. Lead finish/Ball material values may wrap to two lines if the finish value exceeds the maximum column width.

Important Information and Disclaimer:The information provided on this page represents TI's knowledge and belief as of the date that it is provided. TI bases its knowledge and belief on information provided by third parties, and makes no representation or warranty as to the accuracy of such information. Efforts are underway to better integrate information from third parties. TI has taken and continues to take reasonable steps to provide representative and accurate information but may not have conducted destructive testing or chemical analysis on incoming materials and chemicals. TI and TI suppliers consider certain information to be proprietary, and thus CAS numbers and other limited information may not be available for release.

In no event shall TI's liability arising out of such information exceed the total purchase price of the TI part(s) at issue in this document sold by TI to Customer on an annual basis.

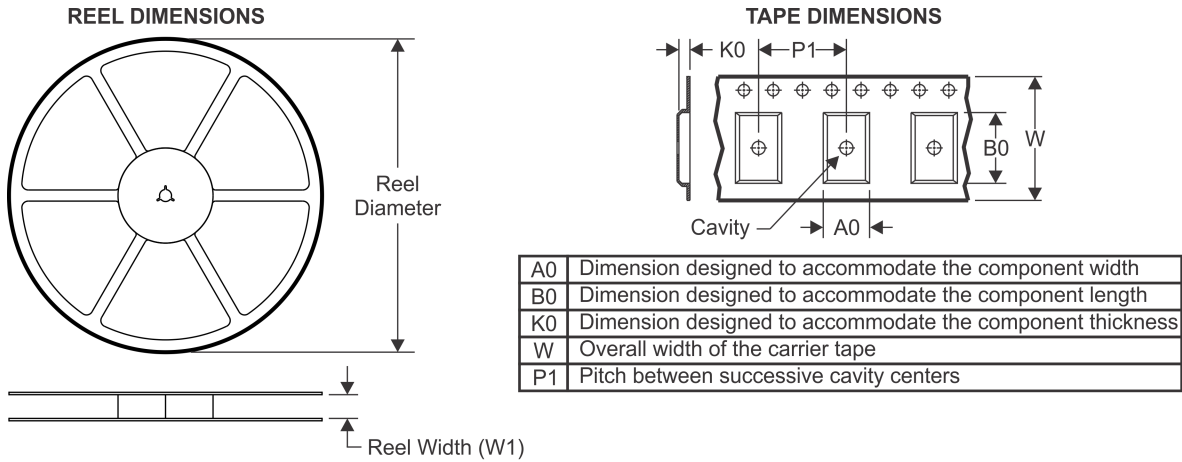
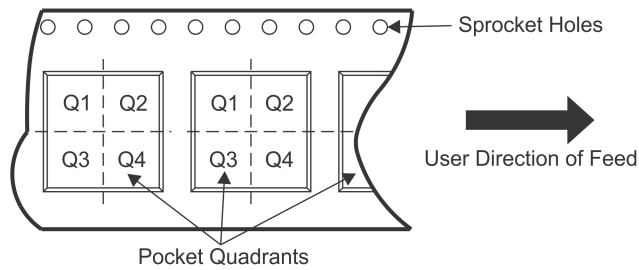
TAPE AND REEL INFORMATION

QUADRANT ASSIGNMENTS FOR PIN 1 ORIENTATION IN TAPE

*All dimensions are nominal

Device	Package Type	Package Drawing	Pins	SPQ	Reel Diameter (mm)	Reel Width W1 (mm)	A0 (mm)	B0 (mm)	K0 (mm)	P1 (mm)	W (mm)	Pin1 Quadrant
TPS61097A-33DBVT	SOT-23	DBV	5	250	180.0	8.4	3.23	3.17	1.37	4.0	8.0	Q3

TAPE AND REEL BOX DIMENSIONS

*All dimensions are nominal

Device	Package Type	Package Drawing	Pins	SPQ	Length (mm)	Width (mm)	Height (mm)
TPS61097A-33DBVT	SOT-23	DBV	5	250	183.0	183.0	20.0

DBV0005A



PACKAGE OUTLINE

SOT-23 - 1.45 mm max height

SMALL OUTLINE TRANSISTOR

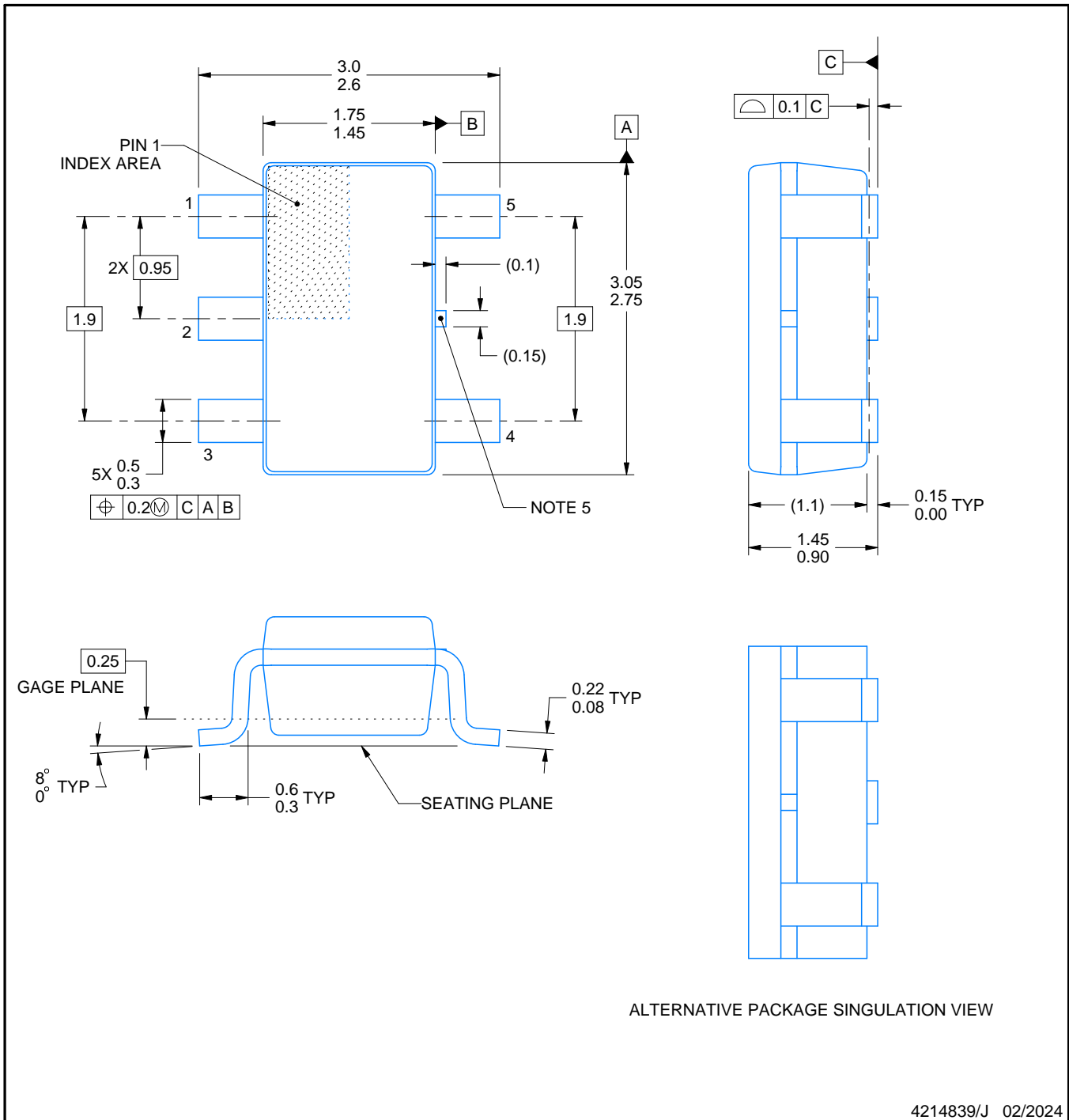

NOTES:

1. All linear dimensions are in millimeters. Any dimensions in parenthesis are for reference only. Dimensioning and tolerancing per ASME Y14.5M.
2. This drawing is subject to change without notice.
3. Reference JEDEC MO-178.
4. Body dimensions do not include mold flash, protrusions, or gate burrs. Mold flash, protrusions, or gate burrs shall not exceed 0.25 mm per side.
5. Support pin may differ or may not be present.

EXAMPLE BOARD LAYOUT

DBV0005A

SOT-23 - 1.45 mm max height

SMALL OUTLINE TRANSISTOR



LAND PATTERN EXAMPLE
EXPOSED METAL SHOWN
SCALE:15X



SOLDER MASK DETAILS

4214839/J 02/2024

NOTES: (continued)

- 6. Publication IPC-7351 may have alternate designs.
- 7. Solder mask tolerances between and around signal pads can vary based on board fabrication site.

EXAMPLE STENCIL DESIGN

DBV0005A

SOT-23 - 1.45 mm max height

SMALL OUTLINE TRANSISTOR



SOLDER PASTE EXAMPLE
BASED ON 0.125 mm THICK STENCIL
SCALE:15X

4214839/J 02/2024

NOTES: (continued)

8. Laser cutting apertures with trapezoidal walls and rounded corners may offer better paste release. IPC-7525 may have alternate design recommendations.
9. Board assembly site may have different recommendations for stencil design.

IMPORTANT NOTICE AND DISCLAIMER

TI PROVIDES TECHNICAL AND RELIABILITY DATA (INCLUDING DATA SHEETS), DESIGN RESOURCES (INCLUDING REFERENCE DESIGNS), APPLICATION OR OTHER DESIGN ADVICE, WEB TOOLS, SAFETY INFORMATION, AND OTHER RESOURCES "AS IS" AND WITH ALL FAULTS, AND DISCLAIMS ALL WARRANTIES, EXPRESS AND IMPLIED, INCLUDING WITHOUT LIMITATION ANY IMPLIED WARRANTIES OF MERCHANTABILITY, FITNESS FOR A PARTICULAR PURPOSE OR NON-INFRINGEMENT OF THIRD PARTY INTELLECTUAL PROPERTY RIGHTS.

These resources are intended for skilled developers designing with TI products. You are solely responsible for (1) selecting the appropriate TI products for your application, (2) designing, validating and testing your application, and (3) ensuring your application meets applicable standards, and any other safety, security, regulatory or other requirements.

These resources are subject to change without notice. TI grants you permission to use these resources only for development of an application that uses the TI products described in the resource. Other reproduction and display of these resources is prohibited. No license is granted to any other TI intellectual property right or to any third party intellectual property right. TI disclaims responsibility for, and you will fully indemnify TI and its representatives against, any claims, damages, costs, losses, and liabilities arising out of your use of these resources.

TI's products are provided subject to [TI's Terms of Sale](#) or other applicable terms available either on [ti.com](https://www.ti.com) or provided in conjunction with such TI products. TI's provision of these resources does not expand or otherwise alter TI's applicable warranties or warranty disclaimers for TI products.

TI objects to and rejects any additional or different terms you may have proposed.

Mailing Address: Texas Instruments, Post Office Box 655303, Dallas, Texas 75265
Copyright © 2024, Texas Instruments Incorporated

Looking for pricing, stock, or lifecycle information?

Click below to explore more details on WIN SOURCE:

 [View IPD95R450P7ATMA1 on WIN SOURCE](#)

 [Infineon Technologies](#) Information

Optimize Your Supply Chain with WIN SOURCE Solutions

-  Global Sourcing Solution
-  Obsolete Management
-  Cost Control Management
-  Shortage Management
-  Alternative Solution
-  Excess Inventory Management