



**THE DATASHEET OF  
TL2217-285PWR**



- Fully Matches Parameters for SCSI Alternative 2 Active Termination
- Fixed 2.85-V Output
- $\pm 1.5\%$  Maximum Output Tolerance at  $T_J = 25^\circ\text{C}$
- 1-V Maximum Dropout Voltage
- 500-mA Output Current
- $\pm 3\%$  Absolute Output Variation
- Internal Overcurrent-Limiting Circuitry
- Internal Thermal-Overload Protection
- Internal Overvoltage Protection

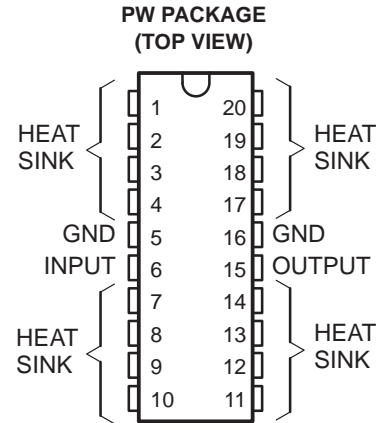
**description**

The TL2217-285 is a low-dropout (1 V) fixed-voltage regulator specifically designed for small computer systems interface (SCSI) alternative 2 active signal termination. The TL2217-285 1-V maximum dropout ensures compatibility with existing SCSI systems, while providing a wide TERMPWR voltage range. At the same time, the  $\pm 1.5\%$  initial tolerance on its 2.85-V output voltage ensures a tighter line-driver current tolerance, thereby increasing system noise margin.

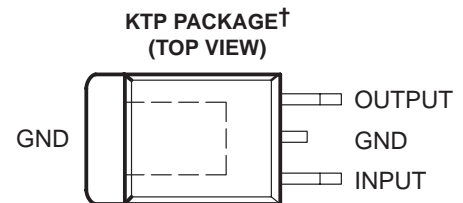
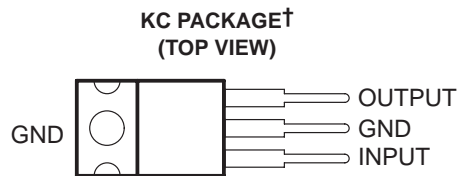
The fixed 2.85-V output voltage of TL2217-285 supports the SCSI alternative 2 termination standard, while reducing system power consumption. The 1-V maximum dropout voltage brings increased TERMPWR isolation, making the device ideal for battery-powered systems. The TL2217-285, with internal current limiting, overvoltage protection, ESD protection, and thermal protection, offers designers enhanced system protection and reliability.

When configured as a SCSI active terminator, the TL2217-285 low-dropout regulator eliminates the 220- $\Omega$  and 330- $\Omega$  resistors required for each transmission line with a passive termination scheme, reducing significantly the continuous system-power drain. When placed in series with 110- $\Omega$  resistors, the device matches the impedance level of the transmission cable and eliminates reflections.

The TL2217-285 is characterized for operation over the virtual junction temperature range of 0°C to 125°C.



HEAT SINK – These pins have an internal resistive connection to ground and should be grounded or electrically isolated.



† The GND terminal is in electrical contact with the mounting base.



Please be aware that an important notice concerning availability, standard warranty, and use in critical applications of Texas Instruments semiconductor products and disclaimers thereto appears at the end of this data sheet.

PRODUCTION DATA information is current as of publication date. Products conform to specifications per the terms of Texas Instruments standard warranty. Production processing does not necessarily include testing of all parameters.





**electrical characteristics over recommended operating conditions,  $V_I = 4.5\text{ V}$ ,  $I_O = 500\text{ mA}$ ,  $T_J = 25^\circ\text{C}$   
 (unless otherwise noted)**

| PARAMETER                 | TEST CONDITIONST  | TL2217-285                                   |       |      | UNIT          |   |
|---------------------------|---|--|-------|------|---------------|---|
|                           |   | MIN  | TYP   | MAX  |               |   |
| Output voltage            | $I_O = 20\text{ mA to }500\text{ mA}$ , $V_I = 3.85\text{ V to }5.5\text{ V}$ | $T_J = 25^\circ\text{C}$                     | 2.81  | 2.85 | 2.89          | V |
|                           |   | $T_J = 0^\circ\text{C to }125^\circ\text{C}$ | 2.765 |      | 2.935         |   |
| Input voltage regulation  | $V_I = 3.85\text{ V to }5.5\text{ V}$   |  | 5     | 15   | mV            |   |
| Ripple rejection          | $f = 120\text{ Hz}$ , $V_{\text{ripple}} = 1\text{ V}_{\text{PP}}$            |  | -62   |      | dB            |   |
| Output voltage regulation | $I_O = 20\text{ mA to }500\text{ mA}$   |  | 5     | 30   | mV            |   |
| Output noise voltage      | $f = 10\text{ Hz to }100\text{ kHz}$  |  | 500   |      | $\mu\text{V}$ |   |
| Dropout voltage           |   |  |       | 1    | V             |   |
| Bias current              | $I_O = 0$   |  | 2     | 5    | mA            |   |
|                           | $I_O = 27\text{ mA}$ , equivalent 1 line asserted                             |  | 3     | 6    |               |   |
|                           | $I_O = 500\text{ mA}$ , equivalent 18 lines asserted (8 bit)                  |  | 26    | 49   |               |   |

† Pulse-testing techniques are used to maintain the virtual junction temperature as close to the ambient temperature as possible. Thermal effects must be taken into account separately. All characteristics are measured with a 0.1- $\mu\text{F}$  capacitor across the input and a 22- $\mu\text{F}$  tantalum capacitor with equivalent series resistance of 1.5  $\Omega$  on the output.

**electrical characteristics over recommended operating conditions,  $V_I = 4.5\text{ V}$ ,  $I_O = 500\text{ mA}$ ,  $T_J = 25^\circ\text{C}$   
 (unless otherwise noted)**

| PARAMETER                 | TEST CONDITIONST  | TL2217-285Y |      |      | UNIT          |
|---------------------------|---|-------------|------|------|---------------|
|                           |   | MIN         | TYP  | MAX  |               |
| Output voltage            | $I_O = 20\text{ mA to }500\text{ mA}$ , $V_I = 3.85\text{ V to }5.5\text{ V}$ | 2.81        | 2.85 | 2.89 | V             |
| Input voltage regulation  | $V_I = 3.85\text{ V to }5.5\text{ V}$   |             | 5    | 15   | mV            |
| Ripple rejection          | $f = 120\text{ Hz}$ , $V_{\text{ripple}} = 1\text{ V}_{\text{PP}}$            |             | -62  |      | dB            |
| Output voltage regulation | $I_O = 20\text{ mA to }500\text{ mA}$   |             | 5    | 30   | mV            |
| Output noise voltage      | $f = 10\text{ Hz to }100\text{ kHz}$  |             | 500  |      | $\mu\text{V}$ |
| Dropout voltage           | $I_O = 500\text{ mA}$   |             |      | 1    | V             |
| Bias current              | $I_O = 0$   |             | 2    | 5    | mA            |
|                           | $I_O = 27\text{ mA}$ , equivalent 1 line asserted                             |             | 3    | 6    |               |
|                           | $I_O = 500\text{ mA}$ , equivalent 18 lines asserted (8 bit)                  |             | 26   | 49   |               |

† Pulse-testing techniques are used to maintain the virtual junction temperature as close to the ambient temperature as possible. Thermal effects must be taken into account separately. All characteristics are measured with a 0.1- $\mu\text{F}$  capacitor across the input and a 22- $\mu\text{F}$  tantalum capacitor with equivalent series resistance of 1.5  $\Omega$  on the output.

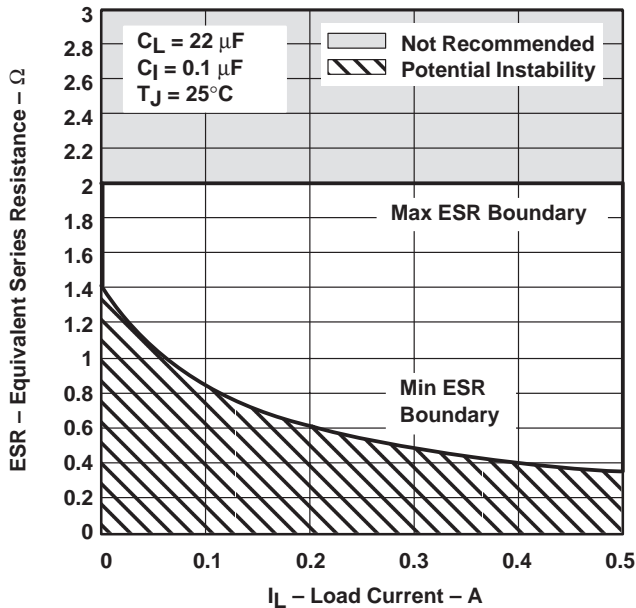
**TL2217-285  
FIXED-VOLTAGE REGULATORS  
FOR SCSI ACTIVE TERMINATION**

SLVS066F – NOVEMBER 1991 – REVISED JULY 1999

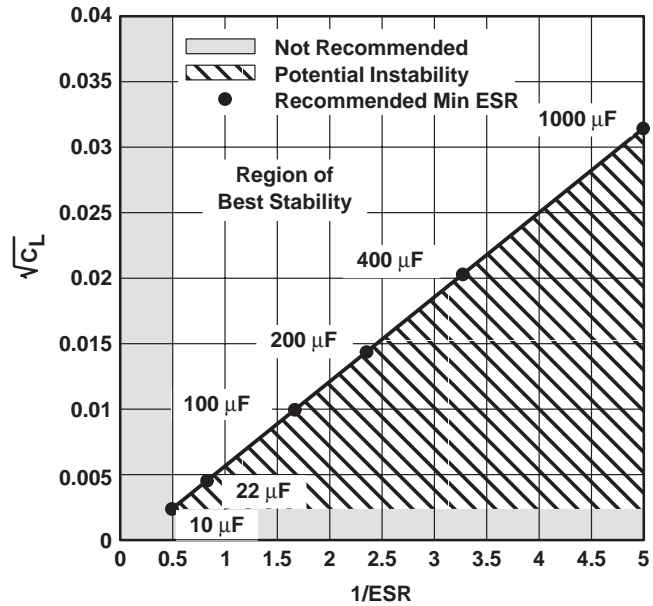
**COMPENSATION-CAPACITOR SELECTION INFORMATION**

The TL2217-285 is a low-dropout regulator. This means that the capacitance loading is important to the performance of the regulator because it is a vital part of the control loop. The capacitor value and the equivalent series resistance (ESR) both affect the control loop and must be defined for the load range and the temperature range. Figure 3 and Figure 4 can be used to establish the capacitance value and ESR range for best regulator performance.

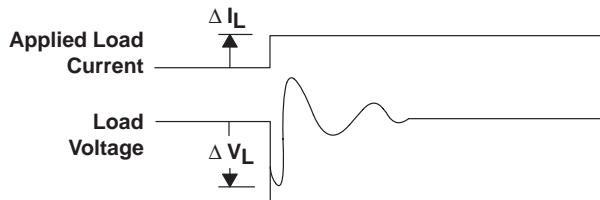
**ESR (OUTPUT CAPACITOR)  
vs  
LOAD CURRENT**



**STABILITY  
vs  
ESR**

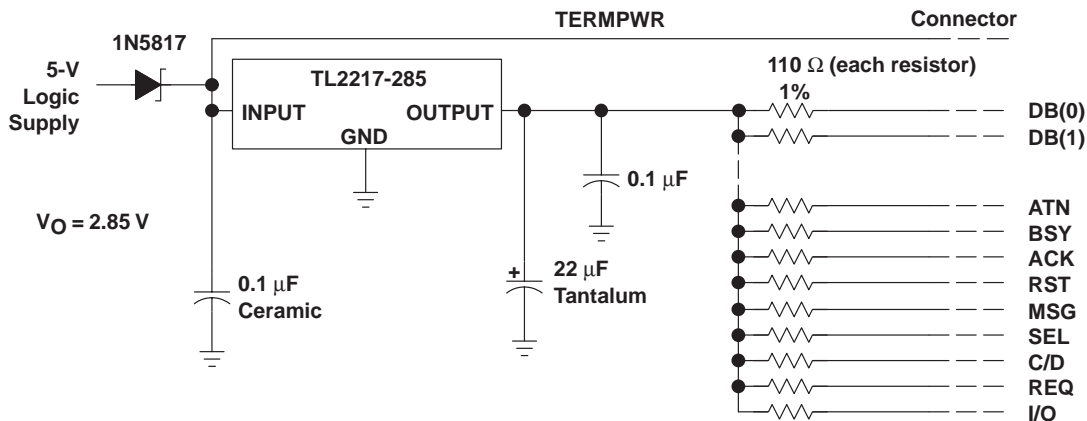


**Figure 2**



**Figure 1**

**APPLICATION INFORMATION**



**Figure 3. Typical Application Schematic**

**PACKAGING INFORMATION**

| Orderable Device | Status <sup>(1)</sup> | Package Type | Package Drawing | Pins | Package Qty | Eco Plan <sup>(2)</sup> | Lead/Ball Finish | MSL Peak Temp <sup>(3)</sup> |
|------------------|-----------------------|--------------|-----------------|------|-------------|-------------------------|------------------|------------------------------|
| TL2217-285KC     | OBSOLETE              | TO-220       | KC              | 3    |             | TBD                     | Call TI          | Call TI                      |
| TL2217-285PWR    | OBSOLETE              | TSSOP        | PW              | 20   |             | TBD                     | Call TI          | Call TI                      |

<sup>(1)</sup> The marketing status values are defined as follows:

**ACTIVE:** Product device recommended for new designs.

**LIFEBUY:** TI has announced that the device will be discontinued, and a lifetime-buy period is in effect.

**NRND:** Not recommended for new designs. Device is in production to support existing customers, but TI does not recommend using this part in a new design.

**PREVIEW:** Device has been announced but is not in production. Samples may or may not be available.

**OBSOLETE:** TI has discontinued the production of the device.

<sup>(2)</sup> Eco Plan - The planned eco-friendly classification: Pb-Free (RoHS) or Green (RoHS & no Sb/Br) - please check <http://www.ti.com/productcontent> for the latest availability information and additional product content details.

**TBD:** The Pb-Free/Green conversion plan has not been defined.

**Pb-Free (RoHS):** TI's terms "Lead-Free" or "Pb-Free" mean semiconductor products that are compatible with the current RoHS requirements for all 6 substances, including the requirement that lead not exceed 0.1% by weight in homogeneous materials. Where designed to be soldered at high temperatures, TI Pb-Free products are suitable for use in specified lead-free processes.

**Green (RoHS & no Sb/Br):** TI defines "Green" to mean Pb-Free (RoHS compatible), and free of Bromine (Br) and Antimony (Sb) based flame retardants (Br or Sb do not exceed 0.1% by weight in homogeneous material)

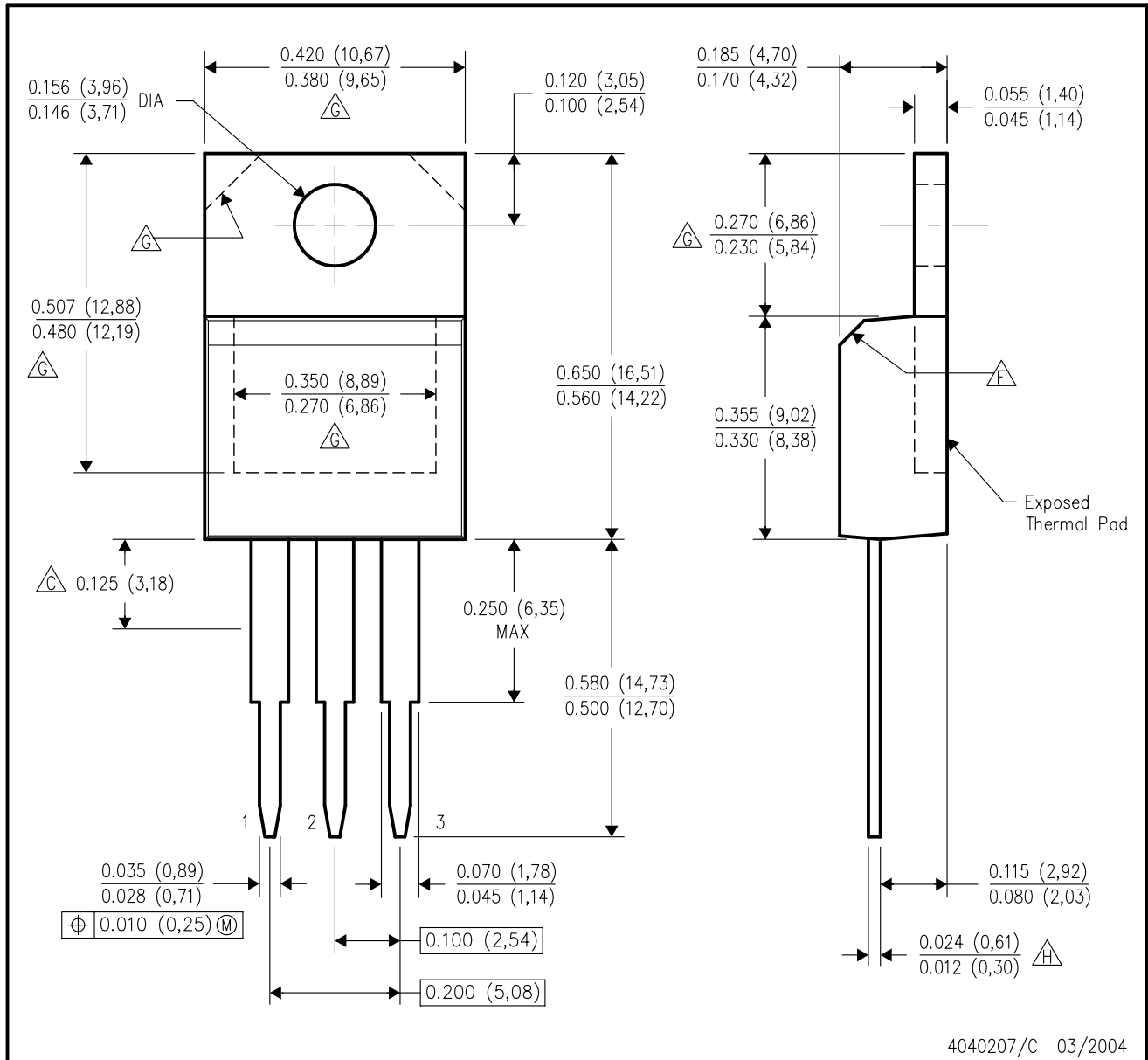
<sup>(3)</sup> MSL, Peak Temp. -- The Moisture Sensitivity Level rating according to the JEDEC industry standard classifications, and peak solder temperature.

**Important Information and Disclaimer:**The information provided on this page represents TI's knowledge and belief as of the date that it is provided. TI bases its knowledge and belief on information provided by third parties, and makes no representation or warranty as to the accuracy of such information. Efforts are underway to better integrate information from third parties. TI has taken and continues to take reasonable steps to provide representative and accurate information but may not have conducted destructive testing or chemical analysis on incoming materials and chemicals. TI and TI suppliers consider certain information to be proprietary, and thus CAS numbers and other limited information may not be available for release.

In no event shall TI's liability arising out of such information exceed the total purchase price of the TI part(s) at issue in this document sold by TI to Customer on an annual basis.

KC (R-PSFM-T3)

PLASTIC FLANGE-MOUNT PACKAGE



- NOTES:
- A. All linear dimensions are in inches (millimeters).
  - B. This drawing is subject to change without notice.
  - C. Lead dimensions are not controlled within this area.
  - D. All lead dimensions apply before solder dip.
  - E. The center lead is in electrical contact with the mounting tab.
  - F. The chamfer is optional.
  - G. Thermal pad contour optional within these dimensions.
  - H. Falls within JEDEC TO-220 variation AB, except minimum lead thickness.

PW (R-PDSO-G\*\*)

PLASTIC SMALL-OUTLINE PACKAGE

14 PINS SHOWN



4040064/F 01/97

- NOTES: A. All linear dimensions are in millimeters.  
 B. This drawing is subject to change without notice.  
 C. Body dimensions do not include mold flash or protrusion not to exceed 0,15.  
 D. Falls within JEDEC MO-153

## IMPORTANT NOTICE

Texas Instruments Incorporated and its subsidiaries (TI) reserve the right to make corrections, modifications, enhancements, improvements, and other changes to its products and services at any time and to discontinue any product or service without notice. Customers should obtain the latest relevant information before placing orders and should verify that such information is current and complete. All products are sold subject to TI's terms and conditions of sale supplied at the time of order acknowledgment.

TI warrants performance of its hardware products to the specifications applicable at the time of sale in accordance with TI's standard warranty. Testing and other quality control techniques are used to the extent TI deems necessary to support this warranty. Except where mandated by government requirements, testing of all parameters of each product is not necessarily performed.

TI assumes no liability for applications assistance or customer product design. Customers are responsible for their products and applications using TI components. To minimize the risks associated with customer products and applications, customers should provide adequate design and operating safeguards.

TI does not warrant or represent that any license, either express or implied, is granted under any TI patent right, copyright, mask work right, or other TI intellectual property right relating to any combination, machine, or process in which TI products or services are used. Information published by TI regarding third-party products or services does not constitute a license from TI to use such products or services or a warranty or endorsement thereof. Use of such information may require a license from a third party under the patents or other intellectual property of the third party, or a license from TI under the patents or other intellectual property of TI.

Reproduction of information in TI data books or data sheets is permissible only if reproduction is without alteration and is accompanied by all associated warranties, conditions, limitations, and notices. Reproduction of this information with alteration is an unfair and deceptive business practice. TI is not responsible or liable for such altered documentation.

Resale of TI products or services with statements different from or beyond the parameters stated by TI for that product or service voids all express and any implied warranties for the associated TI product or service and is an unfair and deceptive business practice. TI is not responsible or liable for any such statements.

Following are URLs where you can obtain information on other Texas Instruments products and application solutions:

| <b>Products</b>  |  | <b>Applications</b> |  |
|------------------|--|---------------------|--|
| Amplifiers       | <a href="http://amplifier.ti.com">amplifier.ti.com</a>             | Audio               | <a href="http://www.ti.com/audio">www.ti.com/audio</a>                   |
| Data Converters  | <a href="http://dataconverter.ti.com">dataconverter.ti.com</a>     | Automotive          | <a href="http://www.ti.com/automotive">www.ti.com/automotive</a>         |
| DSP              | <a href="http://dsp.ti.com">dsp.ti.com</a>                         | Broadband           | <a href="http://www.ti.com/broadband">www.ti.com/broadband</a>           |
| Interface        | <a href="http://interface.ti.com">interface.ti.com</a>             | Digital Control     | <a href="http://www.ti.com/digitalcontrol">www.ti.com/digitalcontrol</a> |
| Logic            | <a href="http://logic.ti.com">logic.ti.com</a>                     | Military            | <a href="http://www.ti.com/military">www.ti.com/military</a>             |
| Power Mgmt       | <a href="http://power.ti.com">power.ti.com</a>                     | Optical Networking  | <a href="http://www.ti.com/opticalnetwork">www.ti.com/opticalnetwork</a> |
| Microcontrollers | <a href="http://microcontroller.ti.com">microcontroller.ti.com</a> | Security            | <a href="http://www.ti.com/security">www.ti.com/security</a>             |
|                  |  | Telephony           | <a href="http://www.ti.com/telephony">www.ti.com/telephony</a>           |
|                  |  | Video & Imaging     | <a href="http://www.ti.com/video">www.ti.com/video</a>                   |
|                  |  | Wireless            | <a href="http://www.ti.com/wireless">www.ti.com/wireless</a>             |

Mailing Address: Texas Instruments  
Post Office Box 655303 Dallas, Texas 75265

## Looking for pricing, stock, or lifecycle information?

Click below to explore more details on WIN SOURCE:

 [View TL2217-285PWR on WIN SOURCE](#)

 [Texas Instruments](#) Information

## Optimize Your Supply Chain with WIN SOURCE Solutions

-  Global Sourcing Solution
-  Obsolete Management
-  Cost Control Management
-  Shortage Management
-  Alternative Solution
-  Excess Inventory Management