



**THE DATASHEET OF  
TLE5009E1010FUMA1**



# Angle Sensor

GMR-Based Angular Sensor

## TLE5009

TLE5009-E2000  
TLE5009-E1000  
TLE5009-E2010  
TLE5009-E1010

## Data Sheet

Rev. 1.1, 2012-04

**Edition 2012-04**

**Published by  
Infineon Technologies AG  
81726 Munich, Germany**

**© 2012 Infineon Technologies AG  
All Rights Reserved.**

### **Legal Disclaimer**

The information given in this document shall in no event be regarded as a guarantee of conditions or characteristics. With respect to any examples or hints given herein, any typical values stated herein and/or any information regarding the application of the device, Infineon Technologies hereby disclaims any and all warranties and liabilities of any kind, including without limitation, warranties of non-infringement of intellectual property rights of any third party.

### **Information**

For further information on technology, delivery terms and conditions and prices, please contact the nearest Infineon Technologies Office ([www.infineon.com](http://www.infineon.com)).

### **Warnings**

Due to technical requirements, components may contain dangerous substances. For information on the types in question, please contact the nearest Infineon Technologies Office.

Infineon Technologies components may be used in life-support devices or systems only with the express written approval of Infineon Technologies, if a failure of such components can reasonably be expected to cause the failure of that life-support device or system or to affect the safety or effectiveness of that device or system. Life support devices or systems are intended to be implanted in the human body or to support and/or maintain and sustain and/or protect human life. If they fail, it is reasonable to assume that the health of the user or other persons may be endangered.

Revision History	
Changes	Subjects (changes since revision 1.0)
<a href="#">Chapter 3.3</a>	Inserted magnetic field definition
<a href="#">Chapter 3.4.3</a>	Updated parameter X,Y amplitude
<a href="#">Chapter 3.4.4</a>	Inserted calibration information for definition of overall angle error
<a href="#">Chapter 3.4.5</a>	Updated information of overall angle error, product types included: TLE5009-E2010, TLE5009-E1010
<a href="#">Chapter 3.5.2</a>	Inserted information on external safety checks, differential vector length check

**Trademarks of Infineon Technologies AG**

AURIX™, C166™, CanPAK™, CIPOS™, CIPURSE™, EconoPACK™, CoolMOS™, CoolSET™, CORECONTROL™, CROSSAVE™, DAVE™, EasyPIM™, EconoBRIDGE™, EconoDUAL™, EconoPIM™, EiceDRIVER™, eupec™, FCOS™, HITFET™, HybridPACK™, I<sup>2</sup>RF™, ISOFACE™, IsoPACK™, MIPAQ™, ModSTACK™, my-d™, NovalithIC™, OptiMOS™, ORIGA™, PRIMARION™, PrimePACK™, PrimeSTACK™, PRO-SIL™, PROFET™, RASIC™, ReverSave™, SatRIC™, SIEGET™, SINDRION™, SIPMOS™, SmartLEWIS™, SOLID FLASH™, TEMPFET™, thinQ!™, TRENCHSTOP™, TriCore™.

**Other Trademarks**

Advance Design System™ (ADS) of Agilent Technologies, AMBA™, ARM™, MULTI-ICE™, KEIL™, PRIMECELL™, REALVIEW™, THUMB™, µVision™ of ARM Limited, UK. AUTOSAR™ is licensed by AUTOSAR development partnership. Bluetooth™ of Bluetooth SIG Inc. CAT-iq™ of DECT Forum. COLOSSUS™, FirstGPS™ of Trimble Navigation Ltd. EMV™ of EMVCo, LLC (Visa Holdings Inc.). EPCOS™ of Epcos AG. FLEXGO™ of Microsoft Corporation. FlexRay™ is licensed by FlexRay Consortium. HYPERTERMINAL™ of Hilgraeve Incorporated. IEC™ of Commission Electrotechnique Internationale. IrDA™ of Infrared Data Association Corporation. ISO™ of INTERNATIONAL ORGANIZATION FOR STANDARDIZATION. MATLAB™ of MathWorks, Inc. MAXIM™ of Maxim Integrated Products, Inc. MICROTEC™, NUCLEUS™ of Mentor Graphics Corporation. Mifare™ of NXP. MIPI™ of MIPI Alliance, Inc. MIPS™ of MIPS Technologies, Inc., USA. muRata™ of MURATA MANUFACTURING CO., MICROWAVE OFFICE™ (MWO) of Applied Wave Research Inc., OmniVision™ of OmniVision Technologies, Inc. Openwave™ Openwave Systems Inc. RED HAT™ Red Hat, Inc. RFMD™ RF Micro Devices, Inc. SIRIUS™ of Sirius Satellite Radio Inc. SOLARIS™ of Sun Microsystems, Inc. SPANSION™ of Spansion LLC Ltd. Symbian™ of Symbian Software Limited. TAIYO YUDEN™ of Taiyo Yuden Co. TEAKLITE™ of CEVA, Inc. TEKTRONIX™ of Tektronix Inc. TOKO™ of TOKO KABUSHIKI KAISHA TA. UNIX™ of X/Open Company Limited. VERILOG™, PALLADIUM™ of Cadence Design Systems, Inc. VLYNQ™ of Texas Instruments Incorporated. VXWORKS™, WIND RIVER™ of WIND RIVER SYSTEMS, INC. ZETEX™ of Diodes Zetex Limited.

Last Trademarks Update 2011-02-24

## Table of Contents

	<b>Table of Contents</b> .....	4
	<b>List of Figures</b> .....	5
	<b>List of Tables</b> .....	6
<b>1</b>	<b>Product Description</b> .....	7
1.1	Overview .....	7
1.2	Features .....	7
1.3	Target Applications .....	7
<b>2</b>	<b>Functional Description</b> .....	8
2.1	General .....	8
2.2	Pin Configuration .....	10
2.3	Pin Description .....	10
2.4	Block Diagram .....	11
<b>3</b>	<b>Specification</b> .....	12
3.1	Application Circuit .....	12
3.2	Absolute Maximum Ratings .....	12
3.3	Operating Range .....	13
3.4	Characteristics .....	15
3.4.1	Electrical Parameters .....	15
3.4.2	Electrostatic discharge protection .....	15
3.4.3	Output Parameters .....	16
3.4.4	Calibration of TLE5009 .....	19
3.4.4.1	Extraction of Parameters .....	19
3.4.4.1.1	Min-Max Method .....	19
3.4.4.1.2	Exact Method .....	22
3.4.4.2	Final Parameters .....	23
3.4.4.3	Angle Calculation .....	24
3.4.5	Angle Performance .....	25
3.5	Safety Features .....	26
3.5.1	Built in error diagnosis .....	26
3.5.2	External Diagnosis .....	26
3.5.2.1	Vector length check differential voltage mode .....	26
3.6	Electro Magnetic Compatibility (EMC) .....	27
<b>4</b>	<b>Package Information</b> .....	28
4.1	Package Parameters .....	28
4.2	Package Outline .....	28
4.3	Footprint .....	29
4.4	Packing .....	29
4.5	Marking .....	30
	<b>References</b> .....	31

## List of Figures

Figure 1	Sensitive bridges of the GMR sensor . . . . .	8
Figure 2	Ideal output of the GMR sensor bridges . . . . .	9
Figure 3	Pin configuration (top view) . . . . .	10
Figure 4	TLE5009 block diagram . . . . .	11
Figure 5	Application circuit for the TLE5009 . . . . .	12
Figure 6	Magnetic input field strength . . . . .	13
Figure 7	Single-ended output signals . . . . .	17
Figure 8	Differential output of ideal cosine . . . . .	18
Figure 9	Calibration routine . . . . .	19
Figure 10	Min-Max method . . . . .	20
Figure 11	Orthogonality error . . . . .	21
Figure 12	Correction of orthogonality error . . . . .	22
Figure 13	Implementation of angle calculation . . . . .	24
Figure 14	Valid vector length . . . . .	26
Figure 15	Package dimensions . . . . .	28
Figure 16	Position of sensing element . . . . .	29
Figure 17	Footprint . . . . .	29
Figure 18	Tape and reel . . . . .	29

## List of Tables

Table 1	Pin description . . . . .	10
Table 2	Absolute maximum ratings . . . . .	12
Table 3	Operating range . . . . .	13
Table 4	Electrical parameters . . . . .	15
Table 5	ESD protection . . . . .	15
Table 6	Single-ended output parameters . . . . .	17
Table 7	Differential output parameters . . . . .	18
Table 8	Angle performance in differential applications . . . . .	25
Table 9	Valid vector length . . . . .	27
Table 10	Package parameters. . . . .	28

# 1 Product Description



## 1.1 Overview

The TLE5009 is an angle sensor with analog outputs. It detects the orientation of a magnetic field by measuring sine and cosine angle components with **Giant Magneto Resistance (GMR)** elements. It provides analog sine and cosine output voltages that describe the magnet angle in a range of 0 to 360°.

The differential GMR bridge signals are temperature compensated and independent of the magnetic field strength to maintain constant output voltage over a wide temperature and field range. The analog output is designed for differential applications.

The output voltages are designed to use the dynamic range of an A/D-converter using the same supply as the sensor as voltage reference. Product type TLE5009-E2000 and TLE5009-E2010 are intended for use in circuits with 5 Volts supply. Product types TLE5009-E1000 and TLE5009-E1010 are intended for use in 3.3V applications. Product types TLE5009-E2010 and TLE5009-E1010 have improved angular accuracy achieved by production trimming at two temperatures.

## 1.2 Features

- 3V to 5.5V operating supply voltage
- Low current consumption and very quick start up
- Overvoltage detection
- 360° contactless angle measurement
- Output amplitude optimized for circuits with 3.3V or 5V supply voltage (type -E10x0 or -E20x0 respectively)
- Immune to airgap variations due to GMR based sensing principle
- Output amplitude constant over a wide temperature range: -40°C to 150°C (junction temperature)
- High accuracy typically 0.6° overall angle error
- AEC-Q100 automotive qualified
- Green package with lead-free (Pb-free) plating

## 1.3 Target Applications

The TLE5009 GMR angle sensor is designed for angular position sensing in automotive applications. Its high accuracy combined with short propagation delay makes it suitable for systems with high speeds and high accuracy demands such as rotor position measurement for electric motor commutation. At the same time its fast start-up time and low overall power consumption enables the device to be employed in low-power applications. Extremely low power consumption can be achieved with power cycling, where the device excels with fastest power on time.

- Rotor position sensing for electric motor commutation
- Rotary switches
- Steering angle sensing
- Valve or flap position sensing

Product Type	Marking	Ordering Code	Package
TLE5009-E2000	0092000	SP000912760	PG-DSO-8
TLE5009-E1000	0091000	SP000912764	PG-DSO-8
TLE5009-E2010	0092010	SP000912770	PG-DSO-8
TLE5009-E1010	0091010	SP000912774	PG-DSO-8

## 2 Functional Description

### 2.1 General

The GMR sensor is implemented using vertical integration. This means that the GMR sensitive areas are integrated above the analog portion of the TLE5009 chip. These GMR elements change their resistance depending on the direction of the magnetic field.

Four individual GMR elements are connected in a Wheatstone bridge arrangement. Each GMR element senses one of two components of the applied magnetic field:

- X component,  $V_x$  (cosine) or the
- Y component,  $V_y$  (sine)

The advantage of a full-bridge structure is that the amplitude of the GMR signal is doubled and temperature effects cancel out.

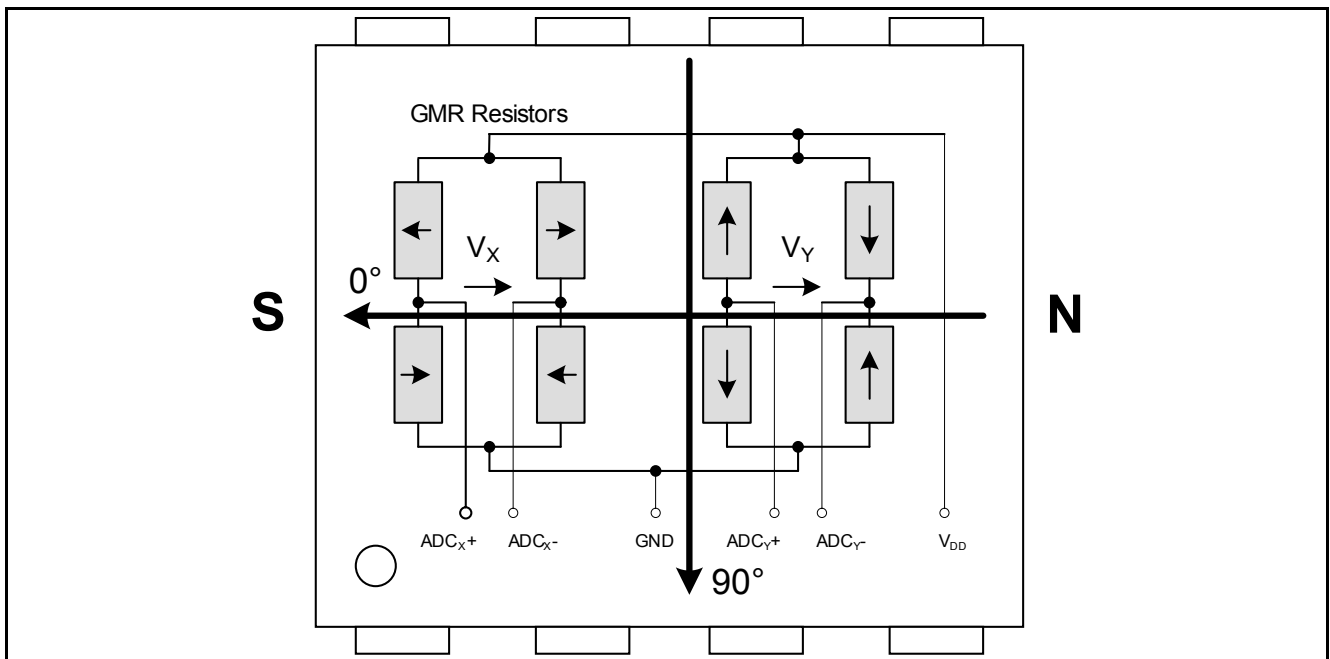

**Figure 1 Sensitive bridges of the GMR sensor**

*Note: In [Figure 1](#), the arrows in the resistors symbolize the direction of the reference layer. Size of the sensitive areas is greatly exaggerated for better visualisation.*

The output signal of each bridge is unambiguous in a range of 180°. Therefore two bridges are oriented orthogonally to each other to measure 360°.

With the trigonometric function ARCTAN, the true 360° angle value that is represented by the relation of X and Y signals can be calculated according to [Equation \(1\)](#).

$$\alpha = \arctan \left( \frac{V_Y}{V_X} \right) \quad (1)$$

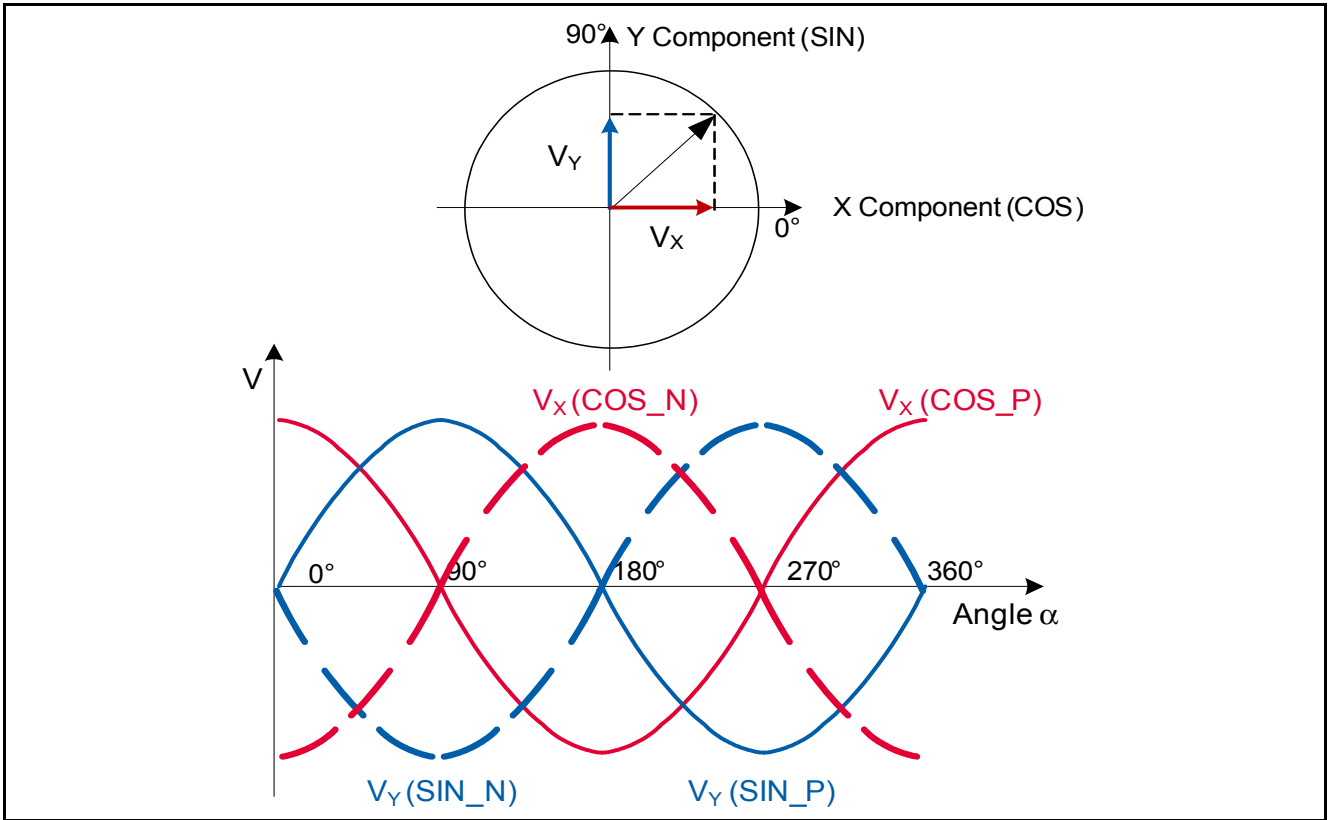

Figure 2 Ideal output of the GMR sensor bridges

## 2.2 Pin Configuration

The sensitive area is located at the center of the chip.

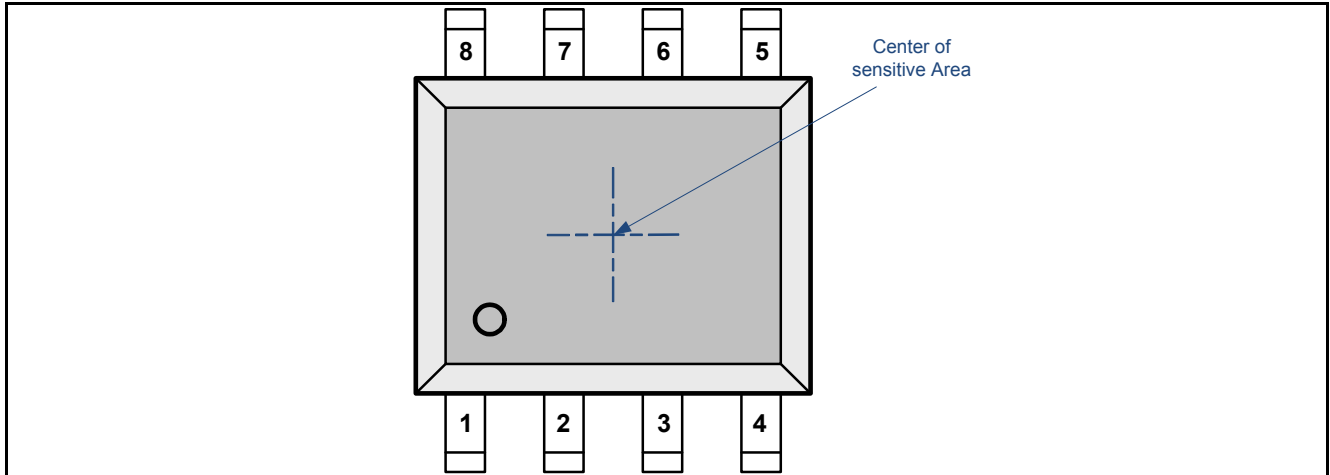

Figure 3 Pin configuration (top view)

## 2.3 Pin Description

Table 1 Pin description

Pin No.	Symbol	In/Out	Function
1	COS_P	O	Analog positive cosine output
2	COS_N	O	Analog negative cosine output
3	GND2		Ground
4	GND1		Ground
5	$V_{GMR}$	O	GMR bridge voltage proportional to temperature. Diagnostic function.
6	$V_{DD}$		Supply voltage
7	SIN_N	O	Analog negative sine output
8	SIN_P	O	Analog positive sine output

## 2.4 Block Diagram

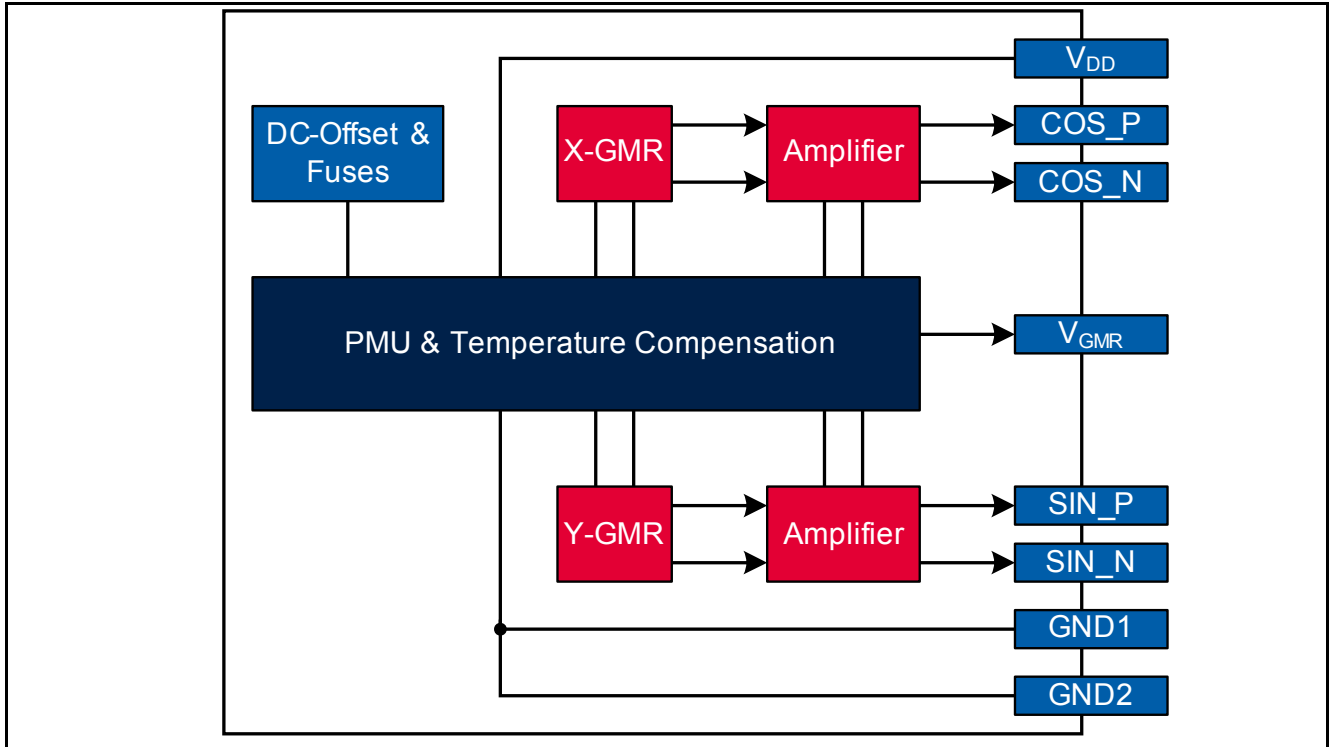

Figure 4 TLE5009 block diagram

### 3 Specification

#### 3.1 Application Circuit

Figure 5 shows a typical 5V application circuit. The sensor is supplied by the same supply as the microcontroller. The microcontroller comprises 5 A/D inputs used to read in the sensor output signals. For reasons of EMC and output filtering, the following RC low pass arrangement is recommended.

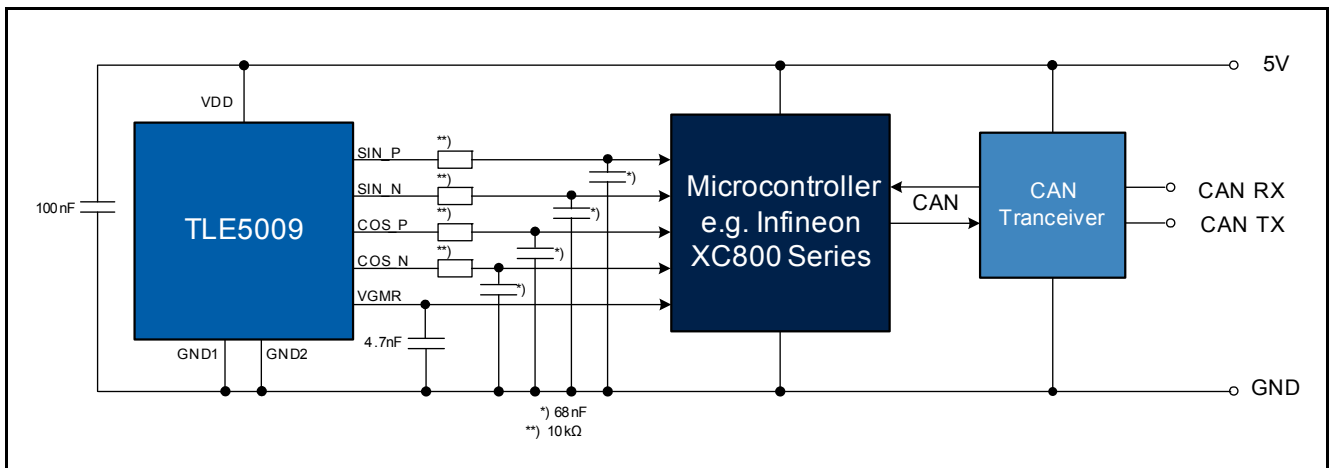

Figure 5 Application circuit for the TLE5009

#### 3.2 Absolute Maximum Ratings

Table 2 Absolute maximum ratings

Parameter	Symbol	Values			Unit	Note / Test Condition
		Min.	Typ.	Max.		
Supply voltage	$V_{DD}$	-0.5		6.5	V	Max 40 h / lifetime
Junction temperature	$T_J$	-40		150	°C	
				150		For 1000 h not additive
Magnetic field induction	B			200	mT	Max. 5 min @ $T_A = 25^\circ\text{C}$
				150		Max. 5 h @ $T_A = 25^\circ\text{C}$
Storage temperature	$T_{ST}$	-40		150	°C	Without magnetic field

**Attention:** Stresses above the max. values listed here may cause permanent damage to the device. Exposure to absolute maximum rating conditions for extended periods may affect device reliability. Maximum ratings are absolute ratings; exceeding only one of these values may cause irreversible damage to the device.

### 3.3 Operating Range

The following operating conditions must not be exceeded in order to ensure correct operation of the TLE5009. All parameters specified in the following sections refer to these operating conditions, unless otherwise noticed. **Table 3** is valid for  $-40^{\circ}\text{C} < T_j < 150^{\circ}\text{C}$ .

**Table 3 Operating range**

Parameter	Symbol	Values			Unit	Note / Test Condition
		Min.	Typ.	Max.		
Supply voltage <sup>1)</sup>	$V_{DD}$	4.5	5.0	5.5	V	TLE5009-E2000, TLE5009-E2010
		3.0	3.3	3.6	V	TLE5009-E1000, TLE5009-E1010
Output current <sup>2)</sup>	$I_Q$	0		0.5	mA	COS_N; COS_P; SIN_N; SIN_P
		0		0.1	mA	$V_{GMR}$
Load capacitance <sup>2)3)</sup>	$C_L$	0		4.7	nF	COS_N; COS_P; SIN_N; SIN_P; $V_{GMR}$
Magnetic field <sup>2)4)</sup>	$B_{XY\_25}$	24		50	mT	at room temperature, in X/Y direction
Angle range	$\alpha$	0		360	°	
Rotation speed <sup>2)5)</sup>	n			30000	rpm	

- 1) Supply voltage  $V_{DD}$  buffered with 100 nF ceramic capacitor in close proximity to the sensor.
- 2) Not subject to production test - verified by design/characterization.
- 3) Directly connected to the pin.
- 4) Values refer to an homogenous magnetic field ( $B_{XY}$ ) without vertical magnetic induction ( $B_z = 0\text{mT}$ ).
- 5) Typical angle propagation delay is  $1.62^{\circ}$  at 30000 rpm.

The magnetic field is defined at room temperature. Depending on the maximum junction temperature the maximum field strength is shown in **Figure 6**. In case of a maximum junction temperature  $T_j = 100^{\circ}\text{C}$  a magnet with up to 60mT at room temperature is applicable. The window for magnetic field in **Table 3** is valid for the max junction temperature of the device.

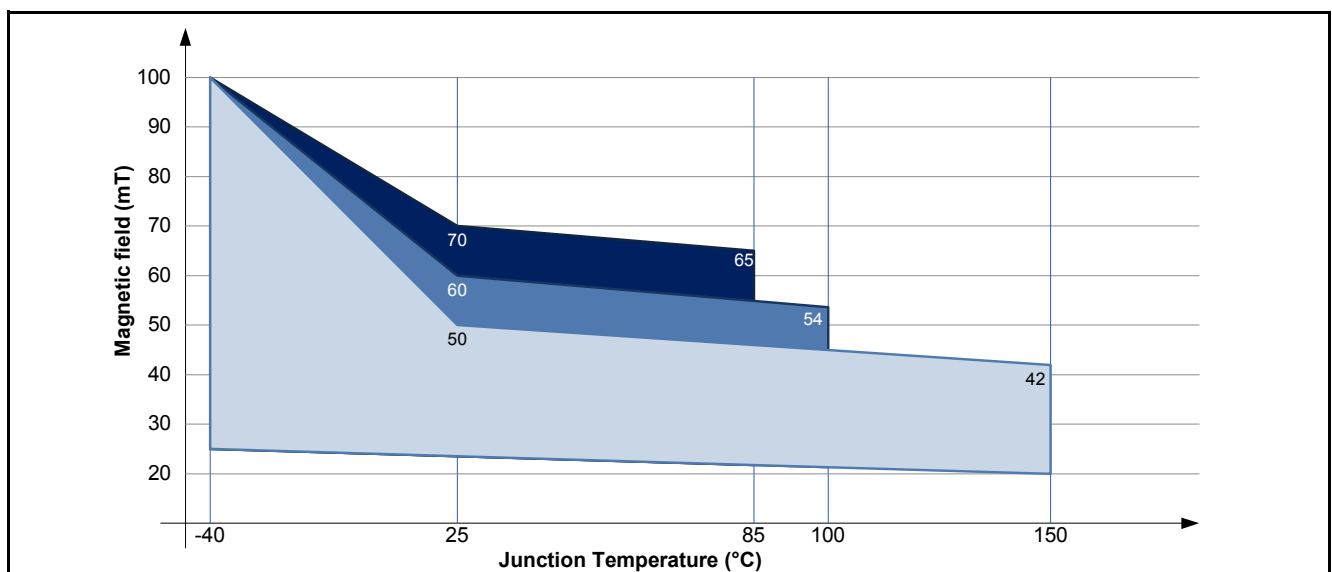

**Figure 6 Magnetic input field strength**

Note: The thermal resistances listed in **Table 10 "Package parameters" on Page 28** must be used to calculate the corresponding ambient temperature.

**Calculation of the Junction Temperature**

The total power dissipation  $P_{TOT}$  of the chip increases its temperature above the ambient temperature.

The power multiplied by the total thermal resistance  $R_{thJA}$  (Junction-to-Ambient) leads to a calculation of the final junction temperature.  $R_{thJA}$  is the sum of the addition of the values of the two components Junction-to-Case and Case-to-Ambient.

$$R_{thJA} = R_{thJC} + R_{thCA}$$

$$T_J = T_A + \Delta T \tag{2}$$

$$\Delta T = R_{thJA} \times P_{TOT} = R_{thJA} \times (V_{DD} \times I_{DD} + (V_{DD} - V_{OUT}) \times I_{OUT})$$

Example (assuming no load on  $V_{out}$ ):

$$V_{DD} = 5V$$

$$I_{DD} = 7mA$$

$$\Delta T = 150 \left[ \frac{K}{W} \right] \times (5[V] \times 0.007[A] + 0[V] \times 0[A]) = 5.25K \tag{3}$$

For molded sensors, the calculation with  $R_{thJC}$  is more appropriate.

### 3.4 Characteristics

#### 3.4.1 Electrical Parameters

The indicated electrical parameters apply to the full operating range, unless otherwise specified. The typical values correspond to a supply voltage  $V_{DD} = 3.0V - 5.5 V$  and  $25\text{ }^{\circ}C$ , unless individually specified. All other values correspond to  $-40^{\circ}C < T_J < 150^{\circ}C$ .

**Table 4 Electrical parameters**

Parameter	Symbol	Values			Unit	Note / Test Condition
		Min.	Typ.	Max.		
Supply current	$I_{DD}$		7	10.5	mA	Without resistive or capacitive load on output pins
POR level	$V_{POR}$	2.4	2.65	2.97	V	Power-On Reset
POR hysteresis <sup>1)</sup>	$V_{PORhy}$		50		mV	
Power-On time	$t_{PON}$		30	40	$\mu s$	Measured on $V_{GMR}$ pin without external circuit
Temperature reference voltage	$V_{GMR}$	0.6	1.052	1.8	V	<b>Temperature proportional</b> output voltage; available on pin $V_{GMR}$
Diagnostic function	$V_{GMR}$	0		0.39	V	<b>Diagnostic</b> for internal errors; available on pin $V_{GMR}$
Temperature coefficient of $V_{GMR}$ <sup>1)</sup>	$TC_{VGMR}$		0.4		%/K	

1) Not subject to production test - verified by design/characterization

#### 3.4.2 Electrostatic discharge protection

**Table 5 ESD protection**

Parameter	Symbol	Values		Unit	Notes
		min.	max.		
ESD voltage	$V_{HBM}$		$\pm 4.0$	kV	Human Body Model <sup>1)</sup>
	$V_{SDM}$		$\pm 0.5$	kV	Socketed Device Model <sup>2)</sup>

1) Human Body Model (HBM) according to: ANSI/ESDA/JEDEC JS-001

2) Socketed Device Model (SDM) according to: ESDA/ANSI/ESD SP5.3.2-2008

### 3.4.3 Output Parameters

All parameters apply over the full operating range, unless otherwise specified. The parameters in [Table 6](#) refer to single-ended output and [Table 7](#) to differential output. For variable names please refer to [Figure 7 “Single-ended output signals” on Page 17](#) and [Figure 8 “Differential output of ideal cosine” on Page 18](#).

The following equations describe various types of errors that combine to the overall angle error.

The maximum and zero-crossing of the SIN and COS signals do not occur at the precise angle of 90°. The difference between the X and Y phases is called the **orthogonality** error. In [Equation \(4\)](#) the angle at zero crossing of the **X** cosine output is subtracted from the angle at the maximum of the **Y** SIN output, which describes the orthogonality of X and Y.

$$\varphi = \alpha[Y_{\max}] - \alpha[X_0] \tag{4}$$

The amplitudes of SIN and COS signals are not equal to each other. The amplitude mismatch is defined as **synchronism**, shown in [Equation \(5\)](#). This value could also be described as amplitude ratio mismatch.

$$k = 100 * \frac{A_X}{A_Y} \tag{5}$$

**Differential** signals are centered at the mean output voltage  $V_{MVX}$ ,  $V_{MYY}$  given in [Table 6](#). The differential voltages for X or Y are defined in [Equation \(6\)](#).

$$\begin{aligned} V_{Xdiff} &= V_{COSP} - V_{COSN} \\ V_{Ydiff} &= V_{SINP} - V_{SINN} \end{aligned} \tag{6}$$

The maximum amplitudes are defined for X or Y as given in [Equation \(7\)](#):

$$\begin{aligned} A_{Xdiff} &= \frac{(X_{diff\_MAX} - X_{diff\_MIN})}{2} \\ A_{Ydiff} &= \frac{(Y_{diff\_MAX} - Y_{diff\_MIN})}{2} \end{aligned} \tag{7}$$

Differential offset of X or Y is defined in [Equation \(8\)](#).

$$\begin{aligned} O_{Xdiff} &= \frac{(X_{diff\_MAX} + X_{diff\_MIN})}{2} \\ O_{Ydiff} &= \frac{(Y_{diff\_MAX} + Y_{diff\_MIN})}{2} \end{aligned} \tag{8}$$

In single-ended mode the offset is defined as the mean output voltage.

**Table 6 Single-ended output parameters**

Parameter	Symbol	Values			Unit	Note / Test Condition
		Min.	Typ.	Max.		
X, Y amplitude <sup>1)</sup>	$A_X, A_Y$	1.40		1.85	V	TLE5009-E2000, TLE5009-E2010
		0.90		1.20	V	TLE5009-E1000, TLE5009-E1010
X, Y synchronism <sup>2)</sup>	k	95	100	105	%	
X, Y orthogonality error <sup>2)</sup>		-10	0	10	°	
Mean output voltage <sup>3)</sup>	$V_{MVX}, V_{MVY}$	$0.48 \cdot V_{DD}$	$0.5 \cdot V_{DD}$	$0.52 \cdot V_{DD}$	V	$V_{MV} = (V_{max} - V_{min}) / 2$
X, Y cut off frequency <sup>4)</sup>	$f_c$		30		kHz	-3dB attenuation
X, Y delay time <sup>4)</sup>	$t_{adel}$		9		µs	
Output noise <sup>4)</sup>	$V_{Noise}$		1.5		mV	RMS

- 1) Valid at 0h
- 2) Valid at 25°C, 0h
- 3) Including X, Y offset
- 4) Not subject to production test - verified by design/characterization

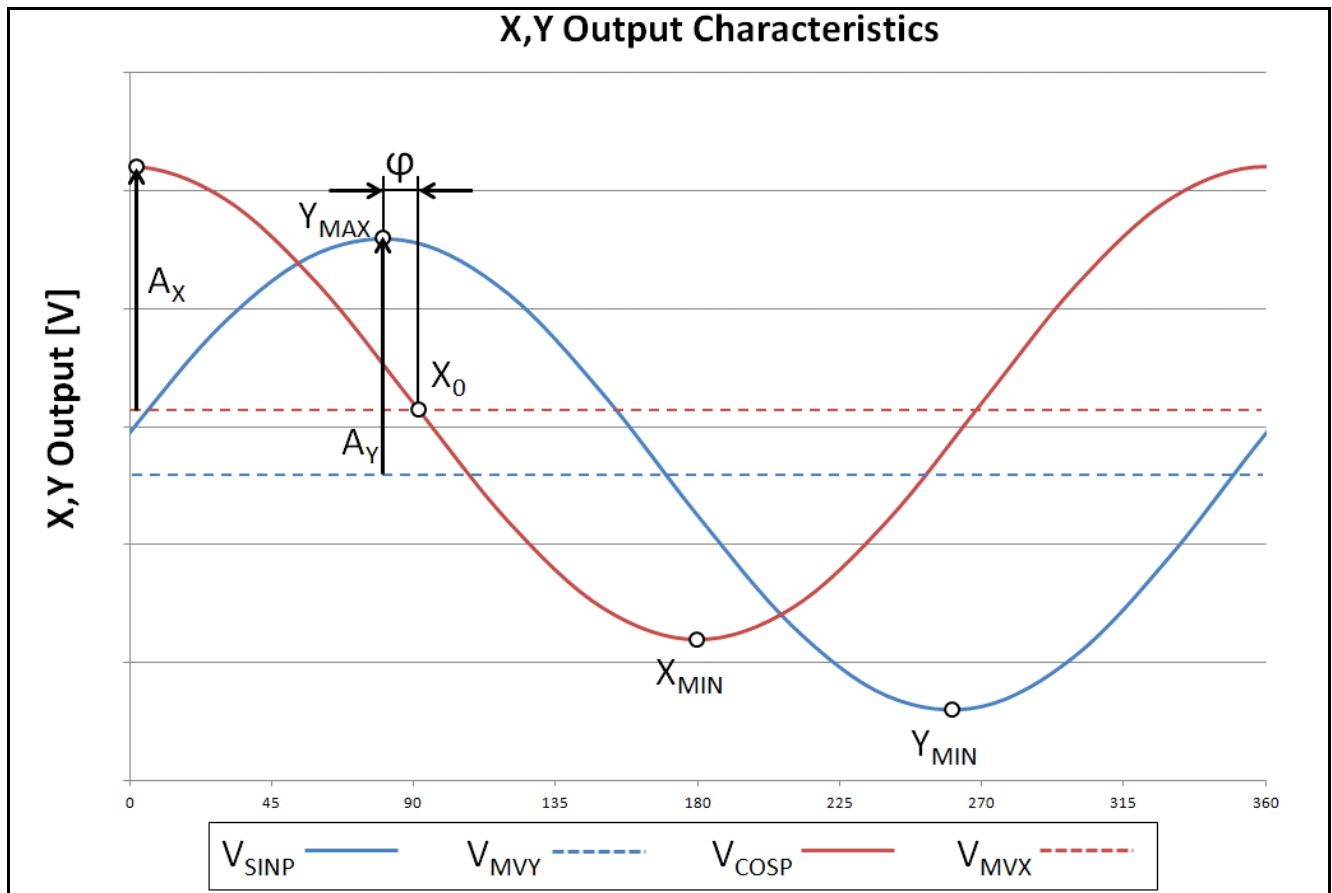
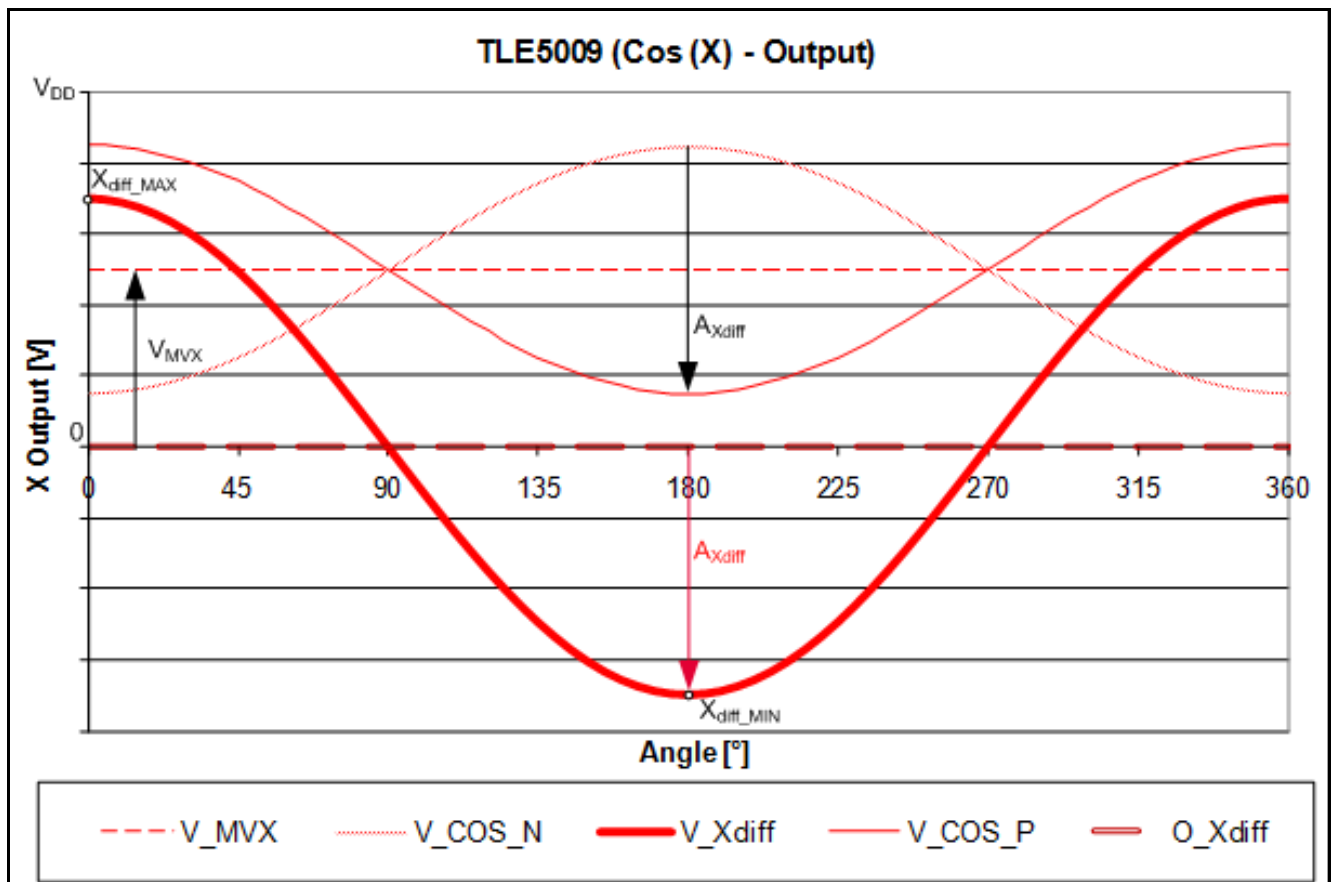

**Figure 7 Single-ended output signals**

**Table 7 Differential output parameters**

Parameter	Symbol	Values			Unit	Note / Test Condition
		Min.	Typ.	Max.		
X, Y amplitude <sup>1)</sup>	$A_{Xdiff}, A_{Ydiff}$	2.8		3.7	V	TLE5009-E2000, TLE5009-E2010
		1.8		2.4	V	TLE5009-E1000, TLE5009-E1010
X, Y synchronism <sup>2)</sup>	k	95	100	105	%	
X, Y offset <sup>2)</sup>	$O_{Xdiff}, O_{Ydiff}$	-50	0	50	mV	
X, Y orthogonality error <sup>2)</sup>	$\varphi$	-10	0	10	°	
X,Y cut-off frequency <sup>3)</sup>	$f_c$		30		kHz	-3dB attenuation
X,Y delay time <sup>3)</sup>	$t_{adel}$		9		$\mu s$	
Output noise <sup>3)</sup>	$V_{Noise}$		3		mV	RMS

- 1) Valid at 0h
- 2) Valid at 25°C, 0h
- 3) Not subject to production test - verified by design/characterization

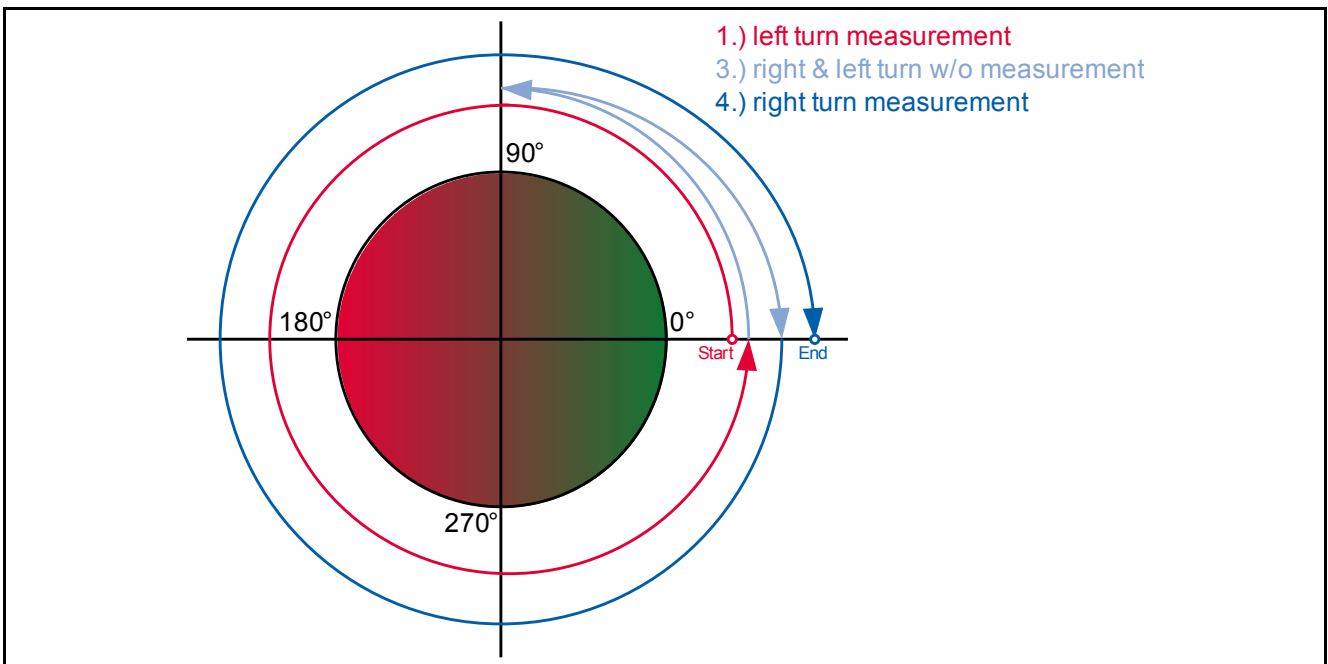

**Figure 8 Differential output of ideal cosine**

### 3.4.4 Calibration of TLE5009

This chapter explains how to determine the Giant MagnetoResistance (GMR) parameters such as amplitude, offset, and the phase of X- and Y-channels. Extraction of these parameters is essential to achieve the angle accuracy given in [Table 8 “Angle performance in differential applications” on Page 25](#).

The end-of-line calibration is accomplished using the following sequence ([Figure 9](#)):



**Figure 9 Calibration routine**

1. Turn magnetic field 360° **left** and measure X and Y values
2. Calculate amplitude, offset, phase correction values of left turn
3. Turn further 90° left and 90° back right without measurement
4. Turn magnetic field 360° **right** and measure X and Y values
5. Calculate amplitude, offset, phase correction values of right turn
6. Calculate **mean** values of amplitude, offset, phase correction

The calibration has to be done at room temperature with a magnet in the specified magnetic field range.

#### 3.4.4.1 Extraction of Parameters

There are two possible methods for extracting these parameters. The methods will be discussed in more detail in the next two sections.

##### 3.4.4.1.1 Min-Max Method

$X_{max}$ ,  $X_{min}$ ,  $Y_{max}$  and  $Y_{min}$  have to be extracted out of every full-turn measurement ([Figure 10](#)).

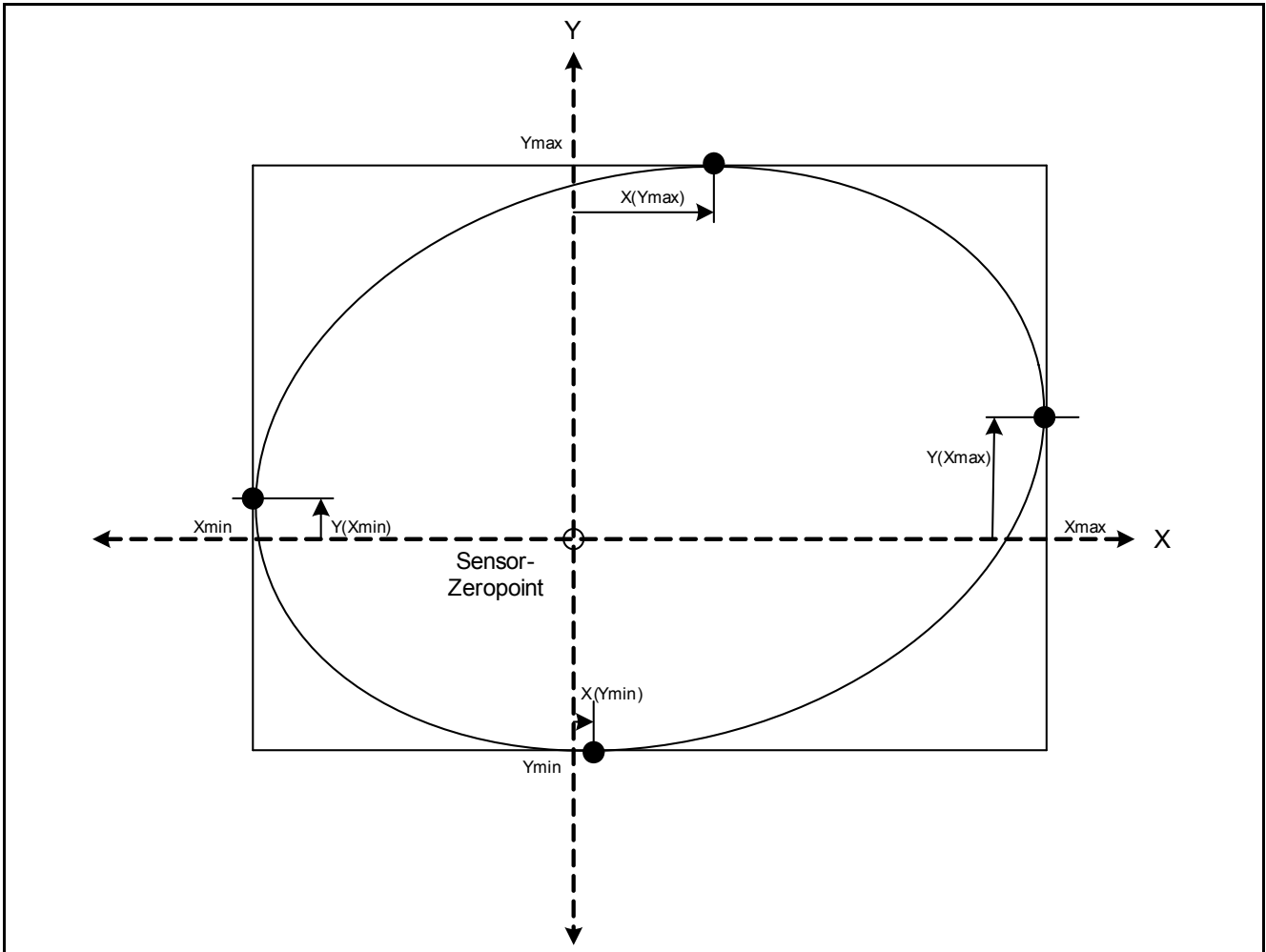

**Figure 10 Min-Max method**

Afterwards, amplitude ([Equation \(9\)](#), [Equation \(10\)](#)) and offset ([Equation \(11\)](#), [Equation \(12\)](#)) can be calculated:

$$A_X = \frac{X_{\max} - X_{\min}}{2} \tag{9}$$

$$A_Y = \frac{Y_{\max} - Y_{\min}}{2} \tag{10}$$

$$O_X = \frac{X_{\max} + X_{\min}}{2} \tag{11}$$

$$O_Y = \frac{Y_{\max} + Y_{\min}}{2} \tag{12}$$

The corresponding maximum and zero-crossing points of the SIN and COS signals do not occur at the precise distance of 90°. The difference between X and Y phases is called the orthogonality error ([Equation \(13\)](#)):

$$\varphi = \varphi_X - \varphi_Y \tag{13}$$

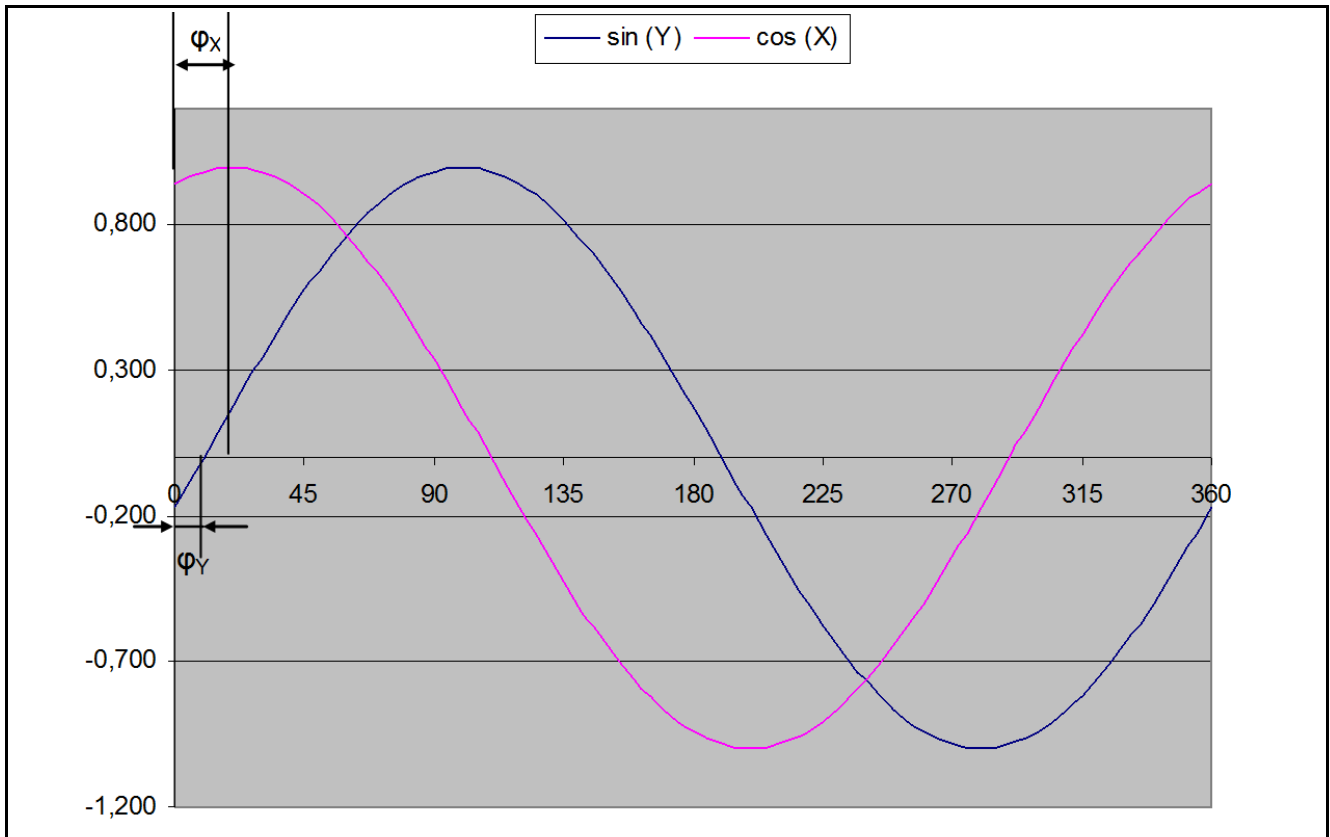

**Figure 11 Orthogonality error**

There is another more accurate way to determine the orthogonality error. The orthogonality can be calculated out of the magnitude of two 90° angle shifted components. Possible angle combinations are 45° and 135°, 135° and 225°, 225° and 315° or 315° and 45°.

The angle value is given by the angle sensor. No reference is necessary. Therefore the final parameters of amplitude and offset (**Chapter 3.4.4.2**) should be used.

At an angle output of 45° the corresponding Y(sin) and X(cos) values can be read out. This has been done also at 135° (**Figure 12**).

Next step is to calculate the length of the magnitudes (**Equation (14)**):

$$M_{45} = \sqrt{X_{45}^2 + Y_{45}^2} \tag{14}$$

$$M_{135} = \sqrt{X_{135}^2 + Y_{135}^2}$$

$M_{45}$ ,  $M_{135}$ .. Magnitude at 45° and 135°

$X_{45}$ ,  $X_{135}$  .. Cosine values at 45° and 135°

$Y_{45}$ ,  $Y_{135}$  .. Sine values at 45° and 135°

With these magnitudes the orthogonality can be calculated (**Equation (15)**):

$$\varphi = 2 * \arctan\left(\frac{M_{135} - M_{45}}{M_{135} + M_{45}}\right) \tag{15}$$

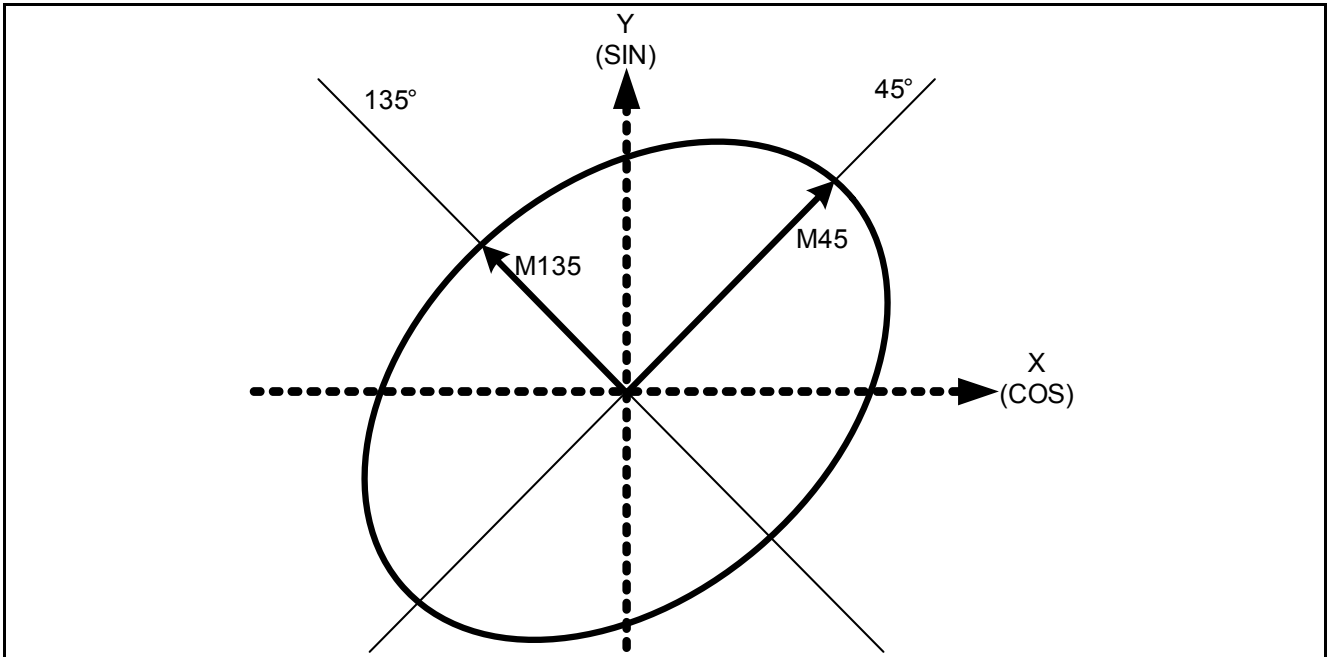

Figure 12 Correction of orthogonality error

### 3.4.4.1.2 Exact Method

This method uses the Discrete Fourier Transform (DFT) to extract the parameters out of the measurements. Therefore an accurate reference system is necessary. This method is done using  $2^m$  measurement points at  $360^\circ$  (e.g.  $m = 8$ ;  $n = 2^m = 2^8 = 64$ ).

#### DFT Offset Calculation:

The offset is calculated by the summation of the X- or Y- measurements divided by the number of measurement points (Equation (16)):

$$O_x = [X(1) + X(2) + \dots + X(n)] / n$$

$$O_y = [Y(1) + Y(2) + \dots + Y(n)] / n$$
(16)

X(n) .. X value at measurement point n

Y(n) .. Y value at measurement point n

n .. Measurement points

#### DFT Amplitude and Phase Calculation:

To determine the amplitude, the real and imaginary parts must be calculated. This has been done with Equation (17) for the X values and Equation (18) for the Y values.  $\beta$  describes the reference angle (e.g.  $n = 64$ ; measurement every  $360^\circ / 64 = 5.625^\circ$  step).

describes the reference angle (e.g.  $n = 64$ ; measurement every  $360^\circ / 64 = 5.625^\circ$  step).

$$\overline{DFT\_X\_r} = [X(1) * \cos(\beta_1) + X(2) * \cos(\beta_2) + \dots + X(n) * \cos(\beta_n)] * 2 / n$$

$$\overline{DFT\_X\_i} = [X(1) * \sin(\beta_1) + X(2) * \sin(\beta_2) + \dots + X(n) * \sin(\beta_n)] * 2 / n$$
(17)

$$\overline{DFT\_Y\_r} = [Y(1) * \cos(\beta_1) + Y(2) * \cos(\beta_2) + \dots + Y(n) * \cos(\beta_n)] * 2 / n$$

$$\overline{DFT\_Y\_i} = [Y(1) * \sin(\beta_1) + Y(2) * \sin(\beta_2) + \dots + Y(n) * \sin(\beta_n)] * 2 / n$$
(18)

Now the amplitude and phase can be calculated ([Equation \(19\)](#), [Equation \(20\)](#))

$$A_X = \sqrt{(DFT\_X\_r)^2 + (DFT\_X\_i)^2} \tag{19}$$

$$A_Y = \sqrt{(DFT\_Y\_r)^2 + (DFT\_Y\_i)^2} \tag{20}$$

$$\varphi_X = \arctan \frac{DFT\_X\_i}{DFT\_X\_r}$$

$$\varphi_Y = \frac{\pi}{2} - \arctan \frac{DFT\_Y\_i}{DFT\_Y\_r}$$

$$\varphi = \varphi_X - \varphi_Y$$

### 3.4.4.2 Final Parameters

No matter what calibration method is used, you still have to calculate the symmetrical values of the parameters. This is done using the mean value of the clock-wise (cw) rotation parameters and counterclock-wise (ccw) rotation parameters. This calculation has to be done with X and Y parameters. These parameters have to be used for the signal correction.

$$A_M = \frac{A_{cw} + A_{ccw}}{2}$$

$$O_M = \frac{O_{cw} + O_{ccw}}{2} \tag{21}$$

$$\varphi_M = \frac{\varphi_{cw} + \varphi_{ccw}}{2}$$

$(A,O,\varphi)_M$  .. Mean parameters

$(A,O,\varphi)_{CW}$  .. Parameters of clock-wise rotation

$(A,O,\varphi)_{CCW}$  .. Parameters of counterclock-wise rotation

### 3.4.4.3 Angle Calculation

To get highly accurate angle values, the following angle calculation must be performed. **Figure 13** shows the implementation within a microcontroller.

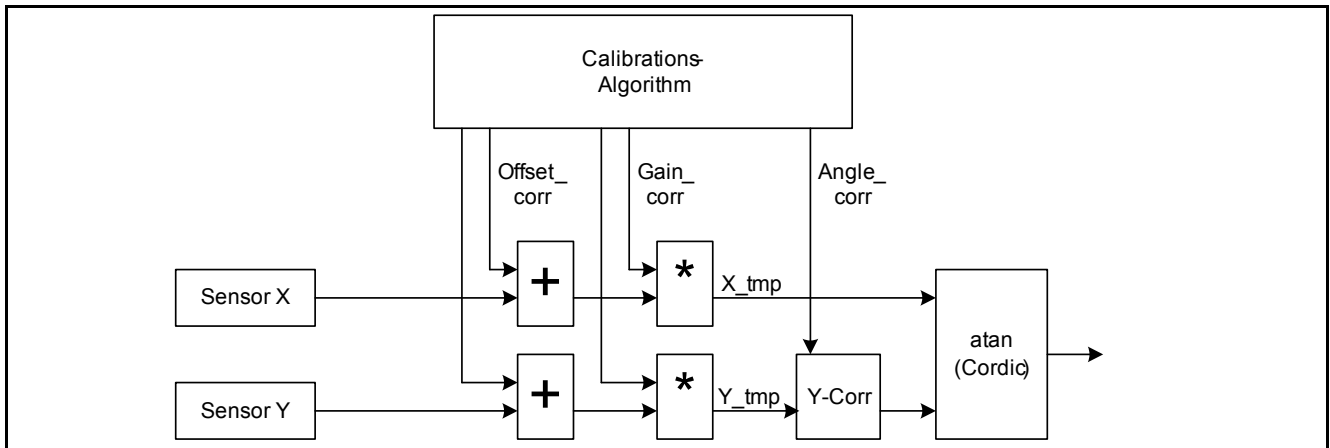

**Figure 13** Implementation of angle calculation

#### Offset Correction (Offset\_corr)

After the X and Y values are read out, the room temperature offset value must be subtracted (**Equation (22)**):

$$\begin{aligned} X_1 &= X - O_X \\ Y_1 &= Y - O_Y \end{aligned} \tag{22}$$

#### Amplitude Normalization (Gain\_corr)

The next step is to normalize the X and Y values by using the mean values determined in the calibration.

$$\begin{aligned} X_2 &= \frac{X_1}{A_{XM}} \\ Y_2 &= \frac{Y_1}{A_{YM}} \end{aligned} \tag{23}$$

#### Non-Orthogonality Correction (Angle\_corr)

The influence of the non-orthogonality can be compensated for by using **Equation (24)**, in which only the Y channel must be corrected.

$$Y_3 = \frac{Y_2 - X_2 * \sin(-\varphi)}{\cos(-\varphi)} \tag{24}$$

#### Resulting Angle

After correction of all errors, the resulting angle<sup>1)</sup> can be calculated using the arctan function<sup>1)</sup>.

$$\alpha = \arctan\left(\frac{Y_3}{X_2}\right) - \varphi_X \tag{25}$$

1) Microcontroller library function "arctan2(Y<sub>3</sub>,X<sub>2</sub>)" works better to resolve 360°

### 3.4.5 Angle Performance

The overall angle error represents the relative angular error. This error describes the deviation from the reference line after zero angle definition. The typical value correspond to a supply voltage  $V_{DD} = 3.0V - 5.5 V$  and  $25\text{ }^{\circ}C$ , unless individually specified. All other values correspond to  $-40^{\circ}C < T_J < 150^{\circ}C$ .

Calibration of offset, orthogonality, synchronism and phase error at  $25^{\circ}C$  are required to achieve the overall angle error specified. For the detailed calibration procedure refer to [Chapter 3.4.4](#).

Infineon offers temperature compensated versions of the device TLE5009-E2010, TLE5009-E1010. These devices have an improved angular accuracy as can be seen in [Table 8](#).

**Table 8 Angle performance in differential applications**

Parameter	Symbol	Values			Unit	Note / Test Condition
		Min.	Typ.	Max.		
Overall angle error <sup>1)2)3)</sup>	$\alpha_{ERR}$		0.6	3	$^{\circ}$	TLE5009-E2000, TLE5009-E1000
			0.6	2.2	$^{\circ}$	TLE5009-E2010, TLE5009-E1010

1) Including hysteresis error

2) Valid at 0h

3) Valid for differential applications. The mean output voltage variation in single ended mode is not included in the angle error. Please contact Infineon for information about possible optimization for single ended applications.

### 3.5 Safety Features

#### 3.5.1 Built in error diagnosis

The device sensor provides two functions at the  $V_{GMR}$  pin. During normal operation the voltage measured at this pin is temperature dependent. The typical voltage at room temperature and the temperature coefficient are given in [Table 4 “Electrical parameters” on Page 15](#).

The second purpose of pin  $V_{GMR}$  is the diagnosis functionality. In case the device detects an internal error, the pin is driven to a low level as described in [Table 4 “Electrical parameters” on Page 15](#).

The errors that can be detected by monitoring the status of the  $V_{GMR}$  pin are:

- Start-up failure
- Overvoltage at VDD (threshold level min. 6V, max. 7V)
- Undervoltage at internal nodes

#### 3.5.2 External Diagnosis

Addressing the demands for functional safety, run time checks can be done to increase the diagnostic coverage. Depending on the application specifics such as the available time and processing capabilities, the sensor behaviour is monitored and compared with the specified behaviour of the device.

##### 3.5.2.1 Vector length check differential voltage mode

A comprehensive safety check is to monitor the vector length of  $V_x$  and  $V_y$  signals. Output signals representing sine and cosine have a fixed  $90^\circ$  phase relationship to each other. To determine if the output signals are valid, the length of the output vector length must be nearly constant independent of the magnet position.

The vector length corresponds to the amplitude of the output signals and utilizes the fact that there is a  $90^\circ$  phase shift between sine and cosine output. It is calculated according to [Equation \(26\)](#).

As illustrated in [Figure 14 “Valid vector length”](#), the vector describes a circle along one revolution of the magnet. The length of the vector is almost constant, slightly influenced by GMR synchronicity, orthogonality, offset and temperature.

$$V_{VEC} = \sqrt{V_{X\_DIFF}^2 + V_{Y\_DIFF}^2} \tag{26}$$

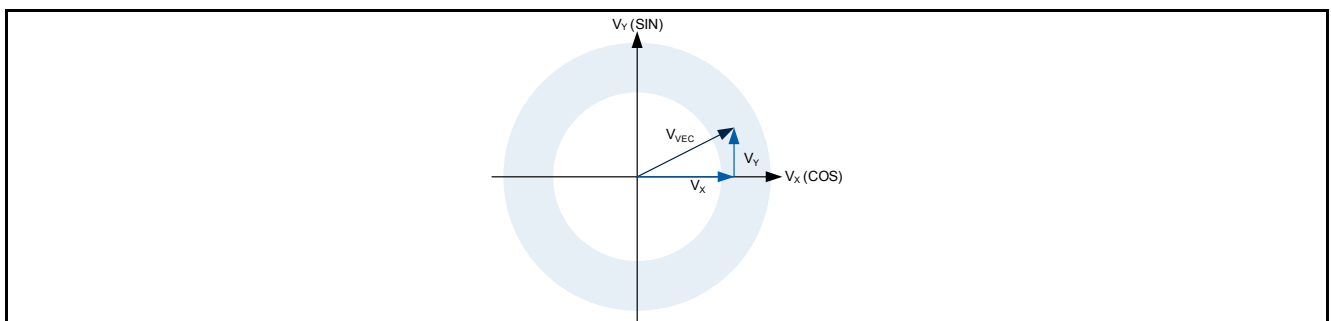

Figure 14 Valid vector length

**Table 9 Valid vector length**

Parameter	Symbol	Values			Unit	Note / Test Condition
		Min.	Typ.	Max.		
Vector length differential voltage	$V_{VEC}$	2.6		3.8	V	TLE5009-E2000, TLE5009-E2010
		1.6		2.7	V	TLE5009-E1000, TLE5009-E1010

The resulting vector length must always be within the range given in [Table 9](#), depending on the supply voltage type of the TLE5009 used. If the vector length is outside this range, then this might indicate malfunction of the TLE5009 or of the reading A/D converter.

### 3.6 Electro Magnetic Compatibility (EMC)

The TLE5009 is characterized according to the EMC requirements described in the “Generic IC EMC Test Specification” Version 1.2 from November 15, 2007. The classification of the TLE5009 is done for local pins.

## 4 Package Information

The TLE5009 comes in a green SMD package with lead-free plating, the **PG-DSO-8**. For alternative packaging, such as bare die please contact Infineon.

### 4.1 Package Parameters

Table 10 Package parameters

Parameter	Symbol	Limit Values			Unit	Notes
		min.	typ.	max.		
Thermal Resistance	$R_{thJA}$		150	200	K/W	Junction-to-Air <sup>1)</sup>
	$R_{thJC}$			75	K/W	Junction-to-Case
	$R_{thJL}$			85	K/W	Junction-to-Lead
Soldering Moisture Level		MSL 3				260°C
Lead Frame		Cu				
Plating		Sn 100%				> 7 $\mu$ m

1) According to Jecdec JESD51-7

### 4.2 Package Outline

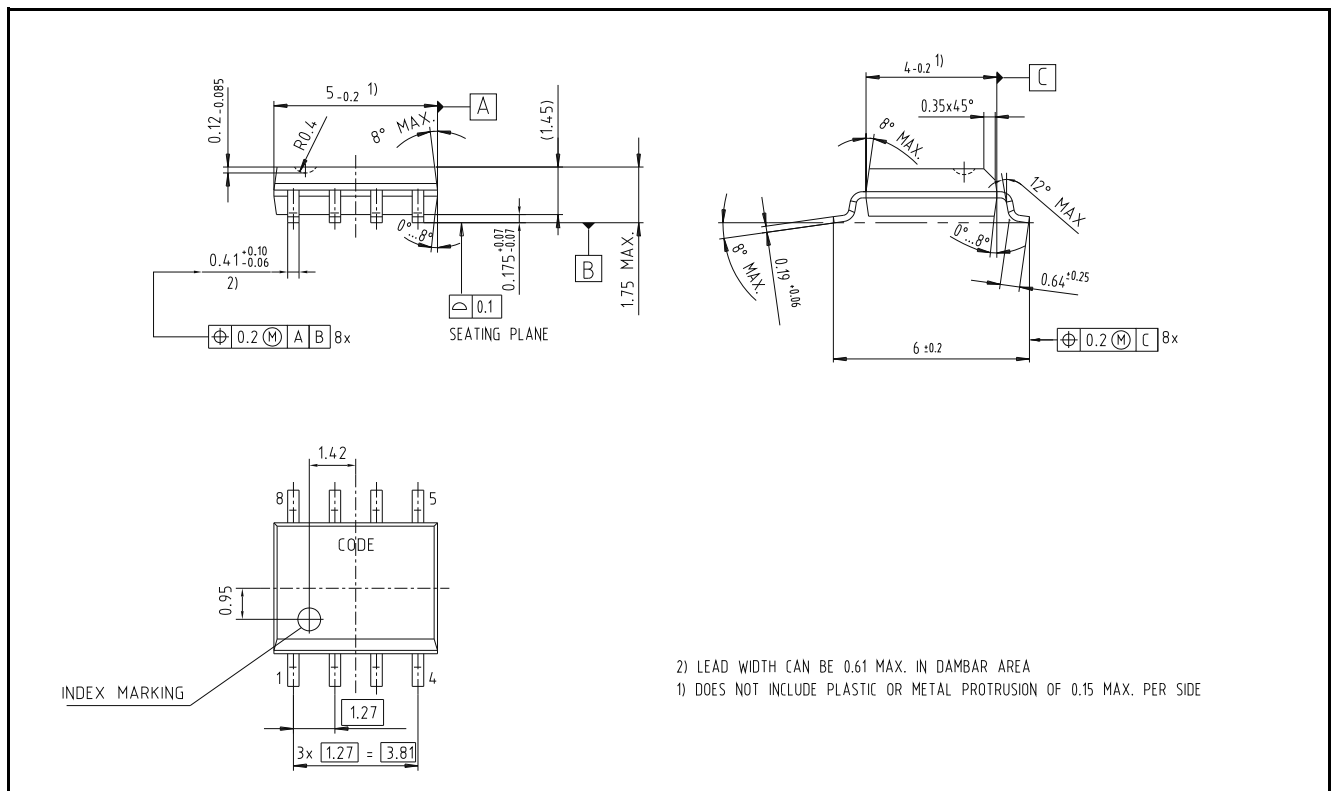

Figure 15 Package dimensions

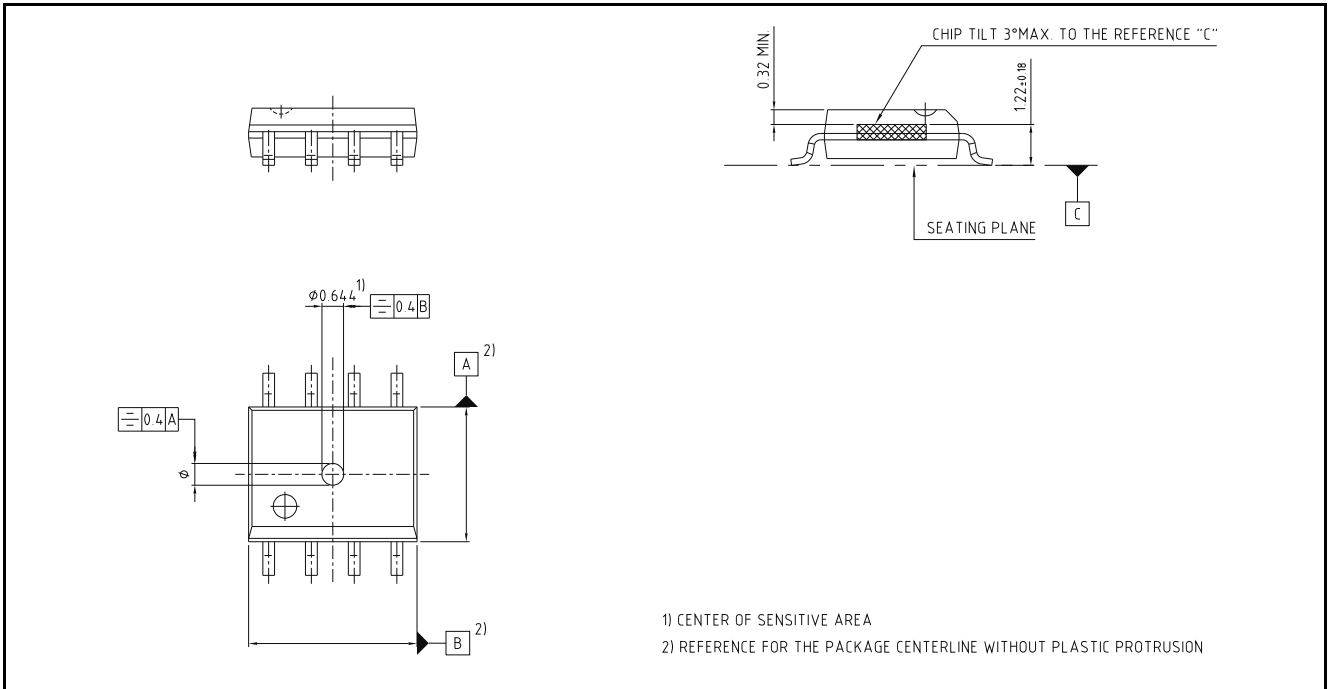

Figure 16 Position of sensing element

### 4.3 Footprint

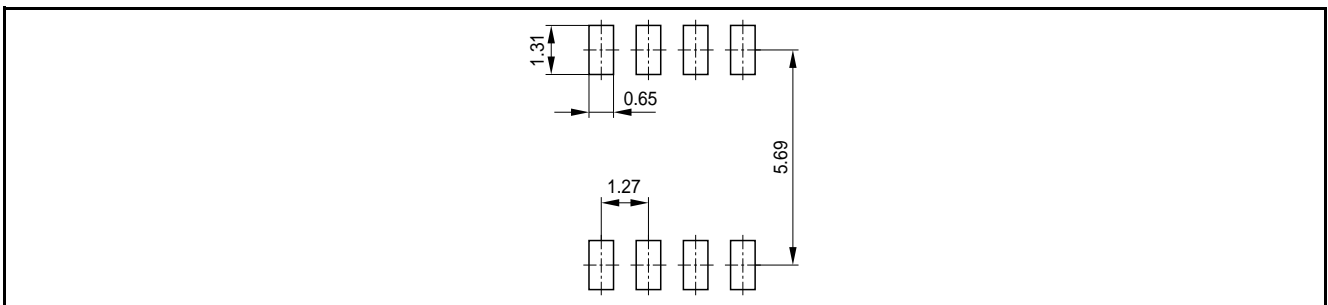

Figure 17 Footprint

### 4.4 Packing

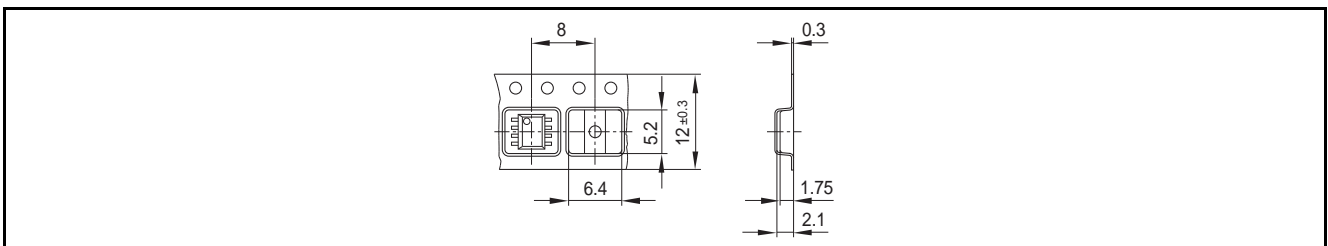

Figure 18 Tape and reel

## 4.5 Marking

Position	Marking	Description
1st Line	5009xxx	See ordering table on <a href="#">Page 7</a>
2nd Line	xxx	Lot code
3rd Line	GSxxxx	G..green, 4-digit..date code

## References

[www.infineon.com](http://www.infineon.com)

Published by Infineon Technologies AG

## Looking for pricing, stock, or lifecycle information?

Click below to explore more details on WIN SOURCE:

- ⊖ [View TLE5009E1010FUMA1 on WIN SOURCE](#)
- ⊖ [Infineon Technologies Information](#)

## Optimize Your Supply Chain with WIN SOURCE Solutions

- ✓ Global Sourcing Solution
- ✓ Obsolete Management
- ✓ Cost Control Management
- ✓ Shortage Management
- ✓ Alternative Solution
- ✓ Excess Inventory Management