



**THE DATASHEET OF  
ERA-3EEB1871V**



Digi-Key

Issue No. : 151ERA011011  
Date of Issue : February 15.2011  
Classification :  New  Changed

# PRODUCT SPECIFICATION FOR APPROVAL

Product Description : Metal Film (Thin Film)Chip Resistors (RoHS Compliance)  
Product Part Number : ERA3Y##\*\*\*V  
ERA3E##\*\*\*V  
Country of Origin : JAPAN  
Applications : Standard electronic equipment

\*If you approve this specification, please fill in and sign the below and return 1 copy to us.

Approval No	:	
Approval Date	:	
Executed by	:	
		_____
		(signature)
Title	:	
Dept.	:	

Circuit Components Business Unit  
Panasonic Electronic Devices Co., Ltd.

401 Sadamasa-cho,  
Fukui City 910-8502 Japan

Phone : +81-776-56-8034

Prepared by : Engineering Section  
Contact Person :  
Signature : H. Yabukoshi  
Name(Print) : H.Yabukoshi  
Title :

Authorized by :  
Signature : T. Iseki  
Name(Print) : T.Iseki  
Title : Manager of Engineering

**Panasonic**

Subject  
Metal Film(Thin Film) Chip Resistors PRODUCT SPECIFICATION FOR INFORMATION

Spec. No.

Part No.

**ERA3**

151-SRA-E102R

10-1

1. Dimension

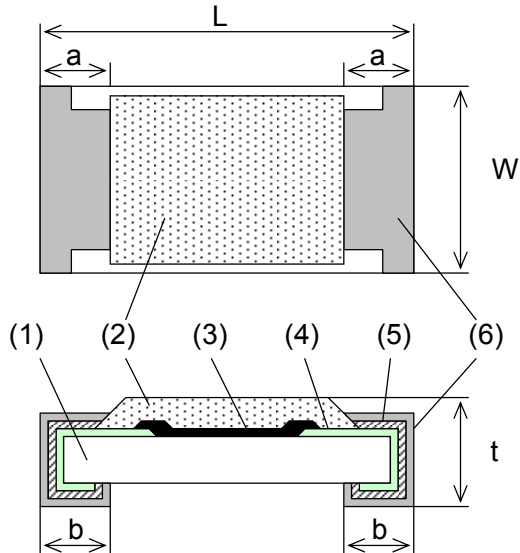

(1)	Substrate	Alumina
(2)	Protective coating	Epoxy resin
(3)	Resistive element	NiCr alloy
(4)	Inner termination	special termination
(5)	Between termination	Ni plating
(6)	Outer termination	Sn plating

	L	W	a	b	t
mm	$1.60 \pm 0.15$	$0.80 \pm 0.20$	$0.30 \pm 0.20$	$0.30 \pm 0.20$	$0.45 \pm 0.10$
inch	$0.63 \pm 0.006$	$.031 \pm 0.008$	$.012 \pm 0.008$	$.012 \pm 0.008$	$.018 \pm 0.004$

2. Power derating Curve

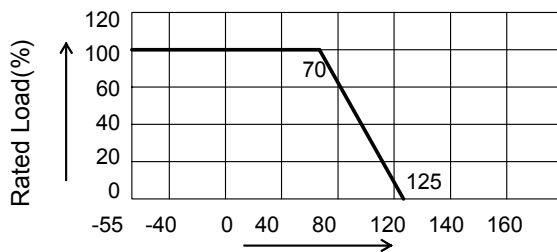

Category temperature range

-55~+125°C

Fig.1 Ambient Temperature (°C)

3. Ratings

Item	Rated value	Explanation
Rated power	0.10 W (at 70 °C or lower)	When used at ambient temperature over 70°C, the load power should be reduced as shown in Fig.1

Subject Metal Film(Thin Film) Chip Resistors PRODUCT SPECIFICATION FOR INFORMATION	Spec. No. 151-SRA-E102R
Part No. <b>ERA3</b>	10-2

Rated voltage & Limiting element voltage	The rated voltage of each resistance should be calculated from the equation below, and when the rated voltage exceeds the limiting element voltage, the limiting element voltage should be the rated voltage. $E = \sqrt{P \times R}$ Limiting element voltage ;75V E : Rated voltage (V) P : Rated power (W) R : Rated resistance value (Ω)											
Tolerance for resistance	<table border="1"> <tr> <th>Code.</th> <th>Tolerance for resis.</th> </tr> <tr> <td>D</td> <td>± 0.5%</td> </tr> <tr> <td>B</td> <td>± 0.1%</td> </tr> </table>			Code.	Tolerance for resis.	D	± 0.5%	B	± 0.1%			
Code.	Tolerance for resis.											
D	± 0.5%											
B	± 0.1%											
Resistance range	<table border="1"> <tr> <th>Tolerance</th> <th>Resistance range</th> <th>Series</th> </tr> <tr> <td>D</td> <td>10 Ω ~330k Ω</td> <td>E-24</td> </tr> <tr> <td>B</td> <td>100Ω ~33k Ω</td> <td>E-24</td> </tr> </table> E-96 series :special When E-96 series overlap E-24 series, E-24 series Should be the first priority			Tolerance	Resistance range	Series	D	10 Ω ~330k Ω	E-24	B	100Ω ~33k Ω	E-24
Tolerance	Resistance range	Series										
D	10 Ω ~330k Ω	E-24										
B	100Ω ~33k Ω	E-24										

#### 4. Explanation of Part Number

<b>E</b>	<b>R</b>	<b>A</b>	<b>3</b>	<b>Y</b>	<b>E</b>	<b>D</b>	<b>1</b>	<b>0</b>	<b>2</b>	<b>V</b>
(1)	(2)	(3)	(4)	(5)	(6)	(7)				

- (1) Product Code : Metal Film Chip Resistors  
(2) Size and Rated Power : 1.6 mm x 0.8 mm, 0.10W  
(3) Series and marking

Code	Series	Marking
Y	E-24 series	3 digit marking
E	E-96 series	No marking

- (4) T.C.R.

Code	T.C.R.	Resistance range
H	± 50x10 <sup>-6</sup> /°C	10Ω ~ 97.6Ω
E	± 25x10 <sup>-6</sup> /°C	100Ω ~ 33 kΩ
K	±100x10 <sup>-6</sup> /°C	33.2kΩ ~ 330kΩ

- (5) Resistance Tolerance

Code	Resistance Tolerance
D	+/- 0.5%
B	+/- 0.1%

- (6) Resistance Value

<E-24 series> 3-digits type 123 →12×10<sup>3</sup> →12kΩ  
<E-96 series> 4-digits type 3012 → 301×10<sup>2</sup> → 30.1kΩ

- (7) Packaging Configuration

Code	Packaging Configuration
V	Taping (5000pcs/reel)

Subject Metal Film(Thin Film) Chip Resistors PRODUCT SPECIFICATION FOR INFORMATION	Spec. No. 151-SRA-E102R
Part No. <b>ERA3</b>	10-3

### 5. Appearance & Construction

Item	Rated value	Explanation
Appearance & Construction		<ol style="list-style-type: none"> <li>The resistive element should be covered with protective coating that don't fade easily. The surface of coating should avoid unevenness, flaw, pinhole and discoloration.</li> <li>The electrode should be printed uniformly, as shown in the dimensions. The plating should not fade easily, and should avoid unevenness, flaw, pinhole, projection and discoloration.</li> <li>The electrode should be connected electrically, mechanically to resistive element.</li> </ol>

As far as there shall not designation especially, the following test and measurement shall be operated under normal temperature (15~35°C), normal humidity(25~75%), normal atmospheric pressure( $8.6 \times 10^4 \sim 1.06 \times 10^5$  Pa ).

### 6. Performance Specification

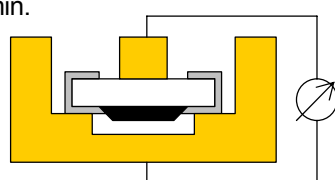
Item	Specifications		Explanation
	Chip Resistor		
DC Resistance	DC Resistance value shall be within the specified tolerance		At 20°C, 65%RH
Temperature Coefficient	Resit. range	TCR	Natural resistance change per Temperature degree centigrade. $\frac{R2 - R1}{R1(t2 - t1)} \times 10^6 \quad (10^{-6}/^{\circ}\text{C})$ R1 : Resistance value at reference temperature(t1) R2 : Resistance value at test temperature(t2) t2 - t1 = 100°C t1 = 25°C
	10Ω ~97.6Ω	± 50x10 <sup>-6</sup> /°C	
	100Ω ~33 kΩ	±25x10 <sup>-6</sup> /°C	
	33.2kΩ ~330kΩ	±100x10 <sup>-6</sup> /°C	
Short-time overload	± (0.5 % + 0.1Ω)		Resistors shall be applied 2.5 times the rated voltage for 5 seconds. However, the upper limit of the voltage in the test shall be 150V.
Dielectric Withstanding	No evidence of flashover, mechanical damage, arcing or insulation break-down		AC 100V between substrate and termination for 1 min.  AC powersupply or Insulation resistance
Insulation Resistance	Min. 1,000MΩ		Resistors shall be facing down. After applying DC 100V to the resistor, insulation resistance shall be measured.

Subject Metal Film(Thin Film) Chip Resistors PRODUCT SPECIFICATION FOR INFORMATION	Spec. No. 151-SRA-E102R
Part No. <b>ERA3</b>	10-4

7. Mechanical characteristic

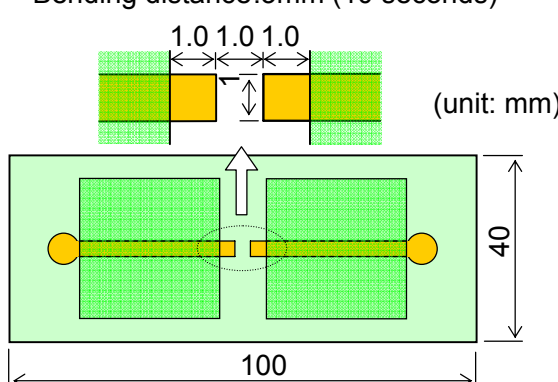
Item	Specifications	Explanation
	Chip Resistor	
Bond strength of the face plating	Without distinct deformation in appearance	Substrate : Glass epoxy(t=1.6mm) Span : 90mm Bending distance:3mm (10 seconds)  (unit: mm)
	$\pm (0.5 \% + 0.05\Omega)$	
Solderability	Termination should be covered uniformly with solder (min. 95% coverage)	Resistors shall be dipped in the melted solder bath at $235 \pm 5^\circ\text{C}$ for $2 \pm 0.5$ sec. Flux shall be removed from the surface of termination with clean organic solvent.
Resistance to Soldering Heat	$\pm (0.5 \% + 0.05\Omega)$	Resistors shall be dipped in the melted solder bath at $270 \pm 3^\circ\text{C}$ for $10 \pm 1$ sec.
Resistance to Solvent	Without distinct deformation in appearance	solvent solution : Isopropyl alcohol (1)Dipping 10 +/- 1 hours, dry in room condition for 30 +/- 10 minutes. (2)Ultrasonic wave washing : 5 +/- 1 min. (0.3W/cm <sup>2</sup> ,28kHz) Dry in room condition for 30 +/-10 minutes.
	$\pm (0.5 \% + 0.05\Omega)$	

Subject Metal Film(Thin Film) Chip Resistors PRODUCT SPECIFICATION FOR INFORMATION	Spec. No. 151-SRA-E102R
Part No. <b>ERA3</b>	10-5

### 8. Environment Test

Item	Specifications	Explanation
	Chip Resistor	
High Temperature Exposure	$\pm (0.5 \% + 0.05\Omega)$	Resistors shall be exposed at $125 \pm 3^\circ\text{C}$ for $1000 \pm_0^{48}$ hours.
Rapid change of temperature	$\pm (0.5 \% + 0.05\Omega)$	$-55 \pm 3^\circ\text{C}$ 30minutes $\downarrow\uparrow$ Normal Within 3minutes 5 cycles $\downarrow\uparrow$ $125 \pm 3^\circ\text{C}$ 30minutes
Damp heat , Steady State	$\pm (0.5 \% + 0.05\Omega)$	Resistors shall be exposed at $60 \pm 2^\circ\text{C}$ and 90~95% relative humidity in a humidity test chamber for $1000 \pm_0^{48}$ hours.
Load Life	$\pm (1.0 \% + 0.1\Omega)$	Resistors shall be exposed at $70 \pm 2^\circ\text{C}$ and $1000 \pm_0^{48}$ hours. During this time. The rated voltage shall be applied intermittently for 1.5 hours ON, 0.5 hours OFF.
Load Life in Humidity	$\pm (1.0 \% + 0.1\Omega)$	Resistors shall be exposed to at $40 \pm 2^\circ\text{C}$ and 90~95% relative humidity for $1000 \pm_0^{48}$ hours. During this time the rated voltage shall be applied intermittently for 1.5 hours ON, 0.5 hours OFF.

### 9. Marking

Express resistance value on resin side with three digits.  
(For example)

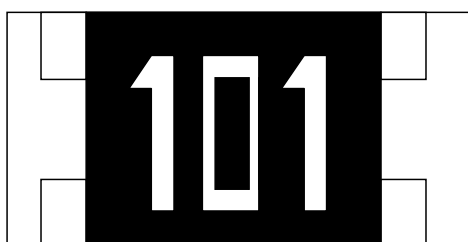

101 → 100Ω The first two digits are significant figures of resistance and the third one denotes number of zeros following.

★ E-96 series: No marking

Subject Metal Film(Thin Film) Chip Resistors PRODUCT SPECIFICATION FOR INFORMATION	Spec. No. 151-SRA-E102R
Part No. <b>ERA3</b>	10-6

## 10. Common Precautions in Handling Resistors

### Notice for use

- (1) This specification shows the quality and performance of a unit component. Before adoption, be sure to evaluate and verify the product mounting it in your product.
- (2) We take no responsibility for troubles caused by the product usage that is not specified in this specification.
- (3) In advance-notification to us is required in case you demand high reliability in the resistors because there is a possibility that a trouble or a failure in our resistor which is used in your transportation units (e.g. Trains, cars, ships, traffic signal equipment etc.), ocean floor-equipment, medical equipment, aerospace equipment, electrothermal goods, combustion and gas equipment, power station control equipment, information control equipment, rotating equipment, disaster and crime preventive equipment, various safety devices, and the equivalent equipment may cause critical damage occurrence such as loss of life or property.  
In addition, use fail-safe design as mentioned below for preventing extensive damage and for ensuring the safety:  
\*Ensure safety by the system in which the protective circuits and/or protective equipment are installed.  
\*Ensure safety by the system in which a single failure does not cause unsafety by installing such as redundant circuits.
- (4) When a dogma shall be occurred about safety for this product, be sure to inform us rapidly, operate your technical examination.
- (5) The product is designed to use in general standard applications of general electric equipment (AV products, household electric appliances, office equipment, information and communication equipment, etc.); hence, it do not take the use under the following special environments into consideration.  
Accordingly, the use in the following special environments, and such environmental conditions may affect the performance of the product: prior to use, verify the performance, reliability, etc. thoroughly.
  - 1) Use in liquids such as water, oil, chemical, and organic solvent.
  - 2) Use under direct sunlight, in outdoor or in dusty atmospheres.
  - 3) Use in places full of corrosive gases such as sea breeze, Cl<sub>2</sub>, H<sub>2</sub>S, NH<sub>3</sub>, SO<sub>2</sub>, and NO<sub>x</sub>.
  - 4) Use in environment with large static electricity or strong electromagnetic waves or strong radial ray.
  - 5) Where the product is close to a heating component, or where an inflammable such as a polyvinyl chloride wire is arranged close to the product.
  - 6) Where the resistor is sealed or coated with resin etc.
  - 7) Where solvent, water, or water-soluble detergent is used in cleaning free soldering and in flux cleaning after soldering. (Pay particular attention to water-soluble flux.)
  - 8) Use in such a place where the product is wetted due to dew condensation.
- (6) If transient load (heavy load in a short time) like pulse is expected to be applied, carry out evaluation and confirmation test with resistors actually mounted on your own board.  
When the load of more than rated power is applied under the load condition at steady state, it may impair performance and/or reliability of resistor. Never exceed the rated power and rated voltage. Temperature of resistors may become high even with specified conditions. Please confirm safety of heat from resistors on print circuit board and components around them. When the product shall be used under special condition, be sure to ask us in advance.
- (7) Halogen type (Chlorine type, Bromine type, etc.) or other high-activity flux is not recommended as the residue may affect performance or reliability of resistors.  
Strong acid flux, water soluble-flux and flux including fluorine ion shall not be used.
- (8) When soldering with soldering iron, never touch the body of the chip resistor with a tip of the soldering iron. When using a soldering iron with a tip at high temperature, solder for a time as short as possible. (three seconds or less up to 350 deg.C)
- (9) Avoid physical shock to the resistor and nipping of the resistor with hard tool (a pair of pliers or tweezers) as it may damage protective film or the body of resistor and may affect resistor's performance.
- (10) Avoid immersion of chip resistor in solvent for long time. Use solvent after the effect of immersion is confirmed.

Subject Metal Film(Thin Film) Chip Resistors PRODUCT SPECIFICATION FOR INFORMATION	Spec. No. 151-SRA-E102R
Part No. <b>ERA3</b>	10-7

#### 11. Storage Method

If the product is stored in the following environments and conditions, the performance and solderability may be badly affected, avoid the storage in the following environments.

- (1) Storage in places full of corrosive gases such as sea breeze, Cl<sub>2</sub>, H<sub>2</sub>S, NH<sub>3</sub>, SO<sub>2</sub>, and NO<sub>x</sub>.
- (2) Storage in places exposed to direct sunlight.
- (3) Storage in places outside the temperature range of 5 °C to 35 °C and humidity range of 45 %RH to 85 %RH.
- (4) The period of guarantee for performance such as solderability is 1 year after our delivery; and this condition applies only to the case where the storage method specified in item (1) to (3) has been followed.

#### 12. Laws and Regulations

- (1) This product has not been manufactured with any ozone-depleting chemical controlled under the Montreal Protocol.
- (2) This product complies with the RoHS Directive (Restriction of the use of certain Hazardous substances in electrical and electronic equipment (DIRECTIVE 2002/95/EC)).
- (3) All materials used in this part are registered material under the Law Concerning the examination and Regulation of Manufactures, etc. of Chemical substances.
- (4) All the materials used in this part contain no brominated materials of PBBO<sub>3</sub> or PBB<sub>5</sub> as the flame-retardant.
- (5) If you need the notice by letter of "A preliminary judgement on the laws of Japan foreign exchange and foreign trade control", be sure to let us know.

#### 13. Production Site

Country: Japan

Plant: Panasonic Electronic Devices Japan Co., Ltd.

Subject Metal Film(Thin Film) Chip Resistors PRODUCT SPECIFICATION FOR INFORMATION	Spec. No. 151-SRA-E102R
Part No. <b>ERA3</b>	10-8

14. Tape and Reel Package

14.1 Structure and reel dimensions shall be as shown in the figure below.  
In accordance with EIAJ ET-7200.

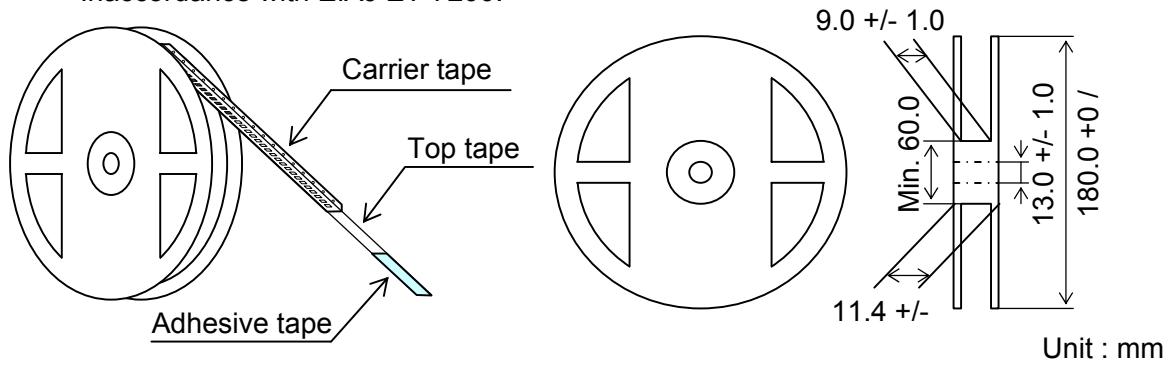

14.2 Carrier Tape Dimensions

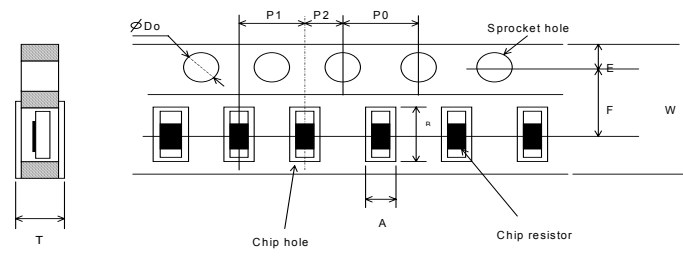

	A	B	W	F	E
(mm)	1.10±0.10	1.90±0.10	8.00±0.20	3.50±0.05	1.75±0.10
(inch)	.043±.004	.074±.004	.314±.008	.137±.002	.069±.004

	P1	P2	P0	∅ D0	T
(mm)	4.00±0.10	2.00±0.05	4.00±0.10	1.50 ± <sub>0</sub> <sup>0.10</sup>	0.70±0.05
(inchi)	.157±.004	.079±.002	.157±.004	.059 ± <sub>0</sub> <sup>.004</sup>	.028±.002

14.3 Tapping specifications

14.3.1 Taping

(1) Minimum Bending Radius

There shall be no deflection of chip and no breakage of carrier tape in case carrier tape have been bent by minimum bending radius (15mm). Test shall be conducted for 1 time.

(2) Resistance to climate of top tape

The top tape shall not tear off after exposure at 60 °C, 90 %RH to 95 %RH for 120 h.

(3) Peeling strength

Peeling strength shall be within 0.049 N to 0.49 N. There shall be no burr or breakage after test. Test method is as follows:

Subject Metal Film(Thin Film) Chip Resistors PRODUCT SPECIFICATION FOR INFORMATION	Spec. No. 151-SRA-E102R
Part No. <b>ERA3</b>	10-9

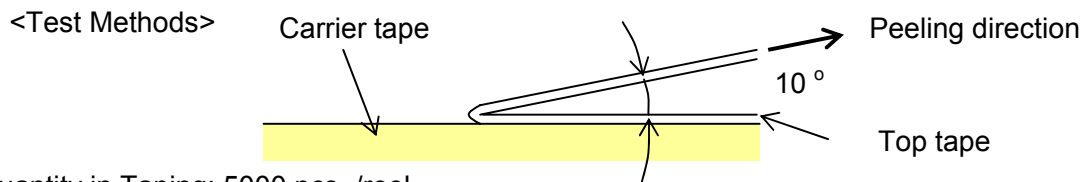

14.3.2 Quantity in Taping: 5000 pcs. /reel

#### 14.3.3 Tape packaging

- (1) Resistance side shall be facing upward.
- (2) Chip resistor shall not be sticking to top tape and bottom tape.
- (3) Chip resistor shall be easy to take out from carrier tape and chip hole or sprocket hole shall not have flash and break.

#### 14.4 Outer Packaging

Quantity: 20 reels (Max. 100,000pcs.)

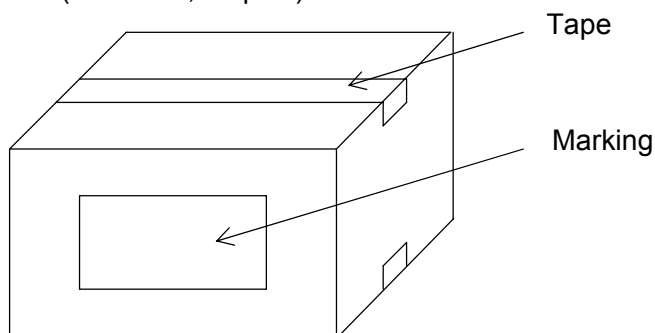

\* When taping shall not reach Max. or quantity, the remaining empty space shall be buried with buffer material.

\* When the quantity shall be few, alternative packaging methods may be used. No problem must occur during the exportation of the product.

#### 14.5 Marking (Label)

Items listed below shall be displayed.

- (1) Side of reel (Marking shall be on one side)
  - 1)Part name, 2)Part number, 3)Quantity, 4)Lot number, 5)Maker name, 6) Production country
- (2)Packaging box
  - 1)Customer name, 2)Part name, 3)Part number, 4)Customer part number, 5)Quantity.
  - 6)Maker name, 7)Production country

## Looking for pricing, stock, or lifecycle information?

Click below to explore more details on WIN SOURCE:

- ⊖ [View ERA-3EEB1871V on WIN SOURCE](#)
- ⊖ [Panasonic Information](#)

## Optimize Your Supply Chain with WIN SOURCE Solutions

- ✓ Global Sourcing Solution
- ✓ Obsolete Management
- ✓ Cost Control Management
- ✓ Shortage Management
- ✓ Alternative Solution
- ✓ Excess Inventory Management