

**WIN***SOURCE*  
ELECTRONICS  
**THE DATASHEET OF**  
**IR2.510S**

win-source.net



0086-755-83957316

MODEL NO.	"L"	"H"	"W"	P/N
IR2.5.8S	9	1.50	.010	20111
IR2.51.5S	18	1.50	.010	17835
IR2.510S	120	1.50	.010	20041
IR2.51S	12	1.50	.010	17834
IR2.52.2S	26	1.50	.010	20167
IR2.52S	24	1.50	.010	17965
IR2.54S	48	1.50	.010	17964
IR2.55S	60	1.50	.010	20130
IR2.53S	36	1.50	.010	17332

NOTES:

1. 'M600' SUFFIX INDICATES THAT FIBERS POTTED ON RECTANGULAR END WITH EPOXY THAT OPERATES IN MAX. TEMPERATURE OF 600°F.

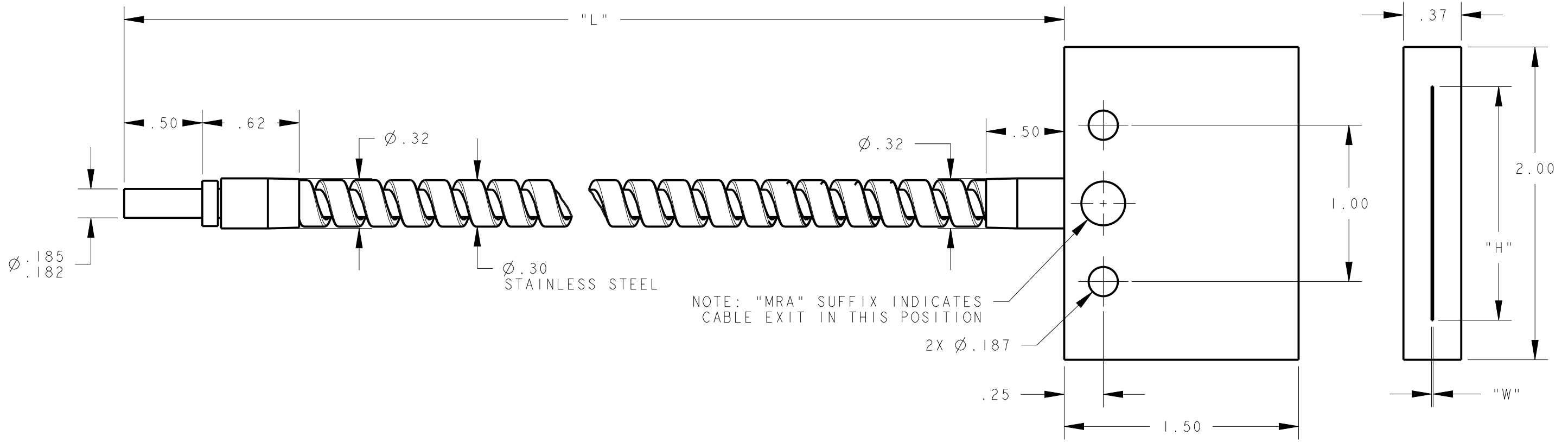

NOTE: "MRA" SUFFIX INDICATES CABLE EXIT IN THIS POSITION

NOTES:  
 1. ALL DIMENSIONS ARE MILLIMETERS [INCHES] UNLESS OTHERWISE NOTED.  
 2. REFER TO "www.bannerengineering.com" FOR ADDITIONAL DATA AND SPECIFICATIONS.

This drawing is the property of BANNER ENGINEERING CORP. Any use or reproduction, in any form, without prior written permission of Banner is prohibited. © 2015 Banner Engineering Corp.



BANNER ENGINEERING CORP.  
 www.bannerengineering.com

THIRD ANGLE PROJECTION

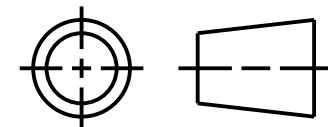

TITLE  
**IR2 SERIES SS TERMINATED**

SIZE B	DRAWING NO. <b>161914</b>	REV. <b>A</b>
SCALE 3:2	SHEET 1 OF 2	

CREO

8	7	6	5	4	3	2	1		
MODEL NO.	"L"	"H"	"W"	P/N	MODEL NO.	"L"	"H"	"W"	P/N
IR2.53SMRA	36	1.50	.010	17333	IR2.520S	240	1.50	.010	16849
IR2.53SM.09X.21	36	.21	.090	20681	IR2.58S.43X.01RA	96	.433	.010	12395
IR2.53SMI.25	36	1.25	.015	17832	IR2.58SMI.25MRA	96	1.25	.015	10626
IR2.53SMI	36	1.00	.019	17366	IA2.57SM600	84	1.50	.010	00000
IR2.510SM600	120	1.50	.010	20555	IR2.51.5SMRA	18	1.50	.010	22950
IR2.56S	72	1.50	.010	21322	IR2.51.5SMI	18	1.00	.019	00000
IR2.530S	360	1.50	.010	21217	IR2.53.33S	40	1.50	.010	00000
IR2.5.7S	8	1.50	.010	20112	IR23SM.79X.01	36	.79	.010	24493
IR2.5.83S	10	1.50	.010	20168	IR2.51.7S	20	1.50	.010	23910

IR2.56.5S	78	1.50	.010	00000
IR2.51SMI	12	1.00	.019	00000
IR2.56SM.5X.03RA	72	.55	.035	00000
IR2.56SM600	72	1.50	.010	24681
IR2.515S	180	1.50	.010	74256
IR2.52.7S	32	1.50	.010	24684
IR2.51.2S	14	1.50	.010	24685
IR2.56SMI	72	1.00	.019	24837
IR2.54SM.79X.01	48	.79	.010	71658
IR2.59S	108	1.50	.010	22579
IR2.53SM600M.6	36	.60	.03	22075
IR2.53SM.5X.03RA	36	.55	.035	22011
IR2.58S	96	1.50	.010	21406
IR2.53SM600	36	1.50	.010	21352

NOTES:  
 1. ALL DIMENSIONS ARE MILLIMETERS [INCHES] UNLESS OTHERWISE NOTED.  
 2. REFER TO "www.bannerengineering.com" FOR ADDITIONAL DATA AND SPECIFICATIONS.

This drawing is the property of BANNER ENGINEERING CORP. Any use or reproduction, in any form, without prior written permission of Banner is prohibited.  
 © 2015 Banner Engineering Corp.

THIRD ANGLE PROJECTION

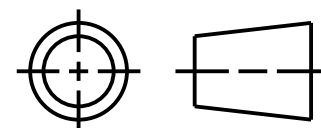

**BANNER** BANNER ENGINEERING CORP.  
 www.bannerengineering.com

TITLE  
**IR2 SERIES SS TERMINATED**

SIZE B DRAWING NO. **161914** REV. **A**

SCALE 3:2 SHEET 2 OF 2

## Looking for pricing, stock, or lifecycle information?

Click below to explore more details on WIN SOURCE:

[View IR2.510S on WIN SOURCE](#)

[Banner Engineering Corporation](#) Information

## Optimize Your Supply Chain with WIN SOURCE Solutions

- ✓ Global Sourcing Solution
- ✓ Obsolete Management
- ✓ Cost Control Management
- ✓ Shortage Management
- ✓ Alternative Solution
- ✓ Excess Inventory Management