



**THE DATASHEET OF
IR3504MTRPBF**



***xPHASE3™* AMD SVID CONTROL IC**

DESCRIPTION

The IR3504 Control IC combined with an *xPHASE3™* Phase IC provides a full featured and flexible way to implement a complete AMD SVID power solution. It provides outputs for both the VDD core and VDDNB auxiliary planes required by the CPU. The IR3504 provides overall system control and interfaces with any number of Phase ICs each driving and monitoring a single phase. The *xPHASE3™* architecture results in a power supply that is smaller, less expensive, and easier to design while providing higher efficiency than conventional approaches.

FEATURES

- 2 converter outputs for the AMD processor VDD core and VDDNB auxiliary planes
- AMD Serial VID interface independently programs both output voltages and operation
- Both Converter Outputs boot to 2-bit “Boot” VID codes which are read and stored from the SVC & SVD parallel inputs upon the assertion of the Enable input
- PWROK input signal activates SVID after successful boot start-up
- Both Converter Outputs can be independently turned on and off through SVID commands
- Deassertion of PWROK prior to Enable causes the converter output to transition to the stored Pre-PWROK VID codes
- Connecting the PWROK input to VCCL disables SVID and implements VFIX mode with both output voltages programmed via SVC & SVD parallel inputs per the 2 bit VFIX VID codes
- PG monitors output voltage, PG will deassert if either output voltage out of spec
- 0.5% overall system set point accuracy
- Programmable Dynamic VID Slew Rates
- Programmable VID Offset (VDD output only)
- Programmable output impedance (VDD output only)
- High speed error amplifiers with wide bandwidth of 20MHz and fast slew rate of 10V/us
- Remote sense amplifiers provide differential sensing and require less than 50uA bias current
- Programmable per phase switching frequency of 250kHz to 1.5MHz
- Daisy-chain digital phase timing provides accurate phase interleaving without external components
- Hiccup over current protection with delay during normal operation
- Central over voltage detection and communication to phase ICs through IIN (ISHARE) pin
- OVP disabled during dynamic VID down to prevent false triggering
- Detection and protection of open remote sense lines
- Gate Drive and IC bias linear regulator control with programmable output voltage and UVLO
- Simplified Power Good (PG) Output provides indication of proper operation and avoids false triggering
- Small thermally enhanced 32L MLPQ (5mm x 5mm) package
- Over voltage signal to system with over voltage detection during powerup and normal operation

ORDERING INFORMATION

Device	Package	Order Quantity
IR3504MTRPBF	32 Lead MLPQ (5 x 5 mm body)	3000 per reel
* IR3504MPBF	32 Lead MLPQ (5 x 5 mm body)	100 piece strips

* Samples only

APPLICATION CIRCUIT

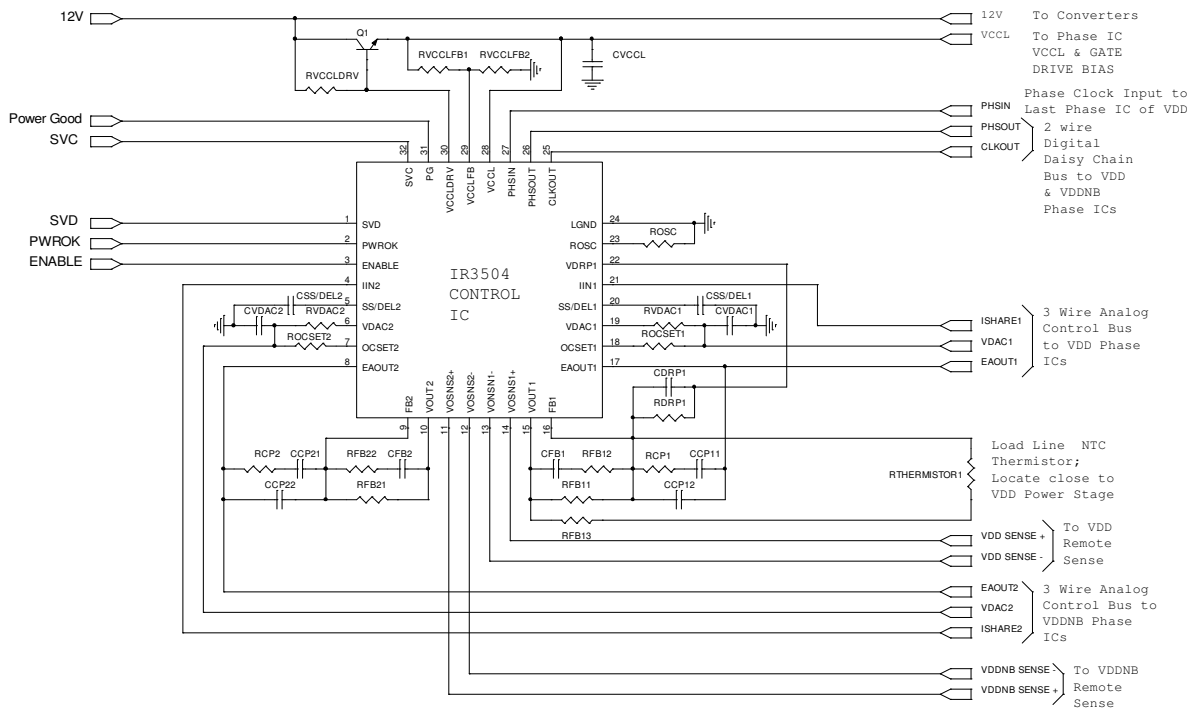

Figure 1 – IR3504 Application Circuit

PIN DESCRIPTION

PIN#	PIN SYMBOL	PIN DESCRIPTION
1	SVD	SVD (Serial VID Data) is a bidirectional signal that is an input and open drain output for both master (AMD processor) and slave (IR3504), requires an external bias voltage and should not be floated
2	PWROK	System wide Power Good signal and input to the IR3504. When asserted, the IR3504 output voltage is programmed through the SVID interface protocol. Connecting this pin to VCCL enables VFIX mode.
3	ENABLE	Enable input. A logic low applied to this pin puts the IC into fault mode. A logic high on the pin enables the converter and causes the SVC and SVD input states to be decoded and stored, determining the 2-bit Boot VID. Do not float this pin as the logic state will be undefined.
4	IIN2	Output 2 average current input from the output 2 phase IC(s). This pin is also used to communicate over voltage condition to the output 2 phase ICs.
5	SS/DEL2	Programs output 2 startup and over current protection delay timing. Connect an external capacitor to LGND to program.
6	VDAC2	Output 2 reference voltage programmed by the SVID inputs and error amplifier non-inverting input. Connect an external RC network to LGND to program dynamic VID slew rate and provide compensation for the internal buffer amplifier.
7	OCSET2	Programs the output 2 constant converter output current limit and hiccup over-current threshold through an external resistor tied to VDAC2 and an internal current source from this pin. Over-current protection can be disabled by connecting a resistor from this pin to VDAC2 to program the threshold higher than the possible signal into the IIN2 pin from the phase ICs but no greater than 5V (do not float this pin as improper operation will occur).

PIN#	PIN SYMBOL	PIN DESCRIPTION
8	EAOUT2	Output of the output 2 error amplifier.
9	FB2	Inverting input to the Output 2 error amplifier.
10	VOOUT2	Output 2 remote sense amplifier output.
11	VOSEN2+	Output 2 remote sense amplifier input. Connect to output at the load.
12	VOSEN2-	Output 2 remote sense amplifier input. Connect to ground at the load.
13	VOSEN1-	Output 1 remote sense amplifier input. Connect to ground at the load.
14	VOSEN1+	Output 1 remote sense amplifier input. Connect to output at the load.
15	VOOUT1	Output 1 remote sense amplifier output.
16	FB1	Inverting input to the output 1 error amplifier. Converter output voltage can be increased from the VDACC1 voltage with an external resistor connected between VOOUT1 and this pin (there is an internal current sink at this pin).
17	EAOUT1	Output of the output 1 error amplifier.
18	OCSET1	Programs the output 1 constant converter output current limit and hiccup over-current threshold through an external resistor tied to VDACC1 and an internal current source from this pin. Over-current protection can be disabled by connecting a resistor from this pin to VDACC1 to program the threshold higher than the possible signal into the IIN1 pin from the phase ICs but no greater than 5V (do not float this pin as improper operation will occur).
19	VDACC1	Output 1 reference voltage programmed by the SVID inputs and error amplifier non-inverting input. Connect an external RC network to LGND to program dynamic VID slew rate and provide compensation for the internal buffer amplifier.
20	SS/DEL1	Programs output 1 startup and over current protection delay timing. Connect an external capacitor to LGND to program.
21	IIN1	Output 1 average current input from the output 1 phase IC(s). This pin is also used to communicate over voltage condition to phase ICs.
22	VDRP1	Output 1 Buffered IIN1 signal. Connect an external RC network to FB1 to program converter output impedance.
23	ROSC/OVP	Connect a resistor to LGND to program oscillator frequency and OCSET1, OCSET2, FB1, FB2, VDACC1, and VDACC2 bias currents. Oscillator frequency equals switching frequency per phase. The pin voltage is 0.6V during normal operation and higher than 1.6V if over-voltage condition is detected.
24	LGND	Local Ground for internal circuitry and IC substrate connection.
25	CLKOUT	Clock output at switching frequency multiplied by phase number. Connect to CLKIN pins of phase ICs.
26	PHSOUT	Phase clock output at switching frequency per phase. Connect to PHSIN pin of the first phase IC.
27	PHSIN	Feedback input of phase clock. Connect to PHSOUT pin of the last phase IC.
28	VCCL	Output of the voltage regulator, and power input for clock oscillator circuitry. Connect a decoupling capacitor to LGND.
29	VCCLFB	Non-inverting input of the voltage regulator error amplifier. Output voltage of the regulator is programmed by the resistor divider connected to VCCL.
30	VCCLDRV	Output of the VCCL regulator error amplifier to control external transistor. The pin senses 12V power supply through a resistor.
31	PG	Power good signal implemented with an open collector output that drives low during startup and under any external fault condition. Also, if any of the voltage planes fall out of spec, it will drive low. Connect external pull-up. (Output voltage out of spec is defined as 350mV to 240mV below VDACC voltages)
32	SVC	SVC (Serial VID Clock) is an open drain output of the processor and input to IR3504, requires an external bias voltage and should not be floated

ABSOLUTE MAXIMUM RATINGS

Absolute maximum ratings indicate sustained limits beyond which damage to the device may occur. All voltages are absolute voltages referenced to the LGND pin.

Operating Junction Temperature.....0 to 150°C
 Storage Temperature Range.....-65°C to 150°C
 ESD Rating.....HBM Class 1C JEDEC Standard
 MSL Rating.....2
 Reflow Temperature.....260°C

PIN #	PIN NAME	V _{MAX}	V _{MIN}	I _{SOURCE}	I _{SINK}
1	SVD	8V	-0.3V	1mA	10mA
2	PWROK	8V	-0.3V	1mA	1mA
3	ENABLE	3.5V	-0.3V	1mA	1mA
4	IIN2	8V	-0.3V	5mA	1mA
5	SS/DEL2	8V	-0.3V	1mA	1mA
6	VDAC2	3.5V	-0.3V	1mA	1mA
7	OCSET2	8V	-0.3V	1mA	1mA
8	EAOUT2	8V	-0.3V	25mA	10mA
9	FB2	8V	-0.3V	1mA	1mA
10	VOUT2	8V	-0.3V	5mA	25mA
11	VOSEN2+	8V	-0.5V	5mA	1mA
12	VOSEN2-	1.0V	-0.5V	5mA	1mA
13	VOSEN1-	1.0V	-0.5V	5mA	1mA
14	VOSEN1+	8V	-0.5V	5mA	1mA
15	VOUT1	8V	-0.3V	5mA	25mA
16	FB1	8V	-0.3V	1mA	1mA
17	EAOUT1	8V	-0.3V	25mA	10mA
18	OCSET1	8V	-0.3V	1mA	1mA
19	VDAC1	3.5V	-0.3V	1mA	1mA
20	IIN1	8V	-0.3V	5mA	1mA
21	SS/DEL1	8V	-0.3V	1mA	1mA
22	VDRP1	8V	-0.3V	35mA	1mA
23	ROSC/OVP	8V	-0.3V	1mA	1mA
24	LGND	n/a	n/a	20mA	1mA
25	CLKOUT	8V	-0.3V	100mA	100mA
26	PHSOUT	8V	-0.3V	10mA	10mA
27	PHSIN	8V	-0.3V	1mA	1mA
28	VCCL	8V	-0.3V	1mA	20mA
29	VCCLFB	3.5V	-0.3V	1mA	1mA
30	VCCLDRV	10V	-0.3V	1mA	50mA
31	PG	VCCL + 0.3V	-0.3V	1mA	20mA
32	SVC	8V	-0.3V	1mA	1mA

RECOMMENDED OPERATING CONDITIONS FOR RELIABLE OPERATION WITH MARGIN
 $4.75V \leq VCCL \leq 7.5V$, $-0.3V \leq VOSEN-x \leq 0.3V$, $0^\circ C \leq T_j \leq 100^\circ C$, $7.75 k\Omega \leq ROSC \leq 50 k\Omega$, $CSS/DELx = 0.1\mu F$

ELECTRICAL CHARACTERISTICS

The electrical characteristics involve the spread of values guaranteed within the recommended operating conditions (unless otherwise specified). Typical values represent the median values, which are related to 25°C.

PARAMETER	TEST CONDITION	MIN	TYP	MAX	UNIT
SVID Interface					
SVC & SVD Input Thresholds	Threshold Increasing (Note 1)	0.850	0.950	1.05	V
	Threshold Decreasing (Note 1)	550	650	750	mV
	Threshold Hysteresis (Note 1)	195	300	405	mV
Bias Current	$0V \leq V(x) \leq 3.5V$, SVD not asserted	-5	0	5	μA
SVD Low Voltage	$I(SVD) = 3mA$		20	300	mV
SVD Output Fall Time	$0.7 \times VDDIO$ to $0.3VDDIO$, $1.425V \leq VDDIO \leq 1.9V$, $10 pF \leq C_b \leq 400 pF$, $C_b = \text{capacitance of one bus line (Note 1)}$	$20 + 0.1 \times C_b(pF)$		250	ns
Pulse width of spikes suppressed by the input filter	Note 1	97	260	410	ns
Oscillator					
PHSOUT Frequency		-10%	See Figure 2	+10%	kHz
ROSC Voltage		0.57	0.600	0.630	V
CLKOUT High Voltage	$I(CLKOUT) = -10 mA$, measure $V(VCCL) - V(CLKOUT)$.			1	V
CLKOUT Low Voltage	$I(CLKOUT) = 10 mA$			1	V
PHSOUT High Voltage	$I(PHSOUT) = -1 mA$, measure $V(VCCL) - V(PHSOUT)$			1	V
PHSOUT Low Voltage	$I(PHSOUT) = 1 mA$			1	V
PHSIN Threshold Voltage	Compare to $V(VCCL)$	30	50	70	%
VDRP1 Buffer Amplifier					
Input Offset Voltage	$V(VDRP1) - V(IIN1)$, $0.5V \leq V(IIN) \leq 3.3V$	-8	0	8	mV
Source Current	$0.5V \leq V(IIN1) \leq 3.3V$	2		30	mA
Sink Current	$0.5V \leq V(IIN1) \leq 3.3V$	0.2	0.4	0.6	mA
Unity Gain Bandwidth	Note 1		8		MHz
Slew Rate	Note 1		4.7		V/ μs
IIN Bias Current		-1	0	1	μA
Remote Sense Differential Amplifiers					
Unity Gain Bandwidth	Note 1	3.0	6.4	9.0	MHz
Input Offset Voltage	$0.5V \leq V(VOSENx+) - V(VOSENx-) \leq 1.6V$, Note 2	-3	0	3	mV
Source Current	$0.5V \leq V(VOSENx+) - V(VOSENx-) \leq 1.6V$	0.5	1	1.7	mA
Sink Current	$0.5V \leq V(VOSENx+) - V(VOSENx-) \leq 1.6V$	2	12	16	mA
Slew Rate	$0.5V \leq V(VOSENx+) - V(VOSENx-) \leq 1.6V$	2	4	8	V/ μs
VOSEN+ Bias Current	$0.5 V < V(VOSENx+) < 1.6V$		30	50	μA
VOSEN- Bias Current	$-0.3V \leq VOSENx- \leq 0.3V$, All VID Codes		30	55	μA
VOSEN+ Input Voltage Range	$V(VCCL) = 7V$			5.5	V
Low Voltage	$V(VCCL) = 7V$			250	mV
High Voltage	$V(VCCL) - V(VOUTx)$		0.5	1	V
Soft Start and Delay					
Start Delay	Measure Enable to EAOUTx activation	1	2.9	3.5	ms
Start-up Time	Measure Enable activation to PG	3	8	13	ms

PARAMETER	TEST CONDITION	MIN	TYP	MAX	UNIT
OC Delay Time	$V(IINx) - V(OCSETx) = 500\text{ mV}$	300	650	1000	us
SS/DELx to FBx Input Offset Voltage	With FBx = 0V, adjust V(SS/DELx) until EAOUTx drives high	0.7	1.4	1.9	V
Charge Current		-30	-50	-70	μA
OC Delay/VID Off Discharge Currents	Note 1		47		μA
Fault Discharge Current		2.5	4.5	6.5	μA
Hiccup Duty Cycle	$I(\text{Fault}) / I(\text{Charge})$	8	10	12	uA/uA
Charge Voltage		3.5	3.9	4.2	V
Delay Comparator Threshold	Relative to Charge Voltage, SS/DELx rising Note 1		80		mV
Delay Comparator Threshold	Relative to Charge Voltage, SS/DELx falling Note 1		130		mV
Delay Comparator Hysteresis	Note 1		60		mV
Discharge Comp. Threshold		150	200	300	mV
Over-Current Comparators					
Input Offset Voltage	$1\text{V} \leq V(OCSETx) \leq 3.3\text{V}$	-30	0	30	mV
OCSET Bias Current		-5%	$\frac{V_{rosc}(V) \cdot 1000}{ROSC(K\Omega)}$	+5%	μA
2048-4096 Count Threshold	Adjust ROSC value to find threshold		11.4		kΩ
1024-2048 Count Threshold	Adjust ROSC value to find threshold		32.5		kΩ
Error Amplifiers					
System Set-Point Accuracy (Deviation from Table 1, 2, and 3 per test circuit in Figures 2A & 2B)	VID > 1.0V	-0.65		0.65	%
	$0.8\text{V} \leq \text{VID} \leq 1.0\text{V}$	-8		+8	mV
	$0.5\text{V} \leq \text{VID} < 0.8\text{V}$	-9		+9	mV
Input Offset Voltage	Measure $V(\text{FBx}) - V(\text{VDACx})$. Note 2	-1	0	1	mV
FB1 Bias Current		-5%	$\frac{V_{rosc}(V) \cdot 1000}{ROSC(K\Omega)}$	+5%	μA
FB2 Bias Current		-1	0	1	μA
DC Gain	Note 1	100	110	135	dB
Bandwidth	Note 1	20	30	40	MHz
Slew Rate	Note 1	5.5	12	20	V/μs
Sink Current		0.4	0.85	1	mA
Source Current		6.0	8.5	13.0	mA
Maximum Voltage	Measure $V(\text{VCCL}) - V(\text{EAOUTx})$	500	780	950	mV
Minimum Voltage			120	250	mV
Open Control Loop Detection Threshold	Measure $V(\text{VCCL}) - V(\text{EAOUT})$, Relative to Error Amplifier maximum voltage.	125	300	600	mV
Open Control Loop Detection Delay	Measure PHSOUT pulse numbers from $V(\text{EAOUTx}) = V(\text{VCCL})$ to PG = low.		8		Pulses
Enable Input					
Blanking Time	Noise Pulse < 100ns will not register an ENABLE state change. Note 1	75	250	400	ns
VDAC References					
Source Currents	Includes $I(OCSETx)$	-8%	$\frac{3000 \cdot V_{rosc}(V)}{ROSC(k\Omega)}$	+8%	μA
Sink Currents	Includes $I(OCSETx)$	-12%	$\frac{1000 \cdot V_{rosc}(V)}{ROSC(k\Omega)}$	+12%	μA
PG Output					
Under Voltage Threshold - Voutx Decreasing	Reference to VDACCx	-365	-315	-265	mV
Under Voltage Threshold - Voutx Increasing	Reference to VDACCx	-325	-275	-225	mV
Under Voltage Threshold Hysteresis		5	53	110	mV

PARAMETER	TEST CONDITION	MIN	TYP	MAX	UNIT
Output Voltage	I(PG) = 4mA		150	300	mV
Leakage Current	V(PG) = 5.5V		0	10	μA
VCCL Activation Threshold	I(PG) = 4mA, V(PG) = 300mV		1.73	3.5	V
Over Voltage Protection (OVP) Comparators					
Threshold at Power-up		1.60	1.73	1.83	V
Voutx Threshold Voltage	Compare to V(VDACx)	190	240	280	mV
OVP Release Voltage during Normal Operation	Compare to V(VDACx)	-13	3	20	mV
Threshold during Dynamic VID down		1.79	1.84	1.89	V
Dynamic VID Detect Comparator Threshold	Note 1	25	50	75	mV
Propagation Delay to IIN	Measure time from V(Voutx) > V(VDACx) (250mV overdrive) to V(IINx) transition to > 0.9 * V(VCCL).		90	180	ns
OVP High Voltage	Measure V(VCCL)-V(ROSC/OVP)	0		1.2	V
OVP Power-up High Voltage	V(VCCLDRV)=1.8V. Measure V(VCCL)-V(ROSC/OVP)	0		0.2	V
Propagation Delay to OVP	Measure time from V(Voutx) > V(VDACx) (250mV overdrive) to V(ROSC/OVP) transition to >1V.		150	300	nS
IIN Pull-up Resistance			5	15	Ω
Open Sense Line Detection					
Sense Line Detection Active Comparator Threshold Voltage		150	200	250	mV
Sense Line Detection Active Comparator Offset Voltage	$V(Voutx) < [V(VOSENx+) - V(LGND)] / 2$	35	62.5	90	mV
VOSEN+ Open Sense Line Comparator Threshold	Compare to V(VCCL)	87	89.5	92	%
VOSEN- Open Sense Line Comparator Threshold		0.35	0.385	0.42	V
Sense Line Detection Source Currents	V(Voutx) = 100mV	200	500	700	μA
VCCL Regulator Amplifier					
Reference Feedback Voltage		1.15	1.2	1.25	V
VCCLFB Bias Current		-1	0	1	μA
VCCLDRV Sink Current		10	30		mA
UVLO Start Threshold	Compare to V(VCCL)	89.0	93.5	97.0	%
UVLO Stop Threshold	Compare to V(VCCL)	81.0	85.0	89.0	%
Hysteresis	Compare to V(VCCL)	7.0	8.25	9.5	%
ENABLE, PWROK Inputs					
Threshold Increasing		1.38	1.65	1.94	V
Threshold Decreasing		0.8	0.99	1.2	V
Threshold Hysteresis		470	620	770	mV
Bias Current	$0V \leq V(x) \leq 3.5V$, SVC not asserted	-5	0	5	μA
PWROK VFIX Mode Threshold		3.3V	$(VCCL + 3.3)(V) / 2$	VCCL	V
General					
VCCL Supply Current		4	10	15	mA

Note 1: Guaranteed by design, but not tested in production

Note 2: VDACx Outputs are trimmed to compensate for Error & Amp Remote Sense Amp input offsets

PHSOUT FREQUENCY VS RROSC CHART

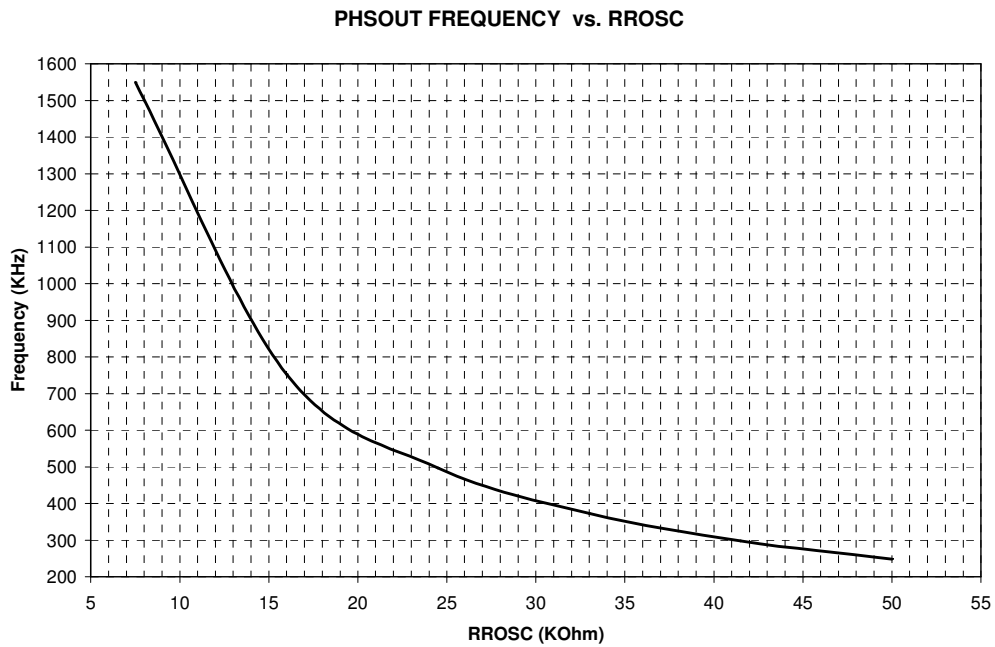

Figure 2 - Phout Frequency vs. RROSC chart

SYSTEM THEORY OF OPERATION

PWM Control Method

The PWM block diagram of the *xPHASE3™* architecture is shown in Figure 4. Feed-forward voltage mode control with trailing edge modulation is used. A high-gain wide-bandwidth voltage type error amplifier in the Control IC is used for the voltage control loop. Input voltage is sensed in phase ICs and feed-forward control is realized. The PWM ramp slope will change with the input voltage automatically compensating for changes in the input voltage. The input voltage can change due to variations in the silver box output voltage or due to the wire and PCB-trace voltage drop related to changes in load current.

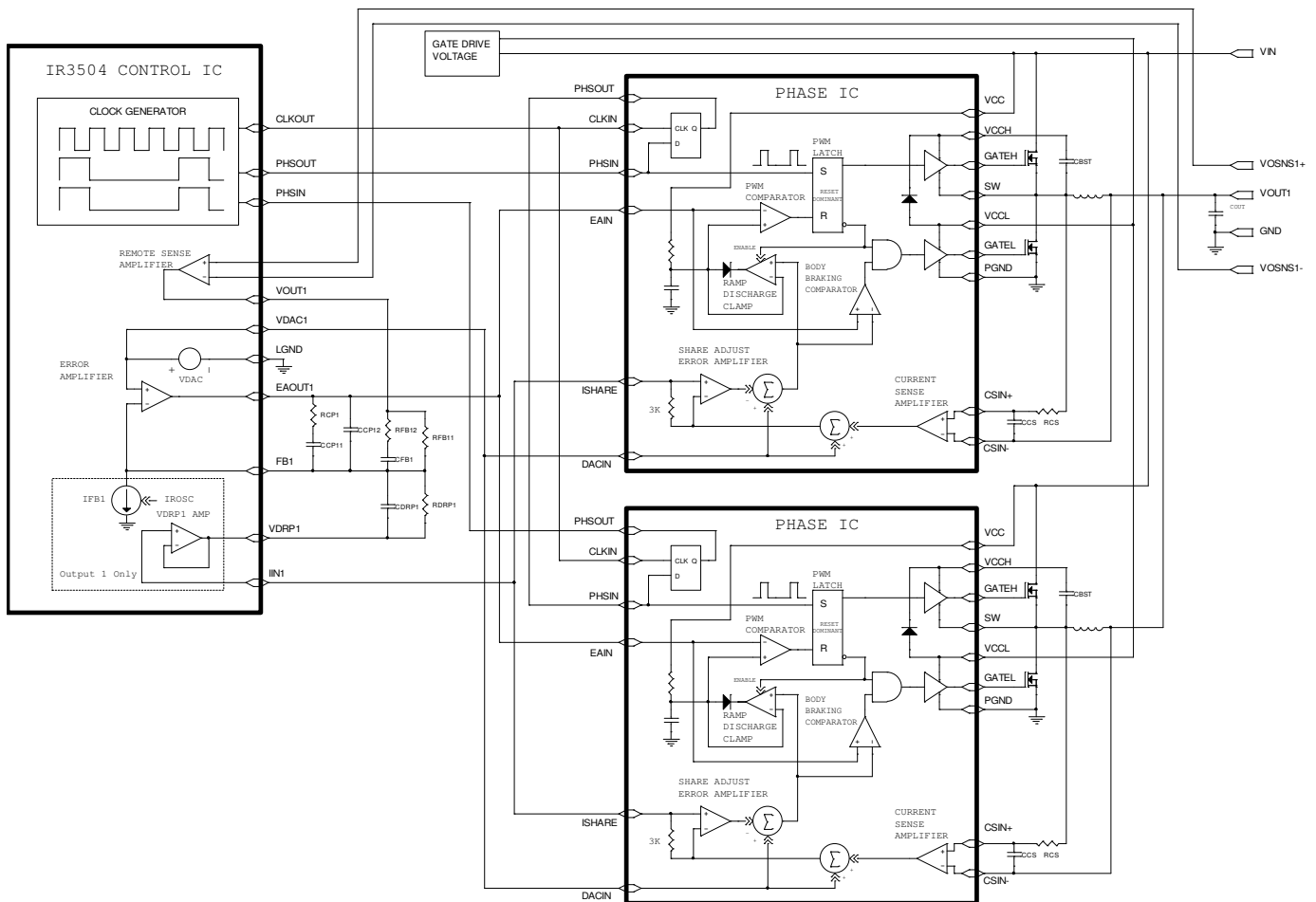

Figure 4 - PWM Block Diagram

Frequency and Phase Timing Control

The oscillator is located in the Control IC and the system clock frequency is programmable from 250 kHz to 9 MHz by an external resistor. The control IC system clock signal (CLKOUT) is connected to CLKIN of all the phase ICs. The phase timing of the phase ICs is controlled by the daisy chain loop, where control IC phase clock output (PHSOUT) is connected to the phase clock input (PHSIN) of the first phase IC, and PHSOUT of the first phase IC is connected to PHSIN of the second phase IC, etc. The last phase IC (PHSOUT) is connected back to PHSIN of the control IC to complete the loop. During power up, the control IC sends out clock signals from both CLKOUT and PHSOUT pins and detects the feedback at PHSIN pin to determine the phase number and monitors for any fault in the daisy chain loop. Figure 5 shows the phase timing for a four phase converter.

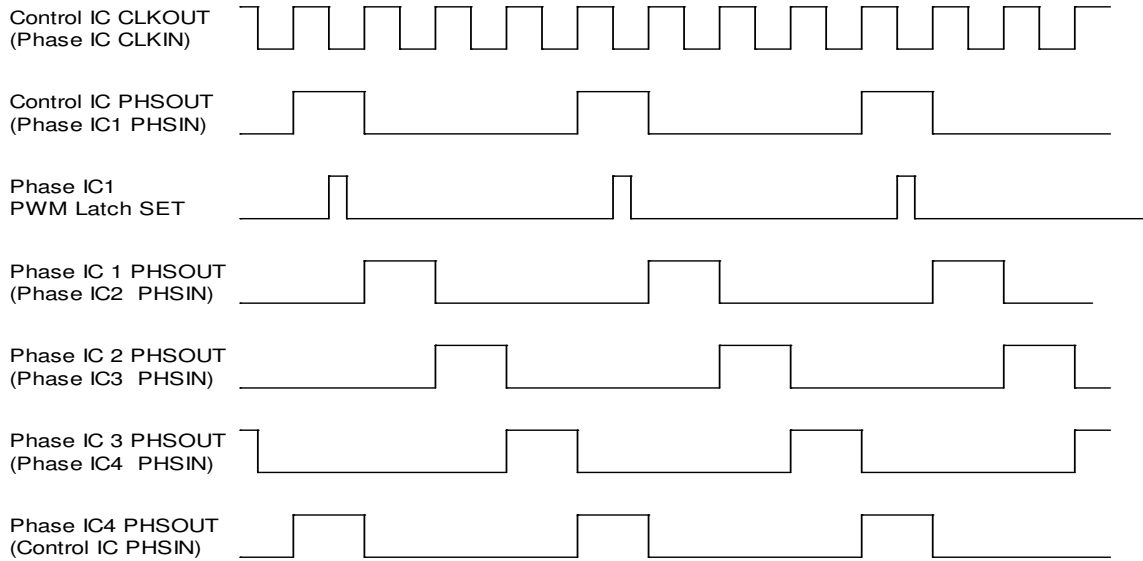

Figure 5 Four Phase Oscillator Waveforms

PWM Operation

The PWM comparator is located in the phase IC. Upon receiving the falling edge of a clock pulse, the PWM latch is set; the PWM ramp voltage begins to increase; the low side driver is turned off, and the high side driver is then turned on after the non-overlap time. When the PWM ramp voltage exceeds the error amplifier’s output voltage, the PWM latch is reset. This turns off the high side driver and then turns on the low side driver after the non-overlap time; it activates the ramp discharge clamp, which quickly discharges the internal PWM ramp capacitor to the output voltage of share adjust amplifier in phase IC until the next clock pulse.

The PWM latch is reset dominant allowing all phases to go to zero duty cycle within a few tens of nanoseconds in response to a load step decrease. Phases can overlap and go up to 100% duty cycle in response to a load step increase with turn-on gated by the clock pulses. An error amplifier output voltage greater than the common mode input range of the PWM comparator results in 100% duty cycle regardless of the voltage of the PWM ramp. This arrangement guarantees the error amplifier is always in control and can demand 0 to 100% duty cycle as required. It also favors response to a load step decrease which is appropriate given the low output to input voltage ratio of most systems. The inductor current will increase much more rapidly than decrease in response to load transients.

This control method is designed to provide “single cycle transient response” where the inductor current changes in response to load transients within a single switching cycle maximizing the effectiveness of the power train and minimizing the output capacitor requirements. An additional advantage of the architecture is that differences in ground or input voltage at the phases have no effect on operation since the PWM ramps are referenced to VDAC.

Figure 6 depicts PWM operating waveforms under various conditions.

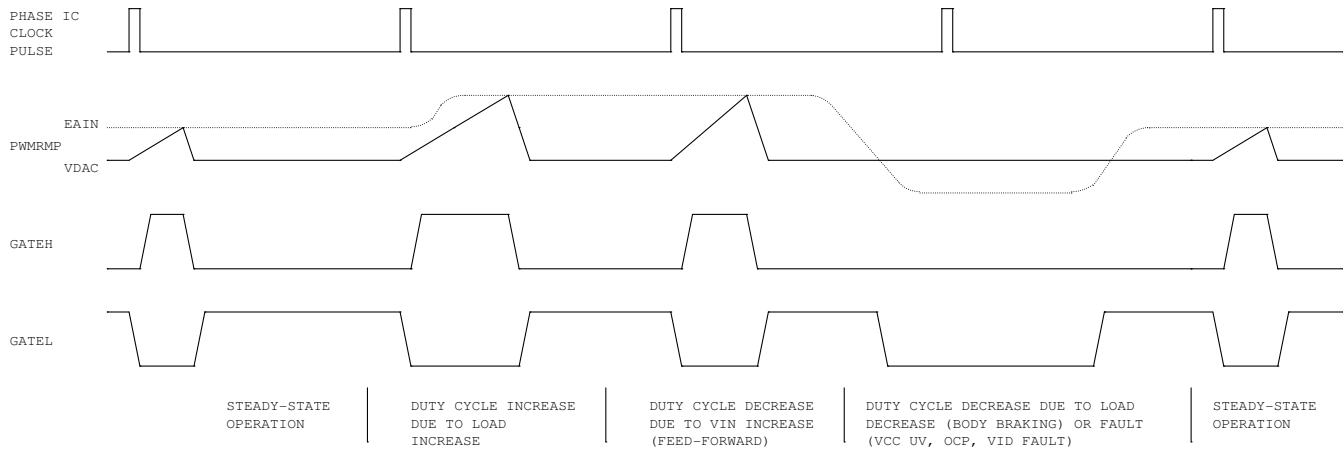

Figure 6 PWM Operating Waveforms

Body Braking™

In a conventional synchronous buck converter, the minimum time required to reduce the current in the inductor in response to a load step decrease is;

$$T_{SLEW} = \frac{L * (I_{MAX} - I_{MIN})}{V_O}$$

The slew rate of the inductor current can be significantly increased by turning off the synchronous rectifier in response to a load step decrease. The switch node voltage is then forced to decrease until conduction of the synchronous rectifier's body diode occurs. This increases the voltage across the inductor from V_{out} to $V_{out} + V_{BODYDIODE}$. The minimum time required to reduce the current in the inductor in response to a load transient decrease is now;

$$T_{SLEW} = \frac{L * (I_{MAX} - I_{MIN})}{V_O + V_{BODYDIODE}}$$

Since the voltage drop in the body diode is often higher than output voltage, the inductor current slew rate can be increased by 2X or more. This patent pending technique is referred to as "body braking" and is accomplished through the "body braking comparator" located in the phase IC. If the error amplifier's output voltage drops below the VDAC voltage or a programmable voltage, this comparator turns off the low side gate driver.

Lossless Average Inductor Current Sensing

Inductor current can be sensed by connecting a series resistor and a capacitor network in parallel with the inductor and measuring the voltage across the capacitor, as shown in Figure 7. The equation of the sensing network is,

$$v_C(s) = v_L(s) \frac{1}{1 + sR_{CS}C_{CS}} = i_L(s) \frac{R_L + sL}{1 + sR_{CS}C_{CS}}$$

Usually the resistor R_{CS} and capacitor C_{CS} are chosen so that the time constant of R_{CS} and C_{CS} equals the time constant of the inductor which is the inductance L over the inductor DCR (R_L). If the two time constants match, the voltage across C_{CS} is proportional to the current through L , and the sense circuit can be treated as if only a sense resistor with the value of R_L was used. The mismatch of the time constants does not affect the measurement of inductor DC current, but affects the AC component of the inductor current.

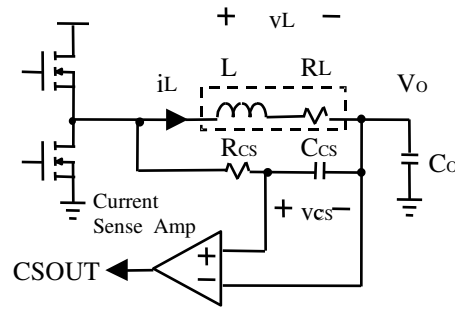

Figure 7 Inductor Current Sensing and Current Sense Amplifier

The advantage of sensing the inductor current versus high side or low side sensing is that actual output current being delivered to the load is obtained rather than peak or sampled information about the switch currents. The output voltage can be positioned to meet a load line based on real time information. Except for a sense resistor in series with the inductor, this is the only sense method that can support a single cycle transient response. Other methods provide no information during either load increase (low side sensing) or load decrease (high side sensing).

An additional problem associated with peak or valley current mode control for voltage positioning is that they suffer from peak-to-average errors. These errors will show in many ways but one example is the effect of frequency variation. If the frequency of a particular unit is 10% low, the peak to peak inductor current will be 10% larger and the output impedance of the converter will drop by about 10%. Variations in inductance, current sense amplifier bandwidth, PWM prop delay, any added slope compensation, input voltage, and output voltage are all additional sources of peak-to-average errors.

Current Sense Amplifier

A high speed differential current sense amplifier is located in the phase IC, as shown in Figure 7. Its gain is nominally 34 at 25°C, and the 3850 ppm/°C increase in inductor DCR should be compensated in the voltage loop feedback path.

The current sense amplifier can accept positive differential input up to 50mV and negative up to -10mV before clipping. The output of the current sense amplifier is summed with the DAC voltage and sent to the control IC and other phases through an on-chip 3KΩ resistor connected to the ISHARE pin. The ISHARE pins of all the phases are tied together and the voltage on the share bus represents the average current through all the inductors and is used by the control IC for voltage positioning and current limit protection.

Average Current Share Loop

Current sharing between phases of the converter is achieved by the average current share loop in each phase IC. The output of the current sense amplifier is compared with average current at the share bus. If current in a phase is smaller than the average current, the share adjust amplifier of the phase will pull down the starting point of the PWM ramp thereby increasing its duty cycle and output current; if current in a phase is larger than the average current, the share adjust amplifier of the phase will pull up the starting point of the PWM ramp thereby decreasing its duty cycle and output current. The current share amplifier is internally compensated so that the crossover frequency of the current share loop is much slower than that of the voltage loop and the two loops do not interact.

IR3504 THEORY OF OPERATION

Block Diagram

The Block diagram of the IR3504 is shown in Figure 8. The following discussions are applicable to either output plane unless otherwise specified.

Serial VID Control

The two Serial VID Interface (SVID) pins SVC and SVD are used to program the Boot VID voltage upon assertion of ENABLE while PWROK is de-asserted. See Table 1 for the 2-bit Boot VID codes. Both VDAC1 and VDAC2 voltages will be programmed to the Boot VID code until PWROK is asserted. The Boot VID code is stored by the IR3504 to be utilized again if PWROK is de-asserted.

Serial VID communication from the processor is enabled after the PWROK is asserted. Addresses and data are serially transmitted in 8-bit words. The IR3504 has three fixed addresses to control VDAC1, VDAC2, or both VDAC1 and VDAC2 (See Table 6 for addresses). The first data bit of the SVID data word represents the PSI_L bit and will be ignored by the IR3504 therefore this system will never enter a power-saving mode. The remaining data bits SVID[6:0] select the desired VDACx regulation voltage as defined in Table 3. SVID[6:0] are the inputs to the Digital-to-Analog Converter (DAC) which then provides an analog reference voltage to the transconductance type buffer amplifier. This VDACx buffer provides a system reference on the VDACx pin. The VDACx voltage along with error amplifier and remote sense differential amplifier input offsets are post-package trimmed to provide a 0.5% system set-point accuracy, as measured in Figures 3A and 3B. VDACx slew rates are programmable by properly selecting external series RC compensation networks located between the VDACx and the LGND pins. The VDACx source and sink currents are derived off the external oscillator frequency setting resistor, R_{ROSC} . The programmable slew rate enables the IR3504 to smoothly transition the regulated output voltage throughout VID transitions. This results in power supply input and output capacitor inrush currents along with output voltage overshoot to be well controlled.

The two Serial VID Interface (SVID) pins SVC and SVD can also program the VFIX VID voltage upon assertion of ENABLE while PWROK is equal to VCCL. See Table 2 for the 2-bit VFIX VID codes. Both VDAC1 and VDAC2 voltages will be programmed to the VFIX code.

The SVC and SVD pins require external pull-up biasing and should not be floated.

Output 1 (VDD) Adaptive Voltage Positioning

The IR3504 provides Adaptive Voltage Positioning (AVP) on the output1 plane only. AVP helps reduce the peak to peak output voltage excursions during load transients and reduces load power dissipation at heavy load. The circuitry related to the voltage positioning is shown in Figure 9. Resistor R_{FB1} is connected between the error amplifiers inverting input pin FB1 and the remote sense differential amplifier output, VOUT1. An internal current sink on the FB1 pin along with R_{FB1} provides programmability of a fixed offset voltage above the VDAC1 voltage. The offset voltage generated across R_{FB1} forces the converter's output voltage higher to maintain a balance at the error amplifiers inputs. The FB1 sink current is derived by the external resistor R_{ROSC} that programs the oscillator frequency.

The VDRP1 pin voltage is a buffered reproduction of the IIN1 pin which is connected to the current share bus ISHARE. The voltage on ISHARE represents the system average inductor current information. At each phase IC, an RC network across the inductor provides current information which is gained up 32.5X and then added to the VDACx voltage. This phase current information is provided on the ISHARE bus via a 3K resistor in the phase ICs.

Table 1 – 2-bit Boot VID codes

SVC	SVD	Output Voltage(V)
0	0	1.1
0	1	1.0
1	0	0.9
1	1	0.8

Table 2 – VFIX mode 2 bit VID Codes

SVC	SVD	Output Voltage(V)
0	0	1.4
0	1	1.2
1	0	1.0
1	1	0.8

Table 3 - AMD 7 BIT SVID CODES

SVID [6:0]	Voltage (V)	SVID [6:0]	Voltage (V)	SVID [6:0]	Voltage (V)	SVID [6:0]	Voltage (V)
000_0000	1.5500	010_0000	1.1500	100_0000	0.7500	110_0000	0.5000
000_0001	1.5375	010_0001	1.1375	100_0001	0.7375	110_0001	0.5000
000_0010	1.5250	010_0010	1.1250	100_0010	0.7250	110_0010	0.5000
000_0011	1.5125	010_0011	1.1125	100_0011	0.7125	110_0011	0.5000
000_0100	1.5000	010_0100	1.1000	100_0100	0.7000	110_0100	0.5000
000_0101	1.4875	010_0101	1.0875	100_0101	0.6875	110_0101	0.5000
000_0110	1.4750	010_0110	1.0750	100_0110	0.6750	110_0110	0.5000
000_0111	1.4625	010_0111	1.0625	100_0111	0.6625	110_0111	0.5000
000_1000	1.4500	010_1000	1.0500	100_1000	0.6500	110_1000	0.5000
000_1001	1.4375	010_1001	1.0375	100_1001	0.6375	110_1001	0.5000
000_1010	1.4250	010_1010	1.0250	100_1010	0.6250	110_1010	0.5000
000_1011	1.4125	010_1011	1.0125	100_1011	0.6125	110_1011	0.5000
000_1100	1.4000	010_1100	1.0000	100_1100	0.6000	110_1100	0.5000
000_1101	1.3875	010_1101	0.9875	100_1101	0.5875	110_1101	0.5000
000_1110	1.3750	010_1110	0.9750	100_1110	0.5750	110_1110	0.5000
000_1111	1.3625	010_1111	0.9625	100_1111	0.5625	110_1111	0.5000
001_0000	1.3500	011_0000	0.9500	101_0000	0.5500	111_0000	0.5000
001_0001	1.3375	011_0001	0.9375	101_0001	0.5375	111_0001	0.5000
001_0010	1.3250	011_0010	0.9250	101_0010	0.5250	111_0010	0.5000
001_0011	1.3125	011_0011	0.9125	101_0011	0.5125	111_0011	0.5000
001_0100	1.3000	011_0100	0.9000	101_0100	0.5000	111_0100	0.5000
001_0101	1.2875	011_0101	0.8875	101_0101	0.5000	111_0101	0.5000
001_0110	1.2750	011_0110	0.8750	101_0110	0.5000	111_0110	0.5000
001_0111	1.2625	011_0111	0.8625	101_0111	0.5000	111_0111	0.5000
001_1000	1.2500	011_1000	0.8500	101_1000	0.5000	111_1000	0.5000
001_1001	1.2375	011_1001	0.8375	101_1001	0.5000	111_1001	0.5000
001_1010	1.2250	011_1010	0.8250	101_1010	0.5000	111_1010	0.5000
001_1011	1.2125	011_1011	0.8125	101_1011	0.5000	111_1011	0.5000
001_1100	1.2000	011_1100	0.8000	101_1100	0.5000	111_1100	OFF
001_1101	1.1875	011_1101	0.7875	101_1101	0.5000	111_1101	OFF
001_1110	1.1750	011_1110	0.7750	101_1110	0.5000	111_1110	OFF
001_1111	1.1625	011_1111	0.7625	101_1111	0.5000	111_1111	OFF

Output 1 (VDD) Adaptive Voltage Positioning (continued)

The voltage difference between VDRP1 and FB1 represents the gained up average current information. Placing a resistor R_{DRP1} between VDRP1 and FB1 converts the gained up current information (in the form of a voltage) into a current forced onto the FB1 pin. This current, which can be calculated using $(VDRP1 - VDAC1) / R_{DRP1}$, will vary the offset voltage produced across R_{FB1} . Since the error amplifier will force the loop to maintain FB1 to equal the VDAC1 reference voltage, the output regulation voltage will be varied. When the load current increases, the adaptive positioning voltage $V(VDRP1)$ increases accordingly. $(VDRP1 - VDAC1) / R_{DRP1}$ increases the voltage drop across the feedback resistor R_{FB1} , and makes the output voltage lower proportional to the load current. The positioning voltage can be programmed by the resistor R_{DRP1} so that the droop impedance produces the desired converter output impedance. The offset and slope of the converter output impedance are referenced to VDAC1 and are not affected by changes in the VDAC1 voltage.

Output1 Inductor DCR Temperature Compensation

A negative temperature coefficient (NTC) thermistor can be used for output1 inductor DCR temperature compensation. The thermistor should be placed close to the output1 inductors and connected in parallel with the feedback resistor, as shown in Figure 10. The resistor in series with the thermistor is used to reduce the nonlinearity of the thermistor.

Remote Voltage Sensing

VOSEN_{x+} and VOSEN_{x-} are used for remote sensing and connected directly to the load. The remote sense differential amplifiers are high speed, have low input offset and low input bias currents to ensure accurate voltage sensing and fast transient response.

Start-up Sequence

The IR3504 has a programmable soft-start function to limit the surge current during the converter start-up. A capacitor connected between the SS/DEL_x and LGND pins controls soft start timing, over-current protection delay and hiccup mode timing. Constant current sources and sinks control the charge and discharge rates of the SS/DEL_x.

Figure 11 depicts the SVID start-up sequence. If the ENABLE input is asserted and there are no faults, the SS/DEL_x pin will begin charging, the pre-PWROK 2 bit Boot VID codes are read and stored, and both VDAC pins transition to the pre-PWROK Boot VID code. The error amplifier output EAOUT_x is clamped low until SS/DEL_x reaches 1.4V. The error amplifier will then regulate the converter's output voltage to match the $V(SS/DEL_x) - 1.4V$ offset until the converter output reaches the 2-bit Boot VID code. The SS/DEL_x voltage continues to increase until it rises above the threshold of Delay Comparator where the PG output is allowed to go high. The SVID interface is activated upon PWROK assertion and the VDAC_x along with the converter output voltage will change in response to any SVID commands.

VCCL under voltage, over current, or a low signal on the ENABLE input immediately sets the fault latch, which causes the EAOUT pin to drive low, thereby turning off the phase IC drivers. The PG pin also drives low and SS/DEL_x discharges to 0.2V. If the fault has cleared, the fault latch will be reset by the SS/DEL_x discharge comparator allowing another soft start charge cycle to occur.

Other fault conditions, such as output over voltage, open VOSNS sense lines, or an open phase timing daisy chain set a different group of fault latches that can only be reset by cycling VCCL power. These faults discharge SS/DEL_x, pull down EAOUT_x and drive PG low.

SVID OFF codes turn off the converter by discharging SS/DEL_x and pulling down EAOUT_x but do not drive PG low. Upon receipt of a non-off SVID code the converter will re-soft start and transition to the voltage represented by the SVID code as shown in Figure 11.

The converter can be disabled by pulling the SS/DEL_x pins below 0.6V.

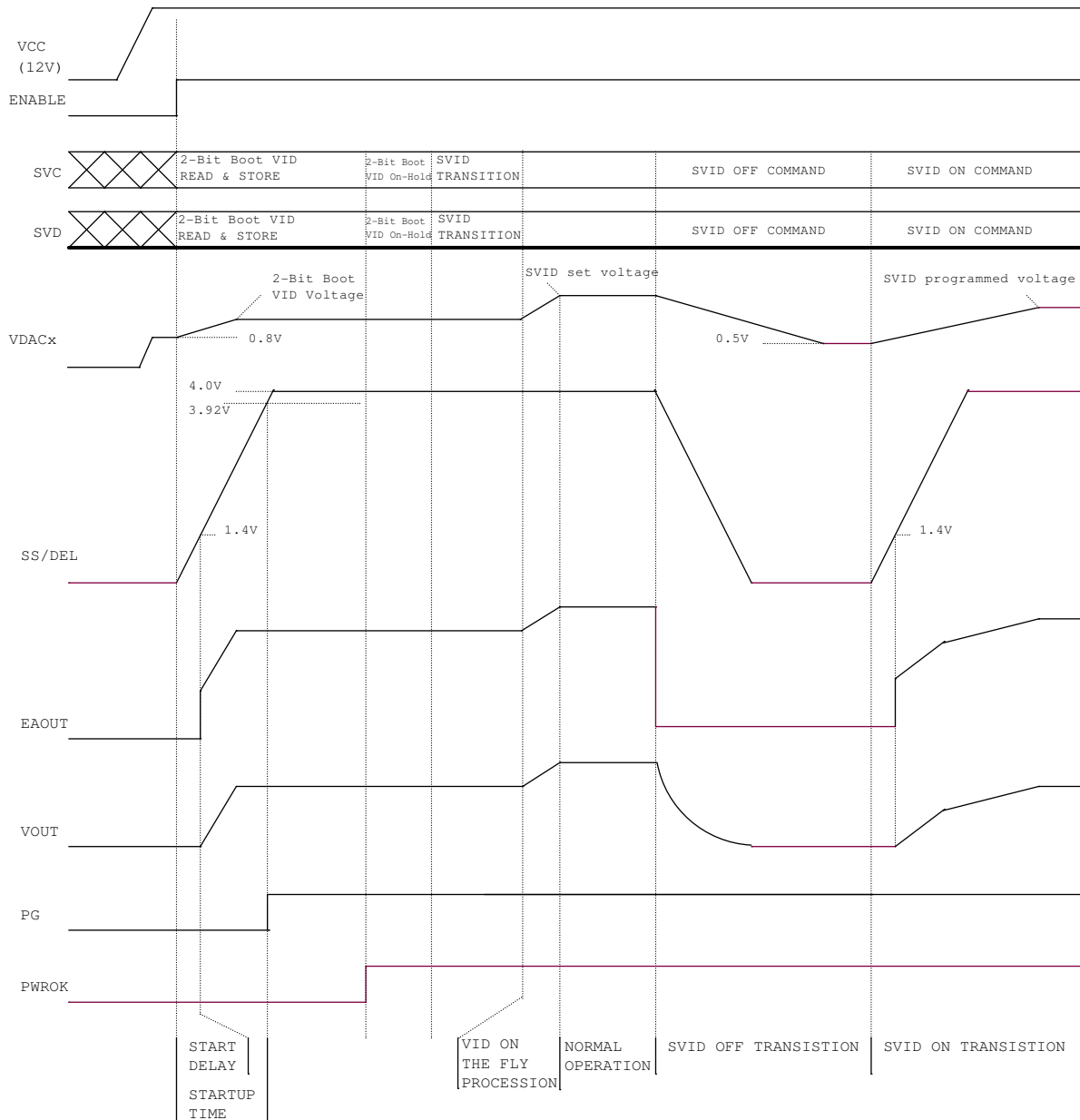

Figure 11 SVID Start-up Sequence Transitions

Serial VID Interface Protocol and VID-on-the-fly Transition

The IR3504 supports the AMD SVI bus protocol and the AMD Server and desktop SVI wire protocol which is based on fast-mode I²C. SVID commands from an AMD processor are communicated through SVID bus pins SVC and SVD. The SVC pin of the IR3504 does not have an open drain output since AMD SVID protocol does not support slave clock stretching.

The IR3504 transitions from a 2-bit Boot VID mode to SVI mode upon assertion of PWROK. The SMBus *send byte* protocol is used by the IR3504 VID-on-the-fly transactions. The IR3504 will wait until it detects a start bit which is defined as an SVD falling edge while SVC is high. A 7bit address code plus one write bit (low) should then follow the start bit. This address code will be compared against an internal address table and the IR3504 will reply with an acknowledge ACK bit if the address is one of the three stored addresses otherwise the ACK bit will not be sent out. The SVD pin is pulled low by the IR3504 to generate the ACK bit. Table 4 has the list of addresses recognized by the IR3504.

The processor should then transmit the 8-bit data word immediately following the ACK bit. Data bit 7 is the PSI_L bit which is followed by the 7Bit AMD code. The IR3504 replies again with an ACK bit once the data is received. If the received data is not a VID-OFF command, the IR3504 immediately changes the DAC analog outputs to the new target. VDACC1 and VDACC2 then slew to the new VID voltages. See Figure 12 for a send byte example.

Table 4 - SVI Send Byte Address Table

SVI Address [6:0] + Wr	Description
110xx100b	Set VID only on Output 1
110xx010b	Set VID only on Output 2
110xx110b	Set VID on both Output 1 and Output 2

Note: 'x' in the above Table 4 means the bit could be either '1' or '0'.

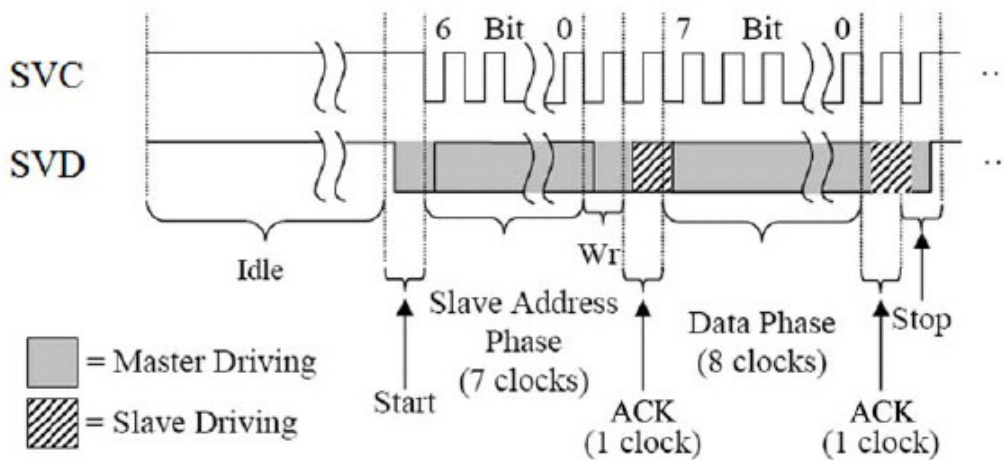

Figure 12 Send Byte Example

Over-Current Hiccup Protection after Soft Start

The over current limit threshold is set by a resistor connected between OCSET_x and VDACC_x pins. Figure 13 shows the hiccup over-current protection with delay after PG is asserted. The delay is required since over-current conditions can occur as part of normal operation due to load transients or VID transitions.

If the IIN_x pin voltage, which is proportional to the average current plus VDACC_x voltage, exceeds the OCSET_x voltage after PG is asserted, it will initiate the discharge of the capacitor at SS/DEL_x through the discharge current 47uA. If the over-current condition persists long enough for the SS/DEL_x capacitor to discharge below the 120mV offset of the delay comparator, the fault latch will be set which will then pull the error amplifier's output low to stop phase IC switching and will also de-asserting the PG signal. The SS/DEL capacitor will then continue to be discharged by a 4.5 uA current until it reaches 200 mV where the fault latch will reset to allow another soft start cycle to occur. The output current is not controlled during the delay time. If an over-current condition is again encountered during the soft start cycle, the over-current action will repeat and the converter will be in hiccup mode.

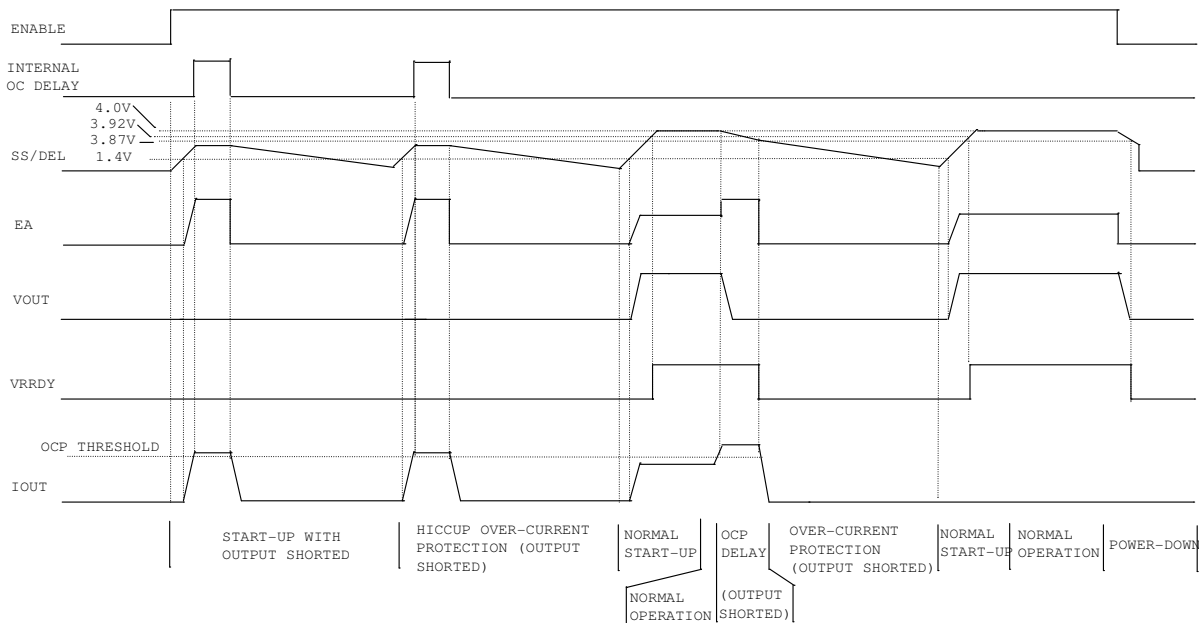

Figure 13 Hiccup over-current waveforms

Linear Regulator Output (VCCL)

The IR3504 has a built-in linear regulator controller, and only an external NPN transistor is needed to create a linear regulator. The output voltage of the linear regulator can be programmed between 4.75V and 7.5V by the resistor divider at VCCLFB pin. The regulator output powers the gate drivers and other circuits of the phase ICs along with circuits in the control IC, and the voltage is usually programmed to optimize the converter efficiency. The linear regulator can be compensated by a 4.7uF capacitor at the VCCL pin. As with any linear regulator, due to stability reasons, there is an upper limit to the maximum value of capacitor that can be used at this pin and it's a function of the number of phases used in the multiphase architecture and their switching frequency. Figure 14 shows the stability plots for the linear regulator with 5 phases switching at 750 kHz.

An external 5V can be connected to this pin to replace the linear regulator with appropriate selection of the VCCLFB resistor divider, and VCCLDRV resistor. When using an external VCCL, it's essential to adjust it such that VCCLFB is slightly less than the 1.19V reference voltage. This condition ensures that the VCCLDRV pin doesn't load the ROSC pin. The switching frequency, FB1 bias current, VDACC_x slew rate and OCSET point are derived from the loading current of ROSC pin.

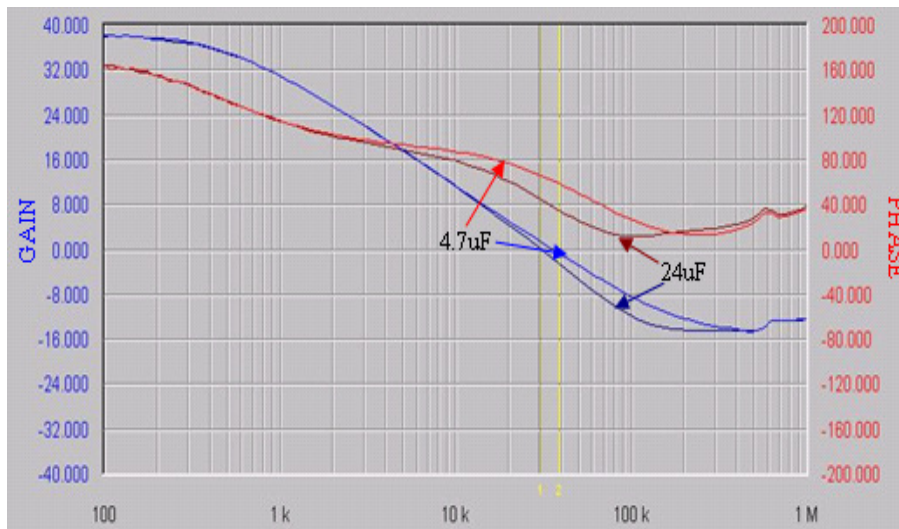

Figure 14 VCCL regulator stability with 5 phases and PHSOUT equals 750 kHz

VCCL Under Voltage Lockout (UVLO)

The IR3504 does not directly monitor VCC for under voltage lockout but instead monitors the system VCCL supply voltage since this voltage is used for the gate drive. As VCC begins to rise during power up, the VCCLDRV pin will be high impedance therefore allowing VCCL to roughly follow $VCC - NPN_{V_{BE}}$ until VCCL is above 94% of the voltage set by resistor divider at VCCLFB pin. At this point, the OV_x and UV CLEARED fault latches will be released. If VCCL voltage drops below 86% of the set value, the SS/DEL CLEARED fault latch will be set.

VID OFF Codes

SVID OFF codes of 111_1100, 111_1101, 111_1110, and 111_1111 turn off the converter by pulling down EAOUT_x voltage and discharging SS/DEL_x through the 50uA discharge current, but do not drive PG low. Upon receipt of a non-off SVID code the converter will turn on and transition to the voltage represented by the SVID as shown in Figure 10.

Voltage Regulator Ready (PG)

The PG pin is an open-collector output and should have an external pull-up resistor. During soft start, PG remains low until the output voltage is in regulation and SS/DEL_x is above 3.9V. The PG pin becomes low if ENABLE is low, VCCL is below 86% of target, an over current condition occurs for at least 1024 PHSOUT clocks prior to PG, an over current condition occurs after PG and SS/DEL_x discharges to the delay threshold, an open phase timing daisy chain condition occurs, VOSNS lines are detected open, VOUT_x is 315mV below VDAC_x, or if the error amp is sensed as operating open loop for 8 PHSOUT cycles. A high level at the PG pin indicates that the converter is in operation with no fault and ensures the output voltage is within the regulation.

PG monitors the output voltage. If any of the voltage planes fall out of regulation, PG will become low, but the VR continues to regulate its output voltages. The PWROK input may or may not de-assert prior to the voltage planes falling out of specification. Output voltage out of spec is defined as 315mV to 275mV below nominal voltage. VID on-the-fly transition which is a voltage plane transitioning between one voltage associated with one VID code and a voltage associated with another VID code is not considered to be out of specification.

A PWROK de-assert while ENABLE is high results in all planes regulating to the previously stored 2-bit Boot VID. If the 2-bit Boot VID is higher than the VID prior to PWROK de-assertion, this transition will NOT be treated as VID on-the-fly and if either of the two outputs is out of spec high, PG will be pulled down.

Open Control Loop Detection

The output voltage range of error amplifier is continuously monitored to ensure the voltage loop is in regulation. If any fault condition forces the error amplifier output above $VCCL-1.08V$ for 8 PHSOUT switching cycles, the fault latch is set. The fault latch can only be cleared by cycling the power to $VCCL$.

Load Current Indicator Output

The VDRP pin voltage represents the average current of the converter plus the DAC voltage. The load current information can be retrieved by using a differential amplifier to subtract $VDAC1$ voltage from the $VDRP1$ voltage.

Enable Input

Pulling the ENABLE pin below $0.8V$ sets the Fault Latch. Forcing ENABLE to a voltage above $1.94V$ results in the pre-PWROK 2 bit VID codes off the SVD and SVC pins to be read and stored. SS/DEL_x pins are also allowed to begin their power-up cycles.

Over Voltage Protection (OVP)

Output over-voltage might occur due to a high side MOSFET short or if the output voltage sense path is compromised. If the over-voltage protection comparators sense that either $VOUT_x$ pin voltage exceeds $VDAC_x$ by $240mV$, the over voltage fault latch is set which pulls the error amplifier output low to turn off the converter power stage. The IR3504 communicates an OVP condition to the system by raising the ROOSC/OVP pin voltage to within $V(VCCL) - 1.2 V$. An OVP condition is also communicated to the phase ICs by forcing the IIN pin (which is tied to the ISHARE bus and ISHARE pins of the phase ICs) to $VCCL$ as shown in Figure 15. In each phase IC, the OVP circuit overrides the normal PWM operation to ensure the low side MOSFET turn-on within approximately $150ns$. The low side MOSFET will remain on until the ISHARE pins fall below $V(VCCL) - 800mV$. An over voltage fault condition is latched in the IR3504 and can only be cleared by cycling the power to $VCCL$.

During dynamic VID down at light to no load, false OVP triggering is prevented by increasing the OVP threshold to a fixed $1.6V$ whenever a dynamic VID is detected and the difference between output voltage and the fast internal $VDAC$ is more than $50mV$, as shown in Figure 16. The over-voltage threshold is changed back to $VDAC+240mV$ if the difference between output voltage and the fast internal $VDAC$ is less than $50mV$.

The overall system must be considered when designing for OVP. In many cases the over-current protection of the AC-DC or DC-DC converter supplying the multiphase converter will be triggered thus providing effective protection without damage as long as all PCB traces and components are sized to handle the worst-case maximum current. If this is not possible, a fuse can be added in the input supply to the multiphase converter.

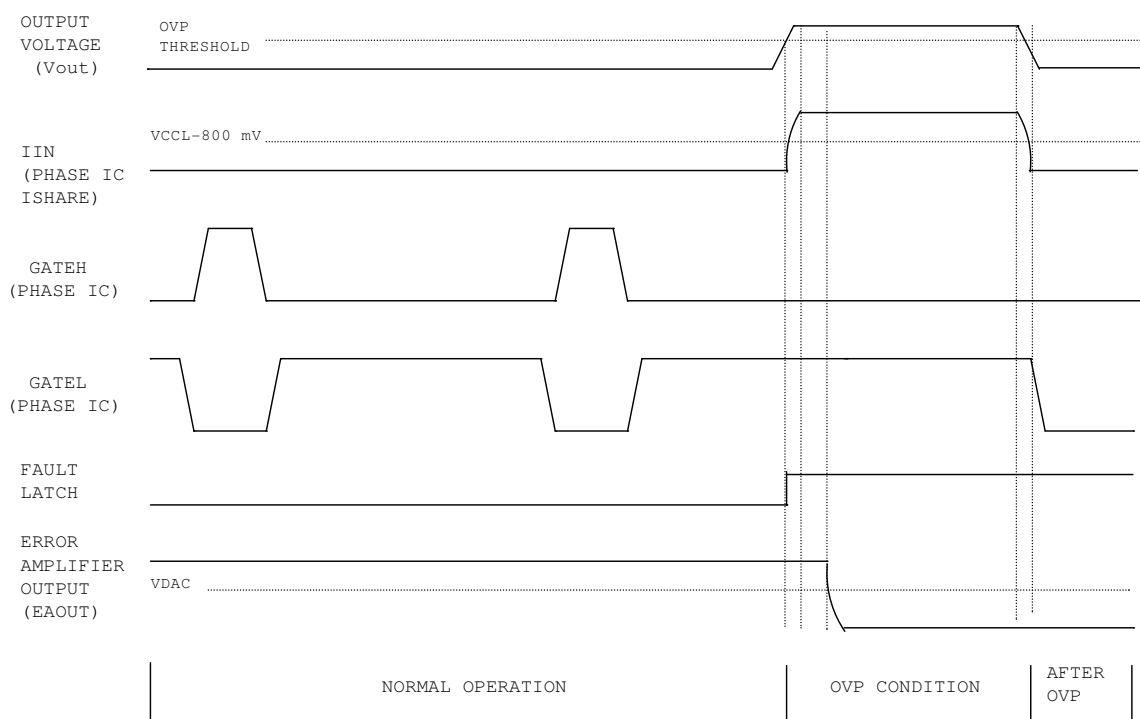

Figure 15 - Over-voltage protection during normal operation

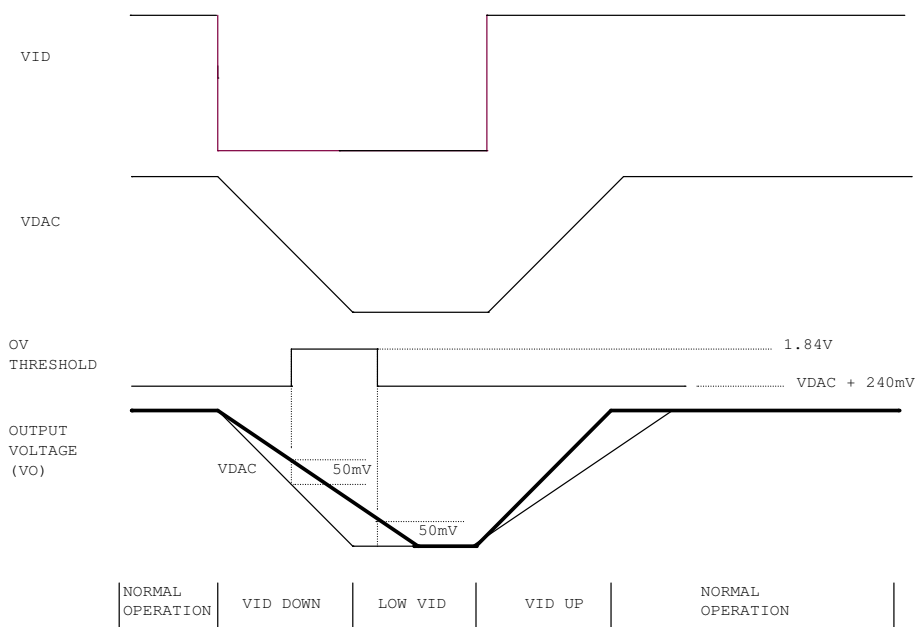

Figure 16 Over-voltage protection during dynamic VID

Open Remote Sense Line Protection

If either remote sense line $VOSEN_{x+}$ or $VOSEN_{x-}$ is open, the output of Remote Sense Amplifier ($VOUT_x$) drops. The IR3504 continuously monitors the $VOUT_x$ pin and if $VOUT_x$ is lower than 200 mV, two separate pulse currents are applied to the $VOSEN_{x+}$ and $VOSEN_{x-}$ pins to check if the sense lines are open. If $VOSEN_{x+}$ is open, a voltage higher than 90% of $V(VCC_L)$ will be present at $VOSEN_{x+}$ pin and the output of Open Line Detect Comparator will be high. If $VOSEN_{x-}$ is open, a voltage higher than 400mV will be present at $VOSEN_{x-}$ pin and the Open Line Detect Comparator output will be high. With either sense line open, the Open Sense Line Fault Latch will be set to force the error amplifier output low and immediately shut down the converter. SS/DEL_x will be discharged and the Open Sense Fault Latch can only be reset by cycling the power to VCC_L .

Open Daisy Chain Protection

The IR3504 checks the daisy chain every time it powers up. It starts a daisy chain pulse on the PHSOUT pin and detects the feedback at PHSIN pin. If no pulse comes back after 30 CLKOUT pulses, the pulse is restarted again. If the pulse fails to come back the second time, the Open Daisy Chain fault is registered, and SS/DEL_x is not allowed to charge. The fault latch can only be reset by cycling the power to VCC_L .

After powering up, the IR3504 monitors PHSIN pin for a phase input pulse equal or less than the number of phases detected. If PHSIN pulse does not return within the number of phases in the converter, another pulse is started on PHSOUT pin. If the second started PHSOUT pulse does not return on PHSIN, an Open Daisy Chain fault is registered.

Phase Number Determination

After a daisy chain pulse is started, the IR3504 checks the timing of the input pulse at PHSIN pin to determine the phase number.

The Fault Table below describes ten different faults that can occur during normal operation and how the IR3504 IC will react to protect the supply and the load from possible damage. The fault types that can occur are listed in row one. Row two and three describes type and the method of clearing the faults, respectively. The first four faults are latched in the UV fault and require the VCCL supply to be recycled (below UVLO threshold) to regain operation. The rest of the faults, except for UVLO Vout, are latched in a SS fault which do not need VCCL supply recycled, but instead will automatically resume operation when these fault conditions are no longer impinging on the system. Most of the faults will disable the error amplifier (EA) and discharge the soft start capacitor. All of the faults flag PGood. PGood returns to high impedance state (high) when the fault clears. The Delay row shows reaction time after detecting a fault condition. Delays are provided to minimize the possibility of nuisance faults. Additional flagged responses are used to communicate externally of a fault event (Over Voltage) so additional action can be taken.

System Fault Table

Fault Type	Open Daisy	Open Sense	Open Control	Over Voltage	Disable	VID_OFF SVID	UVLO (VCCL)	OC Before	OC After	UVLO (Vout)
<i>Latch</i>	UV Latch			SS Latch						No
<i>Fault Clearing Method</i>	Recycle VCCL			SS discharge below 0.2V						No
<i>Outputs Affected</i>	Both	Single		Both	Both	Single	Both	Single		Single
<i>Error Amp Disables</i>	Yes									No
<i>SS/DELx Discharge</i>	Yes									No
<i>Flags PGood</i>	Yes									
<i>Delays</i>	32 Clock Pulses	No	8 PHSOUT Pulses	No	250ns Blanking Time	No	No	PHSOUT Pulses*	SS/DELx Discharge Threshold	No
<i>Additional Flagged Response</i>	No			Yes, IINx and Rosc pins pulled-up to VCCL**	No					

* Pulse number range depends on Rosc value selected (See Specifications Table)

** Clears when OV condition ends

Table 5 Shows IR3504 system fault responses

DESIGN PROCEDURES - IR3504 AND IR3505 CHIPSET

IR3504 EXTERNAL COMPONENTS

All the output components are selected using one output but suitable for both unless otherwise specified.

Oscillator Resistor R_{ROSC}

The IR3504 generates square-wave pulses to synchronize the phase ICs. The switching frequency of the each phase converter equals the PHSOUT frequency, which is set by the external resistor R_{ROSC} , use Figure 2 to determine the R_{ROSC} value. The CLKOUT frequency equals the switching frequency multiplied by the phase number.

Soft Start Capacitor $C_{SS/DEL}$

The Soft Start capacitor $C_{SS/DEL}$ programs four different time parameters, soft start delay time, soft start time, VR ready delay time and over-current fault latch delay time after VR ready.

SS/DEL pin voltage controls the slew rate of the converter output voltage, as shown in Figure 11. Once the ENABLE pin rises above 1.65V, there is a soft-start delay time $TD1$ during which SS/DEL pin is charged from zero to 1.4V. Once SS/DEL reaches 1.4V the error amplifier output is released to allow the soft start. The soft start time $TD2$ represents the time during which converter voltage rises from zero to pre-PWROK VID voltage and the SS/DEL pin voltage rises from 1.4V to pre-PWROK VID voltage plus 1.4V. VR ready delay time $TD3$ is the time period from VR reaching the pre-PWROK VID voltage to the VR ready signal being issued.

Calculate $C_{SS/DEL}$ based on the required soft start time $TD2$.

$$C_{SS/DEL} = \frac{TD2 * I_{CHG}}{V_{pre-PWROK}} = \frac{TD2 * 50 * 10^{-6}}{V_{pre-PWROK}} \quad (1)$$

The soft start delay time $TD1$ and VR ready delay time $TD3$ are determined by equation (2) and (3) respectively.

$$TD1 = \frac{C_{SS/DEL} * 1.1}{I_{CHG}} = \frac{C_{SS/DEL} * 1.1}{50 * 10^{-6}} \quad (2)$$

$$TD3 = \frac{C_{SS/DEL} * (3.92 - V_{pre-PWROK} - 1.1)}{I_{CHG}} = \frac{C_{SS/DEL} * (3.92 - V_{pre-PWROK} - 1.1)}{50 * 10^{-6}} \quad (3)$$

Once $C_{SS/DEL}$ is chosen, use equation (4) to calculate the maximum over-current fault latch delay time t_{OCDEL} .

$$t_{OCDEL} = 2.5 * \frac{C_{SS/DEL} * 0.13}{I_{DISCHG}} = 2.5 * \frac{C_{SS/DEL} * 0.13}{47 * 10^{-6}} \quad (4)$$

Due to the exponential turn-on slope of the discharge current (47uA), a correction factor (X2.5) is added to the equation (4) to accurately predict over-current delay time.

VDAC Slew Rate Programming Capacitor C_{VDAC} and Resistor R_{VDAC}

The slew rate of VDAC down-slope SR_{DOWN} can be programmed by the external capacitor C_{VDAC} as defined in (5), where I_{SINK} is the sink current of VDAC pin. The slew rate of VDAC up-slope is three times greater than that of down-slope. The resistor R_{VDAC} is used to compensate VDAC circuit and is determined by (6).

$$C_{VDAC} = \frac{I_{SINK}}{SR_{DOWN}} \quad (5)$$

$$R_{VDAC} = 0.5 + \frac{3.2 * 10^{-15}}{C_{VDAC}^2} \quad (6)$$

Over Current Setting Resistor R_{OCSET}

The total input offset voltage (V_{CS_TOFST}) of current sense amplifier in phase ICs is the sum of input offset (V_{CS_OFST}) of the amplifier itself and that created by the amplifier input bias current flowing through the current sense resistor R_{CS} .

$$V_{CS_TOFST} = V_{CS_OFST} + I_{CSIN+} * R_{CS} \quad (7)$$

The inductor DC resistance is utilized to sense the inductor current. R_L is the inductor DCR.

The over current limit is set by the external resistor R_{OCSET} as defined in (9). I_{LIMIT} is the required over current limit. I_{OCSET} is the bias current of OCSET pin and can be calculated with the equation in the ELECTRICAL CHARACTERISTICS Table. G_{CS} is the gain of the current sense amplifier. K_P is the ratio of inductor peak current over average current in each phase and can be calculated from (10).

$$R_{OCSET} = \left[\frac{I_{LIMIT}}{n} * R_L * (1 + K_P) + V_{CS_TOFST} \right] * G_{CS} / I_{OCSET} \quad (9)$$

$$K_P = \frac{(V_I - V_O) * V_O / (L * V_I * f_{SW} * 2)}{I_O / n} \quad (10)$$

VCCL Programming Resistor $R_{VCCLFB1}$ and $R_{VCCLFB2}$

Since VCCL voltage is proportional to the MOSFET gate driver loss and inversely proportional to the MOSFET conduction loss, the optimum voltage should be chosen to maximize the converter efficiency. VCCL linear regulator consists of an external NPN transistor, a ceramic capacitor and a programmable resistor divider. Pre-select $R_{VCCLFB1}$, and calculate $R_{VCCLFB2}$ from (11).

$$R_{VCCLFB2} = \frac{R_{VCCLFB1} * 1.23}{VCCL - 1.23} \quad (11)$$

No Load Offset Setting Resistor R_{FB11} , R_{FB13} , R_{THERM1} and Adaptive Voltage Positioning Resistor R_{DRP11} for Output1

Define R_{FB_R} as the effective offset resistor at room temperature equals to $R_{FB11}/(R_{FB13}+R_{THERM1})$. Given the offset voltage V_{O_NLOFST} (offset above the DAC voltage) and calculating the sink current from the FB1 pin I_{FB1} using the equation in the ELECTRICAL CHARACTERISTICS Table, the effective offset resistor value, R_{FB1} , can be determined from (12).

$$R_{FB_R} = \frac{V_{O_NLOFST}}{I_{FB1}} \quad (12)$$

Adaptive voltage positioning lowers the converter voltage by $R_O \cdot I_O$ where R_O is the required output impedance of the converter. Pre-select feedback resistor R_{FB} and calculate the droop resistor R_{DRP} ,

$$R_{DRP11} = \frac{R_{FB_R} * R_{L_ROOM} * G_{CS}}{n * R_O} \quad (13)$$

Calculate the desired effective feedback resistor at the maximum temperature R_{FB_M} using (14).

$$R_{FB_M} = \frac{R_{DRP11} * R_O * n}{G_{CS} * R_{L_MAX}} \quad (14)$$

A negative temperature constant (NTC) thermistor R_{THERM1} is required to sense the temperature of the power stage for the inductor DCR thermal compensation. Pre-select the value of R_{THERM} . R_{THERM} must be bigger than R_{FB_R} at room temperature but also bigger than R_{FB_M} at the maximum allowed temperature. R_{TMAX1} is defined as the NTC thermistor resistance at maximum allowed temperature, T_{MAX} . R_{TMAX1} is calculated from (15).

$$R_{TMAX1} = R_{THERM1} * EXP[B_{THERM1} * (\frac{1}{T_{L_MAX}} - \frac{1}{T_{ROOM}})] \quad (15)$$

Select the series resistor R_{FB13} by using equation (16). R_{FB13} is incorporated to linearize the NTC thermistor which has non-linear characteristics in the operational temperature range.

$$R_{FB13} = \frac{\sqrt{(R_{THERM1} + R_{TMAX1})^2 - 4 * (R_{THERM1} * R_{TMAX1} - (R_{THERM1} - R_{TMAX1}) * R_{FB_R} * R_{FB_M}) / (R_{FB_R} - R_{FB_M})} - (R_{THERM1} + R_{TMAX1})}{2} \quad (16)$$

Use equation (17) to determine R_{FB11} .

$$\frac{1}{R_{FB11}} = \frac{1}{R_{FB_R}} - \frac{1}{R_{FB13} + R_{THERM1}} \quad (17)$$

IR3505 EXTERNAL COMPONENTS**Inductor Current Sensing Capacitor C_{CS} and Resistor R_{CS}**

The DC resistance of the inductor is utilized to sense the inductor current. Usually the resistor R_{CS} and capacitor C_{CS} in parallel with the inductor are chosen to match the time constant of the inductor, and therefore the voltage across the capacitor C_{CS} represents the inductor current. If the two time constants are not the same, the AC component of the capacitor voltage is different from that of the real inductor current. The time constant mismatch does not affect the average current sharing among the multiple phases, but affect the current signal I_{SHARE} as well as the output voltage during the load current transient if adaptive voltage positioning is adopted.

Measure the inductance L and the inductor DC resistance R_L . Pre-select the capacitor C_{CS} and calculate R_{CS} as follows.

$$R_{CS} = \frac{L/R_L}{C_{CS}} \quad (21)$$

Bootstrap Capacitor C_{BST}

Depending on the duty cycle and gate drive current of the phase IC, a capacitor in the range of 0.1 μ F to 1 μ F is needed for the bootstrap circuit.

Decoupling Capacitors for Phase IC

0.1 μ F-1 μ F decoupling capacitors are required at VCC and VCCL pins of phase ICs.

VOLTAGE LOOP COMPENSATION

The adaptive voltage positioning (AVP) is usually adopted in the computer applications to improve the transient response and reduce the power loss at heavy load. Like current mode control, the adaptive voltage positioning loop introduces extra zero to the voltage loop and splits the double poles of the power stage, which make the voltage loop compensation much easier.

Adaptive voltage positioning lowers the converter voltage by $R_O \cdot I_O$, where R_O is the required output impedance of the converter.

The selection of compensation types depends on the output capacitors used in the converter. For the applications using Electrolytic, Polymer or AL-Polymer capacitors and running at lower frequency, type II compensation shown in Figure 21(a) is usually enough. While for the applications using only ceramic capacitors and running at higher frequency, type III compensation shown in Figure 21(b) is preferred.

For applications where AVP is not required, the compensation is the same as for the regular voltage mode control. For converter using Polymer, AL-Polymer, and ceramic capacitors, which have much higher ESR zero frequency, type III compensation is required as shown in Figure 21(b) with RDRP and CDRP removed.

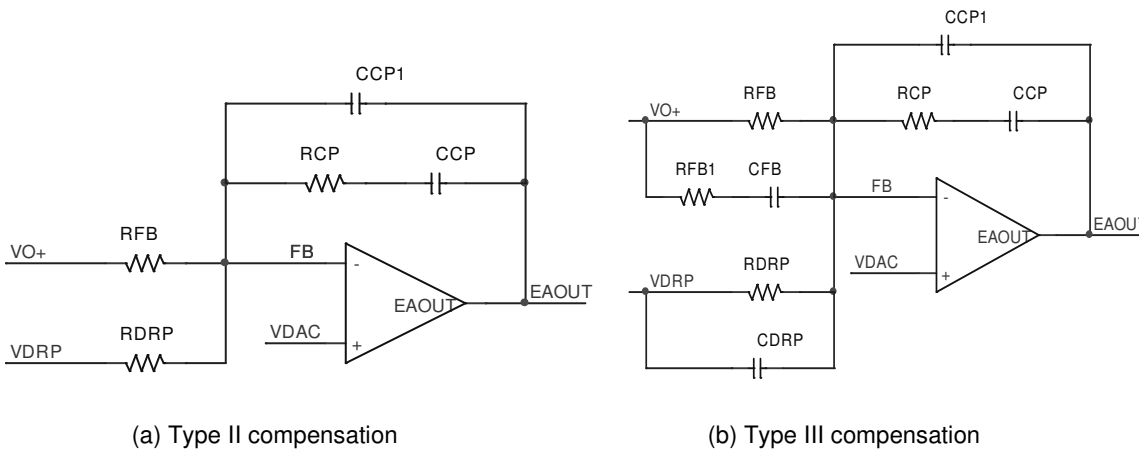

Figure 18. Voltage loop compensation network

Type II Compensation for AVP Applications

Determine the compensation at no load, the worst case condition. Choose the crossover frequency f_c between 1/10 and 1/5 of the switching frequency per phase. Assume the time constant of the resistor and capacitor across the output inductors matches that of the inductor, and determine R_{CP} and C_{CP} from (23) and (24), where L_E and C_E are the equivalent inductance of output inductors and the equivalent capacitance of output capacitors respectively.

$$R_{CP} = \frac{(2\pi * f_c)^2 * L_E * C_E * R_{FB} * 5}{V_I * \sqrt{1 + (2\pi * f_c * C * R_C)^2}} \tag{23}$$

$$C_{CP} = \frac{10 * \sqrt{L_E * C_E}}{R_{CP}} \tag{24}$$

CCP1 is optional and may be needed in some applications to reduce the jitter caused by the high frequency noise. A ceramic capacitor between 10pF and 220pF is usually enough.

Type III Compensation for AVP Applications

Determine the compensation at no load, the worst case condition. Assume the time constant of the resistor and capacitor across the output inductors matches that of the inductor, the crossover frequency and phase margin of the voltage loop can be estimated by (25) and (26), where RLE is the equivalent resistance of inductor DCR.

$$f_{C1} = \frac{R_{DRP}}{2\pi * C_E * G_{CS} * R_{FB} * R_{LE}} \quad (25)$$

$$\theta_{C1} = 90 - A \tan(0.5) * \frac{180}{\pi} \quad (26)$$

Choose the desired crossover frequency f_c around f_{c1} estimated by (25) or choose f_c between 1/10 and 1/5 of the switching frequency per phase, and select the components to ensure the slope of close loop gain is -20dB/Dec around the crossover frequency. Choose resistor RFB1 according to (27), and determine CFB and CDRP from (28) and (29).

$$R_{FB1} = \frac{1}{2} R_{FB} \quad \text{to} \quad R_{FB1} = \frac{2}{3} R_{FB} \quad (27)$$

$$C_{FB} = \frac{1}{4\pi * f_c * R_{FB1}} \quad (28)$$

$$C_{DRP} = \frac{(R_{FB} + R_{FB1}) * C_{FB}}{R_{DRP}} \quad (29)$$

RCP and CCP have limited effect on the crossover frequency, and are used only to fine tune the crossover frequency and transient load response. Determine RCP and CCP from (30) and (31).

$$R_{CP} = \frac{(2\pi * f_c)^2 * L_E * C_E * R_{FB} * 5}{V_I} \quad (30)$$

$$C_{CP} = \frac{10 * \sqrt{L_E * C_E}}{R_{CP}} \quad (31)$$

CCP1 is optional and may be needed in some applications to reduce the jitter caused by the high frequency noise. A ceramic capacitor between 10pF and 220pF is usually enough.

Type III Compensation for Non-AVP Applications

Resistor RDRP and capacitor CDRP are not needed. Choose the crossover frequency f_c between 1/10 and 1/5 of the switching frequency per phase and select the desired phase margin θ_c . Calculate K factor from (32), and determine the component values based on (33) to (37),

$$K = \tan\left[\frac{\pi}{4} * \left(\frac{\theta_c}{180} + 1.5\right)\right] \quad (32)$$

$$R_{CP} = R_{FB} * \frac{(2\pi * \sqrt{L_E * C_E} * f_c)^2 * 5}{V_I * K} \quad (33)$$

$$C_{CP} = \frac{K}{2\pi * f_c * R_{CP}} \quad (34)$$

$$C_{CP1} = \frac{1}{2\pi * f_c * K * R_{CP}} \quad (35)$$

$$C_{FB} = \frac{K}{2\pi * f_C * R_{FB}} \quad (36)$$

$$R_{FB1} = \frac{1}{2\pi * f_C * K * C_{FB}} \quad (37)$$

CURRENT SHARE LOOP COMPENSATION

The internal compensation of current share loop ensures that crossover frequency of the current share loop is at least one decade lower than that of the voltage loop so that the interaction between the two loops is eliminated.

DESIGN EXAMPLE – AMD FIVE + ONE PHASE DUAL OUTPUT CONVERTER (FIGURE 17)

SPECIFICATIONS

Input Voltage: $V_I=12\text{ V}$
 DAC Voltage: $V_{DAC}=1.2\text{ V}$
 No Load Output Voltage Offset for output1: $V_{O_NLOFST}=15\text{ mV}$
 Output1 Current: $I_{O1}=95\text{ ADC}$
 Output2 Current: $I_{O1}=20\text{ ADC}$
 Output1 Over Current Limit: $I_{limit1}=115\text{ ADC}$
 Output2 Over Current Limit: $I_{limit2}= 25\text{ ADC}$
 Output Impedance: $R_{O1}=0.3\text{ m}\Omega$
 Dynamic VID Slew Rate: $SR=3.25\text{mV/uS}$
 Over Temperature Threshold: $T_{MAX}=110\text{ }^\circ\text{C}$

POWER STAGE

Phase Number: $n1=5, n2=1$
 Switching Frequency: $f_{sw}=520\text{ kHz}$
 Output Inductors: $L1=120\text{ nH}, L2=220\text{ nH}, R_{L1}= 0.52\text{m}\Omega, R_{L2}= 0.47\text{m}\Omega$
 Output Capacitors: POSCAPs, $C=470\text{uF}, R_C= 8\text{m}\Omega, \text{Number } C_{n1}=9, C_{n2}=5$

IR3500 EXTERNAL COMPONENTS

Oscillator Resistor R_{ROSC}

Once the switching frequency is chosen, R_{ROSC} can be determined from Figure 2. For switching frequency of 520kHz per phase, choose $R_{OSC}=23.2\text{k}\Omega$.

Soft Start Capacitor $C_{SS/DEL}$

Determine the soft start capacitor from the required soft start time.

$$C_{SS/DEL} = \frac{TD2 * I_{CHG}}{V_{boot}} = \frac{2 * 10^{-3} * 50 * 10^{-6}}{1.0} = 0.1\mu F$$

The soft start delay time is

$$TD1 = \frac{C_{SS/DEL} * 1.1}{I_{CHG}} = \frac{0.1 * 10^{-6} * 1.1}{50 * 10^{-6}} = 2.2\text{mS}$$

The VR ready delay time is

$$TD3 = \frac{C_{SS/DEL} * (3.92 - V_{boot} - 1.1)}{I_{CHG}} = \frac{0.1 * 10^{-6} * (3.92 - 1 - 1.1)}{50 * 10^{-6}} = 3.6\text{mS}$$

The maximum over current fault latch delay time is

$$t_{OCDEL} = 2.5 * \frac{C_{SS/DEL} * 0.13}{I_{DISCHG}} = 2.5 * \frac{0.1 * 10^{-6} * 0.13}{47 * 10^{-6}} = 0.691\text{mS}$$

VDAC Slew Rate Programming Capacitor C_{VDAC} and Resistor R_{VDAC}

$$C_{VDAC} = \frac{I_{SINK}}{SR_{DOWN}} = \frac{45.2 * 10^{-6}}{3.2 * 10^3} = 14.1nF, \text{ Choose } C_{VDAC}=22nF$$

$$R_{VDAC} = 0.5 + \frac{3.2 * 10^{-15}}{C_{VDAC}^2} = 7.1\Omega$$

Over Current Setting Resistor R_{OCSET}

The output1 over current limit is 115A and the output2 over current limit is 25A. From the electrical characteristics table can get the bias current of OCSET pin (IOCSET) is 26uA with ROSC=23.2 kΩ. The total current sense amplifier input offset voltage is around 0mV, Calculate constant K_P , the ratio of inductor peak current over average current in each phase,

$$K_{p1} = \frac{(V_I - V_O) * V_O / (L * V_I * f_{SW} * 2)}{I_{LIMIT} / n} = \frac{(12 - 1.2) * 1.2 / (120 * 10^{-9} * 12 * 520 * 10^3 * 2)}{115 / 5} = 0.38$$

$$K_{p2} = \frac{(12 - 1.2) * 1.2 / (220 * 10^{-9} * 12 * 520 * 10^3 * 2)}{25} = 0.19$$

$$R_{OCSET1} = \left[\frac{I_{LIMIT}}{n} * R_L * (1 + K_P) + V_{CS_TOFST} \right] * G_{CS} / I_{OCSET}$$

$$= \left(\frac{115}{5} * 0.52 * 10^{-3} * 1.38 \right) * 34 / (26 * 10^{-6}) = 21.6k\Omega$$

$$R_{OCSET2} = \left[\frac{I_{LIMIT}}{n} * R_L * (1 + K_P) + V_{CS_TOFST} \right] * G_{CS} / I_{OCSET}$$

$$= \left(\frac{25}{1} * 0.47 * 10^{-3} * 1.19 \right) * 34 / (26 * 10^{-6}) = 18.4k\Omega$$

VCCL Programming Resistor $R_{VCCLFB1}$ and $R_{VCCLFB2}$

Choose VCCL=7V to maximize the converter efficiency. Pre-select $R_{VCCLFB1}=20k\Omega$, and calculate $R_{VCCLFB2}$.

$$R_{VCCLFB2} = \frac{R_{VCCLFB1} * 1.23}{VCCL - 1.23} = \frac{20 * 10^3 * 1.23}{7 - 1.23} = 4.26k\Omega$$

No Load Offset Setting Resistor R_{FB11} , R_{FB13} , R_{THERM1} and Adaptive Voltage Positioning Resistor R_{DRP11} for Output1

Define R_{FB_R} is the effective offset resistor at room temperature equals to $R_{FB11} / (R_{FB13} + R_{THERM1})$. Given the offset voltage V_{O_NLOFST} above the DAC voltage, calculate the sink current from the FB1 pin $I_{FB1} = 26\mu A$ using the equation in the ELECTRICAL CHARACTERISTICS Table, then the effective offset resistor value R_{FB_R1} can be determined by:

$$R_{FB_R1} = \frac{V_{O_NLOFST}}{I_{FB1}} = \frac{15 * 10^{-3}}{26 * 10^{-6}} = 577\Omega$$

Adaptive voltage positioning lowers the converter voltage by $R_O * I_O$, where R_O is the required output impedance of the converter. Pre-select feedback resistor R_{FB} , and calculate the droop resistor R_{DRP} ,

$$R_{DRP1} = \frac{R_{FB_R} * R_{L_ROOM} * G_{CS}}{n * R_O} = \frac{577 * 0.52 * 10^{-3} * 34}{5 * 0.3 * 10^{-3}} = 6.7 K\Omega$$

In the case of thermal compensation is required, use equation (14) to (17) to select the RFB network resistors.

IR3505 EXTERNAL COMPONENTS

Inductor Current Sensing Capacitor C_{CS} and Resistor R_{CS}

Choose $C_{CS1}=C_{CS2}=0.1\mu F$, and calculate R_{CS} ,

$$R_{CS1} = \frac{L/R_L}{C_{CS}} = \frac{120 * 10^{-9} / (0.52 * 10^{-3})}{0.1 * 10^{-6}} = 2.3 k\Omega$$

$$R_{CS2} = \frac{L/R_L}{C_{CS}} = \frac{220 * 10^{-9} / (0.47 * 10^{-3})}{0.1 * 10^{-6}} = 4.7 k\Omega$$

LAYOUT GUIDELINES

The following layout guidelines are recommended to reduce the parasitic inductance and resistance of the PCB layout, therefore minimizing the noise coupled to the IC.

- Dedicate at least one middle layer for a ground plane LGND.
- Connect the ground tab under the control IC to LGND plane through a via.
- Separate analog bus (EAIN, DACIN and ISHARE) from digital bus (CLKIN, PHSIN, and PHSOUT) to reduce the noise coupling.
- Place VCCL decoupling capacitor VCCL as close as possible to VCCL and LGND pins.
- Place the following critical components on the same layer as control IC and position them as close as possible to the respective pins, ROOSC, ROCSET, RVDAC, CVDAC, and CSS/DEL. Avoid using any via for the connection.
- Place the compensation components on the same layer as control IC and position them as close as possible to EAOUT, FB, VO and VDRP pins. Avoid using any via for the connection.
- Use Kelvin connections for the remote voltage sense signals, VOSNS+ and VOSNS-, and avoid crossing over the fast transition nodes, i.e. switching nodes, gate drive signals and bootstrap nodes.
- Avoid analog control bus signals, VDAC, IIN, and especially EAOUT, crossing over the fast transition nodes.
- Separate digital bus, CLKOUT, PHSOUT and PHSIN from the analog control bus and other compensation components.

PCB METAL AND COMPONENT PLACEMENT

- Lead land width should be equal to nominal part lead width. The minimum lead to lead spacing should be $\geq 0.2\text{mm}$ to prevent shorting.
- Lead land length should be equal to maximum part lead length + 0.3 mm outboard extension + 0.05mm inboard extension. The outboard extension ensures a large and inspectable toe fillet, and the inboard extension will accommodate any part misalignment and ensure a fillet.
- Center pad land length and width should be equal to maximum part pad length and width. However, the minimum metal to metal spacing should be $\geq 0.17\text{mm}$ for 2 oz. Copper ($\geq 0.1\text{mm}$ for 1 oz. Copper and $\geq 0.23\text{mm}$ for 3 oz. Copper)
- A single 0.30mm diameter via shall be placed in the center of the pad land and connected to ground to minimize the noise effect on the IC.
- No pcb traces should be routed nor vias placed under any of the 4 corners of the IC package. Doing so can cause the IC to rise up from the pcb resulting in poor solder joints to the IC leads.

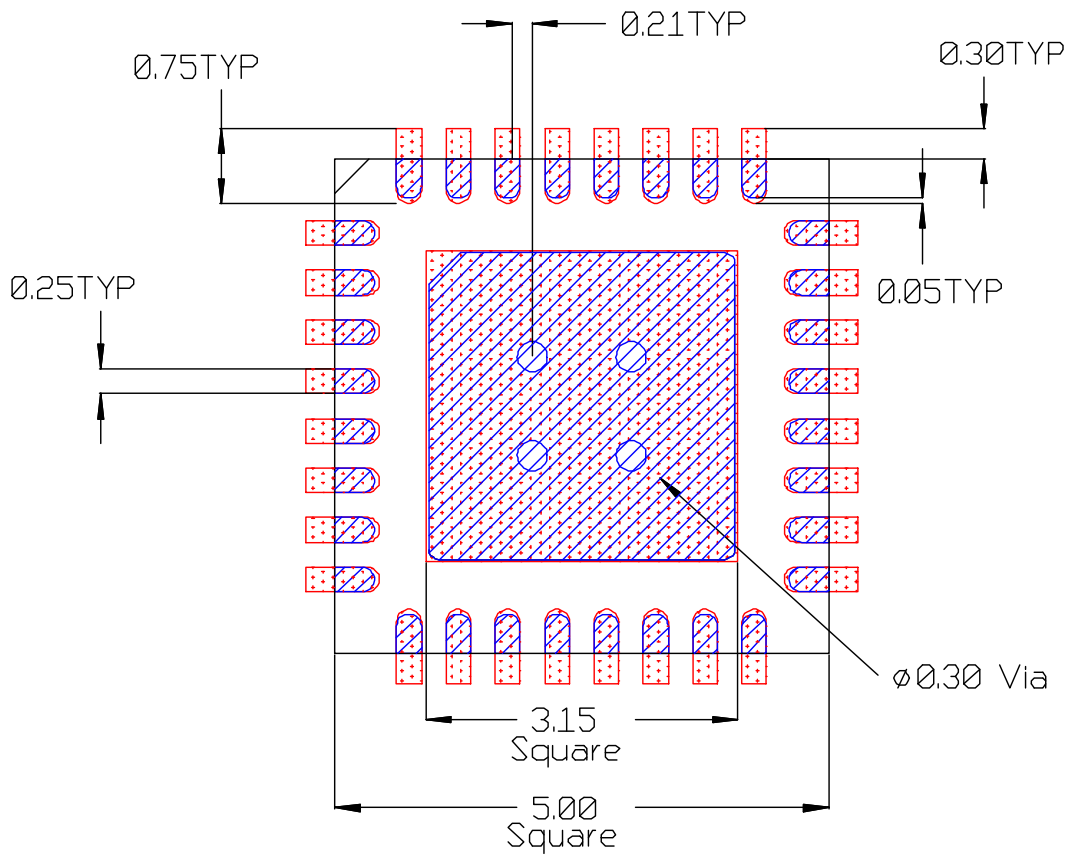

All Dimensions in mm

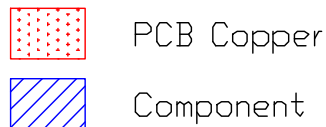

SOLDER RESIST

- The solder resist should be pulled away from the metal lead lands by a minimum of 0.06mm. The solder resist mis-alignment is a maximum of 0.05mm and it is recommended that the lead lands are all Non Solder Mask Defined (NSMD). Therefore pulling the S/R 0.06mm will always ensure NSMD pads.
- The minimum solder resist width is 0.13mm.
- At the inside corner of the solder resist where the lead land groups meet, it is recommended to provide a fillet so a solder resist width of $\geq 0.17\text{mm}$ remains.
- The land pad should be Solder Mask Defined (SMD), with a minimum overlap of the solder resist onto the copper of 0.06mm to accommodate solder resist mis-alignment. In 0.5mm pitch cases it is allowable to have the solder resist opening for the land pad to be smaller than the part pad.
- Ensure that the solder resist in-between the lead lands and the pad land is $\geq 0.15\text{mm}$ due to the high aspect ratio of the solder resist strip separating the lead lands from the pad land.
- The single via in the land pad should be tented or plugged from bottom boardside with solder resist.

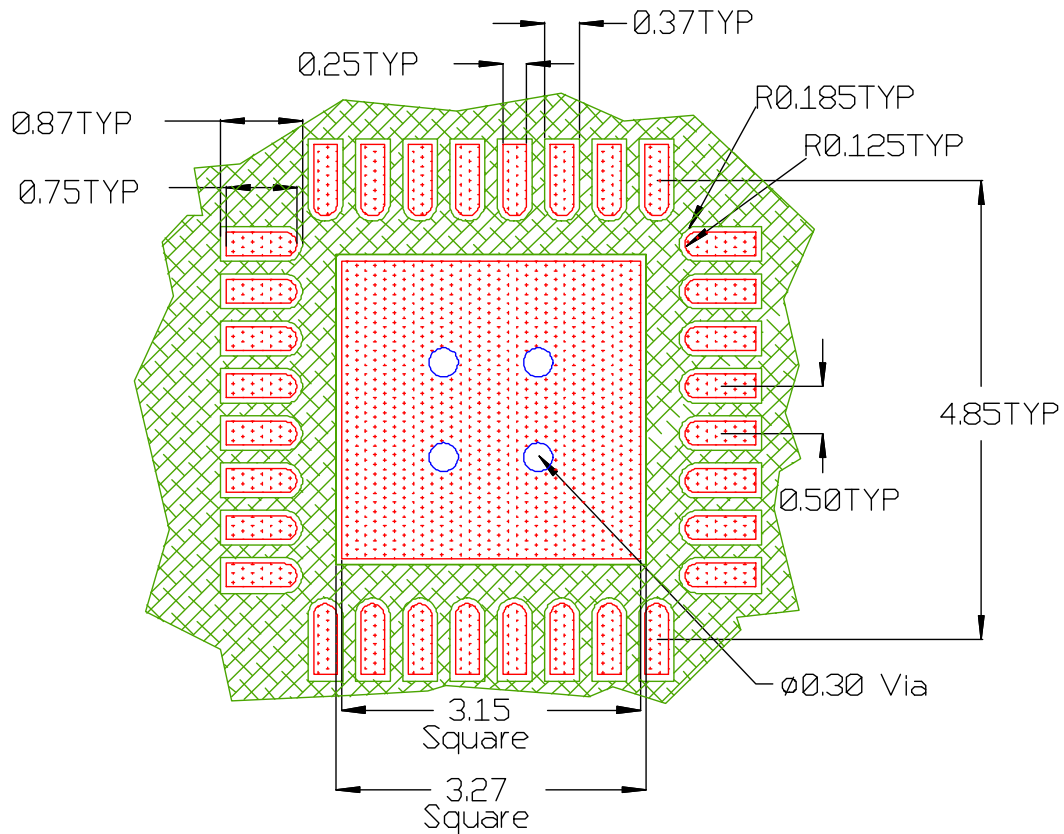

All Dimensions in mm

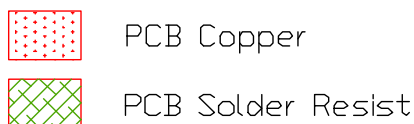

STENCIL DESIGN

- The stencil apertures for the lead lands should be approximately 80% of the area of the lead lands. Reducing the amount of solder deposited will minimize the occurrence of lead shorts. Since for 0.5mm pitch devices the leads are only 0.25mm wide, the stencil apertures should not be made narrower; openings in stencils < 0.25mm wide are difficult to maintain repeatable solder release.
- The stencil lead land apertures should therefore be shortened in length by 80% and centered on the lead land.
- The land pad aperture should be striped with 0.25mm wide openings and spaces to deposit approximately 50% area of solder on the center pad. If too much solder is deposited on the center pad the part will float and the lead lands will be open.
- The maximum length and width of the land pad stencil aperture should be equal to the solder resist opening minus an annular 0.2mm pull back to decrease the incidence of shorting the center land to the lead lands when the part is pushed into the solder paste.

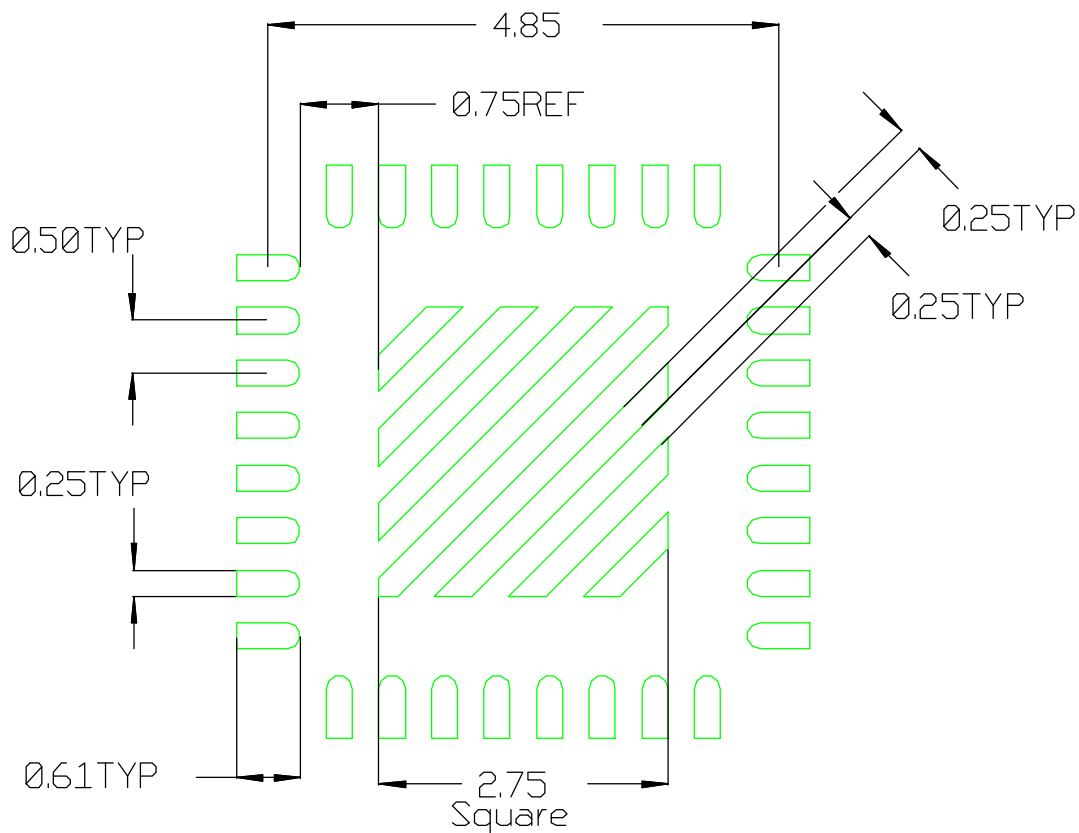

Stencil Aperture
 All Dimensions in mm

PACKAGE INFORMATION

32L MLPQ (5 x 5 mm Body) $\theta_{JA}=24.4\text{ }^{\circ}\text{C/W}$, $\theta_{JC}=0.86\text{ }^{\circ}\text{C/W}$

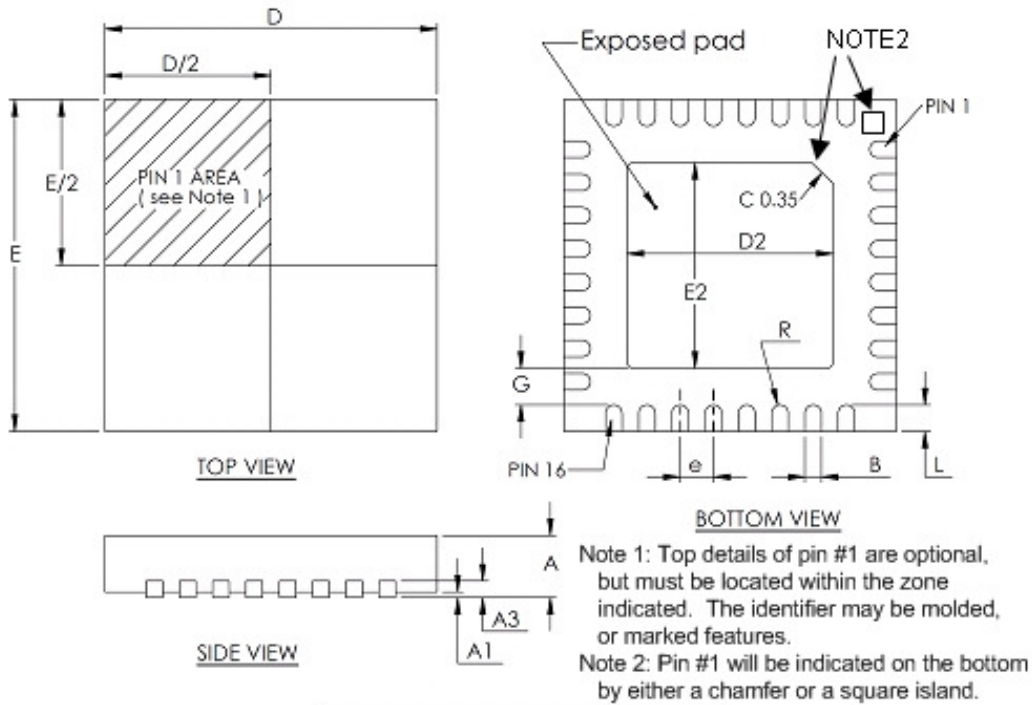

32-PIN 5x5 (unit: MM)			
DIM	MIN	NOM	MAX
A	0.8	0.85	0.9
A1	0.00		0.05
A3	0.20 REF		
B	0.20	0.25	0.30
D	4.95	5.00	5.05
D2	3.00	3.10	3.20
E	4.95	5.00	5.05
E2	3.00	3.10	3.20
e	0.5 REF		
G	0.55 REF		
L	0.30	0.40	0.50
R	0.125 TYP		

Data and specifications subject to change without notice.
 This product has been designed and qualified for the Consumer market.
 Qualification Standards can be found on IR's Web site.

Looking for pricing, stock, or lifecycle information?

Click below to explore more details on WIN SOURCE:

 [View IR3504MTRPBF on WIN SOURCE](#)

 [Infineon Technologies](#) Information

Optimize Your Supply Chain with WIN SOURCE Solutions

-  Global Sourcing Solution
-  Obsolete Management
-  Cost Control Management
-  Shortage Management
-  Alternative Solution
-  Excess Inventory Management