

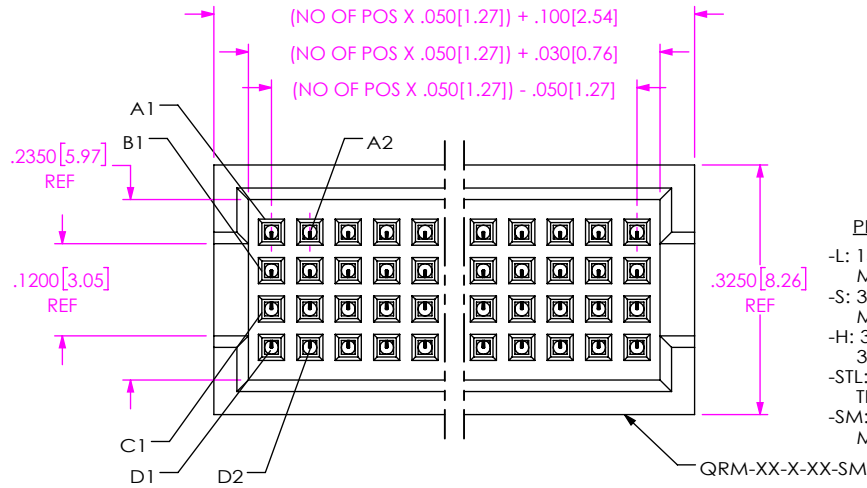

**THE DATASHEET OF
MOLC-132-02-STL-Q-LC-P**



DO NOT SCALE FROM THIS PRINT



MOLC-1XX-02-XXX-Q-XX-X-XX

NO OF POSITIONS
-05 THRU -50

LEAD STYLE
-02: SURFACE MOUNT

PLATING SPECIFICATION
-L: 15μ" LIGHT SELECTIVE GOLD IN CONTACT AREA, MATTE TIN ON TAIL
-S: 30μ" SELECTIVE GOLD IN CONTACT AREA, MATTE TIN ON TAIL
-H: 30μ" HEAVY GOLD IN CONTACT AREA, 3μ" GOLD ON TAIL
-STL: 30μ" SELECTIVE GOLD IN CONTACT AREA, TIN/LEAD (90/10 +/-5%) ON TAIL
-SM: 15μ" LIGHT GOLD IN CONTACT AREA, MATTE TIN ON TAIL

PACKAGING
BLANK: TUBES (SEE NOTES 3 & 7)
-TR: TAPE & REEL (SEE NOTES 7 & 8)
-FR: FULL REEL QTY TAPE & REEL (SEE NOTES 7 & 8)

PICK & PLACE OPTION
-P: PICK AND PLACE PAD (USE PPP-19)

OPTION
-LC: LOCKING CLIP (USE LC-09-TM) (SEE NOTE 6)

BODY SPECIFICATION
-Q: 4 ROW (USE QRM-XX-Q-01-SM)

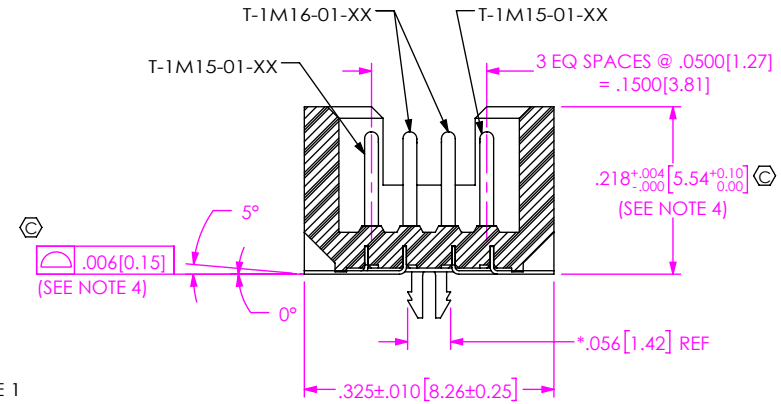
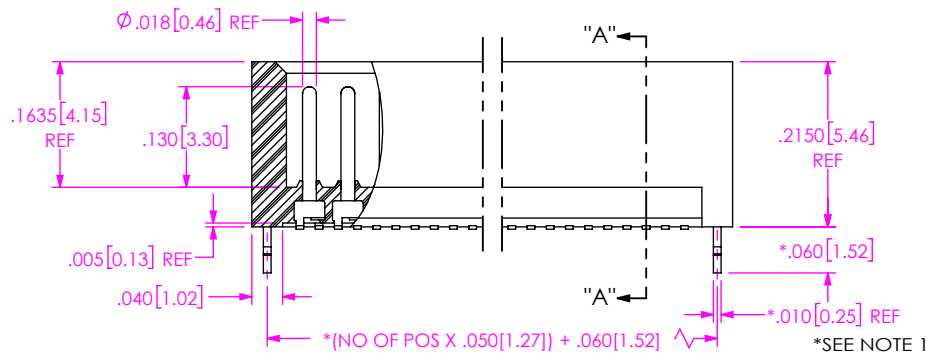

SECTION "A"-"A"

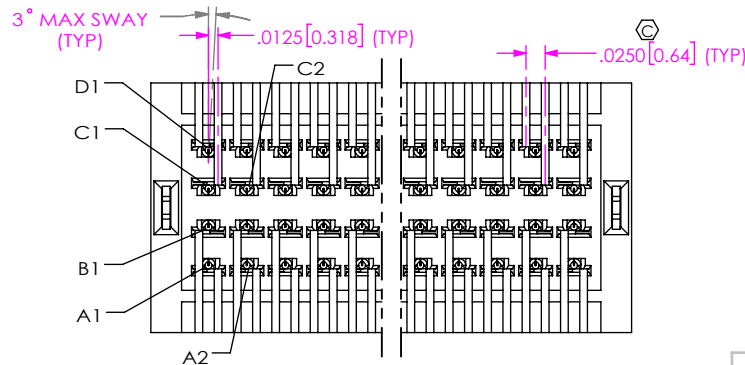

NOTES:

1. DIMENSIONS PERTAIN TO -LC OPTION ONLY.
2. INSULATOR MATERIAL: VECTRA E130
3. TUBES ARE STANDARD PACKAGING.
4. DIMENSION TO BE MEASURED AT BEND OF THE LEAD, AND LEADS MUST REST ON PLASTIC RIBS.
5. Ⓢ REPRESENTS A CRITICAL DIMENSION
6. DUE TO THE HIGH AMOUNT OF INSERTION FORCE NEEDED, THE -LC OPTION IS NOT COMPATIBLE WITH AUTO PLACEMENT. SAMTEC RECOMMENDS MANUAL PLACEMENT FOR ALL ASSEMBLIES WITH THE -LC OPTION.
7. ORDERS WILL BE PACKAGED ACCORDING TO THE SAMTEC PACKAGING EFFICIENCY STANDARDS (SPES) FOUND ON WWW.SAMTEC.COM.
8. ATTACH LABEL TO EACH REEL.

UNLESS OTHERWISE SPECIFIED, DIMENSIONS ARE IN INCHES.
TOLERANCES ARE:
DECIMALS ANGLES
.XX: ±.01[.3] 5°
.XXX: ±.005[.13]
.XXXX: ±.0020[.051]

PROPRIETARY NOTE
THIS DOCUMENT CONTAINS CONFIDENTIAL AND PROPRIETARY INFORMATION AND ALL DESIGN, MANUFACTURING, REPRODUCTION, USE, PATENT RIGHTS AND SALES RIGHTS ARE EXPRESSLY RESERVED BY SAMTEC, INC. THIS DOCUMENT SHALL NOT BE DISCLOSED, IN WHOLE OR PART, TO ANY UNAUTHORIZED PERSON OR ENTITY NOR REPRODUCED, TRANSFERRED OR INCORPORATED IN ANY OTHER PROJECT IN ANY MANNER WITHOUT THE EXPRESS WRITTEN CONSENT OF SAMTEC, INC.



520 PARK EAST BLVD. NEW ALBANY, IN 47150
PHONE: 812-944-6733 FAX: 812-948-5047
e-Mail info@SAMTEC.com code 55322

MATERIAL: DO NOT SCALE DRAWING SHEET SCALE: 4:1
INSULATOR: VECTRA E130, LCP, UL 94 V0
COLOR: BLACK
TERMINAL: PHOSPHOR BRONZE

DESCRIPTION: SURFACE MOUNT .050 X .050 4 ROW SHROUDED TERMINAL STRIP
DWG. NO. MOLC-1XX-02-XXX-Q-XX-X-XX
BY: GREG R 3/29/1993 SHEET 1 OF 2

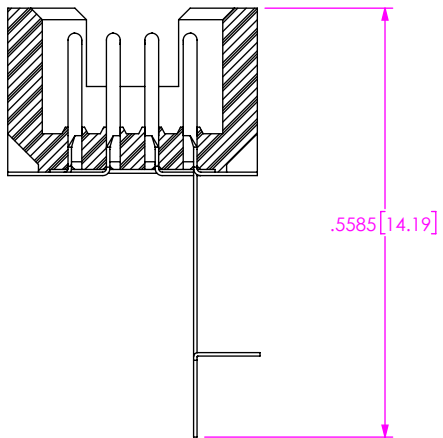

IN-PROCESS

$$\frac{((\text{NO OF POS} \times .050[1.27] + .100[2.54])/2 - .135[3.43]) \pm .020[0.51]}$$

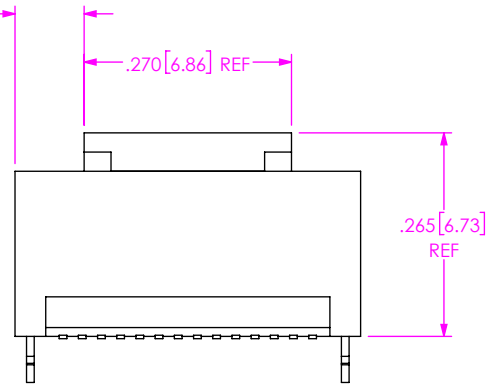

-P: PICK AND PLACE PAD

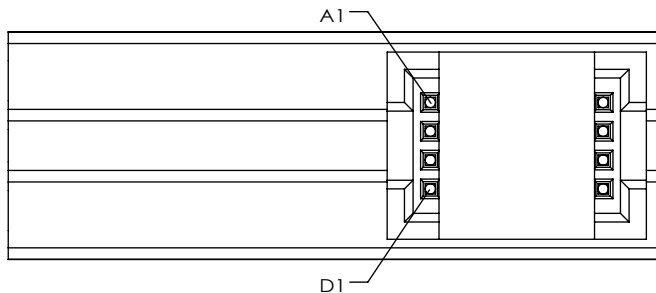
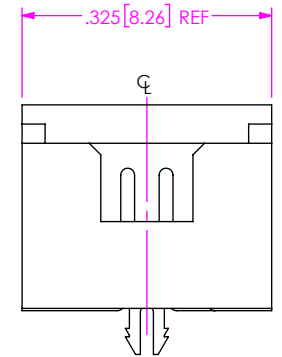
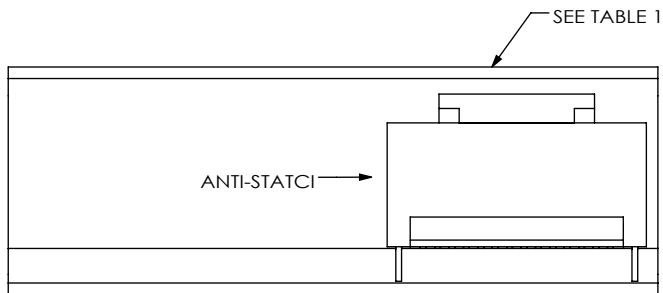
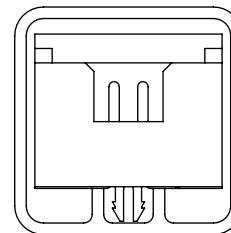

TABLE 1		
OPTION	TUBE	PLUG
BLANK, -LC	PT-1-24-04-38	TP-03
-P	PT-1-24-03-38	TP-03



PACKAGE PARTS IN TUBE AS SHOWN



PROPRIETARY NOTE
 THIS DOCUMENT CONTAINS CONFIDENTIAL AND PROPRIETARY INFORMATION AND ALL DESIGN, MANUFACTURING, REPRODUCTION, USE, PATENT RIGHTS AND SALES RIGHTS ARE EXPRESSLY RESERVED BY SAMTEC, INC. THIS DOCUMENT SHALL NOT BE DISCLOSED, IN WHOLE OR PART, TO ANY UNAUTHORIZED PERSON OR ENTITY NOR REPRODUCED, TRANSFERRED OR INCORPORATED IN ANY OTHER PROJECT IN ANY MANNER WITHOUT THE EXPRESS WRITTEN CONSENT OF SAMTEC, INC.

DO NOT SCALE DRAWING

SHEET SCALE: 4:1



520 PARK EAST BLVD, NEW ALBANY, IN 47150
 PHONE: 812-944-6733 FAX: 812-948-5047
 e-Mail: info@SAMTEC.com code 55322



DESCRIPTION: SURFACE MOUNT .050 X .050 4 ROW SHROUDED TERMINAL STRIP

DWG. NO. MOLC-1XX-02-XXX-Q-XX-X-XX

BY: GREG R 3/29/1993 SHEET 2 OF 2

Looking for pricing, stock, or lifecycle information?

Click below to explore more details on WIN SOURCE:

-  [View MOLC-132-02-STL-Q-LC-P on WIN SOURCE](#)
-  [Samtec Inc. Information](#)

Optimize Your Supply Chain with WIN SOURCE Solutions

-  Global Sourcing Solution
-  Obsolete Management
-  Cost Control Management
-  Shortage Management
-  Alternative Solution
-  Excess Inventory Management