



# THE DATASHEET OF CD4011



## CMOS Decade Up-Down Counter/Latch/Display Driver

High-Voltage Type (20-V Rating)

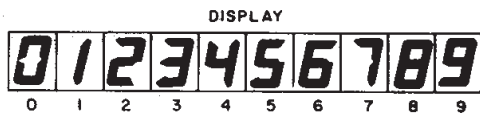

92CS-31380

**Features:**

- Separate clock-up and clock-down lines-
- Capable of driving common cathode LEDs and other displays directly
- Allows cascading without any external circuitry
- 100% tested for quiescent current at 20 V
- Maximum input current of 1  $\mu$ A at 18 V over full package-temperature range; 100 nA at 18 V and 25° C

■ CD40110B is a dual-clocked up/down counter with a special preconditioning circuit that allows the counter to be clocked, via positive going inputs, up or down regardless of the state or timing (within 100 ns typ.) of the other clock line.

The clock signal is fed into the control logic and Johnson counter after it is preconditioned. The outputs of the Johnson counter (which include anti-lock gating to avoid being locked at an illegal state) are fed into a latch. This data can be fed directly to the decoder through the latch or can be strobed to hold a particular count while the Johnson counter continues to be clocked. The decoder feeds a seven-segment bipolar output driver which can source up to 25 mA to drive LEDs and other displays such as low-voltage fluorescent and incandescent lamps.

A short duration negative-going pulse appears on the BORROW output when the count changes from 0 to 9 or the CARRY output when the count changes from 9 to 0. At the other times the BORROW and CARRY outputs are a logic 1.

The CARRY and BORROW outputs can be tied directly to the clock-up and clock-down lines respectively of another CD40110B for easy cascading of several counters.

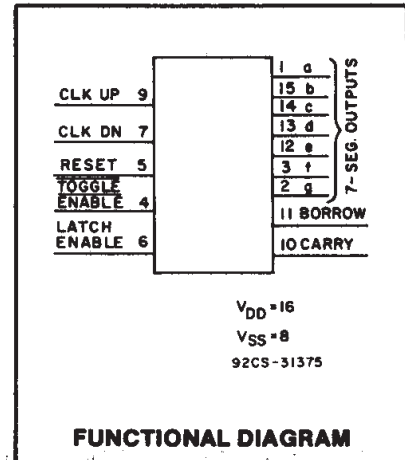

**FUNCTIONAL DIAGRAM**

- Noise margin (full package-temperature range) =
  - 1 V at  $V_{DD} = 5$  V
  - 2 V at  $V_{DD} = 10$  V
  - 2.5 V at  $V_{DD} = 15$  V
- 5 V, 10 V and 15 V parametric ratings
- Meets all requirements of JEDEC Tentative Standard No. 13B, "Standard Specifications for Description of 'B' Series CMOS Devices".

**Applications:**

- Rate comparators
- General counting applications where display is desired
- Up-down counting applications where input pulses are random in nature

The CD40110B types are supplied in 16-lead dual-in-line ceramic packages (D and F suffixes), and 16-lead dual-in-line plastic package (E suffix), and also available in chip form, (H suffix).

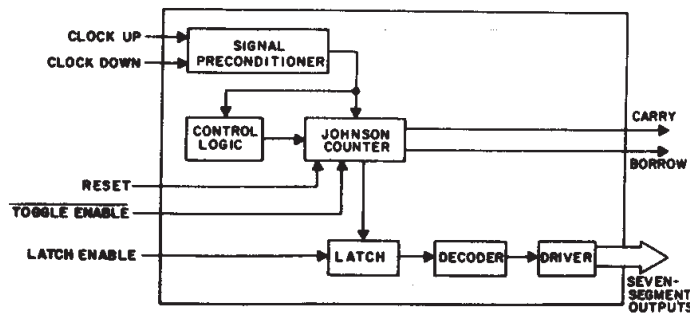

92CS-29200RI

Fig. 1 - Functional diagram.

3  
COMMERCIAL CMOS  
HIGH VOLTAGE ICs

## CD40110B Types

### MAXIMUM RATINGS, Absolute-Maximum Values:

DC SUPPLY-VOLTAGE RANGE, (V <sub>DD</sub> )	-0.5V to +20V
Voltages referenced to V <sub>SS</sub> Terminal	
INPUT VOLTAGE RANGE, ALL INPUTS	-0.5V to V <sub>DD</sub> +0.5V
DC INPUT CURRENT, ANY ONE INPUT	±10mA
POWER DISSIPATION PER PACKAGE (P <sub>D</sub> ):	
For T <sub>A</sub> = -55°C to +100°C	500mW
For T <sub>A</sub> = +100°C to +125°C	Derate Linearly at 12mW/°C to 200mW
DEVICE DISSIPATION PER OUTPUT TRANSISTOR	
FOR T <sub>A</sub> = FULL PACKAGE-TEMPERATURE RANGE (All Package Types)	100mW
OPERATING-TEMPERATURE RANGE (T <sub>A</sub> )	-55°C to +125°C
STORAGE TEMPERATURE RANGE (T <sub>stg</sub> )	-65°C to +150°C
LEAD TEMPERATURE (DURING SOLDERING):	
At distance 1/16 ± 1/32 inch (1.59 ± 0.79mm) from case for 10s max	+265°C

### RECOMMENDED OPERATING CONDITIONS

For maximum reliability, nominal operating conditions should be selected so that operation is always within the following ranges:

CHARACTERISTIC	V <sub>DD</sub> V	LIMITS		UNITS
		MIN.	MAX.	
Supply-Voltage Range (For T <sub>A</sub> = Full Package Temperature Range)	—	3	18	V
Clock Input Frequency (Sum of CL <sub>UP</sub> & CL <sub>DN</sub> Freqs.)	5	—	1	MHz
	10	—	3	
	15	—	5	
Clock Pulse Width	5	110	—	ns
	10	40	—	
	15	30	—	
Latch Enable Pulse Width	5	110	—	
	10	30	—	
	15	24	—	
Reset Removal-Time	5	550	—	
	10	200	—	
	15	130	—	
Reset Pulse Width	5	350	—	
	10	170	—	
	15	120	—	

## CD40110B Types

### STATIC ELECTRICAL CHARACTERISTICS

Characteristic	Conditions				LIMITS AT INDICATED TEMPERATURES (°C)							Units
	I <sub>OH</sub> (mA)	V <sub>OH</sub> (V)	V <sub>IN</sub> (V)	V <sub>DD</sub> (V)	-55	-40	+85	+125	+25			
									Min.	Typ.	Max.	
Quiescent Device Current Max. I <sub>DD</sub>	—	—	—	5	5	5	150	150	—	0.04	5	μA
	—	—	—	10	10	10	300	300	—	0.04	10	
	—	—	—	15	20	20	600	600	—	0.04	20	
	—	—	—	20	100	100	3000	3000	—	0.08	100	
Output Voltage Low-Level Max. V <sub>OL</sub>	—	—	0,5	5	0,05				—	0	0,05	V
	—	—	0,10	10	0,05				—	0	0,05	
	—	—	0,15	15	0,05				—	0	0,05	
High-Level Min. V <sub>OH</sub>	—	—	0,5	5	—	—	—	—	—	4,55	—	V
	—	—	0,10	10	—	—	—	—	—	9,55	—	
	—	—	0,15	15	—	—	—	—	—	14,55	—	
Input Low Voltage Max. V <sub>IL</sub>	—	0,5, 3,8	—	5	1,5				—	—	1,5	V
	—	1, 8,8	—	10	3				—	—	3	
	—	1,5, 13,8	—	15	4				—	—	4	
Input High Voltage Min. V <sub>IH</sub>	—	0,5, 3,8	—	5	3,8				3,5	—	—	V
	—	1, 8,8	—	10	7				7	—	—	
	—	1,5, 13,8	—	15	11				11	—	—	
7-Segment Outputs Output Drive Voltage, High Min. V <sub>OH</sub>	■	—	—	5	3,9		4		3,9	4,5	—	V
	-5	—	—		3,65		3,7		3,7	4,3	—	
	-10	—	—		3,55		3,65		3,65	4,25	—	
	-15	—	—		3,5		3,5		3,6	4,15	—	
	-20	—	—		3,45		3,35		3,45	4	—	
	■	—	—	10	8,75		8,85		8,75	9,5	—	
	-5	—	—		8,45		8,55		8,55	9,3	—	
	-10	—	—		8,42		8,5		8,5	9,25	—	
	-15	—	—		8,4		8,47		8,47	9,2	—	
	-20	—	—		8,4		8,40		8,45	9,1	—	
	■	—	—	15	13,8		13,9		13,8	14,5	—	
	-5	—	—		13,65		13,75		13,75	14,35	—	
	-10	—	—		13,6		13,72		13,72	14,3	—	
	-15	—	—		13,6		13,7		13,7	14,2	—	
	-20	—	—		13,6		13,6		13,65	14,1	—	
■	—	—	15	13,3		13,25		13,3	14,0	—		
-5	—	—		13,3		13,25		13,3	14,0	—		
-10	—	—		13,3		13,25		13,3	14,0	—		
-15	—	—		13,3		13,25		13,3	14,0	—		
-20	—	—		13,3		13,25		13,3	14,0	—		
7-Segment Outputs Output Low (Sink) Current Min. I <sub>OL</sub>	—	0,4	0,5	5	1,28	1,22	0,84	0,72	1	2	—	mA
	—	0,5	0,10	10	3,2	3	2,2	1,8	2,6	5,2	—	
	—	1,5	0,15	15	8,4	8	5,6	4,8	6,8	13,6	—	
Carry Outputs Output Low (Sink) Current Min. I <sub>OL</sub>	—	0,4	0,5	5	0,64	0,61	0,42	0,36	0,51	1	—	mA
	—	0,5	0,10	10	1,6	1,5	1,1	0,9	1,3	2,6	—	
	—	1,5	0,15	15	4,2	4	2,8	2,4	3,4	6,8	—	
Output High (Source) Current Min. I <sub>OH</sub>	—	4,6	0,5	5	-0,64	-0,61	-0,42	-0,36	-0,51	-1	—	mA
	—	2,5	0,5	5	-2	-1,8	-1,3	-1,15	-1,6	-3,2	—	
	—	9,5	0,10	10	-1,6	-1,5	-1,1	-0,9	-1,3	-2,6	—	
	—	13,5	0,15	15	-4,2	-4	-2,8	-2,4	-3,4	-6,8	—	
Input Current Max. I <sub>IN</sub>	—	0,18	0,18	18	±0,1	±0,1	±1	±1	—	±10 <sup>-5</sup>	±0,1	μA

■ 0(10 μA)

**3**  
 COMMERCIAL CMOS  
 HIGH VOLTAGE ICs

# CD40110B Types

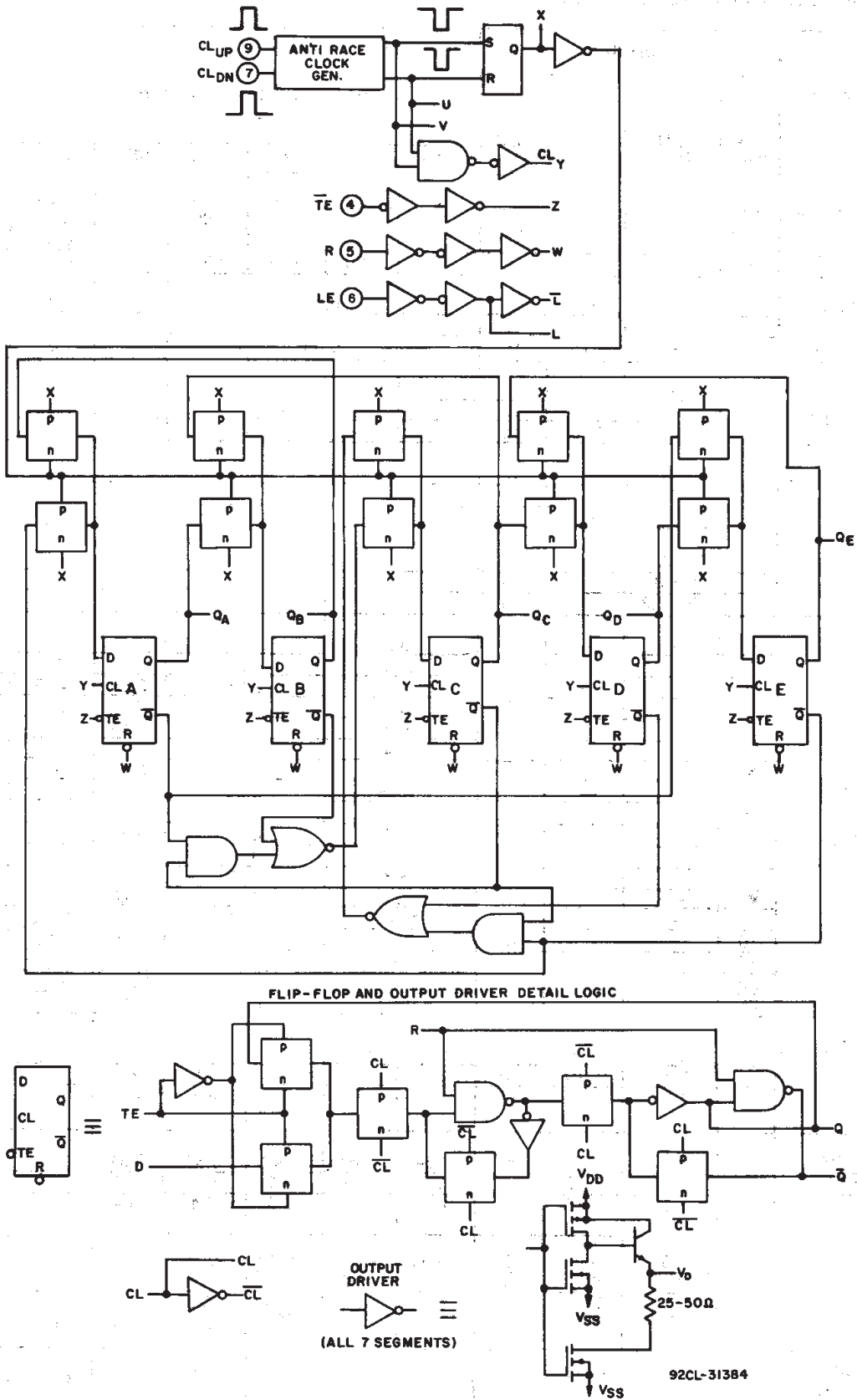
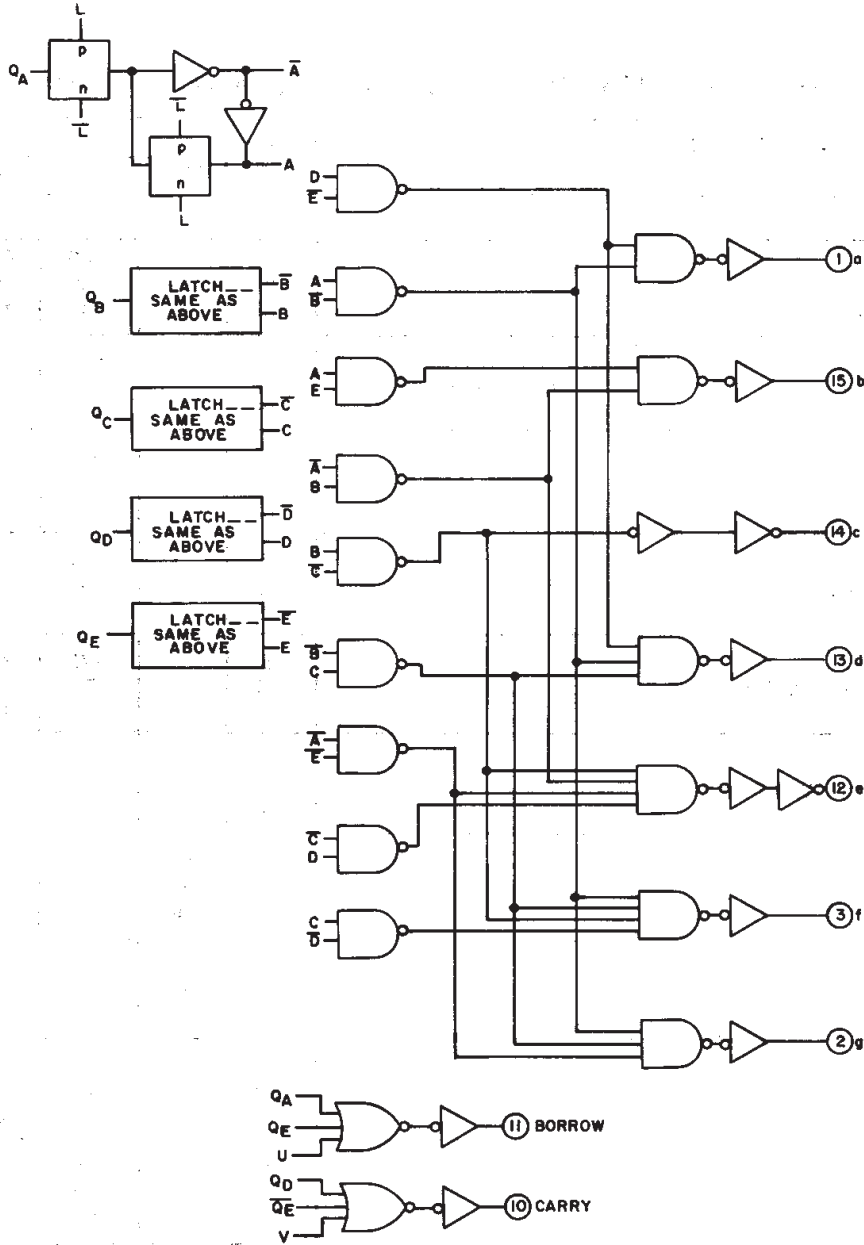

Fig. 2 - Logic diagram with flip-flop and output-driver details.  
(cont'd on page 5)

# CD40110B Types



92CL-31384

Fig. 2 - Logic diagram with flip-flop and output-driver details.

## DISPLAY SEGMENTS

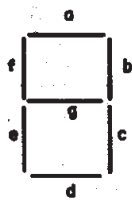

92CS-31376

## TERMINAL ASSIGNMENT

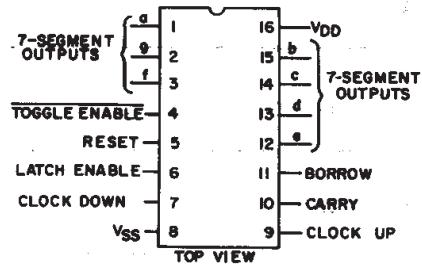

92CS-31377

3  
COMMERCIAL CMOS  
HIGH VOLTAGE ICs

## CD40110B Types

**DYNAMIC ELECTRICAL CHARACTERISTICS at  $T_A = 25^\circ\text{C}$ , Input  $t_r, t_f = 20\text{ ns}$ ,  $C_L = 50\text{ pF}$ ,  $R_L = 200\text{ k}\Omega$**

CHARACTERISTIC	V <sub>DD</sub> (V)	LIMITS			UNITS
		MIN.	TYP.	MAX.	
<b>Clock Up/Clock Down</b>					
Propagation Delay Time: Clock to Carry or Borrow <span style="float: right;"><math>t_{PLH}, t_{PHL}</math></span>	5	—	300	600	ns
	10	—	100	200	
	15	—	70	140	
Clock to Segment <span style="float: right;"><math>t_{PLH}, t_{PHL}</math></span>	5	—	925	1850	
	10	—	360	720	
	15	—	250	500	
Minimum Clock Pulse Width	5	—	55	110	
	10	—	20	40	
	15	—	15	30	
Maximum Clock Input Frequency (Sum of CL <sub>UP</sub> & CL <sub>DN</sub> F) <span style="float: right;"><math>f_{CL}</math></span>	5	1	2.5	—	MHz
	10	3	6	—	
	15	5	8.5	—	
Minimum Toggle Enable Pulse Width	5	—	175	350	ns
	10	—	75	150	
	15	—	55	110	
Minimum Latch Enable Pulse Width	5	—	55	110	
	10	—	15	30	
	15	—	12	24	
Output Pulse Width: Carry	5	115	230	—	
	10	60	120	—	
	15	40	75	—	
Borrow	5	140	275	—	
	10	65	130	—	
	15	45	85	—	
Transition Time: Carry or Borrow <span style="float: right;"><math>t_{TLH}, t_{THL}</math></span>	5	—	85	170	
	10	—	45	90	
	15	—	30	60	
Minimum Delay Time Between CL <sub>UP</sub> & CL <sub>DN</sub>	5	—	100	—	
	10	—	80	—	
	15	—	60	—	
Maximum Clock Rise or Fall Time <span style="float: right;"><math>t_{rCL}, t_{fCL}</math></span>	5	—	—	15	$\mu\text{s}$
	10	—	—	15	
	15	—	—	15	
<b>Reset</b>					
Propagation Delay Time Reset to Output <span style="float: right;"><math>t_{PLH}, t_{PHL}</math></span>	5	—	650	1300	ns
	10	—	350	700	
	15	—	160	320	
Minimum Reset Removal Time	5	—	-275	0	
	10	—	-100	0	
	15	—	-65	0	
Minimum Reset Pulse Width	5	—	175	350	
	10	—	85	170	
	15	—	60	120	

# CD40110B Types

## TRUTH TABLE

CLOCK UP*	CLOCK DOWN*	LATCH ENABLE	TOGGLE ENABLE	RESET	COUNTER	DISPLAY
	X	0	0	0	Increments by 1	Follows Counter
X		0	0	0	Decrements by 1	Follows Counter
		X	X	0	No Change	No Change
X	X	1	X	1	Goes to 00000	Remains Fixed
X	X	0	X	1	Goes to 00000	Follows Counter (Display = $\overline{7}$ )
X	X	X	1	0	Inhibited	Remains Fixed
	X	1	0	0	Increments by 1	Remains Fixed
X		1	0	0	Decrements by 1	Remains Fixed

X = Don't Care      1 = High State      0 = Low State

\* Typically 100 ns between clock-up and clock-down positive transitions are required to ensure proper counting.

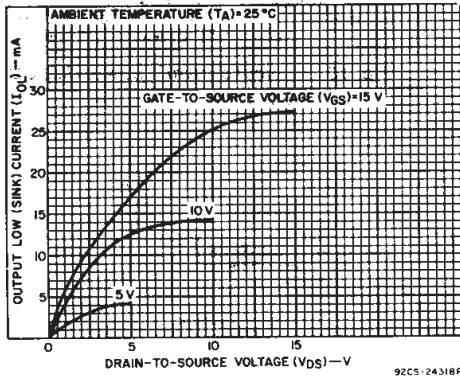

Fig. 3 - Typical carry or borrow output low (sink) current characteristics.

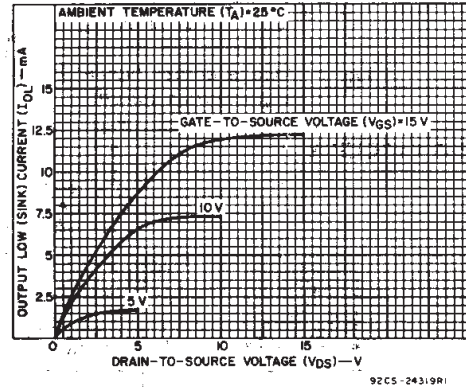

Fig. 4 - Minimum carry or borrow output low (sink) current characteristics.

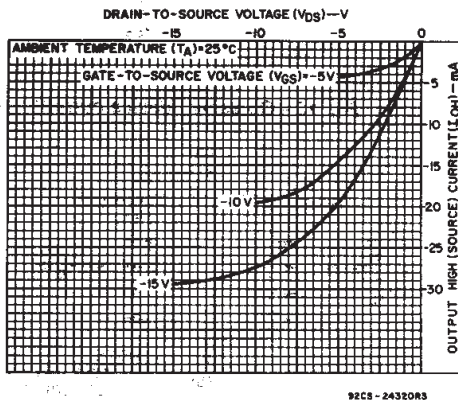

Fig. 5 - Typical carry or borrow output high (source) current characteristics.

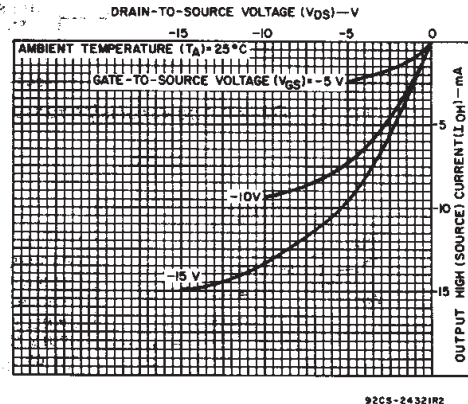

Fig. 6 - Minimum carry or borrow output high (source) current characteristics.

# CD40110B Types

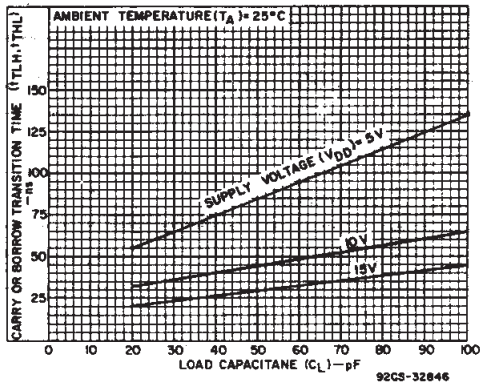

Fig. 7 - Typical carry or borrow transition time vs. load capacitance.

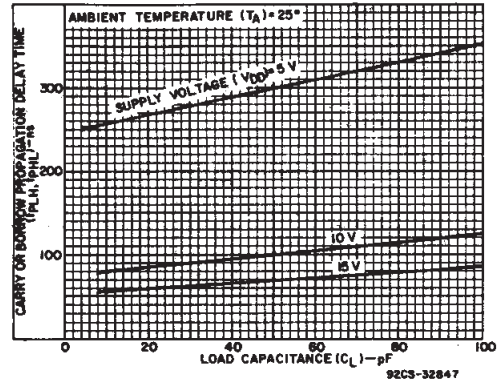

Fig. 8 - Typical carry or borrow propagation delay time vs. load capacitance.

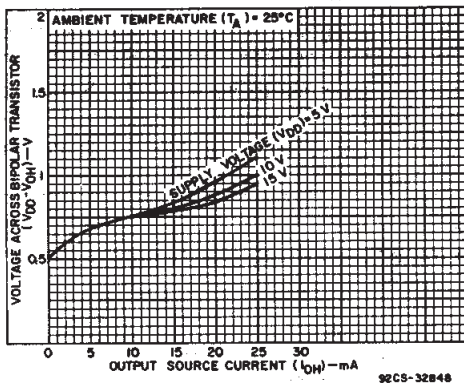

Fig. 9 - Voltage across bipolar transistor vs. output source current.

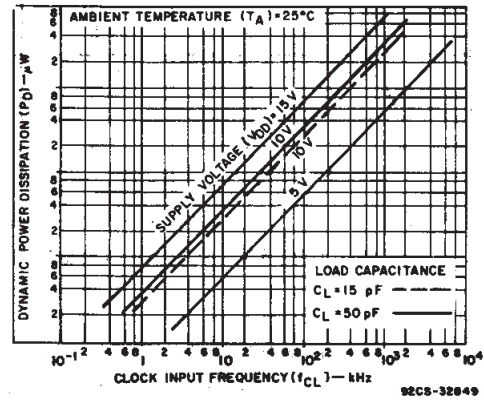

Fig. 10 - Typical dynamic power dissipation vs. frequency.

## TEST CIRCUITS

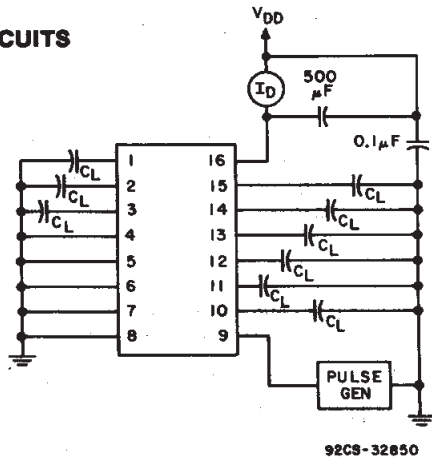

Fig. 11 - Dynamic power dissipation test circuit.

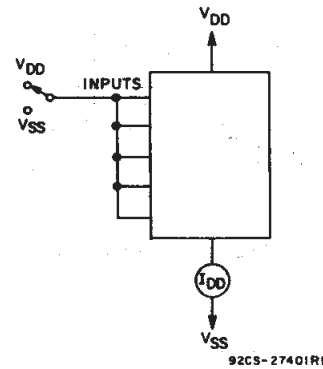

Fig. 12 - Quiescent device current.

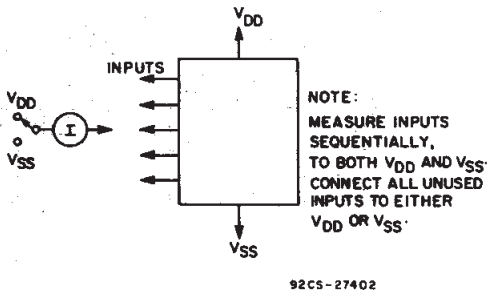

Fig. 13 - Input current.

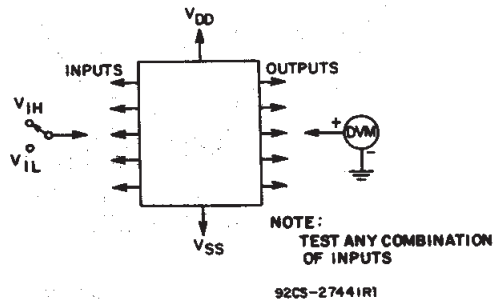

Fig. 14 - Input voltage.

## CD40110B Types

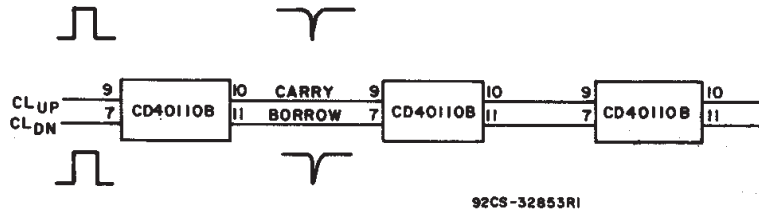
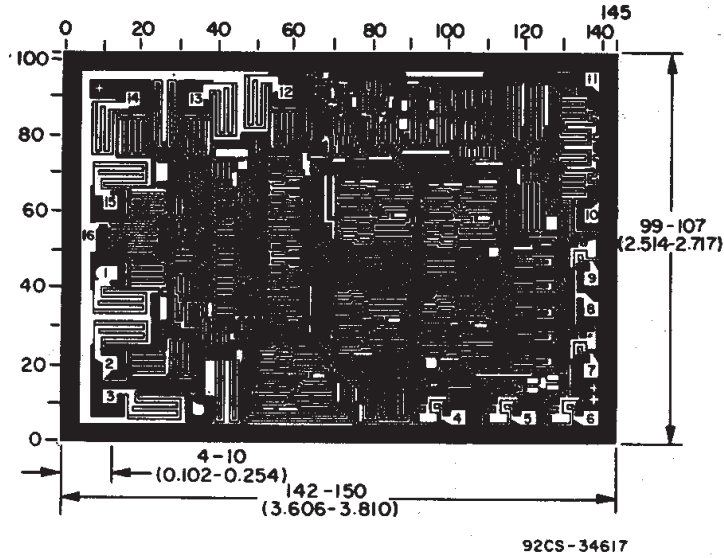

Fig. 15 - Cascading diagram.



*Dimensions and pad layout for CD40110B.*

*Dimensions in parentheses are in millimeters and are derived from the basic inch dimensions as indicated. Grid graduations are in mils ( $10^{-3}$  inch).*

3  
COMMERCIAL CMOS  
HIGH VOLTAGE ICs

**PACKAGING INFORMATION**

Orderable Device	Status <sup>(1)</sup>	Package Type	Package Drawing	Pins	Package Qty	Eco Plan <sup>(2)</sup>	Lead/Ball Finish	MSL Peak Temp <sup>(3)</sup>
CD40110BE	ACTIVE	PDIP	N	16	25	Pb-Free (RoHS)	CU NIPDAU	N / A for Pkg Type
CD40110BEE4	ACTIVE	PDIP	N	16	25	Pb-Free (RoHS)	CU NIPDAU	N / A for Pkg Type

<sup>(1)</sup> The marketing status values are defined as follows:

**ACTIVE:** Product device recommended for new designs.

**LIFEBUY:** TI has announced that the device will be discontinued, and a lifetime-buy period is in effect.

**NRND:** Not recommended for new designs. Device is in production to support existing customers, but TI does not recommend using this part in a new design.

**PREVIEW:** Device has been announced but is not in production. Samples may or may not be available.

**OBsolete:** TI has discontinued the production of the device.

<sup>(2)</sup> Eco Plan - The planned eco-friendly classification: Pb-Free (RoHS), Pb-Free (RoHS Exempt), or Green (RoHS & no Sb/Br) - please check <http://www.ti.com/productcontent> for the latest availability information and additional product content details.

**TBD:** The Pb-Free/Green conversion plan has not been defined.

**Pb-Free (RoHS):** TI's terms "Lead-Free" or "Pb-Free" mean semiconductor products that are compatible with the current RoHS requirements for all 6 substances, including the requirement that lead not exceed 0.1% by weight in homogeneous materials. Where designed to be soldered at high temperatures, TI Pb-Free products are suitable for use in specified lead-free processes.

**Pb-Free (RoHS Exempt):** This component has a RoHS exemption for either 1) lead-based flip-chip solder bumps used between the die and package, or 2) lead-based die adhesive used between the die and leadframe. The component is otherwise considered Pb-Free (RoHS compatible) as defined above.

**Green (RoHS & no Sb/Br):** TI defines "Green" to mean Pb-Free (RoHS compatible), and free of Bromine (Br) and Antimony (Sb) based flame retardants (Br or Sb do not exceed 0.1% by weight in homogeneous material)

<sup>(3)</sup> MSL, Peak Temp. -- The Moisture Sensitivity Level rating according to the JEDEC industry standard classifications, and peak solder temperature.

**Important Information and Disclaimer:** The information provided on this page represents TI's knowledge and belief as of the date that it is provided. TI bases its knowledge and belief on information provided by third parties, and makes no representation or warranty as to the accuracy of such information. Efforts are underway to better integrate information from third parties. TI has taken and continues to take reasonable steps to provide representative and accurate information but may not have conducted destructive testing or chemical analysis on incoming materials and chemicals. TI and TI suppliers consider certain information to be proprietary, and thus CAS numbers and other limited information may not be available for release.

In no event shall TI's liability arising out of such information exceed the total purchase price of the TI part(s) at issue in this document sold by TI to Customer on an annual basis.

N (R-PDIP-T\*\*)

PLASTIC DUAL-IN-LINE PACKAGE

16 PINS SHOWN



- NOTES:
- A. All linear dimensions are in inches (millimeters).
  - B. This drawing is subject to change without notice.
  - C Falls within JEDEC MS-001, except 18 and 20 pin minimum body length (Dim A).
  - D The 20 pin end lead shoulder width is a vendor option, either half or full width.

4040049/E 12/2002

## IMPORTANT NOTICE

Texas Instruments Incorporated and its subsidiaries (TI) reserve the right to make corrections, modifications, enhancements, improvements, and other changes to its products and services at any time and to discontinue any product or service without notice. Customers should obtain the latest relevant information before placing orders and should verify that such information is current and complete. All products are sold subject to TI's terms and conditions of sale supplied at the time of order acknowledgment.

TI warrants performance of its hardware products to the specifications applicable at the time of sale in accordance with TI's standard warranty. Testing and other quality control techniques are used to the extent TI deems necessary to support this warranty. Except where mandated by government requirements, testing of all parameters of each product is not necessarily performed.

TI assumes no liability for applications assistance or customer product design. Customers are responsible for their products and applications using TI components. To minimize the risks associated with customer products and applications, customers should provide adequate design and operating safeguards.

TI does not warrant or represent that any license, either express or implied, is granted under any TI patent right, copyright, mask work right, or other TI intellectual property right relating to any combination, machine, or process in which TI products or services are used. Information published by TI regarding third-party products or services does not constitute a license from TI to use such products or services or a warranty or endorsement thereof. Use of such information may require a license from a third party under the patents or other intellectual property of the third party, or a license from TI under the patents or other intellectual property of TI.

Reproduction of TI information in TI data books or data sheets is permissible only if reproduction is without alteration and is accompanied by all associated warranties, conditions, limitations, and notices. Reproduction of this information with alteration is an unfair and deceptive business practice. TI is not responsible or liable for such altered documentation. Information of third parties may be subject to additional restrictions.

Resale of TI products or services with statements different from or beyond the parameters stated by TI for that product or service voids all express and any implied warranties for the associated TI product or service and is an unfair and deceptive business practice. TI is not responsible or liable for any such statements.

TI products are not authorized for use in safety-critical applications (such as life support) where a failure of the TI product would reasonably be expected to cause severe personal injury or death, unless officers of the parties have executed an agreement specifically governing such use. Buyers represent that they have all necessary expertise in the safety and regulatory ramifications of their applications, and acknowledge and agree that they are solely responsible for all legal, regulatory and safety-related requirements concerning their products and any use of TI products in such safety-critical applications, notwithstanding any applications-related information or support that may be provided by TI. Further, Buyers must fully indemnify TI and its representatives against any damages arising out of the use of TI products in such safety-critical applications.

TI products are neither designed nor intended for use in military/aerospace applications or environments unless the TI products are specifically designated by TI as military-grade or "enhanced plastic." Only products designated by TI as military-grade meet military specifications. Buyers acknowledge and agree that any such use of TI products which TI has not designated as military-grade is solely at the Buyer's risk, and that they are solely responsible for compliance with all legal and regulatory requirements in connection with such use.

TI products are neither designed nor intended for use in automotive applications or environments unless the specific TI products are designated by TI as compliant with ISO/TS 16949 requirements. Buyers acknowledge and agree that, if they use any non-designated products in automotive applications, TI will not be responsible for any failure to meet such requirements.

Following are URLs where you can obtain information on other Texas Instruments products and application solutions:

### Products

Amplifiers	<a href="http://amplifier.ti.com">amplifier.ti.com</a>
Data Converters	<a href="http://dataconverter.ti.com">dataconverter.ti.com</a>
DLP® Products	<a href="http://www.dlp.com">www.dlp.com</a>
DSP	<a href="http://dsp.ti.com">dsp.ti.com</a>
Clocks and Timers	<a href="http://www.ti.com/clocks">www.ti.com/clocks</a>
Interface	<a href="http://interface.ti.com">interface.ti.com</a>
Logic	<a href="http://logic.ti.com">logic.ti.com</a>
Power Mgmt	<a href="http://power.ti.com">power.ti.com</a>
Microcontrollers	<a href="http://microcontroller.ti.com">microcontroller.ti.com</a>
RFID	<a href="http://www.ti-rfid.com">www.ti-rfid.com</a>
RF/IF and ZigBee® Solutions	<a href="http://www.ti.com/lprf">www.ti.com/lprf</a>

### Applications

Audio	<a href="http://www.ti.com/audio">www.ti.com/audio</a>
Automotive	<a href="http://www.ti.com/automotive">www.ti.com/automotive</a>
Broadband	<a href="http://www.ti.com/broadband">www.ti.com/broadband</a>
Digital Control	<a href="http://www.ti.com/digitalcontrol">www.ti.com/digitalcontrol</a>
Medical	<a href="http://www.ti.com/medical">www.ti.com/medical</a>
Military	<a href="http://www.ti.com/military">www.ti.com/military</a>
Optical Networking	<a href="http://www.ti.com/opticalnetwork">www.ti.com/opticalnetwork</a>
Security	<a href="http://www.ti.com/security">www.ti.com/security</a>
Telephony	<a href="http://www.ti.com/telephony">www.ti.com/telephony</a>
Video & Imaging	<a href="http://www.ti.com/video">www.ti.com/video</a>
Wireless	<a href="http://www.ti.com/wireless">www.ti.com/wireless</a>

Mailing Address: Texas Instruments, Post Office Box 655303, Dallas, Texas 75265  
Copyright © 2009, Texas Instruments Incorporated

## Looking for pricing, stock, or lifecycle information?

Click below to explore more details on WIN SOURCE:

 [View CD4011](#) on WIN SOURCE

 [Texas Instruments](#) Information

## Optimize Your Supply Chain with WIN SOURCE Solutions

-  Global Sourcing Solution
-  Obsolete Management
-  Cost Control Management
-  Shortage Management
-  Alternative Solution
-  Excess Inventory Management