



## CD4027B CMOS Dual J-K Flip Flop

### 1 Features

- Set-reset capability
- Static flip-flop operation – retains state indefinitely with clock level either *high* or *low*
- Medium speed operation – 16 MHz (typical) clock toggle rate at 10 V
- Standardized symmetrical output characteristics
- 100% tested for quiescent current at 20 V
- Maximum input current of 1  $\mu$ A at 18 V over full package-temperature range; 100 nA at 18 V and 25°C
- Noise margin (over full package-temperature range):
  - 1 V at  $V_{DD} = 5$  V
  - 2 V at  $V_{DD} = 10$  V
  - 2.5 V at  $V_{DD} = 15$  V
- 5 V, 10 V, and 15 V parametric ratings
- Meets all requirements of JEDEC tentative standard No. 138, *standard specifications for description of 'B' series CMOS devices*

### 2 Applications

- Registers, counters, control circuits

### 3 Description

CD4027B is a single monolithic chip integrated circuit containing two identical complementary-symmetry J-K flip flops. Each flip-flop has provisions for individual J, K, Set, Reset, and Clock input signals. Buffered Q and  $\bar{Q}$  signals are provided as outputs. This input-output arrangement provides for compatible operation with the RCA-CD4013B dual D-type flip-flop.

The CD4027B is useful in performing control, register, and toggle functions. Logic levels present at the J and K inputs along with internal self-steering control the state of each flip-flop; changes in the flip-flop state are synchronous with the positive-going transition of the clock pulse. Set and reset functions are independent of the clock and are initiated when a high level signal is present at either the Set or Reset input.

The CD4027B types are supplied in 16-lead hermetic dual-in-line ceramic packages (F3A suffix), 16-lead dual-in-line plastic packages (E suffix), 16-lead small-outline packages (M, M96, MT, and NSR suffixes), and 16-lead thin shrink small-outline packages (PW and PWR suffixes).

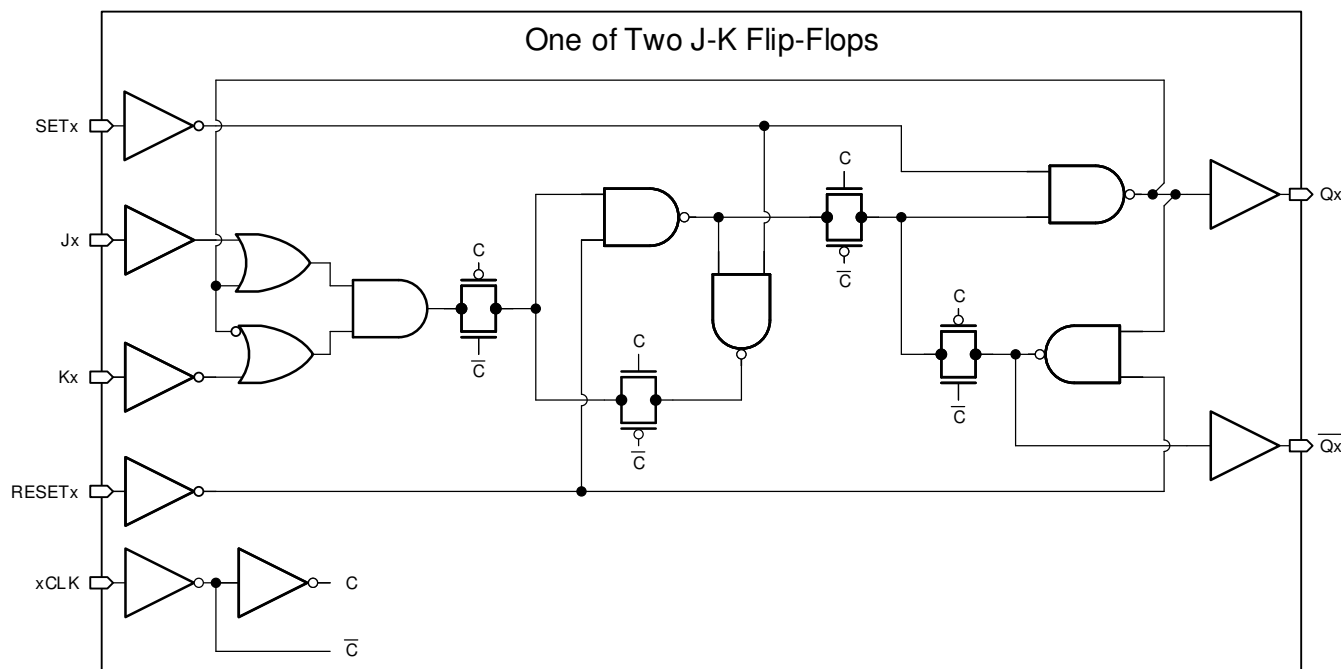

Figure 3-1. Logic Diagram



## Table of Contents

<b>1 Features</b> .....	<a href="#">1</a>	<b>8 Detailed Description</b> .....	<a href="#">9</a>
<b>2 Applications</b> .....	<a href="#">1</a>	8.1 Functional Block Diagram.....	<a href="#">9</a>
<b>3 Description</b> .....	<a href="#">1</a>	8.2 Device Functional Modes <sup>(1)</sup> .....	<a href="#">9</a>
<b>4 Revision History</b> .....	<a href="#">2</a>	<b>9 Device and Documentation Support</b> .....	<a href="#">10</a>
<b>5 Pin Configuration and Functions</b> .....	<a href="#">3</a>	9.1 Receiving Notification of Documentation Updates....	<a href="#">10</a>
<b>6 Specifications</b> .....	<a href="#">4</a>	9.2 Support Resources.....	<a href="#">10</a>
6.1 Absolute Maximum Ratings.....	<a href="#">4</a>	9.3 Trademarks.....	<a href="#">10</a>
6.2 Recommended Operating Conditions.....	<a href="#">4</a>	9.4 Electrostatic Discharge Caution.....	<a href="#">10</a>
6.3 Static Electrical Characteristics.....	<a href="#">5</a>	9.5 Glossary.....	<a href="#">10</a>
6.4 Dynamic Electrical Characteristics.....	<a href="#">5</a>	<b>10 Mechanical, Packaging, and Orderable</b>	
6.5 Typical Characteristics.....	<a href="#">7</a>	<b>Information</b> .....	<a href="#">10</a>
<b>7 Parameter Measurement Information</b> .....	<a href="#">8</a>		

## 4 Revision History

NOTE: Page numbers for previous revisions may differ from page numbers in the current version.

<b>Changes from Revision C (October 2003) to Revision D (July 2021)</b>	<b>Page</b>
• Updated the numbering format for tables, figures, and cross-references throughout the document.....	<a href="#">1</a>

## 5 Pin Configuration and Functions

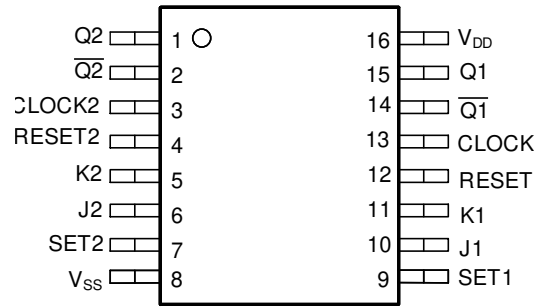

**Figure 5-1. Terminal Assignment**

**Table 5-1. Pin Functions**

PIN		I/O	DESCRIPTION
NAME	NO.		
CLOCK1	13	I	Clock input for channel 1
CLOCK2	3	I	Clock input for channel 2
J1	10	I	J input for channel 1
J2	6	I	J input for channel 2
K1	11	I	K input for channel 1
K2	5	I	K input for channel 2
Q1	15	O	Q output for channel 1
$\overline{Q1}$	14	O	Inverted Q output for channel 1
Q2	1	O	Q output for channel 2
$\overline{Q2}$	2	O	Inverted Q output for channel 2
RESET1	12	I	Reset input for channel 1
RESET2	4	I	Reset input for channel 2
SET1	9	I	Set input for channel 1
SET2	7	I	Set input for channel 2
V <sub>DD</sub>	16	—	Supply
V <sub>SS</sub>	8	—	Ground

## 6 Specifications

### 6.1 Absolute Maximum Ratings

			MIN	MAX	UNIT
V <sub>DD</sub>	DC Supply Voltage Range	Voltages referenced to V <sub>SS</sub> Terminal	-0.5	20	V
All Inputs	Input Voltage Range		-0.5	V <sub>DD</sub> + 0.5	V
Any One Input	DC Input Current			±10	mA
P <sub>D</sub>	Power Dissipation per Package	For T <sub>A</sub> = -55°C to +100°C		500	mW
		For T <sub>A</sub> = +100°C to +125°C	12mW/°C	200	mW
	Device Dissipation per Output Transistor	For T <sub>A</sub> = Full package-temperature range (all package types)		100	mW
T <sub>A</sub>	Operating- Temperature Range		-55	125	°C
T <sub>stg</sub>	Storage temperature		-65	150	°C
	Lead Temperature (During Soldering)	At distance 1/16 ± 1/32 inch (1.59 ± 0.79mm) from case for 10s max		265	°C

### 6.2 Recommended Operating Conditions

at T<sub>A</sub> = 25°C, except as noted. For maximum reliability, nominal operating conditions should be selected so that operation is always within the following ranges:

CHARACTERISTIC			V <sub>DD</sub> (V)	LIMITS		UNIT
				ALL PACKAGES		
				MIN	MAX	
	Supply-Voltage Range	For T <sub>A</sub> = Full Package Temperature Range		3	18	V
t <sub>S</sub>	Data Setup Time		5	200		ns
			10	75		
			15	50		
t <sub>W</sub>	Clock Pulse Width		5	140		ns
			10	60		
			15	40		
f <sub>CL</sub>	Clock Input Frequency (Toggle Mode)		5	3.5		MHz
			10	dc	8	
			15		12	
t <sub>rCL</sub> , t <sub>fCL</sub> (1)	Clock Rise or Fall Time		5	45		µs
			10	5		
			15	2		
t <sub>W</sub>	Set or Reset Pulse Width		5	180		ns
			10	80		
			15	50		

- (1) If more than one unite is cascaded in a parallel clocked operation, t<sub>rCL</sub> should be made less than or equal to the sum of the fixed propagation delay time at 15 pF and the transition time of the output driving stage for the estimated capacitive load.

### 6.3 Static Electrical Characteristics

CHARACTERISTIC	TEST CONDITIONS			LIMITS AT INDICATED TEMPERATURES (°C)						UNIT
	V <sub>O</sub> (V)	V <sub>IN</sub> (V)	V <sub>DD</sub> (V)	-55	-40	+85	+125	+25		
								MIN	TYP	
Quiescent Device Current I <sub>DD</sub> Max.		0, 5 0, 10 0, 15 0, 20	5 10 15 20	1 2 4 20	1 2 4 20	30 60 120 600	30 60 120 600	0.02 0.02 0.02 0.04	1 2 4 20	μA
Output Low (Sink) Current I <sub>OL</sub> Min.	0.4 0.5 1.5	0, 5 0, 10 0, 15	5 10 15	0.64 1.6 4.2	0.61 1.5 4	0.42 1.1 2.8	0.36 0.9 2.4	0.51 1.3 3.4	1 2.6 6.8	mA
Output High (Source) Current I <sub>OH</sub> Min.	4.6 2.5 9.5 13.5	0, 5 0, 5 0, 10 0, 15	5 5 10 15	-0.64 -2 -1.6 -4.2	-0.61 -1.8 -1.5 -4	-0.42 -1.3 -1.1 -2.8	-0.36 -1.15 -0.9 -2.4	-0.51 -1.6 -1.3 -3.4	-1 -3.2 -2.6 -6.8	mA
Output Voltage Low-Level V <sub>OL</sub> Max.		0, 5 0, 10 0, 15	5 10 15	0.05				0 0 0	0.05 0.05 0.05	V
Output Voltage High-Level V <sub>OH</sub> Min.		0, 5 0, 10 0, 15	5 10 15	4.95				4.95 9.95 14.95	5 10 15	V
Input Low Voltage V <sub>IL</sub> Max.	0.5, 4.5 1, 9 1.5, 13.5		5 10 15	1.5					1.5 3 4	V
Input High Voltage V <sub>IH</sub> Min.	0.5, 4.5 1, 9 1.5, 13.5		5 10 15	3.5				3.5 7 11		V
Input Current, V <sub>IH</sub> Max.		0, 18	18	±0.1	±0.1	±1	±1	±10 <sup>-5</sup>	±0.1	μA

### 6.4 Dynamic Electrical Characteristics

at T<sub>A</sub> = 25°C; Input t<sub>r</sub>, t<sub>f</sub> = 20 ns, C<sub>L</sub> = 50 pF, R<sub>L</sub> = 200 kΩ

CHARACTERISTIC	V <sub>DD</sub> (V)	LIMITS			UNIT
		ALL PACKAGES			
		MIN	TYP	MAX	
Propagation Delay Time Clock to Q or $\bar{Q}$ Outputs t <sub>PHL</sub> , t <sub>PLH</sub>	5 10 15		150 65 45	300 130 90	ns
Set to Q or Reset to $\bar{Q}$ , t <sub>PLH</sub>	5 10 15		150 65 45	300 130 90	ns
Set to $\bar{Q}$ or Reset to Q, t <sub>PHL</sub>	5 10 15		200 85 60	400 170 120	ns
Transition Time t <sub>THL</sub> , t <sub>TLH</sub>	5 10 15		100 50 40	200 100 80	ns

## 6.4 Dynamic Electrical Characteristics (continued)

at  $T_A = 25^\circ\text{C}$ ; Input  $t_r, t_f = 20\text{ ns}$ ,  $C_L = 50\text{ pF}$ ,  $R_L = 200\text{ k}\Omega$

CHARACTERISTIC	$V_{DD}$ (V)	LIMITS			UNIT
		ALL PACKAGES			
		MIN	TYP	MAX	
Maximum Clock Input Frequency (Toggle Mode) <sup>(1)</sup> $f_{CL}$	5	3.5	7		MHz
	10	8	16		
	15	12	24		
Minimum Clock Pulse Width, $t_{W}$	5		70	140	
	10		30	60	
	15		20	40	
Minimum Set or Reset Pulse Width, $t_{W}$	5		90	180	
	10		40	80	ns
	15		25	50	
Minimum Data Setup Time, $t_S$	5		100	200	
	10		35	75	
	15		25	50	
Clock Input Rise or Fall Time $t_{rCL}, t_{fCL}$	5			45	$\mu\text{s}$
	10			5	
	15			2	
Input Capacitance, $C_I$			5	7.5	pF

(1) Input  $t_r, t_f = 5\text{ ns}$

### 6.5 Typical Characteristics

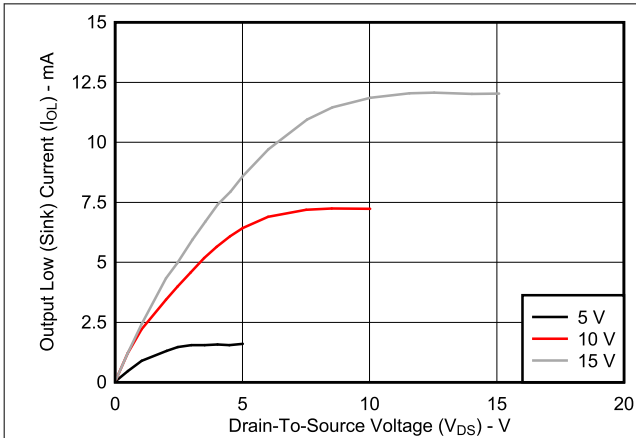

Figure 6-1. Typical Output Low (Sink) Current Characteristics

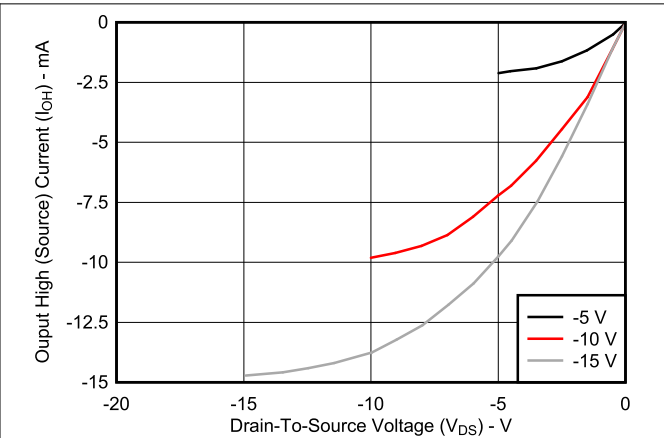

Figure 6-2. Typical Output High (Source) Current Characteristics

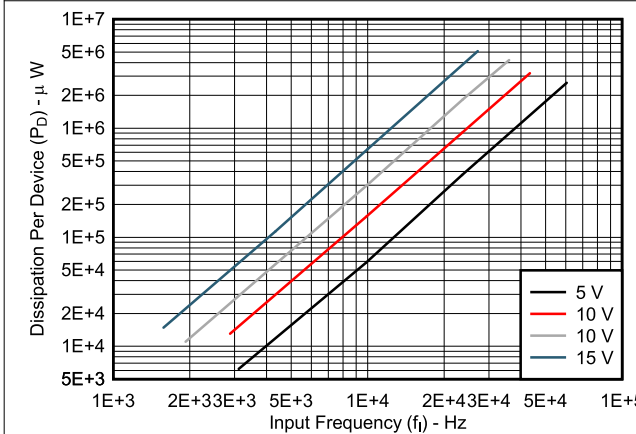

Figure 6-3. Typical Power Dissipation vs Frequency

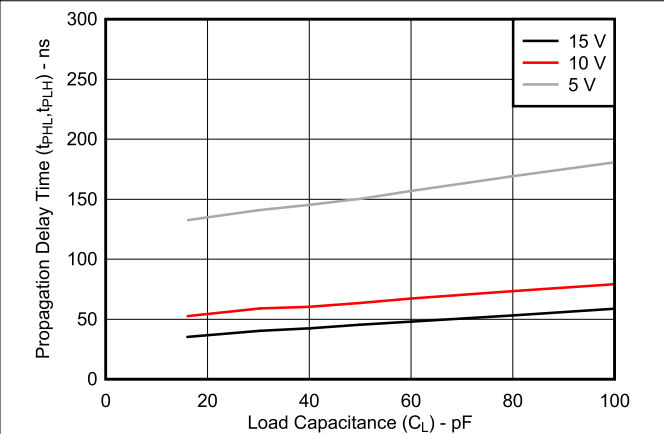

Figure 6-4. Typical Propagation Delay Time vs Load Capacitance (Clock or Set to Q, Clock or Reset to Q)

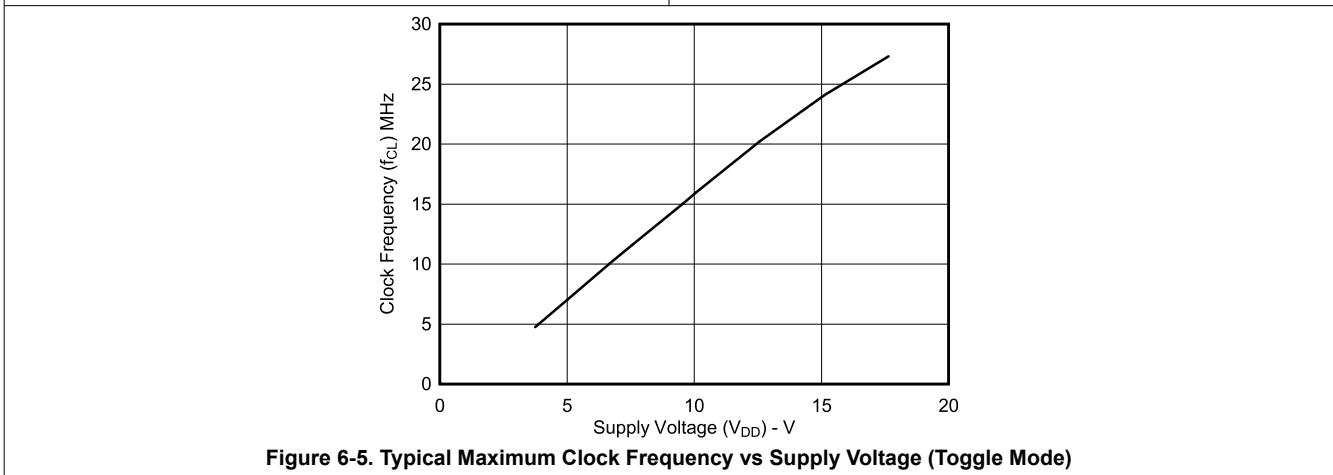

Figure 6-5. Typical Maximum Clock Frequency vs Supply Voltage (Toggle Mode)

## 7 Parameter Measurement Information

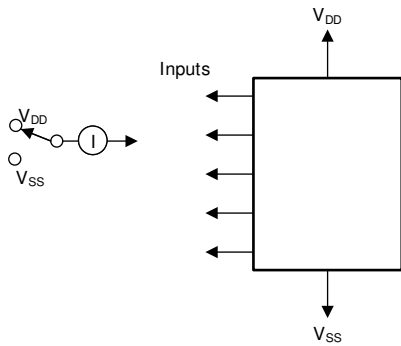

Figure 7-1. Input Current Test Circuit

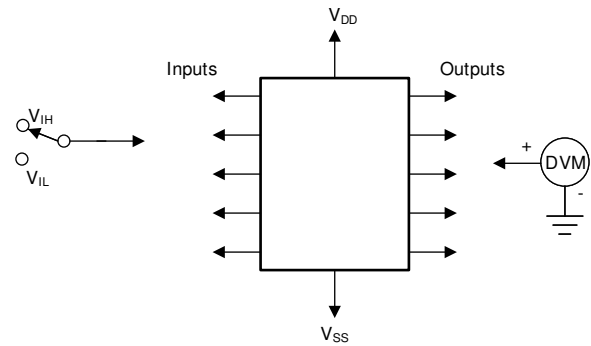

Figure 7-2. Input-Voltage Test Circuit

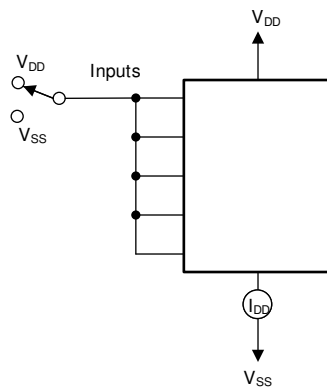
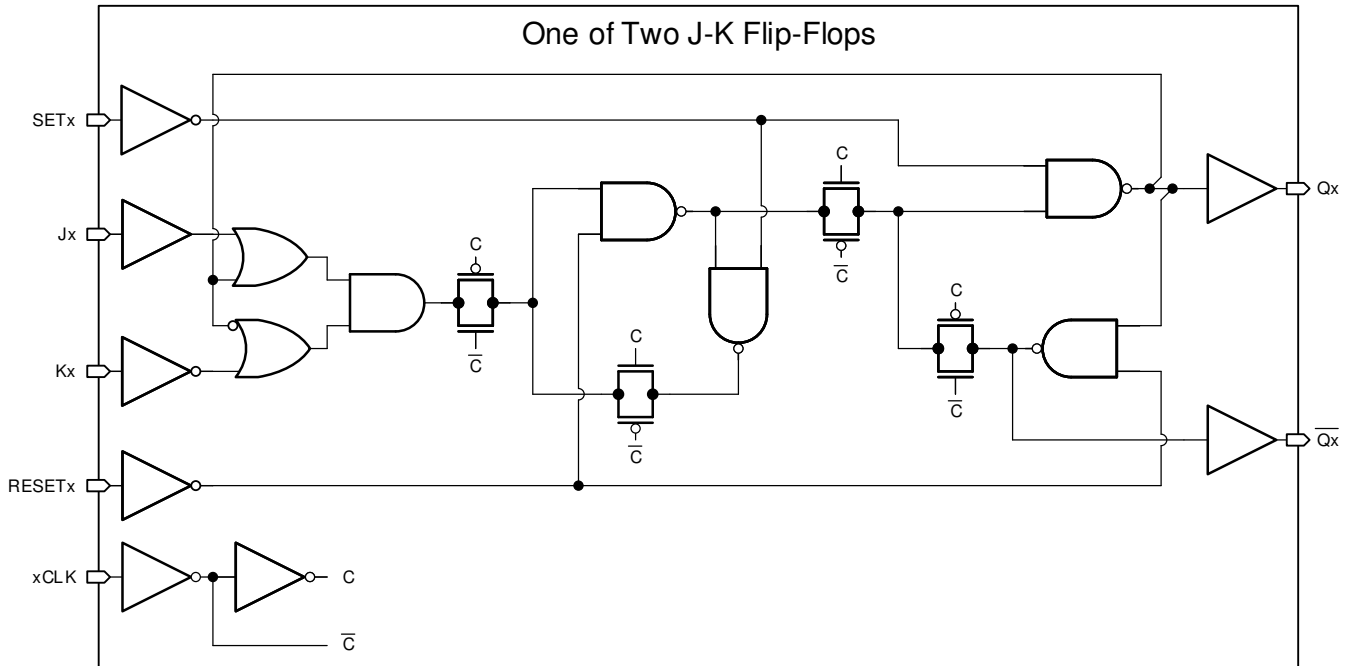

Figure 7-3. Quiescent Device Current Test Circuit

## 8 Detailed Description

### 8.1 Functional Block Diagram



### 8.2 Device Functional Modes<sup>(1)</sup>

PRESENT STATE				OUTPUT	CL <sup>(2)</sup>	NEXT STATE	
INPUTS						OUTPUTS	
J	K	S	R	O	$\downarrow$	O	$\bar{O}$
I	X	O	O	O	$\downarrow$	I	O
X	O	O	O	I	$\downarrow$	I	O
O	X	O	O	O	$\downarrow$	O	I
X	I	O	O	I	$\downarrow$	O	I
X	X	O	O	X	$\downarrow$	No change	No change
X	X	I	O	X	X	I	O
X	X	O	I	X	X	O	I
X	X	I	I	X	X	I	I

(1) Logic I = High Level, Logic O = Low Level, X = Do not care

(2) Level change

## 9 Device and Documentation Support

TI offers an extensive line of development tools. Tools and software to evaluate the performance of the device, generate code, and develop solutions are listed below.

### 9.1 Receiving Notification of Documentation Updates

To receive notification of documentation updates, navigate to the device product folder on [ti.com](http://ti.com). Click on *Subscribe to updates* to register and receive a weekly digest of any product information that has changed. For change details, review the revision history included in any revised document.

### 9.2 Support Resources

[TI E2E™ support forums](#) are an engineer's go-to source for fast, verified answers and design help — straight from the experts. Search existing answers or ask your own question to get the quick design help you need.

Linked content is provided "AS IS" by the respective contributors. They do not constitute TI specifications and do not necessarily reflect TI's views; see TI's [Terms of Use](#).

### 9.3 Trademarks

TI E2E™ is a trademark of Texas Instruments.

All trademarks are the property of their respective owners.

### 9.4 Electrostatic Discharge Caution



This integrated circuit can be damaged by ESD. Texas Instruments recommends that all integrated circuits be handled with appropriate precautions. Failure to observe proper handling and installation procedures can cause damage.

ESD damage can range from subtle performance degradation to complete device failure. Precision integrated circuits may be more susceptible to damage because very small parametric changes could cause the device not to meet its published specifications.

### 9.5 Glossary

[TI Glossary](#) This glossary lists and explains terms, acronyms, and definitions.

## 10 Mechanical, Packaging, and Orderable Information

The following pages include mechanical, packaging, and orderable information. This information is the most current data available for the designated devices. This data is subject to change without notice and revision of this document. For browser-based versions of this data sheet, refer to the left-hand navigation.

**PACKAGING INFORMATION**

Orderable Device	Status (1)	Package Type	Package Drawing	Pins	Package Qty	Eco Plan (2)	Lead finish/ Ball material (6)	MSL Peak Temp (3)	Op Temp (°C)	Device Marking (4/5)	Samples
CD4027BE	ACTIVE	PDIP	N	16	25	RoHS & Green	NIPDAU	N / A for Pkg Type	-55 to 125	CD4027BE	<a href="#">Samples</a>
CD4027BEE4	ACTIVE	PDIP	N	16	25	RoHS & Green	NIPDAU	N / A for Pkg Type	-55 to 125	CD4027BE	<a href="#">Samples</a>
CD4027BF	ACTIVE	CDIP	J	16	25	Non-RoHS & Green	SNPB	N / A for Pkg Type	-55 to 125	CD4027BF	<a href="#">Samples</a>
CD4027BF3A	ACTIVE	CDIP	J	16	25	Non-RoHS & Green	SNPB	N / A for Pkg Type	-55 to 125	CD4027BF3A	<a href="#">Samples</a>
CD4027BM96	ACTIVE	SOIC	D	16	2500	RoHS & Green	NIPDAU	Level-1-260C-UNLIM	-55 to 125	CD4027BM	<a href="#">Samples</a>
CD4027BM96E4	ACTIVE	SOIC	D	16	2500	RoHS & Green	NIPDAU	Level-1-260C-UNLIM	-55 to 125	CD4027BM	<a href="#">Samples</a>
CD4027BNSR	ACTIVE	SO	NS	16	2000	RoHS & Green	NIPDAU	Level-1-260C-UNLIM	-55 to 125	CD4027B	<a href="#">Samples</a>
CD4027BPWR	ACTIVE	TSSOP	PW	16	2000	RoHS & Green	NIPDAU	Level-1-260C-UNLIM	-55 to 125	CM027B	<a href="#">Samples</a>
JM38510/05152BEA	ACTIVE	CDIP	J	16	25	Non-RoHS & Green	SNPB	N / A for Pkg Type	-55 to 125	JM38510/ 05152BEA	<a href="#">Samples</a>
M38510/05152BEA	ACTIVE	CDIP	J	16	25	Non-RoHS & Green	SNPB	N / A for Pkg Type	-55 to 125	JM38510/ 05152BEA	<a href="#">Samples</a>

(1) The marketing status values are defined as follows:

**ACTIVE:** Product device recommended for new designs.

**LIFEBUY:** TI has announced that the device will be discontinued, and a lifetime-buy period is in effect.

**NRND:** Not recommended for new designs. Device is in production to support existing customers, but TI does not recommend using this part in a new design.

**PREVIEW:** Device has been announced but is not in production. Samples may or may not be available.

**OBSELETE:** TI has discontinued the production of the device.

(2) **RoHS:** TI defines "RoHS" to mean semiconductor products that are compliant with the current EU RoHS requirements for all 10 RoHS substances, including the requirement that RoHS substance do not exceed 0.1% by weight in homogeneous materials. Where designed to be soldered at high temperatures, "RoHS" products are suitable for use in specified lead-free processes. TI may reference these types of products as "Pb-Free".

**RoHS Exempt:** TI defines "RoHS Exempt" to mean products that contain lead but are compliant with EU RoHS pursuant to a specific EU RoHS exemption.

**Green:** TI defines "Green" to mean the content of Chlorine (Cl) and Bromine (Br) based flame retardants meet JS709B low halogen requirements of <=1000ppm threshold. Antimony trioxide based flame retardants must also meet the <=1000ppm threshold requirement.

(3) MSL, Peak Temp. - The Moisture Sensitivity Level rating according to the JEDEC industry standard classifications, and peak solder temperature.

(4) There may be additional marking, which relates to the logo, the lot trace code information, or the environmental category on the device.

(5) Multiple Device Markings will be inside parentheses. Only one Device Marking contained in parentheses and separated by a "~" will appear on a device. If a line is indented then it is a continuation of the previous line and the two combined represent the entire Device Marking for that device.

(6) Lead finish/Ball material - Orderable Devices may have multiple material finish options. Finish options are separated by a vertical ruled line. Lead finish/Ball material values may wrap to two lines if the finish value exceeds the maximum column width.

**Important Information and Disclaimer:**The information provided on this page represents TI's knowledge and belief as of the date that it is provided. TI bases its knowledge and belief on information provided by third parties, and makes no representation or warranty as to the accuracy of such information. Efforts are underway to better integrate information from third parties. TI has taken and continues to take reasonable steps to provide representative and accurate information but may not have conducted destructive testing or chemical analysis on incoming materials and chemicals. TI and TI suppliers consider certain information to be proprietary, and thus CAS numbers and other limited information may not be available for release.

In no event shall TI's liability arising out of such information exceed the total purchase price of the TI part(s) at issue in this document sold by TI to Customer on an annual basis.

**OTHER QUALIFIED VERSIONS OF CD4027B, CD4027B-MIL :**

- Catalog : [CD4027B](#)
- Military : [CD4027B-MIL](#)

NOTE: Qualified Version Definitions:

- Catalog - TI's standard catalog product
- Military - QML certified for Military and Defense Applications

**TAPE AND REEL INFORMATION**

**QUADRANT ASSIGNMENTS FOR PIN 1 ORIENTATION IN TAPE**

\*All dimensions are nominal

Device	Package Type	Package Drawing	Pins	SPQ	Reel Diameter (mm)	Reel Width W1 (mm)	A0 (mm)	B0 (mm)	K0 (mm)	P1 (mm)	W (mm)	Pin1 Quadrant
CD4027BM96	SOIC	D	16	2500	330.0	16.4	6.5	10.3	2.1	8.0	16.0	Q1
CD4027BNSR	SO	NS	16	2000	330.0	16.4	8.2	10.5	2.5	12.0	16.0	Q1
CD4027BPWR	TSSOP	PW	16	2000	330.0	12.4	6.9	5.6	1.6	8.0	12.0	Q1

## TAPE AND REEL BOX DIMENSIONS

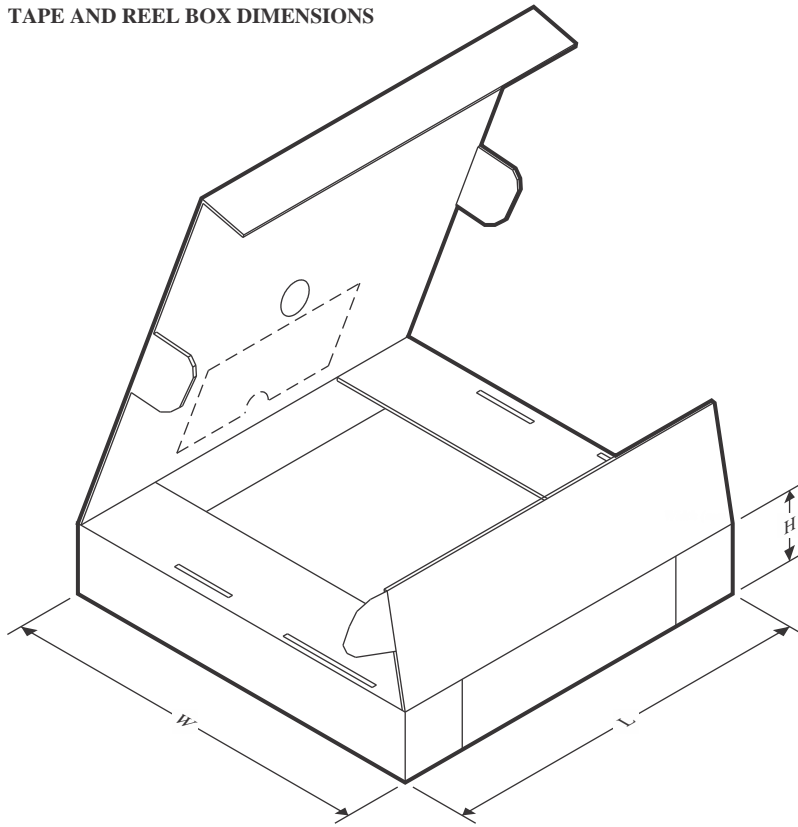

\*All dimensions are nominal

Device	Package Type	Package Drawing	Pins	SPQ	Length (mm)	Width (mm)	Height (mm)
CD4027BM96	SOIC	D	16	2500	340.5	336.1	32.0
CD4027BNSR	SO	NS	16	2000	356.0	356.0	35.0
CD4027BPWR	TSSOP	PW	16	2000	356.0	356.0	35.0

**TUBE**

\*All dimensions are nominal

Device	Package Name	Package Type	Pins	SPQ	L (mm)	W (mm)	T (μm)	B (mm)
CD4027BE	N	PDIP	16	25	506	13.97	11230	4.32
CD4027BE	N	PDIP	16	25	506	13.97	11230	4.32
CD4027BEE4	N	PDIP	16	25	506	13.97	11230	4.32
CD4027BEE4	N	PDIP	16	25	506	13.97	11230	4.32

N (R-PDIP-T\*\*)

PLASTIC DUAL-IN-LINE PACKAGE

16 PINS SHOWN



4040049/E 12/2002

- NOTES:
- A. All linear dimensions are in inches (millimeters).
  - B. This drawing is subject to change without notice.
  - (C) Falls within JEDEC MS-001, except 18 and 20 pin minimum body length (Dim A).
  - (D) The 20 pin end lead shoulder width is a vendor option, either half or full width.



# PACKAGE OUTLINE

## NS0016A

### SOP - 2.00 mm max height

SOP



#### NOTES:

1. All linear dimensions are in millimeters. Dimensions in parenthesis are for reference only. Dimensioning and tolerancing per ASME Y14.5M.
2. This drawing is subject to change without notice.
3. This dimension does not include mold flash, protrusions, or gate burrs. Mold flash, protrusions, or gate burrs shall not exceed 0.15 mm, per side.
4. This dimension does not include interlead flash. Interlead flash shall not exceed 0.25 mm, per side.

# EXAMPLE BOARD LAYOUT

NS0016A

SOP - 2.00 mm max height

SOP



SOLDER MASK DETAILS

4220735/A 12/2021

NOTES: (continued)

5. Publication IPC-7351 may have alternate designs.

6. Solder mask tolerances between and around signal pads can vary based on board fabrication site.

# EXAMPLE STENCIL DESIGN

NS0016A

SOP - 2.00 mm max height

SOP



SOLDER PASTE EXAMPLE  
BASED ON 0.125 mm THICK STENCIL  
SCALE:7X

4220735/A 12/2021

NOTES: (continued)

7. Laser cutting apertures with trapezoidal walls and rounded corners may offer better paste release. IPC-7525 may have alternate design recommendations.
8. Board assembly site may have different recommendations for stencil design.

J (R-GDIP-T\*\*)

14 LEADS SHOWN

CERAMIC DUAL IN-LINE PACKAGE



DIM \ PINS **	14	16	18	20
A	0.300 (7,62) BSC	0.300 (7,62) BSC	0.300 (7,62) BSC	0.300 (7,62) BSC
B MAX	0.785 (19,94)	.840 (21,34)	0.960 (24,38)	1.060 (26,92)
B MIN	—	—	—	—
C MAX	0.300 (7,62)	0.300 (7,62)	0.310 (7,87)	0.300 (7,62)
C MIN	0.245 (6,22)	0.245 (6,22)	0.220 (5,59)	0.245 (6,22)



4040083/F 03/03

- NOTES:
- All linear dimensions are in inches (millimeters).
  - This drawing is subject to change without notice.
  - This package is hermetically sealed with a ceramic lid using glass frit.
  - Index point is provided on cap for terminal identification only on press ceramic glass frit seal only.
  - Falls within MIL STD 1835 GDIP1-T14, GDIP1-T16, GDIP1-T18 and GDIP1-T20.

D (R-PDSO-G16)

PLASTIC SMALL OUTLINE



- NOTES:
- A. All linear dimensions are in inches (millimeters).
  - B. This drawing is subject to change without notice.
  - C. Body length does not include mold flash, protrusions, or gate burrs. Mold flash, protrusions, or gate burrs shall not exceed 0.006 (0,15) each side.
  - D. Body width does not include interlead flash. Interlead flash shall not exceed 0.017 (0,43) each side.
  - E. Reference JEDEC MS-012 variation AC.



4220204/A 02/2017

NOTES:

1. All linear dimensions are in millimeters. Any dimensions in parenthesis are for reference only. Dimensioning and tolerancing per ASME Y14.5M.
2. This drawing is subject to change without notice.
3. This dimension does not include mold flash, protrusions, or gate burrs. Mold flash, protrusions, or gate burrs shall not exceed 0.15 mm per side.
4. This dimension does not include interlead flash. Interlead flash shall not exceed 0.25 mm per side.
5. Reference JEDEC registration MO-153.

# EXAMPLE BOARD LAYOUT

PW0016A

TSSOP - 1.2 mm max height

SMALL OUTLINE PACKAGE



LAND PATTERN EXAMPLE  
EXPOSED METAL SHOWN  
SCALE: 10X



4220204/A 02/2017

NOTES: (continued)

- 6. Publication IPC-7351 may have alternate designs.
- 7. Solder mask tolerances between and around signal pads can vary based on board fabrication site.

# EXAMPLE STENCIL DESIGN

PW0016A

TSSOP - 1.2 mm max height

SMALL OUTLINE PACKAGE



SOLDER PASTE EXAMPLE  
BASED ON 0.125 mm THICK STENCIL  
SCALE: 10X

4220204/A 02/2017

NOTES: (continued)

8. Laser cutting apertures with trapezoidal walls and rounded corners may offer better paste release. IPC-7525 may have alternate design recommendations.
9. Board assembly site may have different recommendations for stencil design.

# MECHANICAL DATA

NS (R-PDSO-G\*\*)

PLASTIC SMALL-OUTLINE PACKAGE

14-PINS SHOWN



- NOTES:
- A. All linear dimensions are in millimeters.
  - B. This drawing is subject to change without notice.
  - C. Body dimensions do not include mold flash or protrusion, not to exceed 0,15.

## IMPORTANT NOTICE AND DISCLAIMER

TI PROVIDES TECHNICAL AND RELIABILITY DATA (INCLUDING DATA SHEETS), DESIGN RESOURCES (INCLUDING REFERENCE DESIGNS), APPLICATION OR OTHER DESIGN ADVICE, WEB TOOLS, SAFETY INFORMATION, AND OTHER RESOURCES "AS IS" AND WITH ALL FAULTS, AND DISCLAIMS ALL WARRANTIES, EXPRESS AND IMPLIED, INCLUDING WITHOUT LIMITATION ANY IMPLIED WARRANTIES OF MERCHANTABILITY, FITNESS FOR A PARTICULAR PURPOSE OR NON-INFRINGEMENT OF THIRD PARTY INTELLECTUAL PROPERTY RIGHTS.

These resources are intended for skilled developers designing with TI products. You are solely responsible for (1) selecting the appropriate TI products for your application, (2) designing, validating and testing your application, and (3) ensuring your application meets applicable standards, and any other safety, security, regulatory or other requirements.

These resources are subject to change without notice. TI grants you permission to use these resources only for development of an application that uses the TI products described in the resource. Other reproduction and display of these resources is prohibited. No license is granted to any other TI intellectual property right or to any third party intellectual property right. TI disclaims responsibility for, and you will fully indemnify TI and its representatives against, any claims, damages, costs, losses, and liabilities arising out of your use of these resources.

TI's products are provided subject to [TI's Terms of Sale](#) or other applicable terms available either on [ti.com](https://www.ti.com) or provided in conjunction with such TI products. TI's provision of these resources does not expand or otherwise alter TI's applicable warranties or warranty disclaimers for TI products.

TI objects to and rejects any additional or different terms you may have proposed.

Mailing Address: Texas Instruments, Post Office Box 655303, Dallas, Texas 75265  
Copyright © 2024, Texas Instruments Incorporated

## Looking for pricing, stock, or lifecycle information?

Click below to explore more details on WIN SOURCE:

 [View CD4027BF](#) on WIN SOURCE

 [Texas Instruments](#) Information

## Optimize Your Supply Chain with WIN SOURCE Solutions

-  Global Sourcing Solution
-  Obsolete Management
-  Cost Control Management
-  Shortage Management
-  Alternative Solution
-  Excess Inventory Management