



**THE DATASHEET OF
LT3695EMSE-5#PBF**



FEATURES

- **Wide Input Range:**
 Operation from 3.6V to 36V
 Overvoltage Lockout Protects Circuits Through 60V Transients
- **FMEA Fault Tolerant:**
 Output Stays at or Below Regulation Voltage During Adjacent Pin Short or When a Pin Is Left Floating
- **1A Output Current**
- **Low Ripple (< 15mV_{P-P}) Burst Mode® Operation**
 $I_Q = 75\mu\text{A}$ for 12V_{IN} to 3.3V_{OUT} with No Load
- **Adjustable Switching Frequency: 250kHz to 2.2MHz**
- **Short-Circuit Protected**
- **Synchronizable Between 300kHz and 2.2MHz**
- Output Voltage: 0.8V to 20V
- Power Good Flag
- Fixed Output Voltage Versions for 3.3V and 5V Available
- Small, Thermally Enhanced 16-Pin MSOP Package

APPLICATIONS

- Automotive Battery Regulation
- Automotive Entertainment Systems
- Distributed Supply Regulation
- Industrial Supplies

LT, LT, LTC, LTM, Burst Mode, Linear Technology and the Linear logo are registered trademarks of Linear Technology Corporation. All other trademarks are the property of their respective owners.

DESCRIPTION

The LT[®]3695 series are adjustable frequency (250kHz to 2.2MHz) monolithic buck switching regulators that accept input voltages up to 36V and can safely sustain transient voltages up to 60V. The devices include a high efficiency switch, a boost diode, and the necessary oscillator, control and logic circuitry. Current mode topology is used for fast transient response and good loop stability. A SYNC pin allows the user to synchronize the part to an external clock, and to choose between low ripple Burst Mode operation and standard PWM operation.

The LT3695 regulators tolerate adjacent pin shorts or an open pin without raising the output voltage above its programmed value.

Low ripple Burst Mode operation maintains high efficiency at low output currents while keeping output ripple below 15mV in a typical application. Shutdown reduces input supply current to less than 1μA while a resistor and capacitor on the RUN/SS pin provide a controlled output voltage ramp (soft-start). Protection circuitry senses the current in the power switch and external Schottky catch diode to protect the LT3695 regulators against short-circuit conditions. Frequency foldback and thermal shutdown provide additional protection.

The LT3695 series is available in a thermally enhanced 16-pin MSOP package.

TYPICAL APPLICATION

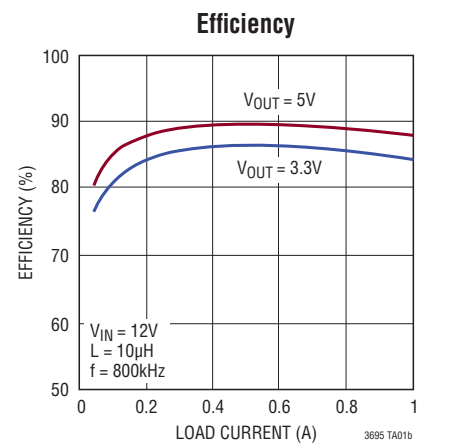
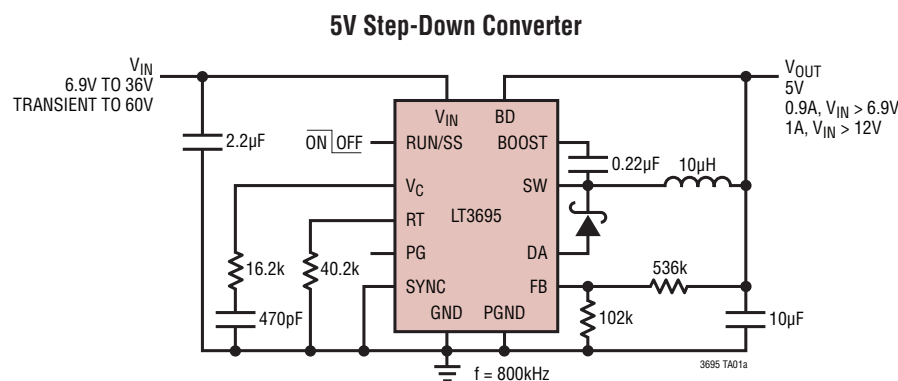

LT3695 Series

ABSOLUTE MAXIMUM RATINGS (Notes 1, 2)

| | | | |
|---|-----|---|----------------|
| V_{IN} , RUN/SS Voltage (Note 3)..... | 60V | OUT1, OUT2 Voltage (LT3695-3.3, LT3695-5)..... | 16V |
| BOOST Pin Voltage | 50V | PG Voltage | 30V |
| BOOST Pin Above SW Pin..... | 30V | Operating Junction Temperature Range (Notes 4, 5) | |
| BD Voltage (LT3695) | 30V | LT3695E | -40°C to 125°C |
| RT, V_C Voltage | 5V | LT3695I..... | -40°C to 125°C |
| RT Pin Current | 1mA | LT3695H | -40°C to 150°C |
| SYNC Voltage..... | 20V | Storage Temperature Range..... | -65°C to 150°C |
| FB Voltage (LT3695)..... | 5V | Lead Temperature (Soldering, 10 sec) | 300°C |

PIN CONFIGURATION

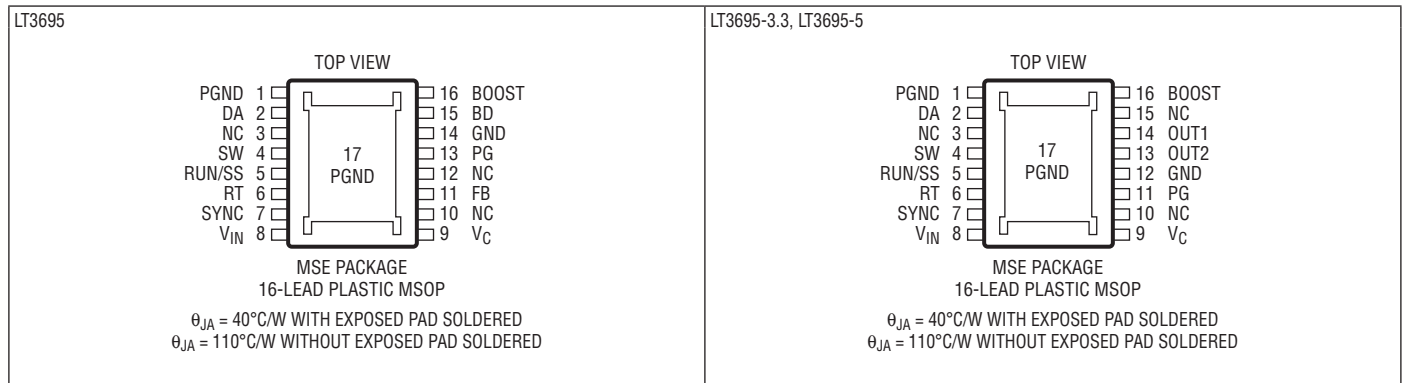

ORDER INFORMATION

| LEAD FREE FINISH | TAPE AND REEL | PART MARKING* | PACKAGE DESCRIPTION | TEMPERATURE RANGE |
|--------------------|----------------------|---------------|----------------------|-------------------|
| LT3695EMSE#PBF | LT3695EMSE#TRPBF | 3695 | 16-Lead Plastic MSOP | -40°C to 125°C |
| LT3695IMSE#PBF | LT3695IMSE#TRPBF | 3695 | 16-Lead Plastic MSOP | -40°C to 125°C |
| LT3695HMSE#PBF | LT3695HMSE#TRPBF | 3695 | 16-Lead Plastic MSOP | -40°C to 150°C |
| LT3695EMSE-3.3#PBF | LT3695EMSE-3.3#TRPBF | 369533 | 16-Lead Plastic MSOP | -40°C to 125°C |
| LT3695IMSE-3.3#PBF | LT3695IMSE-3.3#TRPBF | 369533 | 16-Lead Plastic MSOP | -40°C to 125°C |
| LT3695HMSE-3.3#PBF | LT3695HMSE-3.3#TRPBF | 369533 | 16-Lead Plastic MSOP | -40°C to 150°C |
| LT3695EMSE-5#PBF | LT3695EMSE-5#TRPBF | 36955 | 16-Lead Plastic MSOP | -40°C to 125°C |
| LT3695IMSE-5#PBF | LT3695IMSE-5#TRPBF | 36955 | 16-Lead Plastic MSOP | -40°C to 125°C |
| LT3695HMSE-5#PBF | LT3695HMSE-5#TRPBF | 36955 | 16-Lead Plastic MSOP | -40°C to 150°C |

Consult LTC Marketing for parts specified with wider operating temperature ranges. *The temperature grade is identified by a label on the shipping container. Consult LTC Marketing for information on non-standard lead based finish parts.

For more information on lead free part marking, go to: <http://www.linear.com/leadfree/>

For more information on tape and reel specifications, go to: <http://www.linear.com/tapeandreeel/>

ELECTRICAL CHARACTERISTICS

The ● denotes the specifications which apply over the full operating temperature range, otherwise specifications are at $T_A = 25^\circ\text{C}$. $V_{IN} = 10\text{V}$, $V_{RUN/SS} = 10\text{V}$, unless otherwise noted. (Note 4)

| PARAMETER | CONDITIONS | | MIN | TYP | MAX | UNITS |
|--|---|---|-------|-------|-------|---------------|
| Minimum Operating Voltage (Note 6) LT3695 | $V_{BD} = 3.3\text{V}$ $V_{BD} < 3\text{V}$ | ● | | 3.4 | 3.6 | V |
| | | ● | | 3.4 | 4.3 | V |
| LT3695-3.3 | $V_{OUT1,2} = 3.3\text{V}$ | ● | | 3.4 | 3.6 | V |
| LT3695-5 | $V_{OUT1,2} = 5\text{V}$ | ● | | 3.4 | 3.6 | V |
| V_{IN} Overvoltage Lockout | | ● | 36 | 38 | 39.9 | V |
| Quiescent Current from V_{IN} LT3695 | $V_{RUN/SS} = 0.2\text{V}$, $V_{BD} = 3.3\text{V}$ $V_{RUN/SS} = 10\text{V}$, $V_{BD} = 3.3\text{V}$, Not Switching $V_{RUN/SS} = 10\text{V}$, $V_{BD} = 0\text{V}$, Not Switching | ● | | 0.01 | 0.5 | μA |
| | | ● | | 35 | 60 | μA |
| | | ● | | 90 | 160 | μA |
| | | ● | | 35 | 60 | μA |
| LT3695-3.3 | $V_{RUN/SS} = 10\text{V}$, $V_{OUT1,2} = 3.3\text{V}$, Not Switching | ● | | 35 | 60 | μA |
| LT3695-5 | $V_{RUN/SS} = 10\text{V}$, $V_{OUT1,2} = 5\text{V}$, Not Switching | ● | | 35 | 60 | μA |
| Quiescent Current from BD Pin LT3695 | $V_{RUN/SS} = 0.2\text{V}$, $V_{BD} = 3.3\text{V}$ $V_{RUN/SS} = 10\text{V}$, $V_{BD} = 3.3\text{V}$, Not Switching $V_{RUN/SS} = 10\text{V}$, $V_{BD} = 0\text{V}$, Not Switching | ● | 35 | 0.01 | 0.5 | μA |
| | | ● | | 55 | 100 | μA |
| | | ● | | 0 | -5 | μA |
| Quiescent Current from OUT1,2 Pins LT3695-3.3 | $V_{RUN/SS} = 0.2\text{V}$ $V_{RUN/SS} = 10\text{V}$, $V_{OUT1,2} = 3.3\text{V}$, Not Switching | ● | 5 | 10 | 15 | μA |
| | | ● | 43 | 65 | 112 | μA |
| LT3695-5 | $V_{RUN/SS} = 0.2\text{V}$ $V_{RUN/SS} = 10\text{V}$, $V_{OUT1,2} = 5\text{V}$, Not Switching | ● | 5 | 10 | 15 | μA |
| | | ● | 43 | 65 | 112 | μA |
| Minimum BD Pin Voltage: LT3695 | | | | 2.8 | 3 | V |
| Feedback Voltage: LT3695 | | ● | 792 | 800 | 808 | mV |
| | | ● | 785 | 800 | 815 | mV |
| FB Pin Bias Current: LT3695 | FB Pin Voltage = 800mV | ● | | -5 | -40 | nA |
| Reference Voltage Line Regulation | $3.6\text{V} < V_{IN} < 36\text{V}$ | | | 0.001 | 0.005 | %/V |
| Output Voltage LT3695-3.3 | | ● | 3.27 | 3.3 | 3.33 | V |
| | | ● | 3.25 | 3.3 | 3.35 | V |
| LT3695-5 | | ● | 4.95 | 5 | 5.05 | V |
| | | ● | 4.925 | 5 | 5.075 | V |
| Error Amp g_m | $I_{VC} = \pm 1.5\mu\text{A}$ | | | 430 | | μS |
| Error Amp Voltage Gain | | | | 1300 | | V/V |
| V_C Source Current | | | | 50 | | μA |
| V_C Sink Current | | | | 50 | | μA |
| V_C Pin to Switch Current Gain | | | | 1.25 | | A/V |
| V_C Switching Threshold | | | 0.4 | 0.6 | 0.8 | V |
| V_C Clamp Voltage | | | | 2 | | V |
| Switching Frequency | $R_{RT} = 8.06\text{k}$ $R_{RT} = 29.4\text{k}$ $R_{RT} = 158\text{k}$ | | 1.98 | 2.2 | 2.42 | MHz |
| | | | 0.9 | 1.0 | 1.1 | MHz |
| | | | 225 | 250 | 275 | kHz |
| Minimum Switch Off-Time | E- and I-Grades H-Grade | ● | | 130 | 210 | ns |
| | | ● | | 130 | 250 | ns |
| Switch Current Limit (Note 7) | SYNC = 0V SYNC = 3.3V or Clocked | | 1.45 | 1.7 | 2 | A |
| | | | 1.18 | 1.4 | 1.66 | A |

LT3695 Series

ELECTRICAL CHARACTERISTICS

The ● denotes the specifications which apply over the full operating temperature range, otherwise specifications are at $T_A = 25^\circ\text{C}$. $V_{IN} = 10\text{V}$, $V_{RUN/SS} = 10\text{V}$, unless otherwise noted. (Note 4)

| PARAMETER | CONDITIONS | MIN | TYP | MAX | UNITS | |
|--|--|------|-----------|-----------|--------------------------------|---|
| Switch V_{CESAT} | $I_{SW} = 1\text{A}$ | | 350 | | mV | |
| DA Pin Current to Stop OSC | | 1.25 | 1.6 | 1.95 | A | |
| Switch Leakage Current | $V_{SW} = 0\text{V}$, $V_{IN} = 36\text{V}$ | | 0.01 | 1 | μA | |
| Boost Schottky Diode Voltage Drop | $I_{BSD} = 50\text{mA}$ | | 720 | 900 | mV | |
| Boost Schottky Diode Reverse Leakage | $V_{SW} = 10\text{V}$, $V_{BD} = 0\text{V}$ | | 0.1 | 1 | μA | |
| Minimum Boost Voltage (Note 8) | | ● | 1.7 | 2.3 | V | |
| BOOST Pin Current | $I_{SW} = 0.5\text{A}$ | | 10.5 | 17.5 | mA | |
| RUN/SS Pin Current | $V_{RUN/SS} = 2.5\text{V}$ $V_{RUN/SS} = 10\text{V}$ | ● | 4.5 12 | 7.5 20 | μA μA | |
| RUN/SS Input Voltage High | | 2.5 | | | V | |
| RUN/SS Input Voltage Low | | | | 0.2 | V | |
| PG Leakage Current | $V_{PG} = 5\text{V}$ | | 0.1 | 1 | μA | |
| PG Sink Current | $V_{PG} = 0.4\text{V}$ | ● | 100 | 1000 | μA | |
| PG Threshold as % of V_{FB} (LT3695) or V_{OUT} (LT3695-3.3, LT3695-5) | Measured at FB (LT3695) or OUT1,2 (LT3695-3.3, LT3695-5) Pins (Pin Voltage Rising) | | 88 | 90 | 92 | % |
| PG Threshold Hysteresis | | | | | | |
| LT3695 | Measured at FB Pin | | 12 | | mV | |
| LT3695-3.3 | Measured at OUT1,2, Pins | | 50 | | mV | |
| LT3695-5 | Measured at OUT1,2, Pins | | 75 | | mV | |
| SYNC Threshold Voltage | | 300 | 550 | 800 | mV | |
| SYNC Input Frequency | | 0.3 | | 2.2 | MHz | |

Note 1: Stresses beyond those listed under absolute maximum ratings may cause permanent damage to the device. Exposure to any Absolute Maximum Rating condition for extended periods may affect the device reliability and lifetime.

Note 2: Positive currents flow into pins, negative currents flow out of pins. Minimum and maximum values refer to absolute values.

Note 3: Absolute maximum voltage at V_{IN} and RUN/SS pins is 60V for nonrepetitive 1 second transients, and 36V for continuous operation.

Note 4: The LT3695E regulators are guaranteed to meet performance specifications from 0°C to 125°C junction temperature. Specifications over the -40°C to 125°C operating junction temperature range are assured by design, characterization and correlation with statistical process controls. The LT3695I regulators are guaranteed over the full -40°C to 125°C operating junction temperature range. The LT3695H regulators are guaranteed over the full -40°C to 150°C operating junction temperature range.

Note 5: These ICs include overtemperature protection that is intended to protect the devices during momentary overload conditions. Junction temperature will exceed the maximum operating junction temperature when overtemperature protection is active. Continuous operation above the specified maximum operating junction temperature may impair device reliability.

Note 6: This is the voltage necessary to keep the internal bias circuitry in regulation.

Note 7: Current limit guaranteed by design and/or correlation to static test. Slope compensation reduces current limit at higher duty cycles.

Note 8: This is the minimum voltage across the boost capacitor needed to guarantee full saturation of the switch.

TYPICAL PERFORMANCE CHARACTERISTICS $T_A = 25^\circ\text{C}$, unless otherwise noted.

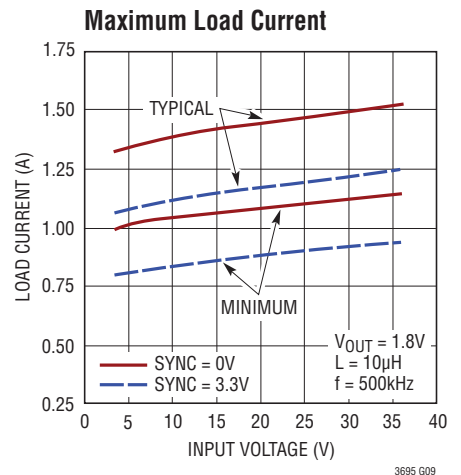
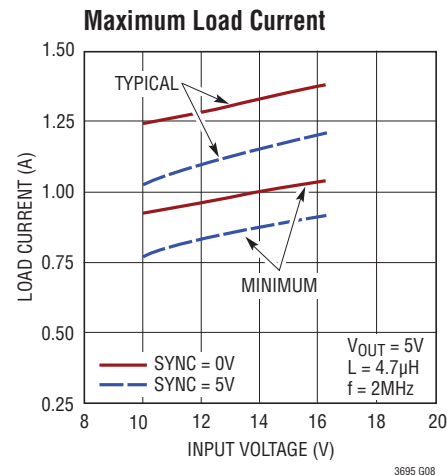
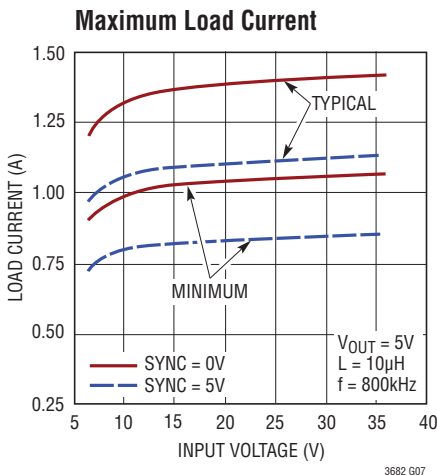
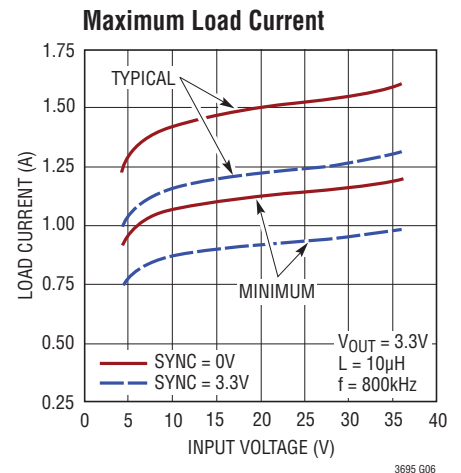
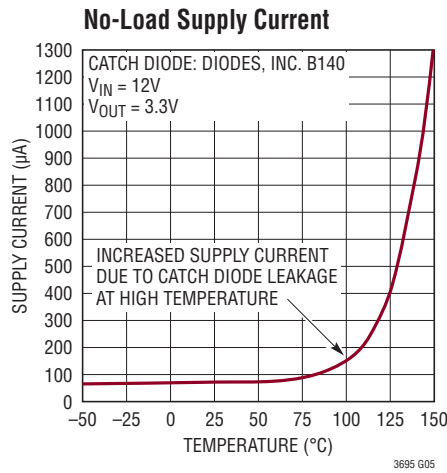
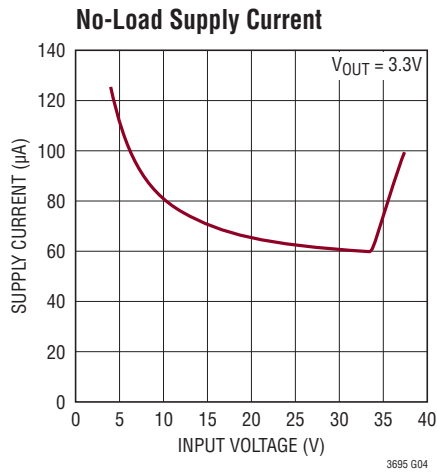
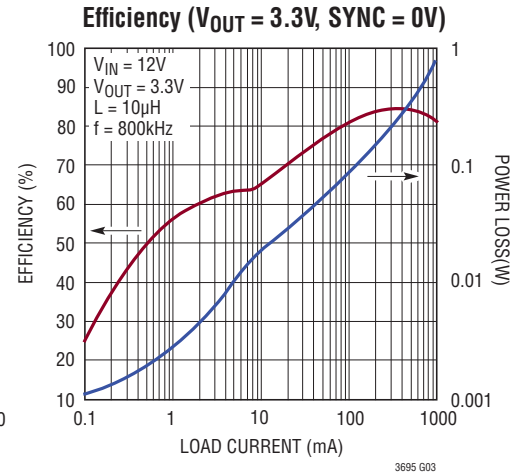
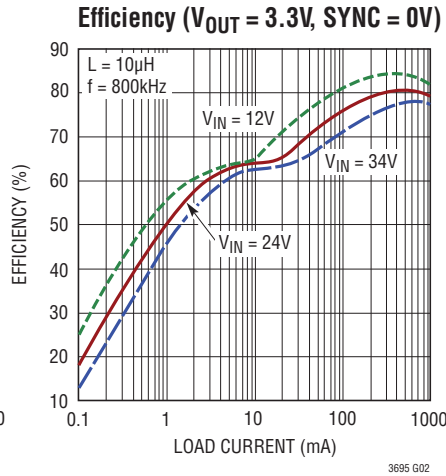
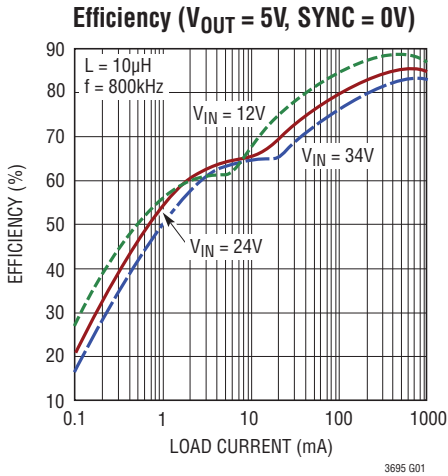

TYPICAL PERFORMANCE CHARACTERISTICS $T_A = 25^\circ\text{C}$, unless otherwise noted.

Switch Current Limit

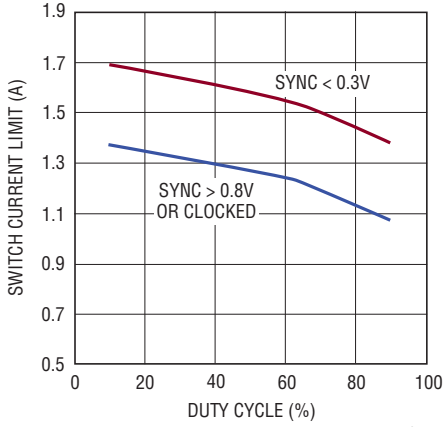

Switch Current Limit (SYNC Pin Grounded)

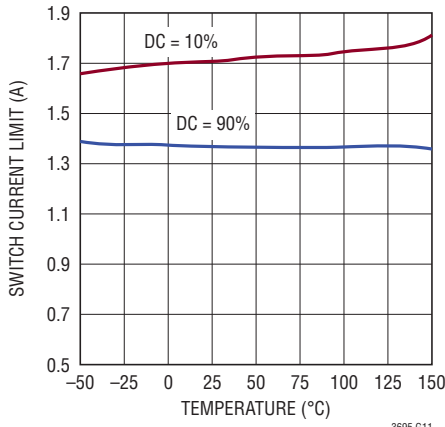

Switch Voltage Drop

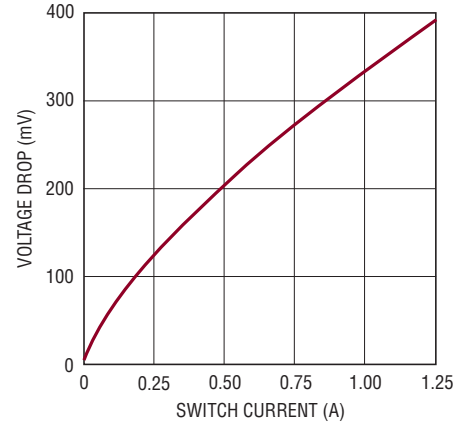

BOOST Pin Current

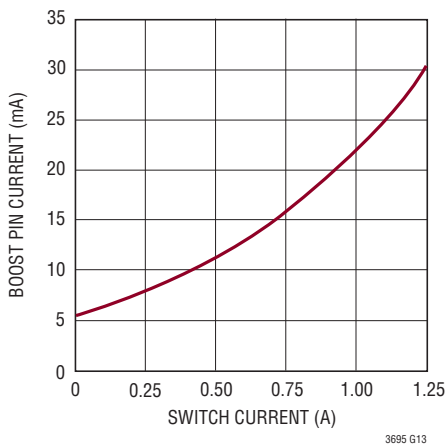

Feedback Voltage

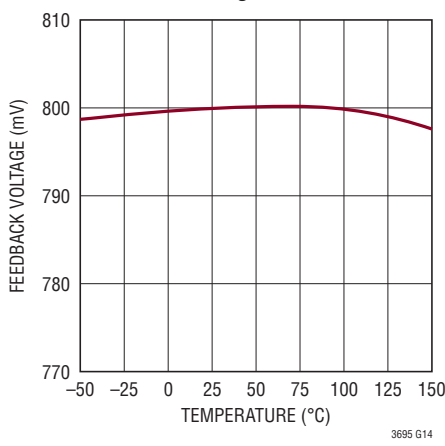

Output Voltage: LT3695-3.3, LT3695-5

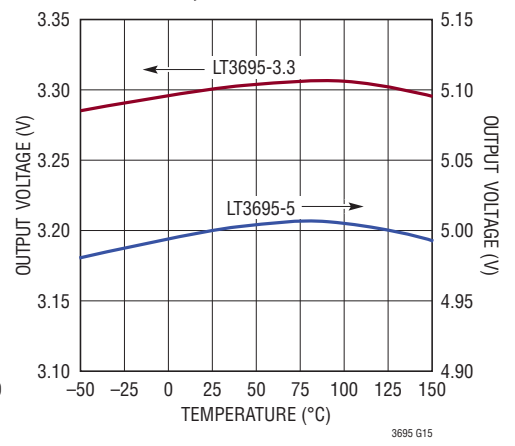

Switching Frequency

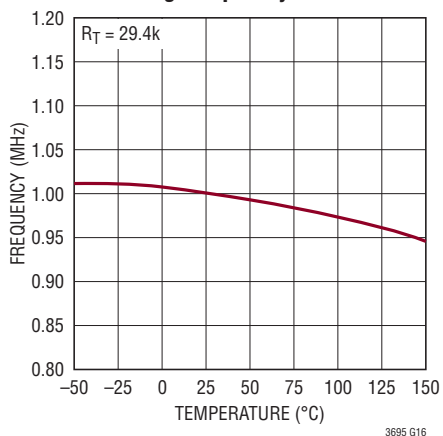

Frequency Foldback: LT3695

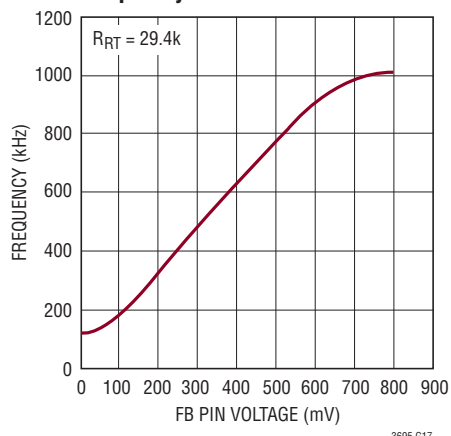

Frequency Foldback: LT3695-3.3

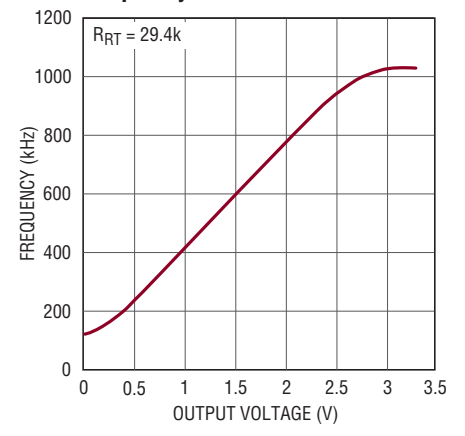

TYPICAL PERFORMANCE CHARACTERISTICS $T_A = 25^\circ\text{C}$, unless otherwise noted.

Frequency Foldback: LT3695-5

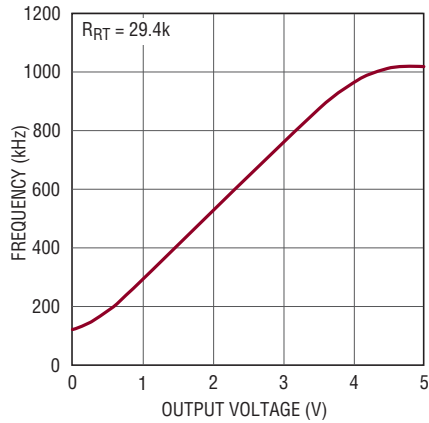

Minimum Switch On-Time

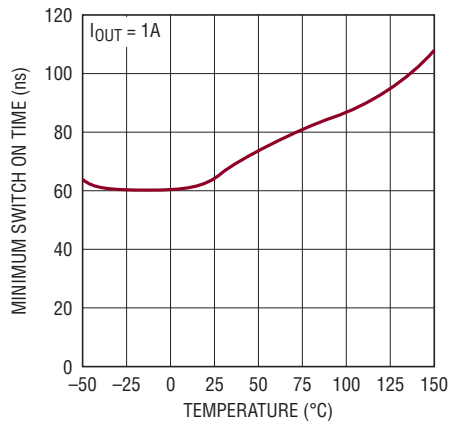

Soft-Start

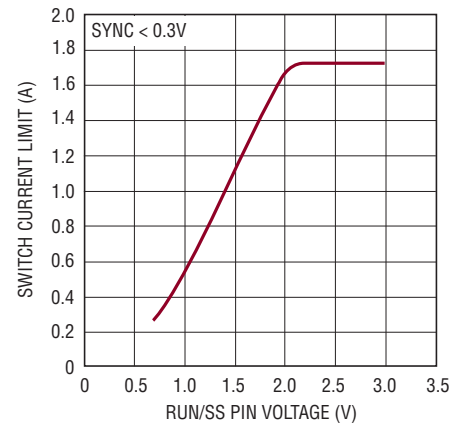

RUN/SS Pin Current

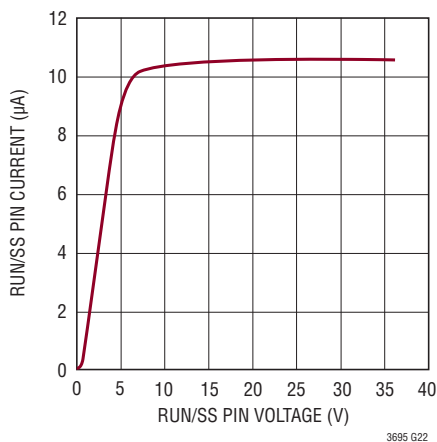

Boost Diode Forward Voltage

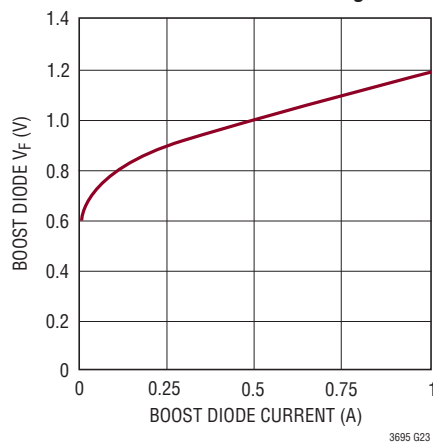

Error Amplifier Output Current: LT3695

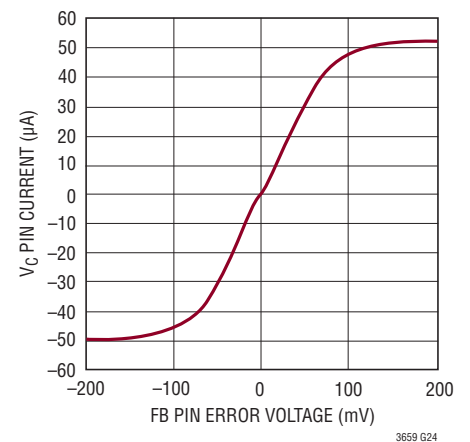

Error Amplifier Output Current: LT3695-3.3

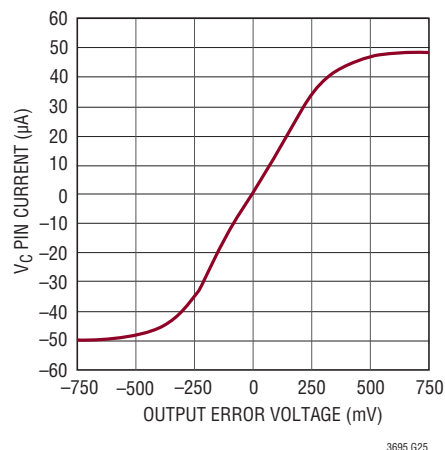

Error Amplifier Output Current: LT3695-5

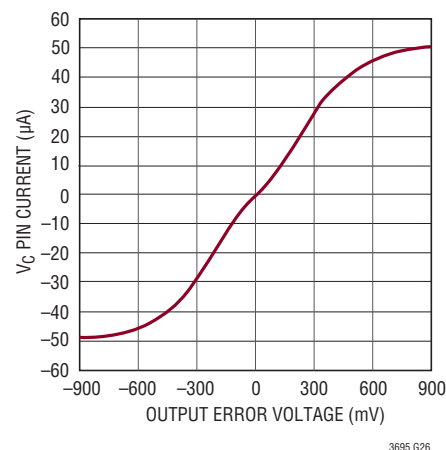

Minimum Input Voltage

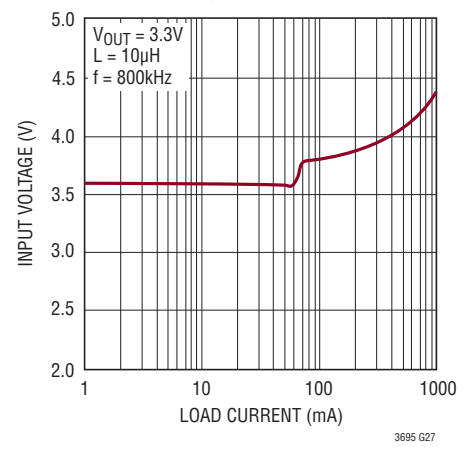

TYPICAL PERFORMANCE CHARACTERISTICS $T_A = 25^\circ\text{C}$, unless otherwise noted.

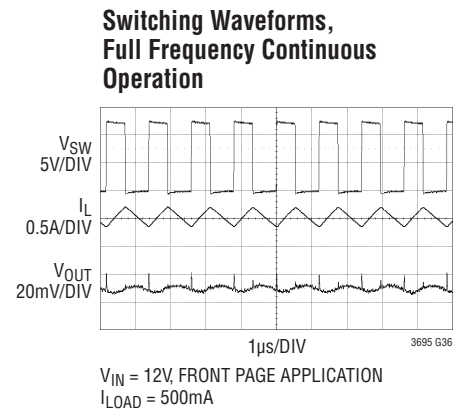
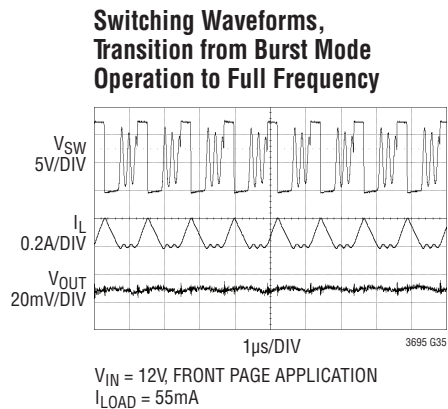
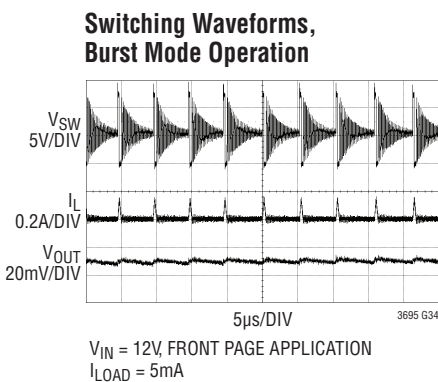
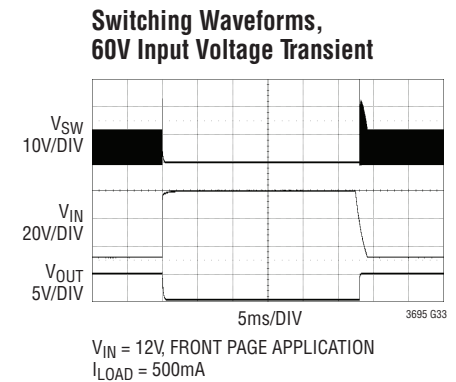
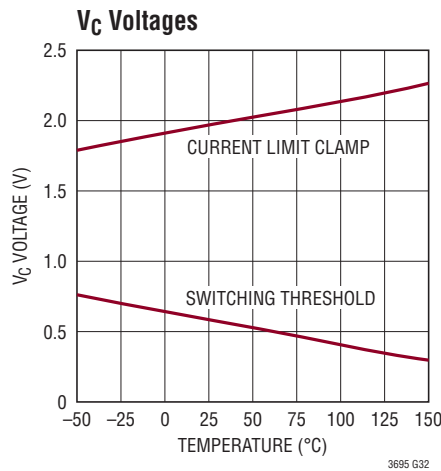
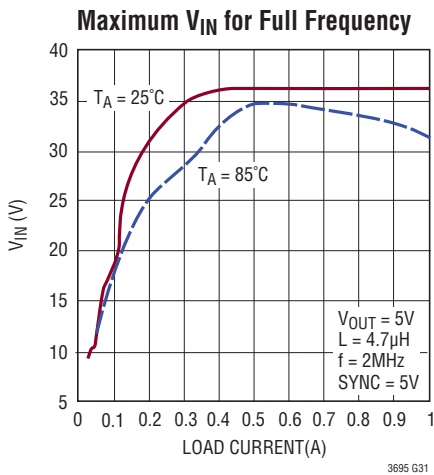
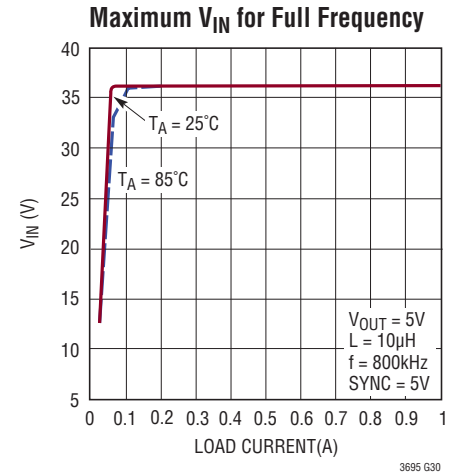
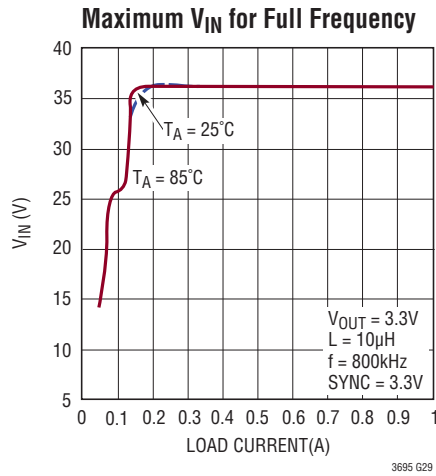
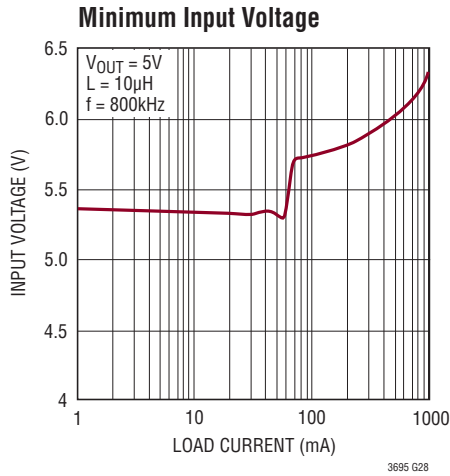

PIN FUNCTIONS (LT3695/LT3695-3.3, LT3695-5)

PGND (Pin 1, Exposed Pad Pin 17/Pin 1, Exposed Pad Pin 17): This is the power ground used by the catch diode (D1 in the Block Diagram) when its anode is connected to the DA pin. The exposed pad may be soldered to the PCB in order to lower the thermal resistance.

DA (Pin 2/Pin 2): Connect the anode of the catch diode (D1) to this pin. Internal circuitry senses the current through the catch diode providing frequency foldback in extreme situations.

NC (Pins 3, 10, 12/Pins 3, 10, 15): No Connects. These pins are not connected to internal circuitry and must be left floating to ensure fault tolerance.

SW (Pin 4/Pin 4): The SW pin is the output of the internal power switch. Connect this pin to the inductor, catch diode and boost capacitor.

RUN/SS (Pin 5/Pin 5): The RUN/SS pin is used to put the LT3695 regulators in shutdown mode. Tie to ground to shut down the LT3695 regulators. Tie to 2.5V or more for normal operation. RUN/SS also provides a soft-start function; see the Applications Information section for more information.

RT (Pin 6/Pin 6): Oscillator Resistor Input. Connect a resistor from this pin to ground to set the switching frequency.

SYNC (Pin 7/Pin 7): This is the external clock synchronization input. Ground this pin with a 100k resistor for low ripple Burst Mode operation at low output loads. Tie to 0.8V or more for pulse-skipping mode operation. Tie to a clock source for synchronization. Clock edges should have rise and fall times faster than 1 μ s. Note that the maximum load current depends on which mode is chosen. See the Applications Information section for more information.

V_{IN} (Pin 8/Pin 8): The V_{IN} pin supplies current to the internal regulator and to the internal power switch. This pin must be locally bypassed.

V_C (Pin 9/Pin 9): The V_C pin is the output of the internal error amplifier. The voltage on this pin controls the peak switch current. Tie an RC network from this pin to ground to compensate the control loop.

FB (Pin 11) LT3695: The LT3695 regulates the FB pin to 0.8V. Connect the feedback resistor divider tap to this pin.

PG (Pin 13/Pin 11): The PG pin is the open-collector output of an internal comparator. PG remains low until the FB pin (LT3695) or the OUT1,2 pins (LT3695-3.3, LT3695-5) are within 10% of the final regulation voltage. PG output is valid when V_{IN} is above the minimum input voltage and RUN/SS is high.

GND (Pin 14/Pin 12): The GND pin is the ground of all the internal circuitry. Tie directly to the local GND plane.

OUT1, OUT2, (Pins 14, 13) LT3695-3.3, LT3695-5: These pins connect to the anode of the boost Schottky diode and also supply current to the internal regulator. They also connect to the internal feedback resistors and must be connected to the output.

BD (Pin 15) LT3695: This pin connects to the anode of the boost Schottky diode and also supplies current to the LT3695's internal regulator.

BOOST (Pin 16/Pin 16): This pin is used to provide a drive voltage, higher than the input voltage, to the internal bipolar NPN power switch. Connect a capacitor (typically 0.22 μ F) between BOOST and SW.

BLOCK DIAGRAM

LT3695

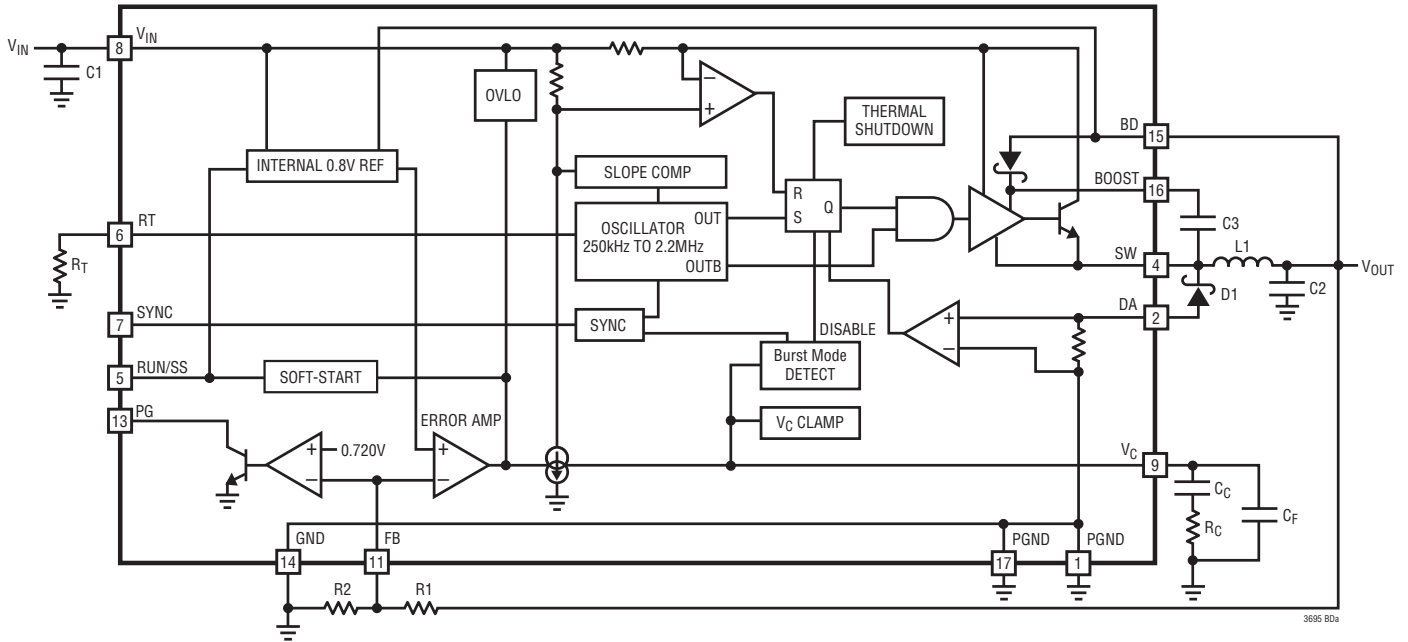

LT3695-3.3/LT3695-5

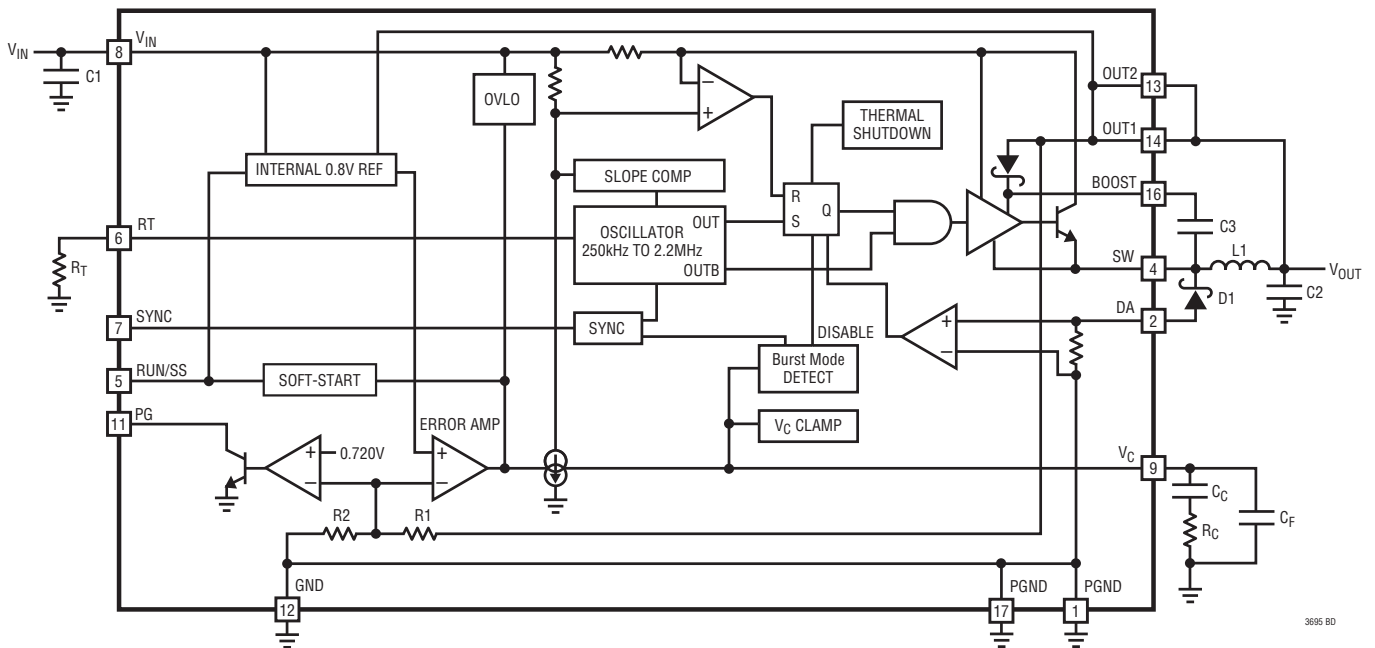

OPERATION

The LT3695 series are constant-frequency, current mode step-down regulators. An oscillator, with frequency set by R_T , enables an RS flip-flop, turning on the internal power switch. An amplifier and comparator monitor the current flowing between the V_{IN} and SW pins, turning the switch off when this current reaches a level determined by the voltage at V_C . An error amplifier measures the output voltage through an external resistor divider tied to the FB pin (LT3695) or through an internal resistor divider connected to the output voltage (LT3695-3.3, LT3695-5), and servos the V_C pin. If the error amplifier's output increases, more current is delivered to the output; if it decreases, less current is delivered. An active clamp on the V_C pin provides current limit. The V_C pin is also clamped to the voltage on the RUN/SS pin; soft-start is implemented by generating a voltage ramp at the RUN/SS pin using an external resistor and capacitor.

An internal regulator provides power to the control circuitry. The bias regulator normally draws power from the V_{IN} pin, but if the BD pin is connected to an external voltage higher than 3V (LT3695) or if the output voltage connected to the OUT1 and OUT2 pins exceeds 3V (LT3695-3.3, LT3695-5), bias power will be drawn from the external source. This improves efficiency. The RUN/SS pin is used to place the LT3695 regulators in shutdown, disconnecting the output and reducing the input current to less than 1 μ A.

The switch driver operates from either the input or from the BOOST pin. An external capacitor and the internal boost diode are used to generate a voltage at the BOOST pin that is higher than the input supply. This allows the driver to fully saturate the internal bipolar NPN power switch for efficient operation.

To further optimize efficiency, the LT3695 regulators automatically switch to Burst Mode operation in light load situations. Between bursts, all circuitry associated with controlling the output switch is shut down, reducing the input supply current to 75 μ A in a typical application.

The oscillator reduces the LT3695 regulators' operating frequency when the voltage at the FB pin (LT3695) or the OUT1,2 pins (LT3695-3.3, LT3695-5) is low. This frequency foldback helps to control the output current during start-up and overload conditions.

Internal circuitry monitors the current flowing through the catch diode via the DA pin and delays the generation of new switch pulses if this current is too high (above 1.6A nominal). This mechanism also protects the part during short-circuit and overload conditions by keeping the current through the inductor under control.

The LT3695 regulators contain a power good comparator which trips when the FB pin (LT3695) or the OUT1,2 pins (LT3695-3.3, LT3695-5) are at 90% of their regulated value. The PG output is an open-collector transistor that is off when the output is in regulation, allowing an external resistor to pull the PG pin high. Power good is valid when the LT3695 regulators are enabled and V_{IN} is above the minimum input voltage.

The LT3695 regulators have an overvoltage protection feature which disables switching action when V_{IN} goes above 38V (typical) during transients. The LT3695 regulators can then safely sustain transient input voltages up to 60V.

APPLICATIONS INFORMATION

FB Resistor Network (LT3695)

The output voltage of the LT3695 is programmed with a resistor divider between the output and the FB pin. Choose the resistor values according to:

$$R1 = R2 \left(\frac{V_{OUT}}{0.8V} - 1 \right)$$

Reference designators refer to the Block Diagram of the LT3695. 1% resistors are recommended to maintain output voltage accuracy.

Setting the Switching Frequency

The LT3695 regulators use a constant-frequency PWM architecture that can be programmed to switch from 250kHz to 2.2MHz by using a resistor tied from the RT pin to ground. A table showing the necessary R_T value for a desired switching frequency is in Table 1.

Table 1. Switching Frequency vs R_T Value

| SWITCHING FREQUENCY (MHz) | R_T VALUE (k Ω) |
|---------------------------|---------------------------|
| 0.25 | 158 |
| 0.3 | 127 |
| 0.4 | 90.9 |
| 0.5 | 71.5 |
| 0.6 | 57.6 |
| 0.7 | 47.5 |
| 0.8 | 40.2 |
| 0.9 | 34 |
| 1.0 | 29.4 |
| 1.2 | 22.6 |
| 1.4 | 18.2 |
| 1.6 | 14.7 |
| 1.8 | 12.1 |
| 2.0 | 9.76 |
| 2.2 | 8.06 |

Operating Frequency Trade-Offs

Selection of the operating frequency is a trade-off between efficiency, component size, minimum dropout voltage and maximum input voltage. The advantage of high frequency operation is that smaller inductor and capacitor values may be used. The disadvantages are lower efficiency, lower maximum input voltage and higher dropout voltage. The highest acceptable switching frequency ($f_{SW(MAX)}$) for a given application can be calculated as follows:

$$f_{SW(MAX)} = \frac{V_{OUT} + V_D}{t_{ON(MIN)}(V_{IN} - V_{SW} + V_D)}$$

where V_{IN} is the typical input voltage, V_{OUT} is the output voltage, V_D is the catch diode drop (~0.5V) and V_{SW} is the internal switch drop (~0.5V at max load). This equation shows that lower switching frequency is necessary to safely accommodate high V_{IN}/V_{OUT} ratio. Also, as shown in the Input Voltage Range section, lower frequency allows a lower dropout voltage. Input voltage range depends on the switching frequency because the LT3695 regulators' switch has finite minimum on and off times. An internal timer forces the switch to be off for at least $t_{OFF(MIN)}$ per cycle; this timer has a maximum value of 210ns (250ns for $T_J > 125^\circ\text{C}$). On the other hand, delays associated with turning off the power switch dictate the minimum on-time, $t_{ON(MIN)}$, before the switch can be turned off; $t_{ON(MIN)}$ has a maximum value of 150ns over temperature. The minimum and maximum duty cycles that can be achieved taking minimum on and off times into account are:

$$DC_{MIN} = f_{SW} t_{ON(MIN)}$$

$$DC_{MAX} = 1 - f_{SW} t_{OFF(MIN)}$$

where f_{SW} is the switching frequency, $t_{ON(MIN)}$ is the minimum switch on time (150ns), and $t_{OFF(MIN)}$ is the minimum switch off time (210ns, 250ns for $T_J > 125^\circ\text{C}$). These equations show that the duty cycle range increases when the switching frequency is decreased.

APPLICATIONS INFORMATION

A good choice of switching frequency should allow an adequate input voltage range (see Input Voltage Range section) and keep the inductor and capacitor values small.

Input Voltage Range

The minimum input voltage is determined by either the LT3695 regulators' minimum operating voltage of ~3.6V ($V_{BD} > 3V$) or by their maximum duty cycle (see equation in Operating Frequency Trade-Offs section). The minimum input voltage due to duty cycle is:

$$V_{IN(MIN)} = \frac{V_{OUT} + V_D}{1 - f_{SW} t_{OFF(MIN)}} - V_D + V_{SW}$$

where $V_{IN(MIN)}$ is the minimum input voltage, and $t_{OFF(MIN)}$ is the minimum switch off time. Note that a higher switching frequency will increase the minimum input voltage. If a lower dropout voltage is desired, a lower switching frequency should be used.

The maximum input voltage for LT3695 regulator applications depends on switching frequency, the absolute maximum ratings of the V_{IN} and BOOST pins and the operating mode. The LT3695 regulators can operate from continuous input voltages up to 36V. Input voltage transients of up to 60V are also safely withstood. However, note that while $V_{IN} > V_{OVLO}$ (overvoltage lockout, 38V typical), the LT3695 regulators will stop switching, allowing the output to fall out of regulation.

For a given application where the switching frequency and the output voltage are already fixed, the maximum input voltage that guarantees optimum output voltage ripple for that application can be found by applying the following expression:

$$V_{IN(MAX)} = \frac{V_{OUT} + V_D}{f_{SW} t_{ON(MIN)}} - V_D + V_{SW}$$

where $V_{IN(MAX)}$ is the maximum operating input voltage, V_{OUT} is the output voltage, V_D is the catch diode drop (~0.5V), V_{SW} is the internal switch drop (~0.5V at max load), f_{SW} is the switching frequency (set by R_T) and $t_{ON(MIN)}$ is the minimum switch on time (~150ns). Note that a higher switching frequency will reduce the maximum operating

input voltage. Conversely, a lower switching frequency will be necessary to achieve optimum operation at high input voltages.

Special attention must be paid when the output is in start-up, short-circuit or other overload conditions. During these events, the inductor peak current might easily reach and even exceed the maximum current limit of the LT3695 regulators, especially in those cases where the switch already operates at minimum on-time. The circuitry monitoring the current through the catch diode via the DA pin prevents the switch from turning on again if the inductor valley current is above 1.6A nominal. In these cases, the inductor peak current is therefore the maximum current limit of the LT3695 regulators plus the additional current overshoot during the turn off delay due to minimum on time:

$$I_{L(PEAK)} = 2A + \frac{V_{IN(MAX)} - V_{OUT(OL)}}{L} \cdot t_{ON(MIN)}$$

where $I_{L(PEAK)}$ is the peak inductor current, $V_{IN(MAX)}$ is the maximum expected input voltage, L is the inductor value, $t_{ON(MIN)}$ is the minimum on time and $V_{OUT(OL)}$ is the output voltage under the overload condition. The parts are robust enough to survive prolonged operation under these conditions as long as the peak inductor current does not exceed 3.5A. Inductor current saturation and excessive junction temperature may further limit performance.

Input voltage transients of up to V_{OVLO} are acceptable regardless of the switching frequency. In this case, the LT3695 regulators may enter pulse-skipping operation where some switching pulses are skipped to maintain output regulation. In this mode the output voltage ripple and inductor current ripple will be higher than in normal operation.

Input voltage transients above V_{OVLO} and up to 60V can be tolerated. However, since the parts will stop switching during these transients, the output will fall out of regulation and the output capacitor may eventually be completely discharged. This case must be treated then as a start-up condition as soon as V_{IN} returns to values below V_{OVLO} and the part starts switching again.

APPLICATIONS INFORMATION

Inductor Selection and Maximum Output Current

A good first choice for the inductor value is:

$$L = (V_{OUT} + V_D) \cdot \frac{1.8}{f_{SW}}$$

where f_{SW} is the switching frequency in MHz, V_{OUT} is the output voltage, V_D is the catch diode drop (~0.5V) and L is the inductor value in μH .

The inductor's RMS current rating must be greater than the maximum load current and its saturation current should be about 30% higher. To keep the efficiency high, the series resistance (DCR) should be less than 0.1Ω , and the core material should be intended for high frequency applications. Table 2 lists several vendors and suitable types.

For robust operation in fault conditions (start-up or short-circuit) and high input voltage (>30V), the saturation current should be chosen high enough to ensure that the inductor peak current does not exceed 3.5A. For example, an application running from an input voltage of 36V using a $10\mu\text{H}$ inductor with a saturation current of 2.5A will tolerate the mentioned fault conditions.

The optimum inductor for a given application may differ from the one indicated by this simple design guide. A larger value inductor provides a higher maximum load current and reduces the output voltage ripple. If your load is lower than the maximum load current, then you can relax the value of the inductor and operate with higher ripple current. This allows you to use a physically smaller inductor, or one with a lower DCR resulting in higher efficiency. Be aware that if the inductance differs from the simple rule above, then the maximum load current will depend on input voltage. In addition, low inductance may result in discontinuous mode operation, which further reduces maximum load current. For details of maximum output current and discontinuous mode operation, see Linear Technology's Application Note 44. Finally, for duty cycles greater than 50% ($V_{OUT}/V_{IN} > 0.5$), a minimum inductance is required to avoid sub-harmonic oscillations:

$$L_{MIN} = (V_{OUT} + V_D) \cdot \frac{1.2}{f_{SW}}$$

The current in the inductor is a triangle wave with an average value equal to the load current. The peak inductor and switch current is:

$$I_{SW(PEAK)} = I_{L(PEAK)} = I_{OUT(MAX)} + \frac{\Delta I_L}{2}$$

where $I_{L(PEAK)}$ is the peak inductor current, $I_{OUT(MAX)}$ is the maximum output load current and ΔI_L is the inductor ripple current. The LT3695 regulators limit their switch current in order to protect themselves and the system from overload faults. Therefore, the maximum output current that the LT3695 regulators will deliver depends on the switch current limit, the inductor value and the input and output voltages.

When the switch is off, the potential across the inductor is the output voltage plus the catch diode drop. This gives the peak-to-peak ripple current in the inductor:

$$\Delta I_L = \frac{(1-DC) \cdot (V_{OUT} + V_D)}{L \cdot f_{SW}}$$

where f_{SW} is the switching frequency of the LT3695 regulators, DC is the duty cycle and L is the value of the inductor.

To maintain output regulation, the inductor peak current must be less than the LT3695 regulators' switch current limit, I_{LIM} . If the SYNC pin is grounded, I_{LIM} is at least 1.45A at low duty cycles and decreases to 1.1A at DC = 90%. If the SYNC pin is tied to 0.8V or more or if it is tied to a clock source for synchronization, I_{LIM} is at least 1.18A at low duty cycles and decreases to 0.85A at DC = 90%. The maximum output current is also a function of the chosen inductor value and can be approximated by the following expressions depending on the SYNC pin configuration:

For the SYNC pin grounded:

$$I_{OUT(MAX)} = I_{LIM} - \frac{\Delta I_L}{2} = 1.45\text{A} \cdot (1 - 0.24 \cdot DC) - \frac{\Delta I_L}{2}$$

For the SYNC pin tied to 0.8V or more, or tied to a clock source for synchronization:

$$I_{OUT(MAX)} = I_{LIM} - \frac{\Delta I_L}{2} = 1.18\text{A} \cdot (1 - 0.29 \cdot DC) - \frac{\Delta I_L}{2}$$

APPLICATIONS INFORMATION

Choosing an inductor value so that the ripple current is small will allow a maximum output current near the switch current limit.

Table 2. Inductor Vendors

| VENDOR | URL | PART SERIES | TYPE |
|-----------|----------------------|------------------------------------|--|
| Murata | www.murata.com | LQH55D | Open |
| Tdk | www.componenttdk.com | SLF7045 SLF10145 | Shielded Shielded |
| Toko | www.toko.com | D62CB D63CB D73C D75F | Shielded Shielded Shielded Open |
| Coilcraft | www.coilcraft.com | MSS7341 MSS1038 | Shielded Shielded |
| Sumida | www.sumida.com | CR54 CDRH74 CDRH6D38 CR75 | Open Shielded Shielded Open |

One approach to choosing the inductor is to start with the simple rule given above, look at the available inductors, and choose one to meet cost or space goals. Then use these equations to check that the LT3695 regulators will be able to deliver the required output current. Note again that these equations assume that the inductor current is continuous. Discontinuous operation occurs when I_{OUT} is less than $\Delta I_L/2$.

Input Capacitor

Bypass the input of the LT3695 regulators' circuit with a ceramic capacitor of X7R or X5R type. Y5V types have poor performance over temperature and applied voltage, and should not be used. A 2.2 μ F to 10 μ F ceramic capacitor is adequate to bypass the LT3695 regulators and will easily handle the ripple current. Note that larger input capacitance is required when a lower switching frequency is used. If the input power source has high impedance, or there is significant inductance due to long wires or cables, additional bulk capacitance may be necessary. This can be provided with a lower performance electrolytic capacitor.

Step-down regulators draw current from the input supply in pulses with very fast rise and fall times. The input capacitor is required to reduce the resulting voltage ripple at the LT3695 regulators and to force this very high frequency switching current into a tight local loop, minimizing

EMI. A 2.2 μ F capacitor is capable of this task, but only if it is placed close to the LT3695 regulators (see the PCB Layout section for more information). A second precaution regarding the ceramic input capacitor concerns the maximum input voltage rating of the LT3695 regulators. A ceramic input capacitor combined with trace or cable inductance forms a high-Q (underdamped) tank circuit. If the LT3695 regulators circuit is plugged into a live supply, the input voltage can ring to twice its nominal value, possibly exceeding the LT3695 regulators' voltage rating. For details see Application Note 88.

Output Capacitor and Output Ripple

The output capacitor has two essential functions. Along with the inductor, it filters the square wave generated by the LT3695 regulators to produce the DC output. In this role it determines the output ripple, and low impedance at the switching frequency is important. The second function is to store energy in order to satisfy transient loads and stabilize the LT3695 regulators' control loop. Ceramic capacitors have very low equivalent series resistance (ESR) and provide the best ripple performance. A good starting value is:

$$C_{OUT} = \frac{50}{V_{OUT}} f_{SW}$$

where f_{SW} is in MHz, and C_{OUT} is the recommended output capacitance in μ F. Use X5R or X7R types. This choice will provide low output ripple and good transient response. Transient performance can be improved with a higher value capacitor if the compensation network is also adjusted to maintain the loop bandwidth. A lower value of output capacitor can be used to save space and cost but transient performance will suffer. See the Frequency Compensation section to choose an appropriate compensation network.

When choosing a capacitor, look carefully through the data sheet to find out what the actual capacitance is under operating conditions (applied voltage and temperature). A physically larger capacitor, or one with a higher voltage rating, may be required. High performance tantalum or electrolytic capacitors can be used for the output capacitor.

APPLICATIONS INFORMATION

Table 3. Capacitor Vendors

| VENDOR | PHONE | URL | PART SERIES | COMMANDS |
|-------------|----------------|---------------------|----------------------------|------------|
| Panasonic | (714) 373-7366 | www.panasonic.com | Ceramic, Polymer, Tantalum | EEF Series |
| Kemet | (864) 963-6300 | www.kemet.com | Ceramic, Tantalum | T494, T495 |
| Sanyo | (408) 749-9714 | www.sanyovideo.com | Ceramic, Polymer, Tantalum | POSCAP |
| Murata | (408) 436-1300 | www.murata.com | Ceramic | |
| AVX | | www.avxcorp.com | Ceramic, Tantalum | TPS Series |
| Taiyo Yuden | (864) 963-6300 | www.taiyo-yuden.com | Ceramic | |

Low ESR is important, so choose one that is intended for use in switching regulators. The ESR should be specified by the supplier, and should be 0.05Ω or less. Such a capacitor will be larger than a ceramic capacitor and will have a larger capacitance, because the capacitor must be large to achieve low ESR. Table 3 lists several capacitor vendors.

Diode Selection

The catch diode (D1 from Block Diagram) conducts current only during switch off time. Average forward current in normal operation can be calculated from:

$$I_{D(AVG)} = I_{OUT} \cdot (1 - DC)$$

where DC is the duty cycle. The only reason to consider a diode with larger current rating than necessary for nominal operation is for the case of shorted or overloaded output conditions. For the worst case of shorted output the diode average current will then increase to a value that depends on the following internal parameters: switch current limit, catch diode (DA pin) current threshold and minimum on-time. The worst case (taking maximum values for the above mentioned parameters) is given by the following expression:

$$I_{D(AVG)MAX} = 2A + \frac{1}{2} \cdot \frac{V_{IN}}{L} \cdot 150ns$$

Peak reverse voltage is equal to the regulator input voltage if it is below the overvoltage protection threshold. This feature keeps the switch off for $V_{IN} > V_{OVLO}$ (39.9V maximum). For inputs up to the maximum operating voltage of 36V, use a diode with a reverse voltage rating greater

Table 4. Schottky Diodes

| PART NUMBER | V _R (V) | I _{AVE} (A) | V _F at 1A (mV) | V _F at 2A (mV) |
|------------------------------|--------------------|----------------------|---------------------------|---------------------------|
| On-Semiconductor | | | | |
| MBR0520L | 20 | 0.5 | | |
| MBR0540 | 40 | 0.5 | 620 | |
| MBRM120E | 20 | 1 | 530 | 595 |
| MBRM140 | 40 | 1 | 550 | |
| Diodes Inc. | | | | |
| B0530W | 30 | 0.5 | | |
| B0540W | 40 | 0.5 | 620 | |
| B120 | 20 | 1 | 500 | |
| B130 | 30 | 1 | 500 | |
| B140 | 40 | 1 | 500 | |
| B220 | 20 | 2 | | 500 |
| B230 | 30 | 2 | | 500 |
| B140HB | 40 | 1 | 530 | |
| DFLS240L | 40 | 2 | | 500 |
| DFLS140 | 40 | 1.1 | 510 | |
| B240 | 40 | 2 | | 500 |
| Central Semiconductor | | | | |
| CMSH1-40M | 40 | 1 | 500 | |
| CMSH1-40ML | 40 | 1 | 400 | |
| CMSH2-40M | 40 | 2 | | 550 |
| CMSH2-40L | 40 | 2 | | 400 |
| CMSH2-40 | 40 | 2 | | 500 |

than the input voltage. If transients at the input of up to 60V are expected, use a diode with a reverse voltage rating of 40V. Table 4 lists several Schottky diodes and their manufacturers. If operating at high ambient temperatures, consider using a Schottky with low reverse leakage.

APPLICATIONS INFORMATION

Audible Noise

Ceramic capacitors are small, robust and have very low ESR. However, ceramic capacitors can sometimes cause problems when used with the LT3695 regulators due to their piezoelectric nature. When in Burst Mode operation, the LT3695 regulators' switching frequency depends on the load current, and at very light loads the LT3695 regulators can excite the ceramic capacitor at audio frequencies, generating audible noise. Since the LT3695 regulators operate at a lower current limit during Burst Mode operation, the noise is typically very quiet. If this is unacceptable, use a high performance tantalum or electrolytic capacitor at the output.

Frequency Compensation

The LT3695 regulators use current mode control to regulate the output. This simplifies loop compensation. In particular, the LT3695 regulators do not require the ESR of the output capacitor for stability, so you are free to use ceramic capacitors to achieve low output ripple and small circuit size. Frequency compensation is provided by the components tied to the V_C pin, as shown in Figure 1. Generally a capacitor (C_C) and a resistor (R_C) in series to ground are used. In addition, there may be a lower value capacitor in parallel. This capacitor (C_F) is used to filter noise at the switching frequency, and is required only if a phase-lead capacitor (C_{PL} , LT3695 only) is used or if the output capacitor has high ESR.

Loop compensation determines the stability and transient performance. Optimizing the design of the compensation network depends on the application and type of output capacitor. A practical approach is to start with one of the circuits in this data sheet that is similar to your application and tune the compensation network to optimize the performance. Stability should then be checked across all operating conditions, including load current, input voltage and temperature. The LT1375 data sheet contains a more thorough discussion of loop compensation and describes how to test the stability using a transient load. Figure 1 shows an equivalent circuit for the LT3695 regulators control loop. The error amplifier is a transconductance amplifier with finite output impedance. The power section, consisting of the modulator, power switch and inductor, is modeled as a transconductance amplifier generating an output current proportional to the voltage at the V_C pin. Note that the output capacitor integrates this current, and that the capacitor on the V_C pin (C_C) integrates the error amplifier output current, resulting in two poles in the loop. In most cases a zero is required and comes from either the output capacitor ESR or from a resistor R_C in series with C_C . This simple model works well as long as the value of the inductor is not too high and the loop crossover frequency is much lower than the switching frequency. A phase lead capacitor (C_{PL} , LT3695 only) across the feedback divider may improve the transient response. Figure 2 shows the transient response when the load current is stepped from 300mA to 650mA and back to 300mA.

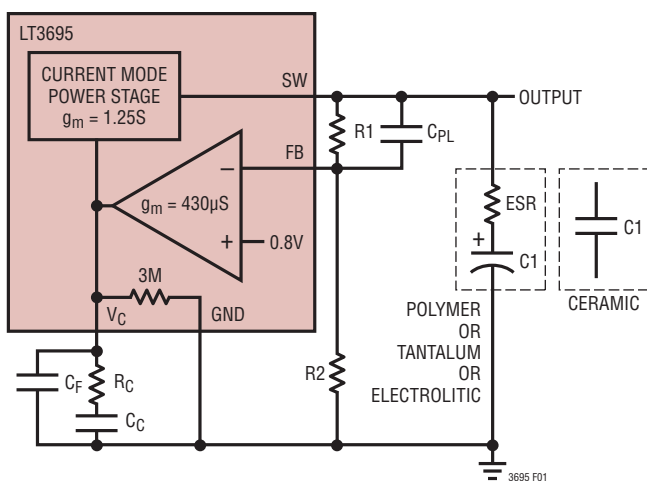

Figure 1. Model for Loop Response. Note That R1 and R2 Are Integrated in the LT3695-3.3 and LT3695-5

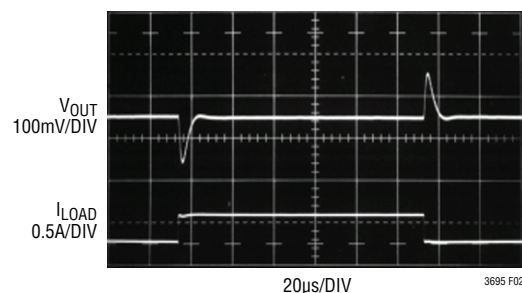

Figure 2. Transient Load Response of the LT3695 Regulators. A 3.3V_{OUT} Typical Application with V_{IN} = 12V as the Load Current Is Stepped from 300mA to 650mA

APPLICATIONS INFORMATION

Low Ripple Burst Mode Operation

The LT3695 regulators are capable of operating in either low ripple Burst Mode operation or pulse-skipping mode which are selected using the SYNC pin. See the Synchronization section for more information.

To enhance efficiency at light loads, the LT3695 regulators can be operated in low ripple Burst Mode operation which keeps the output capacitor charged to the proper voltage while minimizing the input quiescent current. During Burst Mode operation, the LT3695 regulators deliver single cycle bursts of current to the output capacitor followed by sleep periods where the output power is delivered to the load by the output capacitor. Because the LT3695 regulators deliver power to the output with single, low current pulses, the output ripple is kept below 15mV for a typical application. In addition, V_{IN} and BD (LT3695), and OUT1,2 (LT3695-3.3, LT3695-5) quiescent currents are reduced to typically 35 μ A, 55 μ A and 65 μ A, respectively, during the sleep time. As the load current decreases towards a no-load condition, the percentage of time that the LT3695 regulators operate in sleep mode increases and the average input current is greatly reduced resulting in high efficiency even at very low loads (see Figure 3). At higher output loads (above about 70mA for the front page application) the LT3695 regulators will be running at the frequency programmed by the R_T resistor, and will be operating in standard PWM mode. The transition between PWM and low ripple Burst Mode operation is seamless, and will not disturb the output voltage.

If low quiescent current is not required, tie SYNC high to select pulse-skipping mode. The benefit of this mode is that the LT3695 regulators will enter full frequency standard

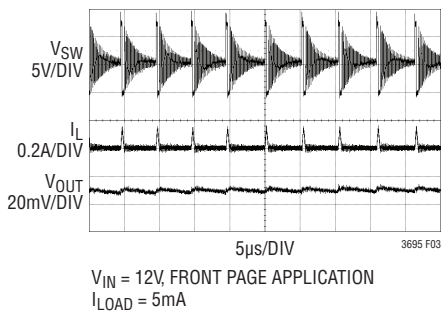

Figure 3. Switching Waveforms, Burst Mode Operation

PWM operation at a lower output load current than when in Burst Mode operation. With the SYNC pin tied low, the front page application circuit will switch at full frequency at output loads higher than about 100mA. With the SYNC pin tied high, the front page application circuit will switch at full frequency at output loads higher than about 30mA. The maximum load current that the LT3695 regulators can supply is reduced when SYNC is high.

BOOST Pin Considerations

Capacitor C3 and the internal boost Schottky diode (see the Block Diagram) are used to generate a boost voltage that is higher than the input voltage. In most cases a 0.22 μ F capacitor will work well. Figure 4 shows three ways to arrange the boost circuit for the LT3695 regulators. The BOOST pin must be more than 2.3V above the SW pin for best efficiency. For outputs of between 3V and 8V, the standard circuit (Figure 4a) is best. For outputs between 2.8V and 3V, use a 1 μ F boost capacitor. A 2.5V output presents a special case because it is marginally adequate to support the boosted drive stage while using the internal boost diode. For reliable BOOST pin operation with 2.5V outputs use a good external Schottky diode (such as the ON Semi MBR0540), and a 1 μ F boost capacitor (see Figure 4b). For lower output voltages the boost diode can be tied to the input (Figure 4c), or to another supply greater than 2.8V. Keep in mind that a minimum input voltage of 4.3V is required if the voltage at the BD pin is smaller than 3V. Tying BD to V_{IN} reduces the maximum input voltage to 25V. The circuit in Figure 4a is more efficient because the BOOST pin current and BD pin quiescent current come from a lower voltage source. You must also be sure that the maximum voltage ratings of the BOOST and BD pins are not exceeded.

As mentioned, a minimum of 2.5V across the BOOST capacitor is required for proper operation of the internal BOOST circuitry to provide the base current for the power NPN switch. For BD pin voltages higher than 3V, the excess voltage across the BOOST capacitor does not bring an increase in performance but dissipates additional power in the internal BOOST circuitry instead. The BOOST circuitry tolerates reasonable amounts of power, however excessive power dissipation on this circuitry may impair reliability. For reliable operation, use no more than 8V on the BD pin for

3695fa

APPLICATIONS INFORMATION

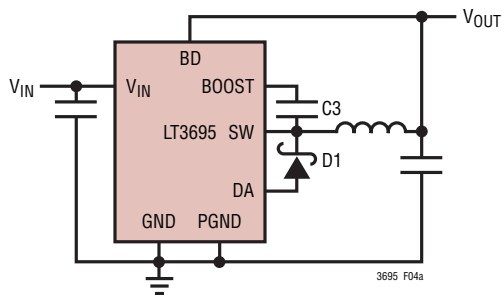

(4a) For $V_{OUT} > 2.8V$, $V_{IN(MIN)} = 4.3V$ if $V_{OUT} < 3V$

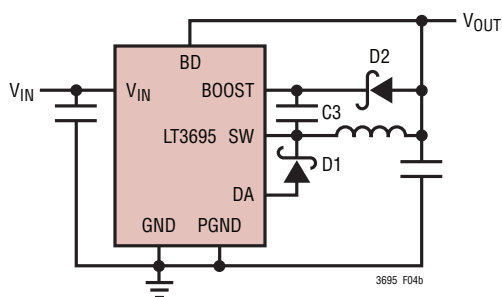

(4b) For $2.5V < V_{OUT} < 2.8V$, $V_{IN(MIN)} = 4.3V$

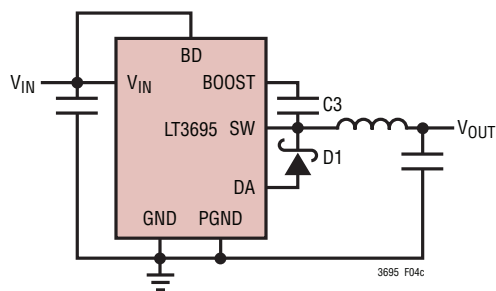

(4c) For $V_{OUT} < 2.5V$, $V_{IN(MAX)} = 25V$

Figure 4. Three Circuits for Generating the Boost Voltage for the LT3695

the circuit in Figure 4a. For higher output voltages, make sure that there is no more than 8V at the BD pin either by connecting it to another available supply higher than 3V or by using a Zener diode between V_{OUT} and BD to maintain the BD pin voltage between 3V and 8V.

The minimum operating voltage of the LT3695 regulators application is limited by the minimum input voltage and by the maximum duty cycle as outlined previously. For proper start-up, the minimum input voltage is also limited by the boost circuit. If the input voltage is ramped slowly, or the LT3695 regulators are turned on with their RUN/SS pin when

the output is already in regulation, then the boost capacitor may not be fully charged. Because the boost capacitor is charged with the energy stored in the inductor, the circuit will rely on some minimum load current to get the boost circuit running properly. This minimum load will depend on input and output voltages, and on the arrangement of the boost circuit. The minimum load generally goes to zero once the circuit has started. Figure 5 shows a plot of minimum load to start and to run as a function of input voltage. In many cases the discharged output capacitor will present a load to the switcher, which will allow it to start. The plots show the worst-case situation where V_{IN} is ramping very slowly. For lower start-up voltage, the boost diode can be tied to V_{IN} ; however, this restricts the input range to one-half of the absolute maximum rating of the BOOST pin. At light loads, the inductor current becomes discontinuous and the effective duty cycle can be very high.

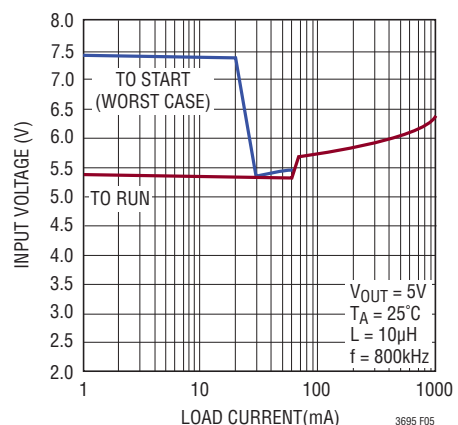
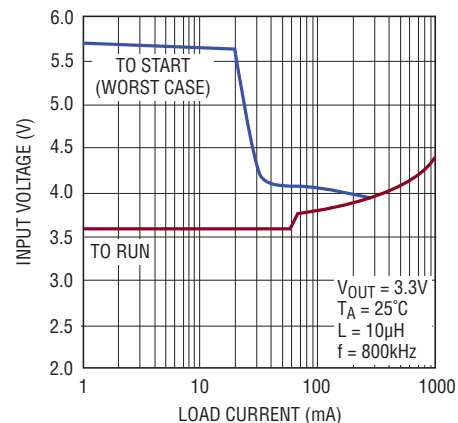

Figure 5. The Minimum Input Voltage Depends on Output Voltage, Load Current and Boost Circuit

APPLICATIONS INFORMATION

This reduces the minimum input voltage to approximately 300mV above V_{OUT} . At higher load currents, the inductor current is continuous and the duty cycle is limited by the maximum duty cycle of the LT3695 regulators, requiring a higher input voltage to maintain regulation.

Soft-Start

The RUN/SS pin can be used to soft-start the LT3695 regulators, reducing the maximum input current during start-up. The RUN/SS pin is driven through an external RC network to create a voltage ramp at this pin. Figure 6 shows the start-up and shutdown waveforms with the soft-start circuit. By choosing a large RC time constant, the peak start-up current can be reduced to the current that is required to regulate the output, with no overshoot. Choose the value of the resistor so that it can supply 7.5 μ A when the RUN/SS pin reaches 2.5V. For fault tolerant applications, see the discussion of the RUN/SS resistor in the Fault Tolerance section.

Synchronization

To select low ripple Burst Mode operation, tie the SYNC pin below 0.3V (this can be ground or a logic output).

Synchronizing the oscillator of the LT3695 regulators to an external frequency can be done by connecting a square wave (with 20% to 80% duty cycle) to the SYNC pin. The square wave amplitude should have valleys that are below 0.3V and peaks that are above 0.8V (up to 6V).

The LT3695 regulators will not enter Burst Mode operation at low output loads while synchronized to an external clock, but instead will skip pulses to maintain regulation.

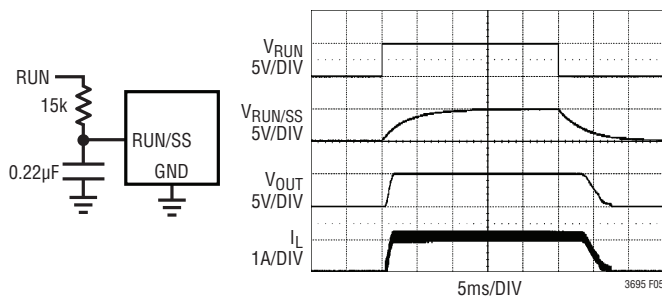

Figure 6. To Soft-Start the LT3695 Regulators, Add a Resistor and Capacitor to the RUN/SS Pin

The maximum load current that the part can supply is reduced when a clock signal is applied to SYNC.

The LT3695 regulators may be synchronized over a 300kHz to 2.2MHz range. The R_T resistor should be chosen to set the LT3695 regulators switching frequency 20% below the lowest synchronization input. For example, if the synchronization signal is 360kHz, the R_T should be chosen for 300kHz. To assure reliable and safe operation the LT3695 regulators will only synchronize when the output voltage is near regulation as indicated by the PG flag. It is therefore necessary to choose a large enough inductor value to supply the required output current at the frequency set by the R_T resistor. See the Inductor Selection section for more information. It is also important to note that slope compensation is set by the R_T value; to avoid subharmonic oscillations, calculate the minimum inductor value using the frequency determined by R_T .

Shorted and Reversed Input Protection

If the inductor is chosen so that it will not saturate excessively, the LT3695 regulators will tolerate a shorted output. When operating in short-circuit condition, the LT3695 regulators will reduce their frequency until the valley current is at a typical value of 1.6A (see Figure 7). There is another situation to consider in systems where the output will be held high when the input to the LT3695 regulators is absent. This may occur in battery charging applications or in battery backup systems where a battery or some other supply is diode ORed with the LT3695 regulators' output. If the V_{IN} pin is allowed to float and the RUN/SS pin is held high (either by a logic signal or because it is tied to V_{IN}),

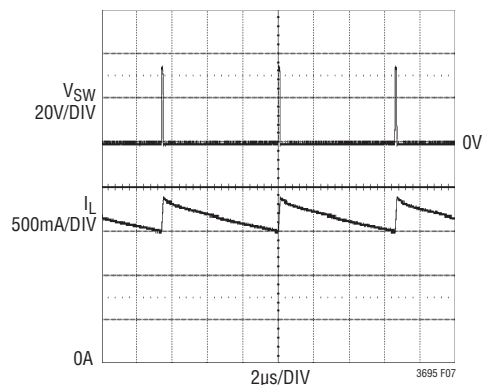

Figure 7. The LT3695 Regulators Reduce Their Frequency to Protect Against Shorted Output with 36V Input

APPLICATIONS INFORMATION

then the LT3695 regulators' internal circuitry will pull its quiescent current through its SW pin. This is fine if your system can tolerate a few mA in this state. If you ground the RUN/SS pin, the SW pin current will drop to essentially zero. However, if the V_{IN} pin is grounded while the output is held high, then parasitic diodes inside the LT3695 regulators can pull large currents from the output through the SW pin and the V_{IN} pin. Figure 8 shows a circuit that will run only when the input voltage is present and that protects against a shorted or reversed input.

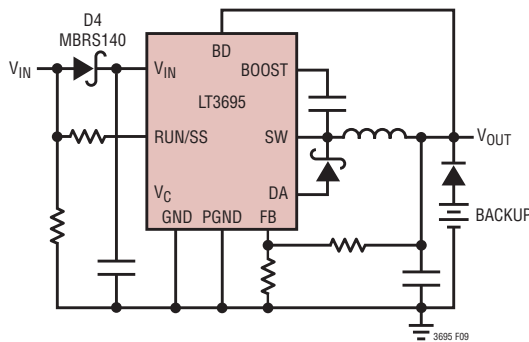

Figure 8. Diode D4 Prevents a Shorted Input from Discharging a Backup Battery Tied to the Output. It Also Protects the Circuit from a Reversed Input. The Regulator Runs Only When the Input Is Present

PCB Layout

For proper operation and minimum EMI, care must be taken during printed circuit board layout. Figures 9 and 10 show the recommended component placement with trace, ground plane and via locations. Note that large, switched currents flow in the LT3695 regulators' V_{IN} , SW and PGND pins, the catch diode and the input capacitor (C_{IN}). The loop formed by these components should be as small as possible. These components, along with the inductor and output capacitor (C_{OUT}), should be placed on the same side of the circuit board, and their connections should be made on that layer. All connections to GND should be made at a common star ground point or directly to a local, unbroken ground plane below these components. The SW and BOOST nodes should be laid out carefully to avoid interference. Finally, keep the FB, R_T and V_C nodes small so that the ground traces will shield them from the SW and BOOST nodes. To keep thermal resistance low, extend the ground plane as much as possible and add thermal vias under and near the LT3695 regulators to any additional ground planes within the circuit board and on the bottom side. Keep in mind that the thermal design must keep the junctions of the IC below the specified absolute maximum temperature.

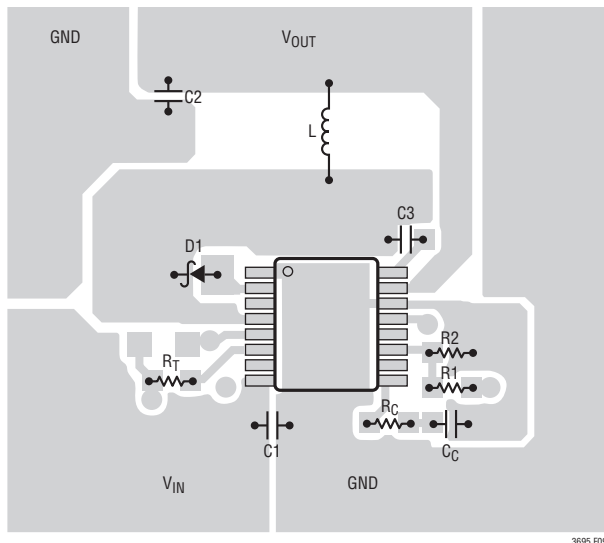

Figure 9. A Good PCB Layout Ensures Proper, Low EMI Operation (LT3695)

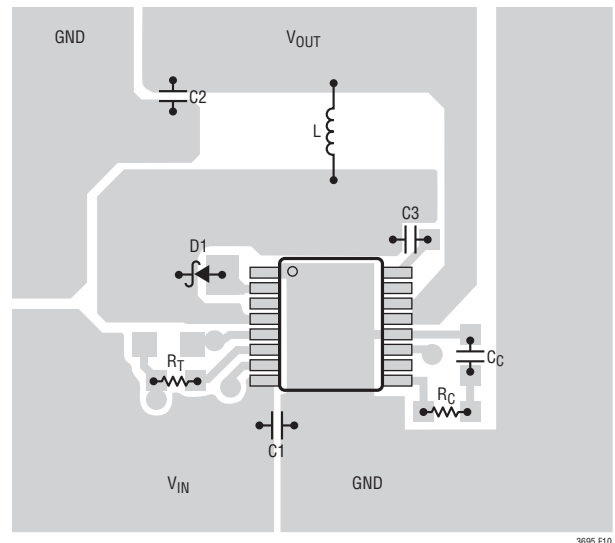

Figure 10. A Good PCB Layout Ensures Proper, Low EMI Operation (LT3695-3.3, LT3695-5)

APPLICATIONS INFORMATION

High Temperature Considerations

The PCB must provide heat sinking to keep the LT3695 regulators cool. The exposed pad on the bottom of the package may be soldered to a copper area which should be tied to large copper layers below with thermal vias; these layers will spread the heat dissipated by the LT3695 regulators. Place additional vias to reduce thermal resistance further. With these steps, the thermal resistance from die (or junction) to ambient can be reduced to $\theta_{JA} = 40^{\circ}\text{C}/\text{W}$ or less. With 100 LFPM airflow, this resistance can fall by another 25%. Further increases in airflow will lead to lower thermal resistance. Because of the large output current capability of the LT3695 regulators, it is possible to dissipate enough heat to raise the junction temperature beyond the absolute maximum. When operating at high ambient temperatures, the maximum load current should be derated as the ambient temperature approaches these maximums. If the junction temperature reaches the thermal shutdown threshold, the parts will stop switching to prevent internal damage due to overheating.

Power dissipation within the LT3695 regulators can be estimated by calculating the total power loss from an efficiency measurement. The die temperature rise is calculated by multiplying the power dissipation of the LT3695 regulators by the thermal resistance from junction to ambient. Die temperature rise was measured on a 2-layer, 10cm \times 10cm circuit board in still air at a load current of 1A ($f_{\text{SW}} =$

800kHz). For a 12V input to 5V output the die temperature elevation above ambient was 22°C with the exposed pad soldered and 44°C without the exposed pad soldered.

Fault Tolerance

The LT3695 regulators are designed to tolerate single fault conditions. Shorting two adjacent pins together or leaving one single pin floating does not raise V_{OUT} or cause damage to the LT3695 regulators. However, the application circuit must meet the requirements discussed in this section in order to achieve this tolerance level.

Tables 5 and 6 show the effects that result from shorting adjacent pins or from a floating pin, respectively.

For the best fault tolerance to inadvertent adjacent pin shorts, the RUN/SS pin must not be directly connected to either ground or V_{IN} . If there was a short between RUN/SS and SW then connecting RUN/SS to V_{IN} would tie SW to V_{IN} and would thus raise V_{OUT} . Likewise, grounding RUN/SS would tie SW to ground and would damage the power switch if this is done when the power switch is on. A short between RT and a RUN/SS pin that is connected to V_{IN} would violate the absolute maximum ratings of the RT pin. Therefore, the current supplying the RUN/SS pin must be limited, for example, with resistor R3 in Figures 11 and 12. In case of a short between RUN/SS and SW this resistor charges C2 through the inductor L1 if the current it supplies from V_{IN} is not completely drawn by R_{LOAD} , R1

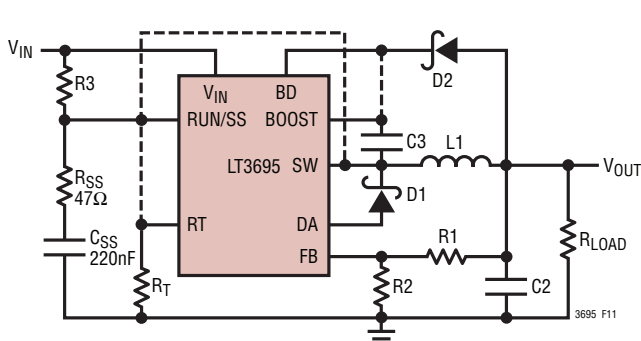

Figure 11. LT3695: The Dashed Lines Show Where a Connection Would Occur if There Were an Inadvertent Short from RUN/SS to an Adjacent Pin or from BOOST to BD. In These Cases, R3 Protects Circuitry Tied to the RT or SW Pins, and D2 Shields BOOST from V_{OUT} . If C_{SS} Is Used for Soft Start, R_{SS} Isolates It from SW

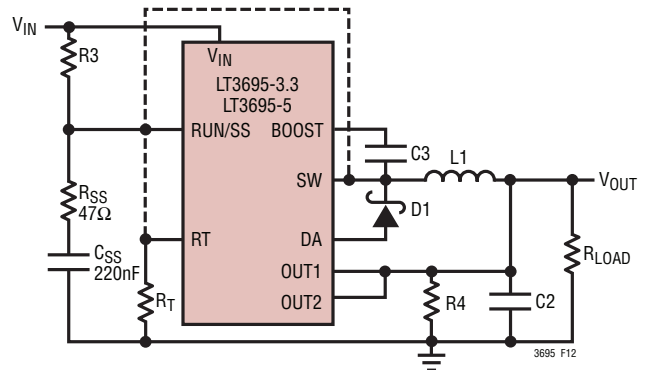

Figure 12. LT3695-3.3, LT3695-5: The Dashed Lines Show Where a Connection Would Occur if There Were an Inadvertent Short from RUN/SS to an Adjacent Pin. In These Cases, R3 Protects Circuitry Tied to the RT or SW Pins. R4 Provides an Additional Load and May Be Necessary in Certain Situations (See Text). If C_{SS} Is Used for Soft Start, R_{SS} Isolates It from SW

APPLICATIONS INFORMATION

Table 5: Effects of Pin Shorts

| PINS | EFFECT |
|---------------------------------|--|
| PGND-DA | No effect if $V_{IN} < V_{IN(MAX)}$. See Input Voltage Range section for description of $V_{IN(MAX)}$. |
| SW-RUN/SS | The result of this short depends on the load resistance and on R3 (Figure 10). See the following discussion. |
| RUN/SS-RT | No effect or V_{OUT} will fall below regulation voltage if I_{R3} (Figure 10) $< 1\text{mA}$. |
| RT-SYNC | No effect or V_{OUT} will fall below regulation voltage if the current into the RT pin is less than 1mA. |
| SYNC- V_{IN} | No effect if V_{IN} does not exceed the absolute maximum voltage of SYNC (20V). |
| PG-GND | No effect. |
| GND-BD (LT3695) | V_{OUT} may fall below regulation voltage, power dissipation of the power switch will be increased. Note that this short also grounds the voltage source supplying BD. Make sure it is safe to short the supply for BD to ground. For this reason BD should not be connected to V_{IN} , but it is safe to connect it to V_{OUT} . |
| BD-BOOST (LT3695) | If diode D2 (see Figure 10) is used, no effect or V_{OUT} may fall below regulation voltage. Otherwise the device may be damaged. |
| GND-OUT2 (LT3695-3.3, LT3695-5) | V_{OUT} will fall below regulation voltage, because this shorts the output to ground. As a result, the power dissipation of the part may increase. |

Table 6: Effects of Floating Pins

| PIN | EFFECT |
|-----------------------------------|---|
| PGND | No effect if the Exposed Pad is soldered. Otherwise: V_{OUT} may fall below regulation voltage. Make sure that $V_{IN} < V_{IN(MAX)}$ (see Input Voltage Range section for details) and provide a bypass resistor at the DA pin. See the following discussion. |
| DA | V_{OUT} may fall below regulation voltage. Make sure that $V_{IN} < V_{IN(MAX)}$ (see Input Voltage Range section for details) and provide a bypass resistor. See the following discussion. |
| SW | V_{OUT} will fall below regulation voltage. |
| RUN/SS | V_{OUT} will fall below regulation voltage. |
| RT | V_{OUT} will fall below regulation voltage. |
| SYNC | V_{OUT} may fall below regulation voltage. A floating SYNC pin configures the LT3695 for pulse-skipping mode. However, a floating SYNC pin is sensitive to noise which can degrade device performance. |
| V_{IN} | V_{OUT} will fall below regulation voltage. |
| V_C | V_{OUT} may fall below regulation voltage. Disconnecting the V_C pin alters the loop compensation and potentially degrades device performance. The output voltage ripple will increase if the part becomes unstable. |
| FB (LT3695) | V_{OUT} will fall below regulation voltage. |
| PG | No effect. |
| GND | Output maintains regulation, but potential degradation of device performance. |
| BD (LT3695) | V_{OUT} may fall below regulation voltage. If BD is not connected, the boost capacitor cannot be charged and thus the power switch cannot saturate properly, which increases its power dissipation. |
| OUT1, OUT2 (LT3695-3.3, LT3695-5) | No effect. |
| BOOST | V_{OUT} may fall below regulation voltage. If BOOST is not connected, the boost capacitor cannot be charged and thus the power switch cannot saturate properly, which increases its power dissipation. |

APPLICATIONS INFORMATION

+ R2, and the BD pin (if connected to V_{OUT}) in the case of the LT3695, or by R_{LOAD} , R4 and the OUT1,2 pins in the case of the LT3695-3.3 and LT3695-5. Since this causes V_{OUT} to rise, the LT3695 regulators stop switching. The resistive divider formed by R3, R_{LOAD} and R1 + R2 and R4, respectively, must be adjusted for V_{OUT} not to exceed its nominal value at the required maximum input voltage $V_{IN(MAX)}$. R3 must supply sufficient current into RUN/SS at the required minimum input voltage $V_{IN(MIN)}$ for normal non-fault situations. Based on the maximum RUN/SS current of $7.5\mu A$ at $V_{RUN/SS} = 2.5V$ this gives

$$R3 \leq \frac{V_{IN(MIN)} - 2.5V}{7.5\mu A}$$

The current through R3 is maximal at $V_{IN(MAX)}$ with RUN/SS shorted to SW:

$$I_{R3} = \frac{V_{IN(MAX)} - V_{OUT}}{R3}$$

For the LT3695, this current must be drawn by R_{LOAD} , R1 + R2, and the BD pin, if connected to V_{OUT} :

$$I_{R3} \leq \frac{V_{OUT}}{R_{LOAD} \parallel (R1 + R2)} + I_{BD}$$

Without load ($R_{LOAD} = \infty$) and assuming the minimum current of $35\mu A$ into the BD pin, this leads to

$$R1 + R2 \leq \frac{V_{OUT}}{\frac{V_{IN(MAX)} - V_{OUT}}{R3} - 35\mu A}$$

as upper limit for the feedback resistors. For $V_{OUT} < 2.5V$ assume no current drawn by the BD pin, which gives

$$R1 + R2 \leq \frac{V_{OUT} \cdot R3}{V_{IN(MAX)} - V_{OUT}}$$

For the LT3695-3.3 and LT3695-5, the current through R3 must be drawn by R_{LOAD} , R4 and the OUT1,2 pins:

$$I_{R3} \leq \frac{V_{OUT}}{R_{LOAD} \parallel R4} + I_{OUT1,2}$$

Without load ($R_{LOAD} = \infty$) and assuming the minimum current of $43\mu A$ into the OUT1,2 pins, this leads to:

$$R4 \leq \frac{V_{OUT}}{\frac{V_{IN(MAX)} - V_{OUT}}{R3} - 43\mu A}$$

as upper limit for R4. Depending on the required input voltage range, R4 may be omitted.

Tables 7 and 8 show example values for common applications. R_{SS} must be included as the switch node would otherwise have to charge C_{SS} if the SW pin and the RUN/SS pin are shorted, which may damage the power switch.

If RUN/SS is controlled by an external circuitry, the current this circuitry can supply must be limited. This can be done as discussed above. In addition, it may be necessary to protect this external circuitry from the voltage at SW, for example by using a diode.

Table 7. LT3695: Example Values for R1, R2 and R3 for Common Combinations of V_{IN} and V_{OUT} . I_{R1+R2} is the Current Drawn by R1 + R2 in Normal Operation

| $V_{IN(MAX)}$ (V) | $V_{IN(MIN)}$ (V) | V_{OUT} (V) | R3 (k Ω) | R1 (k Ω) | R2 (k Ω) | I_{R1+R2} (μA) |
|----------------------|----------------------|------------------|---------------------|---------------------|---------------------|----------------------------|
| 16 | 3.8 | 1.8 | 169 | 11.5 | 9.09 | 87 |
| 36 | 3.8 | 1.8 | 169 | 4.75 | 3.74 | 212 |
| 16 | 4.5 | 2.5 | 261 | 93.1 | 43.2 | 18 |
| 36 | 4.5 | 2.5 | 261 | 16.9 | 7.87 | 101 |
| 16 | 5.3 | 3.3 | 365 | 432 | 137 | 6 |
| 36 | 5.3 | 3.3 | 365 | 43.2 | 13.7 | 58 |
| 16 | 7 | 5 | 274 | 536 | 102 | 8 |
| 36 | 7 | 5 | 590 | 221 | 42.2 | 19 |
| 16 | 10 | 8 | 200 | 562 | 61.9 | 13 |
| 36 | 10 | 8 | 475 | 280 | 30.9 | 26 |
| 27 | 14 | 12 | 301 | 511 | 36.5 | 22 |
| 36 | 14 | 12 | 442 | 511 | 36.5 | 22 |

APPLICATIONS INFORMATION

Table 8. LT3695-3.3, LT3695-5: Example Values for R3 and R4 for Common Combinations of V_{IN} and V_{OUT} . I_{R4} is the Current Drawn by R4 in Normal Operation

| $V_{IN(MAX)}$ (V) | $V_{IN(MIN)}$ (V) | V_{OUT} (V) | R3 (k Ω) | R4 (k Ω) | I_{R4} (μ A) |
|----------------------|----------------------|------------------|---------------------|---------------------|------------------------|
| 16 | 5.3 | 3.3 | 309 | None | |
| 24 | 5.3 | 3.3 | 365 | 215 | 15 |
| 36 | 5.3 | 3.3 | 365 | 66.5 | 50 |
| 16 | 7 | 5 | 267 | None | |
| 24 | 7 | 5 | 464 | None | |
| 36 | 7 | 5 | 590 | 442 | 11 |

The BOOST pin must not be shorted to a low impedance node like V_{OUT} that clamps its voltage. For best fault tolerance of the LT3695, supply current into the BD pin through the Schottky diode D2 as shown in Figure 10. Note that this diode must be able to handle the maximum output current in case there is a short between the BD pin and the GND pin.

A short between RUN/SS and SW may also increase the output ripple. To suppress this, connect the soft-start network consisting of R_{SS} and C_{SS} to RUN/SS as shown in Figure 10. C_{SS} should not be smaller than 0.22 μ F.

The SYNC pin must not be directly connected to either ground or V_{IN} . A short between RT and a SYNC pin that is connected to V_{IN} could violate the absolute maximum ratings of the RT pin. A short between the SYNC pin and the V_{IN} pin could damage an external driver circuit which may be connected to SYNC or would short V_{IN} to ground if SYNC is grounded.

The recommended connection for SYNC is shown in Figure 13. If SYNC is to be driven by an external circuitry, R_S may be used to isolate this circuitry from V_{IN} . C_S must be used in this case to provide a low impedance path for the synchronization signal. If SYNC is pulled low, R_S prevents V_{IN} from being shorted to ground in case of an inadvertent short between SYNC and V_{IN} . If SYNC is pulled high to V_{IN} , then R_S protects the RT pin during an inadvertent short between SYNC and RT.

If the DA pin or the PGND pin are inadvertently left floating, the current path of the catch diode is interrupted unless a bypass resistor is connected from DA to ground. Use a 360m Ω (5% tolerance) resistor rated for a power dissipation of:

$$P = I_{LOAD(MAX)}^2 \cdot 0.36 \cdot (1 - DC_{MIN})$$

where $I_{LOAD(MAX)}$ is the maximum load current and DC_{MIN} is the minimum duty cycle. For example, this would require a power rating of at least 219mW for an output current of 800mA and a minimum duty cycle of 5%. Make sure not to exceed $V_{IN(MAX)}$ (see Input Voltage Range section for details) during start-up or overload conditions.

Other Linear Technology Publications

Application Notes 19, 35 and 44 contain more detailed descriptions and design information for buck regulators and other switching regulators. The LT1376 data sheet has a more extensive discussion of output ripple, loop compensation and stability testing. Design Note 318 shows how to generate a bipolar output supply using a buck regulator.

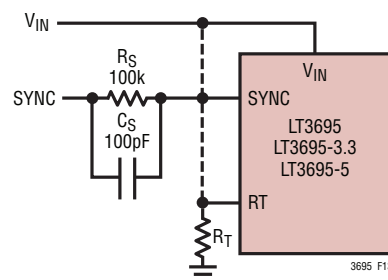
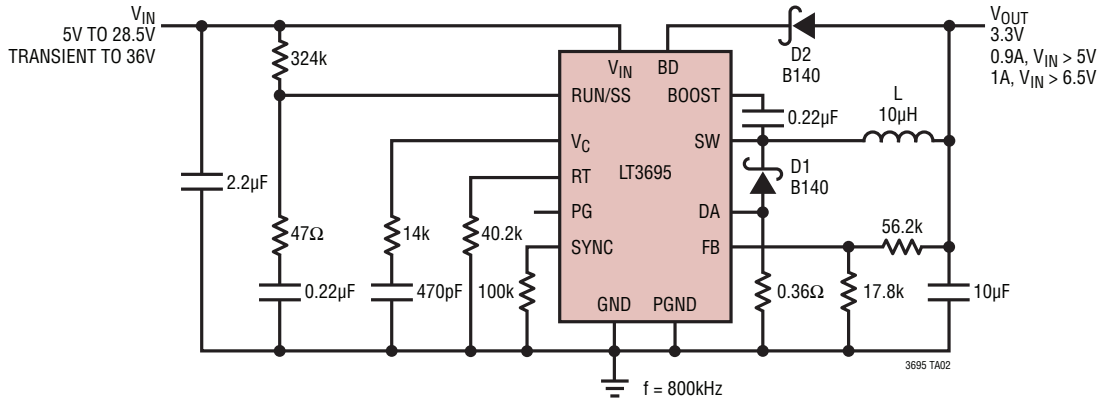

Figure 13. The Dashed Lines Show Where a Connection Would Occur if There Were an Inadvertent Short from SYNC to an Adjacent Pin. In This Case, R_S Protects Circuitry Connecting to SYNC

TYPICAL APPLICATIONS

Fully Tolerant 3.3V Step-Down Converter with Soft-Start



1.8V Step-Down Converter

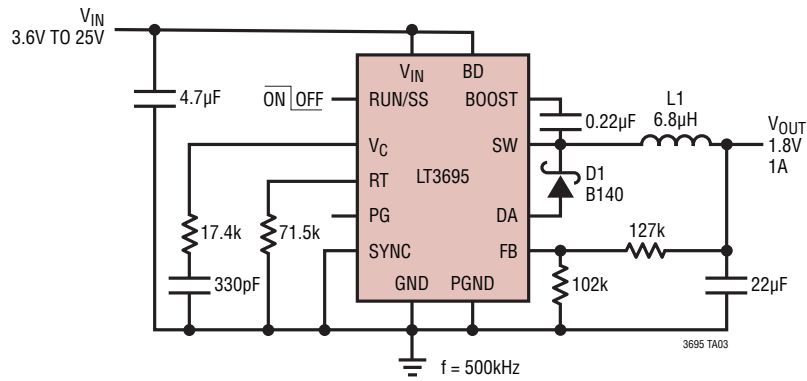

TYPICAL APPLICATIONS

Fully Tolerant 5V Step-Down Converter with Soft-Start

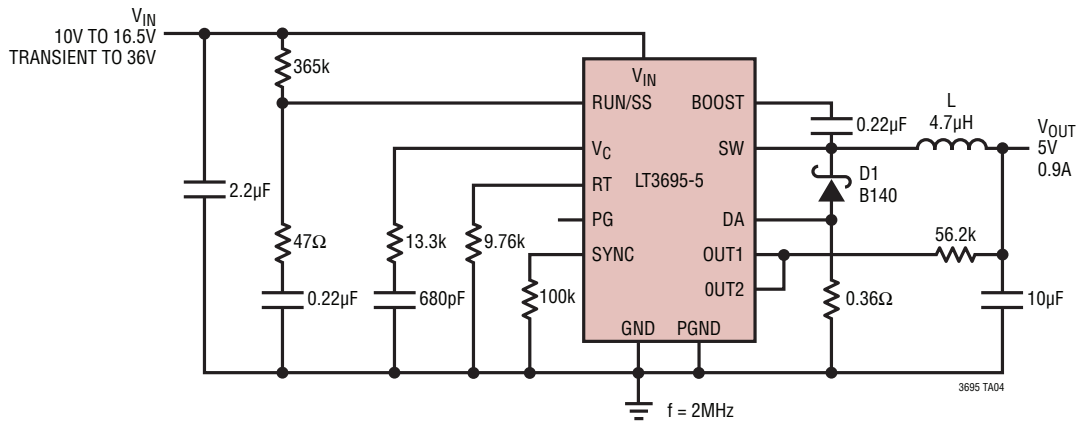

PACKAGE DESCRIPTION

MSE Package 16-Lead Plastic MSOP, Exposed Die Pad (Reference LTC DWG # 05-08-1667 Rev A)

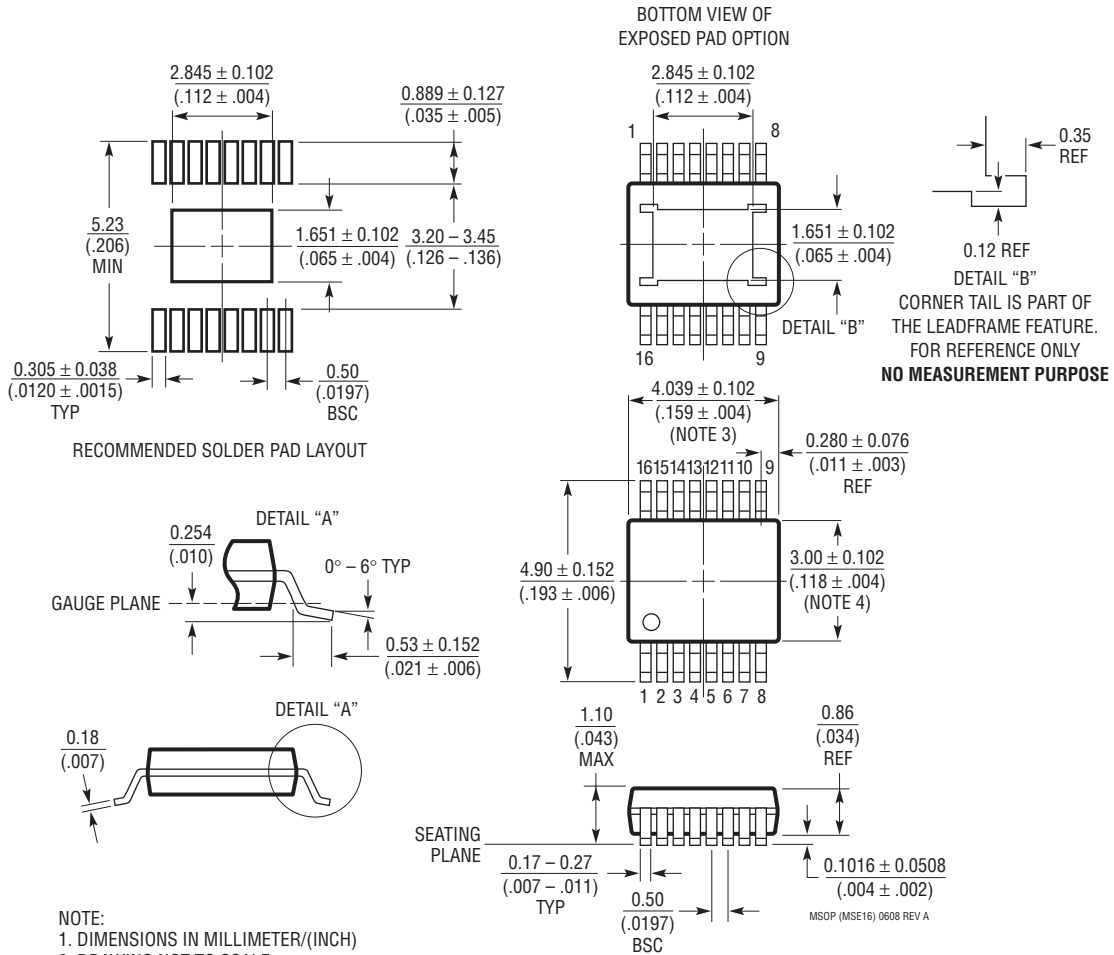

- NOTE:
1. DIMENSIONS IN MILLIMETER/(INCH)
 2. DRAWING NOT TO SCALE
 3. DIMENSION DOES NOT INCLUDE MOLD FLASH, PROTRUSIONS OR GATE BURRS.
MOLD FLASH, PROTRUSIONS OR GATE BURRS SHALL NOT EXCEED 0.152mm (.006") PER SIDE
 4. DIMENSION DOES NOT INCLUDE INTERLEAD FLASH OR PROTRUSIONS.
INTERLEAD FLASH OR PROTRUSIONS SHALL NOT EXCEED 0.152mm (.006") PER SIDE
 5. LEAD COPLANARITY (BOTTOM OF LEADS AFTER FORMING) SHALL BE 0.102mm (.004") MAX

REVISION HISTORY

| REV | DATE | DESCRIPTION | PAGE NUMBER |
|-----|-------|---|-------------|
| A | 11/09 | All Sections Revised to Include LT3695-3.3 and LT3695-5 | 1-30 |

TYPICAL APPLICATION

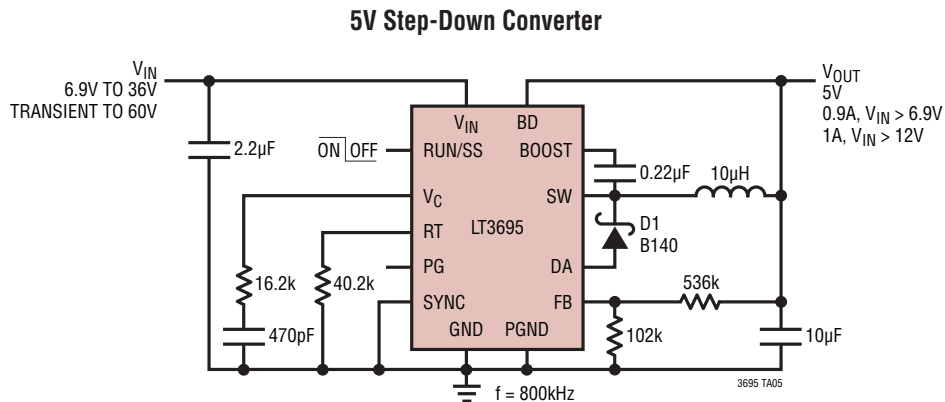



RELATED PARTS

| PART NUMBER | DESCRIPTION | COMMENTS |
|---------------|---|--|
| LT3970 | 40V, 350mA, 2MHz High Efficiency MicroPower Step-Down DC/DC Converter | V_{IN} : 4V to 40V Transient to 60V, $V_{OUT(MAX)}$ = 1.21V, I_Q = 2µA, I_{SD} < 1µA, 3mm × 2mm DFN-10, MSOP-10 Packages |
| LT3689 | 36V, 60V Transient Protection, 800mA, 2.2MHz High Efficiency MicroPower Step-Down DC/DC Converter with POR Reset and Watchdog Timer | V_{IN} : 3.6V to 36V Transient to 60V, $V_{OUT(MAX)}$ = 0.8V, I_Q = 75µA, I_{SD} < 1µA, 3mm × 3mm QFN-16 Package |
| LT3685 | 36V with Transient Protection to 60V, 2A (I_{OUT}), 2.4MHz, High Efficiency Step-Down DC/DC Converter | V_{IN} : 3.6V to 38V, $V_{OUT(MAX)}$ = 0.78V, I_Q = 70µA, I_{SD} < 1µA, 3mm × 3mm DFN-10, MSOP-10E Packages |
| LT3684 | 34V with Transient Protection to 36V, 2A (I_{OUT}), 2.8MHz, High Efficiency Step-Down DC/DC Converter | V_{IN} : 3.6V to 34V, $V_{OUT(MAX)}$ = 1.26V, I_Q = 850µA, I_{SD} < 1µA, 3mm × 3mm DFN-10, MSOP-10E Packages |
| LT3682 | 36V, 60V _{MAX} , 1A, 2.2MHz High Efficiency Micropower Step-Down DC/DC Converter | V_{IN} : 3.6V to 36V, $V_{OUT(MAX)}$ = 0.8V, I_Q = 75µA, I_{SD} < 1µA, 3mm × 3mm DFN-12 Package |
| LT3508 | 36V with Transient Protection to 40V, Dual 1.4A (I_{OUT}), 3MHz, High Efficiency Step-Down DC/DC Converter | V_{IN} : 3.7V to 36V, $V_{OUT(MAX)}$ = 0.8V, I_Q = 4.6mA, I_{SD} = 1µA, 4mm × 4mm QFN-24, TSSOP-16E Packages |
| LT3507 | 36V 2.5MHz, Triple (2.4A + 1.5A + 1.5A (I_{OUT})) with LDO Controller High Efficiency Step-Down DC/DC Converter | V_{IN} : 4V to 36V, $V_{OUT(MAX)}$ = 0.8V, I_Q = 7mA, I_{SD} = 1µA, 5mm × 7mm QFN-38 Package |
| LT3505 | 36V with Transient Protection to 40V, 1.4A (I_{OUT}), 3MHz, High Efficiency Step-Down DC/DC Converter | V_{IN} : 3.6V to 34V, $V_{OUT(MAX)}$ = 0.78V, I_Q = 2mA, I_{SD} = 2µA, 3mm × 3mm DFN-8, MSOP-8E Packages |
| LT3500 | 36V, 40V _{MAX} , 2A, 2.5MHz High Efficiency Step-Down DC/DC Converter and LDO Controller | V_{IN} : 3.6V to 36V, $V_{OUT(MAX)}$ = 0.8V, I_Q = 2.5mA, I_{SD} < 10µA, 3mm × 3mm DFN-10 Package |
| LT3493 | 36V, 1.4A (I_{OUT}), 750kHz High Efficiency Step-Down DC/DC Converter | V_{IN} : 3.6V to 36V, $V_{OUT(MAX)}$ = 0.8V, I_Q = 1.9mA, I_{SD} < 1µA, 2mm × 3mm DFN-6 Package |
| LT3481 | 34V with Transient Protection to 36V, 2A (I_{OUT}), 2.8MHz, High Efficiency Step-Down DC/DC Converter with Burst Mode Operation | V_{IN} : 3.6V to 34V, $V_{OUT(MAX)}$ = 1.26V, I_Q = 50µA, I_{SD} < 1µA, 3mm × 3mm DFN-10, MSOP-10E Packages |
| LT3480 | 36V with Transient Protection to 60V, 2A (I_{OUT}), 2.4MHz, High Efficiency Step-Down DC/DC Converter with Burst Mode Operation | V_{IN} : 3.6V to 38V, $V_{OUT(MAX)}$ = 0.78V, I_Q = 70µA, I_{SD} < 1µA, 3mm × 3mm DFN-10, MSOP-10E Packages |
| LT3437 | 60V, 400mA (I_{OUT}), MicroPower Step-Down DC/DC Converter with Burst Mode Operation | V_{IN} : 3.3V to 60V, $V_{OUT(MAX)}$ = 1.25V, I_Q = 100µA, I_{SD} < 1µA, 3mm × 3mm DFN-10, TSSOP-16E Package |
| LT3434/LT3435 | 60V, 2.4A (I_{OUT}), 200kHz/500kHz, High Efficiency Step-Down DC/DC Converter with Burst Mode Operation | V_{IN} : 3.3V to 60V, $V_{OUT(MAX)}$ = 1.2V, I_Q = 100µA, I_{SD} < 1µA, TSSOP-16E Package |
| LT1976/LT1977 | 60V, 1.2A (I_{OUT}), 200kHz/500kHz, High Efficiency Step-Down DC/DC Converter with Burst Mode Operation | V_{IN} : 3.3V to 60V, $V_{OUT(MAX)}$ = 1.2V, I_Q = 100µA, I_{SD} < 1µA, TSSOP-16E Package |
| LT1936 | 36V, 1.4A (I_{OUT}), 500kHz High Efficiency Step-Down DC/DC Converter | V_{IN} : 3.6V to 36V, $V_{OUT(MAX)}$ = 1.2V, I_Q = 1.9mA, I_{SD} < 1µA, MS8E Package |
| LT1766 | 60V, 1.2A (I_{OUT}), 200kHz, High Efficiency Step-Down DC/DC Converter | V_{IN} : 5.5V to 60V, $V_{OUT(MAX)}$ = 1.2V, I_Q = 2.5mA, I_{SD} = 25µA, TSSOP-16/E Package |

3695fa

Looking for pricing, stock, or lifecycle information?

Click below to explore more details on WIN SOURCE:

-  [View LT3695EMSE-5#PBF on WIN SOURCE](#)
-  [Analog Devices Inc. Information](#)

Optimize Your Supply Chain with WIN SOURCE Solutions

-  Global Sourcing Solution
-  Obsolete Management
-  Cost Control Management
-  Shortage Management
-  Alternative Solution
-  Excess Inventory Management