



# THE DATASHEET OF CD4069UBPWR



## CD4069UB CMOS hex inverter

### 1 Features

- Standardized symmetrical output characteristics
- Medium speed operation:  $t_{PHL}$ ,  $t_{PLH} = 30$  ns at 10 V (Typical)
- 100% Tested for quiescent current at 20 V
- Maximum input current of 1  $\mu$ A at 18 V over full package-temperature range, 100 nA at 18 V and 25°C
- Meets all requirements of JEDEC tentative standard No. 13B, *Standard Specifications for Description of B Series CMOS Devices*

### 2 Applications

- Logic inversion
- Pulse shaping
- Oscillators
- High-input-impedance amplifiers

### 3 Description

The CD4069UB device consist of six CMOS inverter circuits. These devices are intended for all general-purpose inverter applications where the medium-power TTL-drive and logic-level-conversion capabilities of circuits such as the CD4009 and CD4049 hex inverter and buffers are not required.

#### Device Information<sup>(1)</sup>

PART NUMBER	PACKAGE (PINS)	BODY SIZE (NOM)
CD4069UBE	PDIP (14)	19.30 mm x 6.35 mm
CD4069UBF	CDIP (14)	19.56 mm x 6.67 mm
CD4069UBM	SOIC (14)	8.65 mm x 3.91 mm
CD4069UBNSR	SO (14)	10.30 mm x 5.30 mm
CD4069UBPW	TSSOP (14)	5.00 mm x 4.40 mm

(1) For all available packages, see the orderable addendum at the end of the data sheet.

#### CD4069UB Functional Diagram

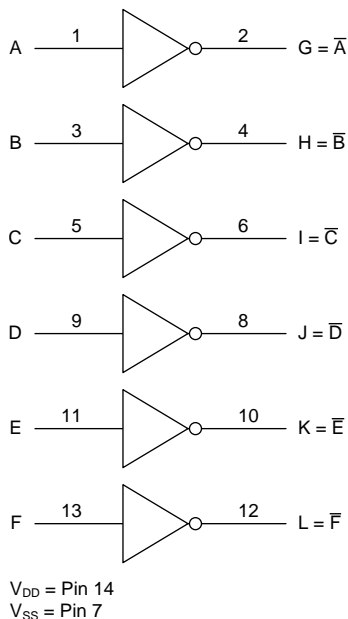

## Table of Contents

<b>1 Features</b> .....	<b>1</b>	8.3 Feature Description .....	<b>13</b>
<b>2 Applications</b> .....	<b>1</b>	8.4 Device Functional Modes .....	<b>13</b>
<b>3 Description</b> .....	<b>1</b>	<b>9 Application and Implementation</b> .....	<b>14</b>
<b>4 Revision History</b> .....	<b>2</b>	9.1 Application Information .....	<b>14</b>
<b>5 Pin Configuration and Functions</b> .....	<b>3</b>	9.2 Typical Application .....	<b>14</b>
<b>6 Specifications</b> .....	<b>4</b>	<b>10 Power Supply Recommendations</b> .....	<b>16</b>
6.1 Absolute Maximum Ratings .....	4	<b>11 Layout</b> .....	<b>16</b>
6.2 ESD Ratings .....	4	11.1 Layout Guidelines .....	16
6.3 Recommended Operating Conditions .....	4	11.2 Layout Example .....	16
6.4 Thermal Information .....	4	<b>12 Device and Documentation Support</b> .....	<b>17</b>
6.5 Electrical Characteristics – Dynamic .....	5	12.1 Device Support .....	17
6.6 Electrical Characteristics – Static .....	5	12.2 Documentation Support .....	17
6.7 Typical Characteristics .....	8	12.3 Community Resource .....	17
<b>7 Parameter Measurement Information</b> .....	<b>9</b>	12.4 Trademarks .....	17
<b>8 Detailed Description</b> .....	<b>13</b>	12.5 Electrostatic Discharge Caution .....	17
8.1 Overview .....	13	12.6 Glossary .....	17
8.2 Functional Block Diagram .....	13	<b>13 Mechanical, Packaging, and Orderable Information</b> .....	<b>17</b>

## 4 Revision History

NOTE: Page numbers for previous revisions may differ from page numbers in the current version.

Changes from Revision D (February 2016) to Revision E	Page
• Removed artifact "-" at $t_{PHL}$ term on the second Features bullet .....	1
• Corrected $V_I$ spec MIN/MAX values in the Abs Max Ratings table .....	4
• Corrected parameter $I_{DD}$ max term to $I_{DD}$ in the Elec Characteristics table .....	5
• Corrected parameter $I_{OL}$ min term to $I_{OL}$ in the Elec Characteristics table .....	5
• Corrected parameter $V_{OL}$ max term to $V_{OL}$ in the Elec Characteristics table .....	6
• Corrected parameter $V_{IL}$ max term to $V_{IL}$ in the Elec Characteristics table .....	6
• Corrected parameter $V_{IH}$ min term to $V_{IH}$ in the Elec Characteristics table .....	6
• Corrected parameter $I_{IN}$ max term to $I_{IN}$ in the Elec Characteristics table .....	7
• Added Y-axis label to <a href="#">Figure 1</a> image object .....	8
• Changed text string from " $-t_{PHL}$ " to "of $t_{PHL}$ " in the Feature Description paragraph. ....	13

Changes from Revision C (August 2003) to Revision D	Page
• Added <i>ESD Ratings</i> table, <i>Feature Description</i> section, <i>Device Functional Modes</i> , <i>Application and Implementation</i> section, <i>Power Supply Recommendations</i> section, <i>Layout</i> section, <i>Device and Documentation Support</i> section, and <i>Mechanical, Packaging, and Orderable Information</i> section .....	1

## 5 Pin Configuration and Functions

**D, J, N, NS, and PW Packages**  
**14-Pin PDIP, CDIP, SOIC, SO, and TSSOP**  
**Top View**

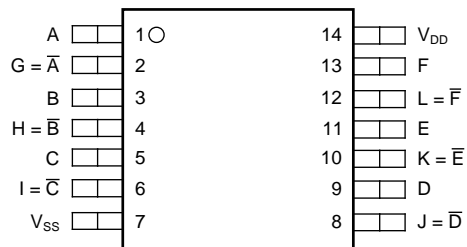

**Pin Functions**

PIN		I/O	DESCRIPTION
NAME	NO.		
A	1	I	A input
B	3	I	B input
C	5	I	C input
D	9	I	D input
E	11	I	E input
F	13	I	F input
$G = \bar{A}$	2	O	G output
$H = \bar{B}$	4	O	H output
$I = \bar{C}$	6	O	I output
$J = \bar{D}$	8	O	J output
$K = \bar{E}$	10	O	K output
$L = \bar{F}$	12	O	L output
$V_{DD}$	14	—	Positive supply
$V_{SS}$	7	—	Negative supply

## 6 Specifications

### 6.1 Absolute Maximum Ratings

over operating free-air temperature range (unless otherwise noted)<sup>(1)</sup>

		MIN	MAX	UNIT
V <sub>DD</sub>	DC supply-voltage (voltages referenced to V <sub>SS</sub> terminal)	-0.5	20	V
V <sub>I</sub>	Input voltage, all inputs	-0.5	V <sub>DD</sub> + 0.5	V
I <sub>IK</sub>	DC input current, any one input	-10	10	mA
P <sub>D</sub>	Power dissipation per package	-55°C to 100°C	500	mW
		100°C to 125°C	12	
	Device dissipation per output transistor	Full range (all package types)		100
Lead temperature <sup>(2)</sup>			265	°C
T <sub>J</sub>	Junction temperature		150	°C
T <sub>stg</sub>	Storage temperature	-65	150	°C

- (1) Stresses beyond those listed under *Absolute Maximum Ratings* may cause permanent damage to the device. These are stress ratings only, which do not imply functional operation of the device at these or any other conditions beyond those indicated under *Recommended Operating Conditions*. Exposure to absolute-maximum-rated conditions for extended periods may affect device reliability.
- (2) During soldering at distance 1/16 inch ± 1/32 inch (1.59 mm ± 0.79 mm) from case for 10 s maximum

### 6.2 ESD Ratings

		VALUE	UNIT
V <sub>(ESD)</sub>	Electrostatic discharge	Human-body model (HBM), per ANSI/ESDA/JEDEC JS-001 <sup>(1)</sup>	±500
		Charged-device model (CDM), per JEDEC specification JESD22-C101 <sup>(2)</sup>	±200

- (1) JEDEC document JEP155 states that 500-V HBM allows safe manufacturing with a standard ESD control process.
- (2) JEDEC document JEP157 states that 250-V CDM allows safe manufacturing with a standard ESD control process.

### 6.3 Recommended Operating Conditions

over operating free-air temperature range (unless otherwise noted)

		MIN	MAX	UNIT
V <sub>DD</sub>	Supply voltage	3	18	V
T <sub>A</sub>	Operating temperature	-55	125	°C

### 6.4 Thermal Information

THERMAL METRIC <sup>(1)</sup>	CD4069UB					UNIT	
	D (SOIC)	J (CDIP)	N (PDIP)	NS (SO)	PW (TSSOP)		
	14 PINS	14 PINS	14 PINS	14 PINS	14 PINS		
R <sub>θJA</sub>	Junction-to-ambient thermal resistance	94.9	—	57.9	91.2	122.1	°C/W
R <sub>θJC(top)</sub>	Junction-to-case (top) thermal resistance	56.4	28.5	45.5	48.8	50.8	°C/W
R <sub>θJB</sub>	Junction-to-board thermal resistance	49.2	—	37.7	50	63.8	°C/W
ψ <sub>JT</sub>	Junction-to-top characterization parameter	21.1	—	30.6	15	6.3	°C/W
ψ <sub>JB</sub>	Junction-to-board characterization parameter	48.9	—	37.6	49.6	63.3	°C/W
R <sub>θJC(bot)</sub>	Junction-to-case (bottom) thermal resistance	N/A	N/A	N/A	N/A	N/A	°C/W

- (1) For more information about traditional and new thermal metrics, see the *Semiconductor and IC Package Thermal Metrics* application report, [SPRA953](#).

## 6.5 Electrical Characteristics – Dynamic

 $T_A = 25^\circ\text{C}$ ; input  $t_r, t_f = 20\text{ ns}$ ;  $C_L = 50\text{ pF}$ ;  $R_L = 200\text{ k}\Omega$  (unless otherwise noted)

PARAMETER	TEST CONDITIONS	MIN	TYP	MAX	UNIT
$t_{PLH}, t_{PHL}$ Propagation delay time	$V_{DD} (V) = 5$		55	110	ns
	$V_{DD} (V) = 10$		30	60	
	$V_{DD} (V) = 15$		25	50	
$t_{THL}, t_{TLH}$ Transition time	$V_{DD} (V) = 5$		100	200	ns
	$V_{DD} (V) = 10$		50	100	
	$V_{DD} (V) = 15$		40	80	
$C_{IN}$ Input capacitance	Any input		10	15	pF

## 6.6 Electrical Characteristics – Static

 $T_A = 25^\circ\text{C}$ ; input  $t_r, t_f = 20\text{ ns}$ ;  $C_L = 50\text{ pF}$ ;  $R_L = 200\text{ k}\Omega$  (unless otherwise noted)

PARAMETER	TEST CONDITIONS	MIN	TYP	MAX	UNIT	
$I_{DD}$ Quiescent device current	$V_{IN} = 0\text{V or } 5\text{ V}, V_{DD} = 5\text{ V}$	$T_A = -55^\circ\text{C}$			0.25	$\mu\text{A}$
		$T_A = -40^\circ\text{C}$			0.25	
		$T_A = 25^\circ\text{C}$		0.01	0.25	
		$T_A = 85^\circ\text{C}$			7.5	
		$T_A = 125^\circ\text{C}$			7.5	
	$V_{IN} = 0\text{ or } 10\text{ V}, V_{DD} = 10\text{ V}$	$T_A = -55^\circ\text{C}$			0.5	
		$T_A = -40^\circ\text{C}$			0.5	
		$T_A = 25^\circ\text{C}$		0.01	0.5	
		$T_A = 85^\circ\text{C}$			15	
		$T_A = 125^\circ\text{C}$			15	
	$V_{IN} = 0\text{ or } 15\text{ V}, V_{DD} = 15\text{ V}$	$T_A = -55^\circ\text{C}$			1	
		$T_A = -40^\circ\text{C}$			1	
		$T_A = 25^\circ\text{C}$		0.01	1	
		$T_A = 85^\circ\text{C}$			30	
		$T_A = 125^\circ\text{C}$			30	
	$V_{IN} = 0\text{ or } 20\text{ V}, V_{DD} = 20\text{ V}$	$T_A = -55^\circ\text{C}$			5	
$T_A = -40^\circ\text{C}$				5		
$T_A = 25^\circ\text{C}$			0.02	5		
$T_A = 85^\circ\text{C}$				150		
$T_A = 125^\circ\text{C}$				150		
$I_{OL}$ Output low (sink) current	$V_O = 0.4\text{ V}, V_{IN} = 5\text{ V}, V_{DD} = 5\text{ V}$	$T_A = -55^\circ\text{C}$	0.64		mA	
		$T_A = -40^\circ\text{C}$	0.61			
		$T_A = 25^\circ\text{C}$	0.51	1		
		$T_A = 85^\circ\text{C}$	0.42			
		$T_A = 125^\circ\text{C}$	0.36			
	$V_O = 0.5\text{ V}, V_{IN} = 10\text{ V}, V_{DD} = 10\text{ V}$	$T_A = -55^\circ\text{C}$	1.6			
		$T_A = -40^\circ\text{C}$	1.5			
		$T_A = 25^\circ\text{C}$	1.3	2.6		
		$T_A = 85^\circ\text{C}$	1.1			
		$T_A = 125^\circ\text{C}$	0.9			
	$V_O = 1.5\text{ V}, V_{IN} = 15\text{ V}, V_{DD} = 15\text{ V}$	$T_A = -55^\circ\text{C}$	4.2			
		$T_A = -40^\circ\text{C}$	4			
		$T_A = 25^\circ\text{C}$	3.4	6.8		
		$T_A = 85^\circ\text{C}$	2.8			
		$T_A = 125^\circ\text{C}$	2.4			

**Electrical Characteristics – Static (continued)**
 $T_A = 25^\circ\text{C}$ ; input  $t_r, t_f = 20\text{ ns}$ ;  $C_L = 50\text{ pF}$ ;  $R_L = 200\text{ k}\Omega$  (unless otherwise noted)

PARAMETER	TEST CONDITIONS	MIN	TYP	MAX	UNIT	
$I_{OH}$	$V_O = 4.6\text{ V}, V_{IN} = 0\text{ V}, V_{DD} = 5\text{ V}$	$T_A = -55^\circ\text{C}$	-0.64			mA
		$T_A = -40^\circ\text{C}$	-0.61			
		$T_A = 25^\circ\text{C}$	-0.51	-1		
		$T_A = 85^\circ\text{C}$	-0.42			
		$T_A = 125^\circ\text{C}$	-0.36			
	$V_O = 2.5\text{ V}, V_{IN} = 0\text{ V}, V_{DD} = 5\text{ V}$	$T_A = -55^\circ\text{C}$	-2			
		$T_A = -40^\circ\text{C}$	-1.8			
		$T_A = 25^\circ\text{C}$	-1.6	-3.2		
		$T_A = 85^\circ\text{C}$	-1.3			
		$T_A = 125^\circ\text{C}$	-1.15			
	$V_O = 9.5\text{ V}, V_{IN} = 0\text{ V}, V_{DD} = 10\text{ V}$	$T_A = -55^\circ\text{C}$	-1.6			
		$T_A = -40^\circ\text{C}$	-1.5			
		$T_A = 25^\circ\text{C}$	-1.3	-2.6		
		$T_A = 85^\circ\text{C}$	-1.1			
		$T_A = 125^\circ\text{C}$	-0.9			
	$V_O = 13.5\text{ V}, V_{IN} = 0\text{ V}, V_{DD} = 15\text{ V}$	$T_A = -55^\circ\text{C}$	-4.2			
$T_A = -40^\circ\text{C}$		-4				
$T_A = 25^\circ\text{C}$		-3.4	-6.8			
$T_A = 85^\circ\text{C}$		-2.8				
$T_A = 125^\circ\text{C}$		-2.4				
$V_{OL}$	$V_{IN} = 5\text{ V}, V_{DD} = 5\text{ V}$	$T_A = 25^\circ\text{C}$		0	0.05	V
		All other temperatures			0.05	
	$V_{IN} = 10\text{ V}, V_{DD} = 10\text{ V}$	$T_A = 25^\circ\text{C}$		0	0.05	
		All other temperatures			0.05	
	$V_{IN} = 15\text{ V}, V_{DD} = 15\text{ V}$	$T_A = 25^\circ\text{C}$		0	0.05	
		All other temperatures			0.05	
$V_{OH}$	$V_{IN} = 0\text{ V}, V_{DD} = 5\text{ V}$	$T_A = 25^\circ\text{C}$	4.95	5		V
		All other temperatures	4.95			
	$V_{IN} = 0\text{ V}, V_{DD} = 10\text{ V}$	$T_A = 25^\circ\text{C}$	9.95	10		
		All other temperatures	9.95			
	$V_{IN} = 0\text{ V}, V_{DD} = 15\text{ V}$	$T_A = 25^\circ\text{C}$	14.95	15		
		All other temperatures	14.95			
$V_{IL}$	$V_O = 4.5\text{ V}, V_{DD} = 5\text{ V}, \text{ all temperatures}$				1	V
	$V_O = 9\text{ V}, V_{DD} = 10\text{ V}, \text{ all temperatures}$				2	
	$V_O = 13.5\text{ V}, V_{DD} = 15\text{ V}, \text{ all temperatures}$				2.5	
$V_{IH}$	$V_O = 0.5\text{ V}, V_{DD} = 5\text{ V}, \text{ all temperatures}$		4			V
	$V_O = 1\text{ V}, V_{DD} = 10\text{ V}, \text{ all temperatures}$		8			
	$V_O = 1.5\text{ V}, V_{DD} = 15\text{ V}, \text{ all temperatures}$		12.5			

**Electrical Characteristics – Static (continued)**
 $T_A = 25^\circ\text{C}$ ; input  $t_r, t_f = 20\text{ ns}$ ;  $C_L = 50\text{ pF}$ ;  $R_L = 200\text{ k}\Omega$  (unless otherwise noted)

PARAMETER	TEST CONDITIONS	MIN	TYP	MAX	UNIT
$I_{IN}$ Input current	$V_{IN} = 0\text{ V to }18\text{ V}, V_{DD} = 18\text{ V}$	$T_A = -55^\circ\text{C}$		$\pm 01$	$\mu\text{A}$
		$T_A = -40^\circ\text{C}$		$\pm 01$	
		$T_A = 25^\circ\text{C}$		$\pm 10^{-5}$	
		$T_A = 85^\circ\text{C}$		$\pm 1$	
		$T_A = 125^\circ\text{C}$		$\pm 1$	

## 6.7 Typical Characteristics

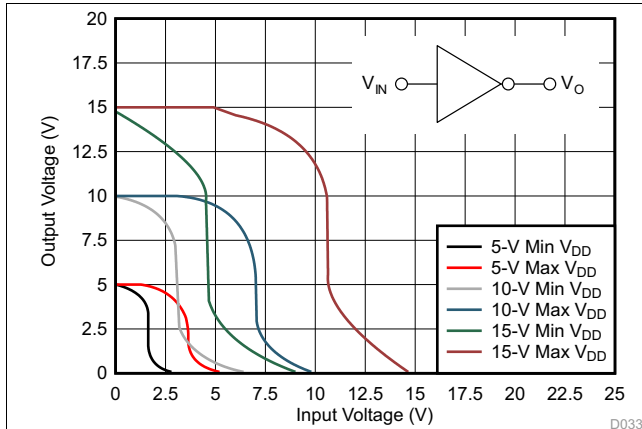

Figure 1. Minimum and Maximum Voltage Transfer Characteristics

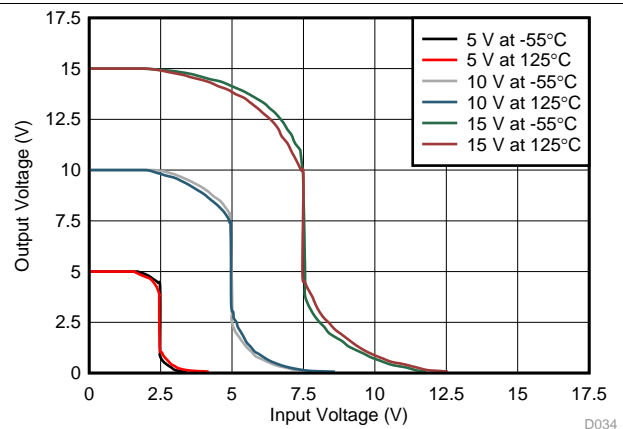

Figure 2. Typical Voltage Transfer Characteristics as a Function of Temperature

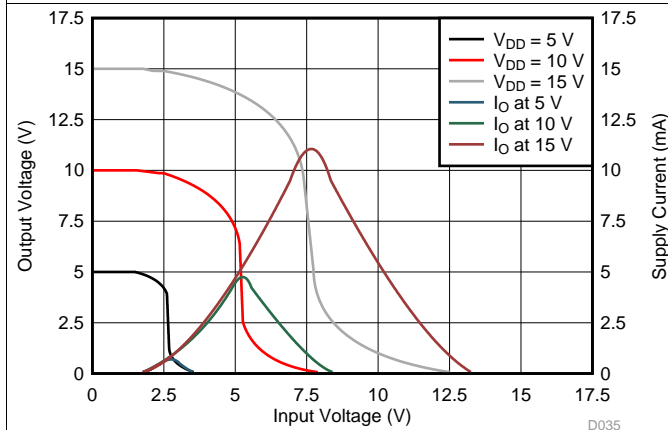

Figure 3. Typical Current and Voltage Transfer Characteristics

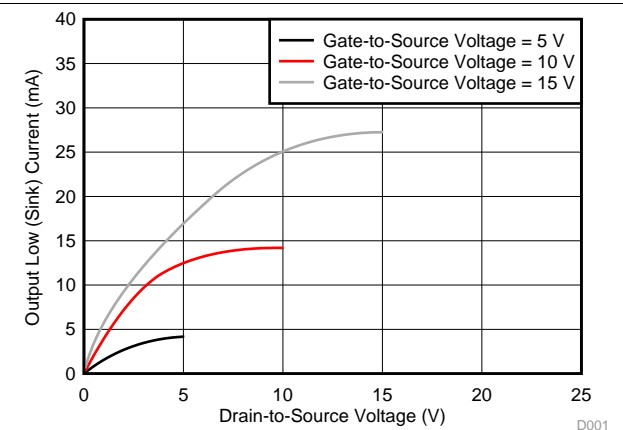

Figure 4. Typical Output Low (Sink) Current Characteristics

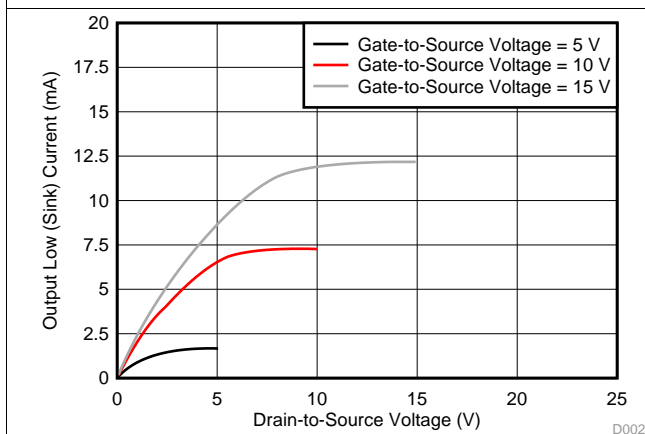

Figure 5. Minimum Output Low (Sink) Current Characteristics

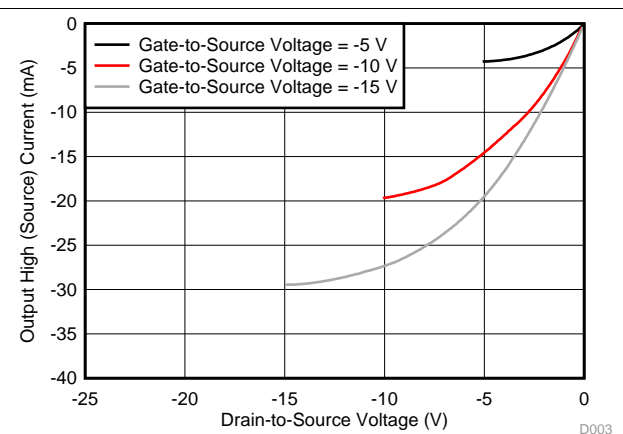
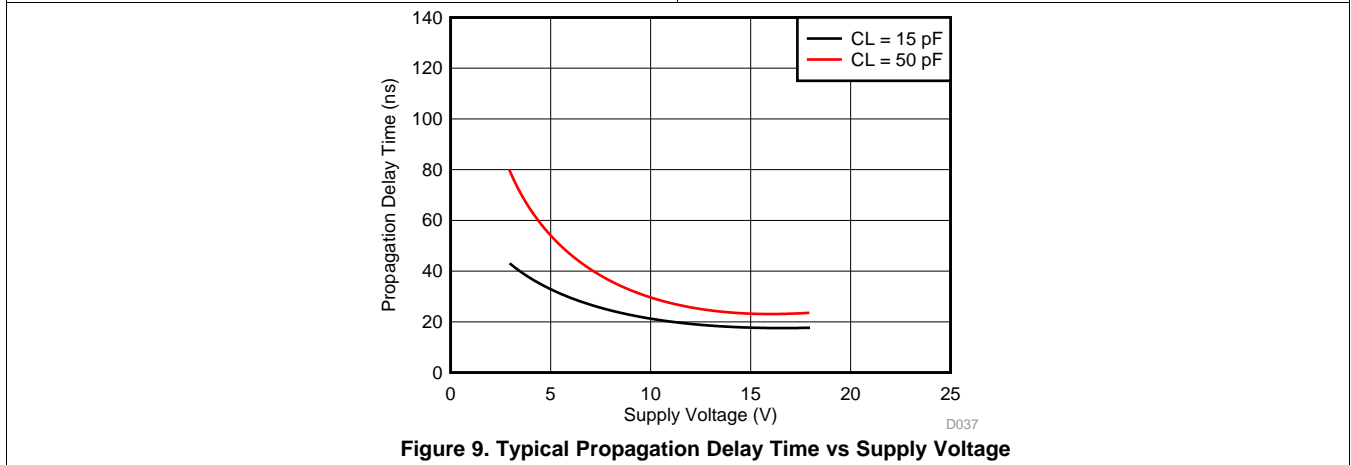
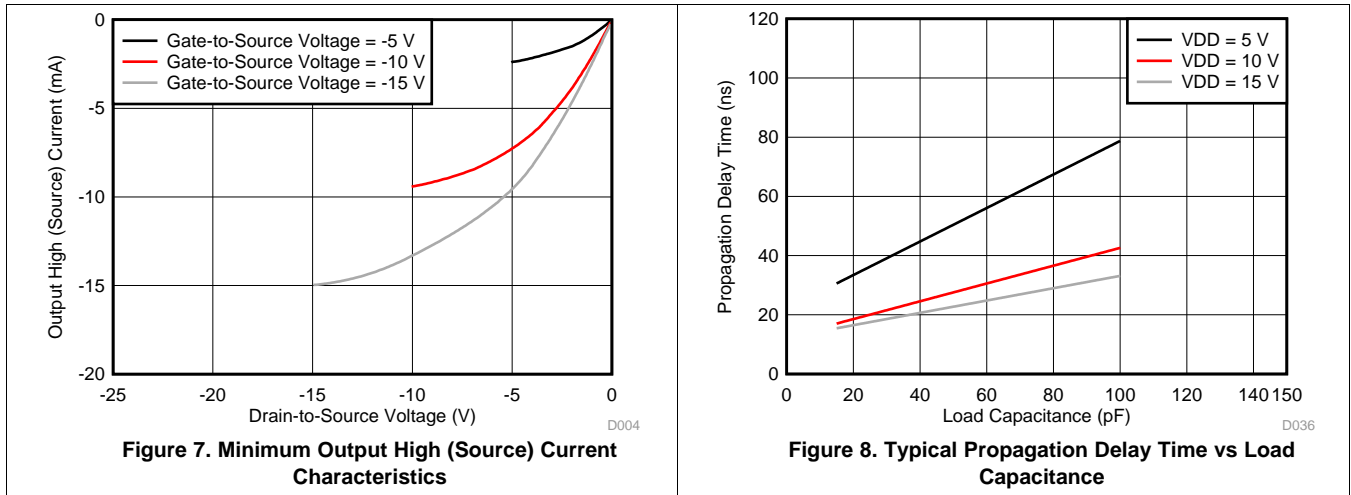

Figure 6. Typical Output High (Source) Current Characteristics

Typical Characteristics (continued)



7 Parameter Measurement Information

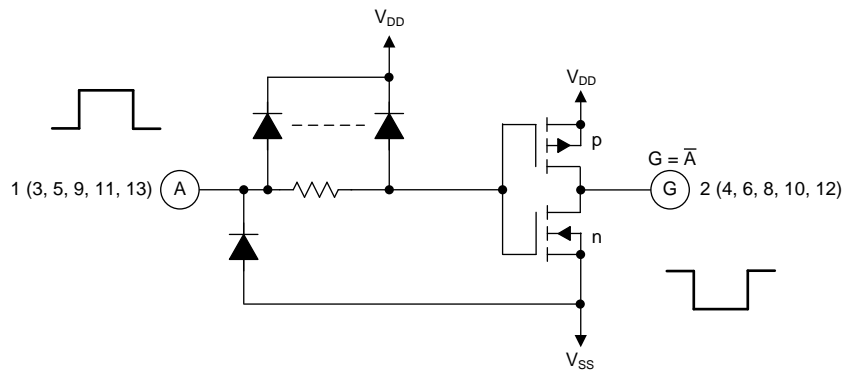
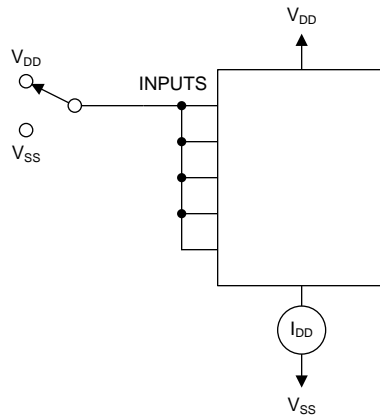
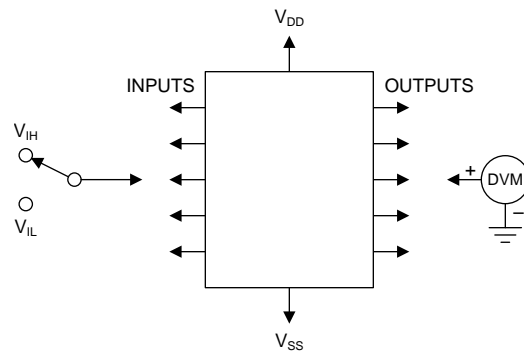

Figure 10. Schematic Diagram of One of Six Identical Inverters



**Figure 11. Quiescent Device Current Test Circuit**



**Figure 12. Noise Immunity Test Circuit**

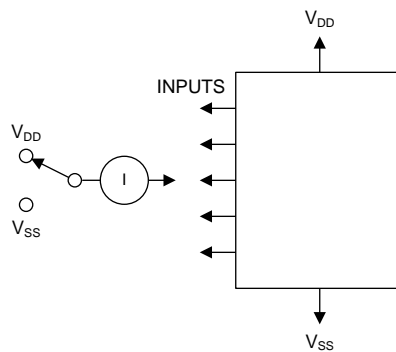

**Figure 13. Input Leakage Current Test Circuit**

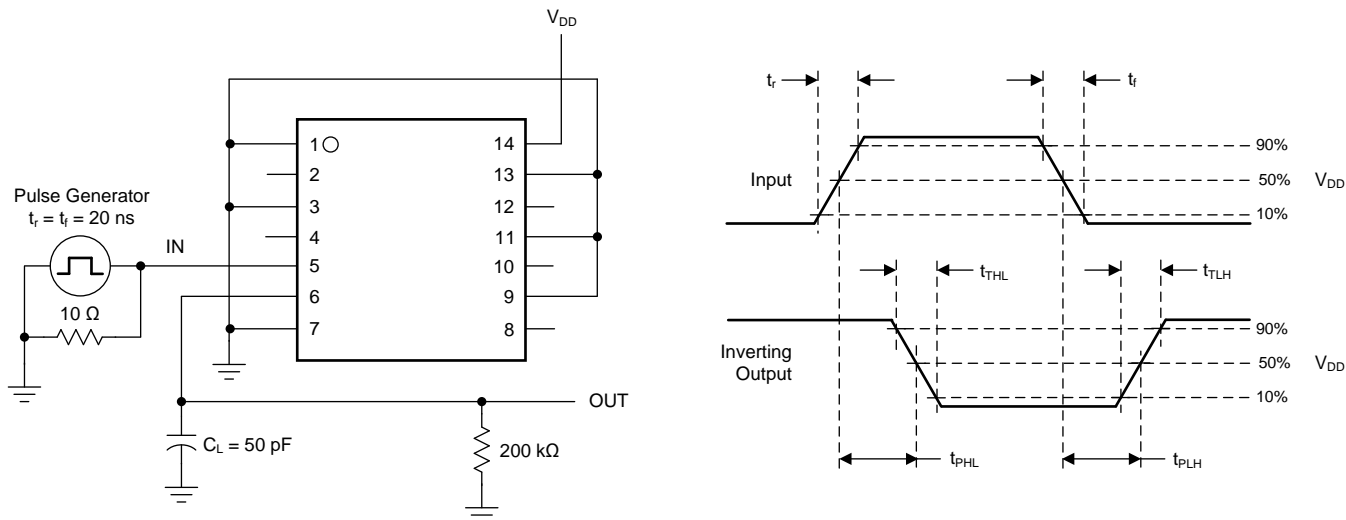

Figure 14. Dynamic Electrical Characteristics Test Circuit and Waveform

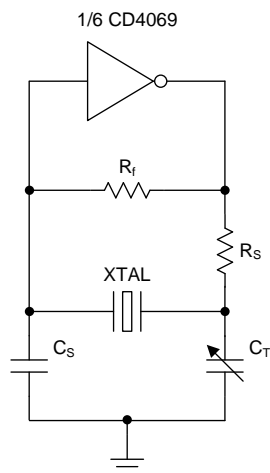

Figure 15. Typical Crystal Oscillator Circuit

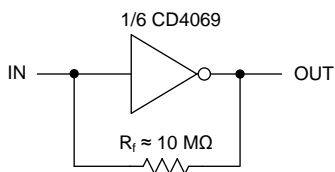

Figure 16. High-Input Impedance Amplifier

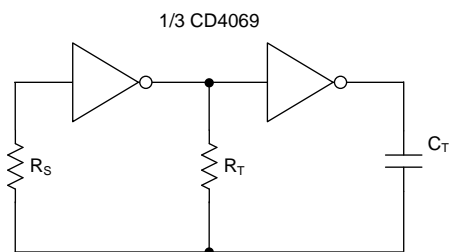
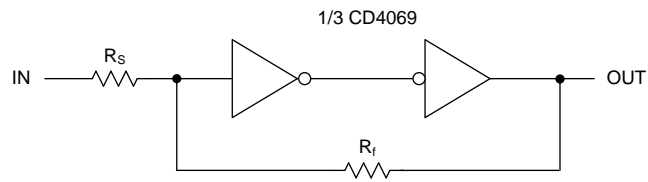

Figure 17. Typical RC Oscillator Circuit



Upper Switching Point :

$$V_P = \frac{R_S + R_f}{R_f} \times \frac{V_{DD}}{2}$$

Lower Switching Point :

$$V_N = \frac{R_f - R_S}{R_f} \times \frac{V_{DD}}{2}$$

$$R_f > R_S$$

**Figure 18. Input Pulse Shaping Circuit**

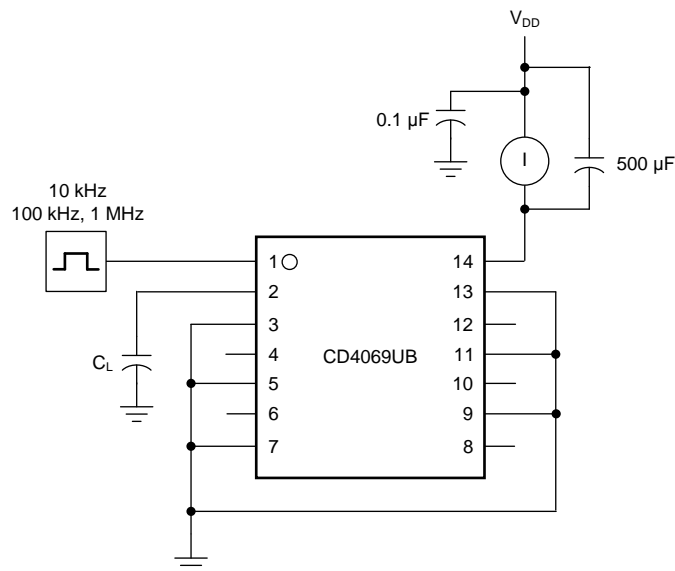

**Figure 19. Dynamic Power Dissipation Test Circuit**

## 8 Detailed Description

### 8.1 Overview

The CD4069UB device has six inverter circuits. The recommended operating range is from 3 V to 18 V. The CD4069UB-series types are supplied in 14-pin hermetic dual-in-line ceramic packages (F3A suffix), 14-pin dual-in-line plastic packages (E suffix), 14-pin small-outline packages (M, MT, M96, and NSR suffixes), and 14-pin thin shrink small-outline packages (PW and PWR suffixes).

### 8.2 Functional Block Diagram

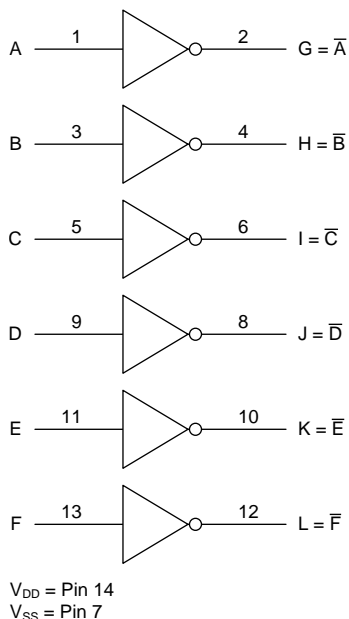

### 8.3 Feature Description

CD4069UB has standardized symmetrical output characteristics and a wide operating voltage range from 3 V to 18 V with quiescent current tested at 20 V. This has a medium operation speed of  $t_{PHL}$ ,  $t_{PLH} = 30$  ns (typical) at 10 V. The operating temperature is from  $-55^{\circ}\text{C}$  to  $125^{\circ}\text{C}$ . CD4069UB meets all requirements of JEDEC tentative standard No. 13B, *Standard Specifications for Description of B Series CMOS Devices*.

### 8.4 Device Functional Modes

Table 1 shows the functional modes for CD4069UB.

Table 1. Function Table

INPUT A, B, C, D, E, F	OUTPUT G, H, I, J, K, L
H	L
L	H

## 9 Application and Implementation

### NOTE

Information in the following applications sections is not part of the TI component specification, and TI does not warrant its accuracy or completeness. TI's customers are responsible for determining suitability of components for their purposes. Customers should validate and test their design implementation to confirm system functionality.

### 9.1 Application Information

The CD4069UB device has a low input current of 1  $\mu\text{A}$  at 18 V over full package-temperature range and 100 nA at 18 V, 25°C. This device has a wide operating voltage range from 3 V to 18 V and used in high voltage applications.

### 9.2 Typical Application

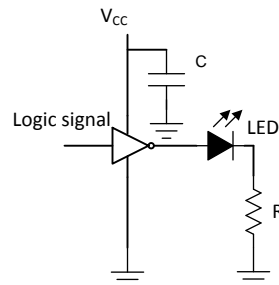

Copyright © 2016,  
Texas Instruments Incorporated

**Figure 20. CD4069UB Application**

#### 9.2.1 Design Requirements

The CD4069UB device is the industry's highest logic inverter operating at 18 V under recommended conditions. The lower drive capabilities makes it suitable for driving light loads like LED and greatly reduces chances of overshoots and undershoots.

#### 9.2.2 Detailed Design Procedure

The recommended input conditions for [Figure 20](#) includes rise time and fall time specifications (see  $\Delta t/\Delta V$  in [Recommended Operating Conditions](#)) and specified high and low levels (see  $V_{IH}$  and  $V_{IL}$  in [Recommended Operating Conditions](#)). Inputs are not overvoltage tolerant and must be below  $V_{CC}$  level because of the presence of input clamp diodes to  $V_{CC}$ .

The recommended output condition for the CD4069UB application includes specific load currents. Load currents must be limited so as to not exceed the total power (continuous current through  $V_{CC}$  or GND) for the device. These limits are located in the [Absolute Maximum Ratings](#). Outputs must not be pulled above  $V_{CC}$ .

Typical Application (continued)

9.2.3 Application Curves

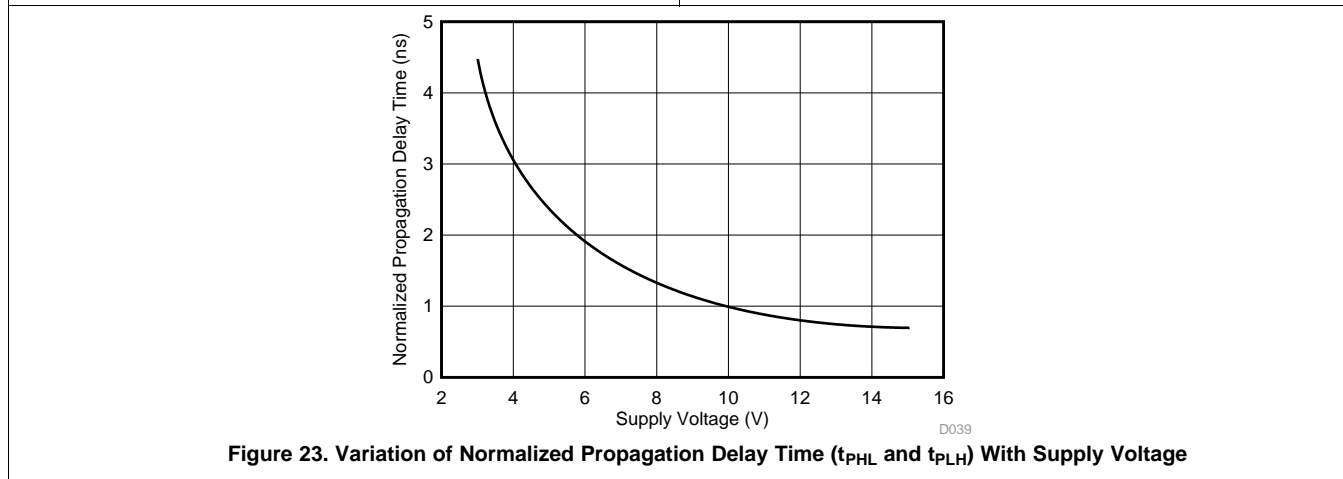
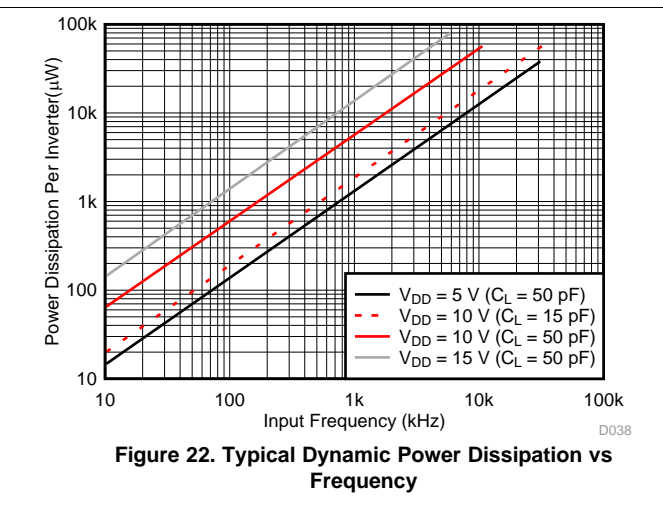
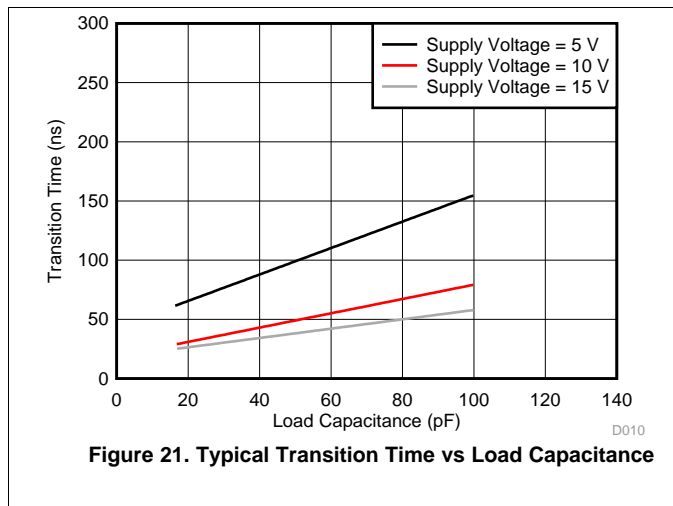

## 10 Power Supply Recommendations

The power supply can be any voltage between the minimum and maximum supply voltage rating located in [Recommended Operating Conditions](#).

Each  $V_{CC}$  pin must have a good bypass capacitor to prevent power disturbance. For devices with a single supply, TI recommends a 0.1- $\mu\text{F}$  capacitor. If there are multiple  $V_{CC}$  pins, then TI recommends a 0.01- $\mu\text{F}$  or 0.022- $\mu\text{F}$  capacitor for each power pin. It is acceptable to parallel multiple bypass capacitors to reject different frequencies of noise. 0.1- $\mu\text{F}$  and 1- $\mu\text{F}$  capacitors are commonly used in parallel. The bypass capacitor must be installed as close to the power pin as possible for best results.

## 11 Layout

### 11.1 Layout Guidelines

When using multiple bit logic devices, inputs must never float.

In many cases, digital logic device functions or parts of these functions are unused (for example, when only two inputs of a triple-input and gate are used, or only 3 of the 4 buffer gates are used). Such input pins must not be left unconnected because the undefined voltages at the outside connections result in undefined operational states. This rule must be observed under all circumstances specified in the next paragraph.

All unused inputs of digital logic devices must be connected to a high or low bias to prevent them from floating. See the application note, [Implications of Slow or Floating CMOS Inputs \(SCBA004\)](#), for more information on the effects of floating inputs. The logic level must apply to any particular unused input depending on the function of the device. Generally, they are tied to GND or  $V_{CC}$  (whichever is convenient).

### 11.2 Layout Example

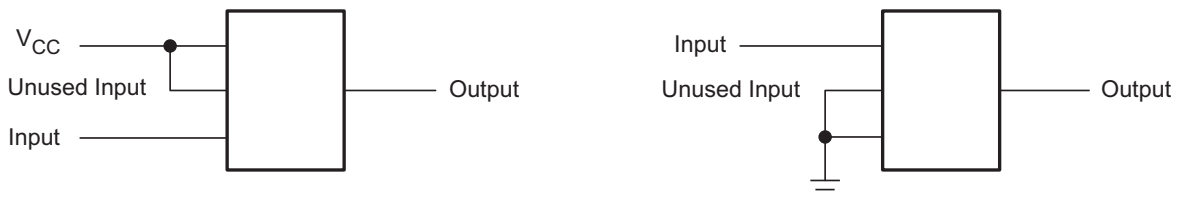

## 12 Device and Documentation Support

### 12.1 Device Support

#### 12.1.1 Third-Party Products Disclaimer

TI'S PUBLICATION OF INFORMATION REGARDING THIRD-PARTY PRODUCTS OR SERVICES DOES NOT CONSTITUTE AN ENDORSEMENT REGARDING THE SUITABILITY OF SUCH PRODUCTS OR SERVICES OR A WARRANTY, REPRESENTATION OR ENDORSEMENT OF SUCH PRODUCTS OR SERVICES, EITHER ALONE OR IN COMBINATION WITH ANY TI PRODUCT OR SERVICE.

### 12.2 Documentation Support

#### 12.2.1 Related Documentation

For related documentation see the following:

- *Implications of Slow or Floating CMOS Inputs*, [SCBA004](#)

### 12.3 Community Resource

The following links connect to TI community resources. Linked contents are provided "AS IS" by the respective contributors. They do not constitute TI specifications and do not necessarily reflect TI's views; see TI's [Terms of Use](#).

**TI E2E™ Online Community** *TI's Engineer-to-Engineer (E2E) Community*. Created to foster collaboration among engineers. At [e2e.ti.com](#), you can ask questions, share knowledge, explore ideas and help solve problems with fellow engineers.

**Design Support** *TI's Design Support* Quickly find helpful E2E forums along with design support tools and contact information for technical support.

### 12.4 Trademarks

E2E is a trademark of Texas Instruments.  
All other trademarks are the property of their respective owners.

### 12.5 Electrostatic Discharge Caution



These devices have limited built-in ESD protection. The leads should be shorted together or the device placed in conductive foam during storage or handling to prevent electrostatic damage to the MOS gates.

### 12.6 Glossary

[SLYZ022](#) — *TI Glossary*.

This glossary lists and explains terms, acronyms, and definitions.

## 13 Mechanical, Packaging, and Orderable Information

The following pages include mechanical, packaging, and orderable information. This information is the most current data available for the designated devices. This data is subject to change without notice and revision of this document. For browser-based versions of this data sheet, refer to the left-hand navigation.

**PACKAGING INFORMATION**

Orderable Device	Status (1)	Package Type	Package Drawing	Pins	Package Qty	Eco Plan (2)	Lead/Ball Finish (6)	MSL Peak Temp (3)	Op Temp (°C)	Device Marking (4/5)	Samples
CD4069UBE	ACTIVE	PDIP	N	14	25	Green (RoHS & no Sb/Br)	CU NIPDAU	N / A for Pkg Type	-55 to 125	CD4069UBE	<a href="#">Samples</a>
CD4069UBEE4	ACTIVE	PDIP	N	14	25	Green (RoHS & no Sb/Br)	CU NIPDAU	N / A for Pkg Type	-55 to 125	CD4069UBE	<a href="#">Samples</a>
CD4069UBF	ACTIVE	CDIP	J	14	1	TBD	A42	N / A for Pkg Type	-55 to 125	CD4069UBF	<a href="#">Samples</a>
CD4069UBF3A	ACTIVE	CDIP	J	14	1	TBD	A42	N / A for Pkg Type	-55 to 125	CD4069UBF3A	<a href="#">Samples</a>
CD4069UBM	ACTIVE	SOIC	D	14	50	Green (RoHS & no Sb/Br)	CU NIPDAU	Level-1-260C-UNLIM	-55 to 125	CD4069UBM	<a href="#">Samples</a>
CD4069UBM96	ACTIVE	SOIC	D	14	2500	Green (RoHS & no Sb/Br)	CU NIPDAU   CU SN	Level-1-260C-UNLIM	-55 to 125	CD4069UBM	<a href="#">Samples</a>
CD4069UBMT	ACTIVE	SOIC	D	14	250	Green (RoHS & no Sb/Br)	CU NIPDAU	Level-1-260C-UNLIM	-55 to 125	CD4069UBM	<a href="#">Samples</a>
CD4069UBNSR	ACTIVE	SO	NS	14	2000	Green (RoHS & no Sb/Br)	CU NIPDAU	Level-1-260C-UNLIM	-55 to 125	CD4069UB	<a href="#">Samples</a>
CD4069UBPW	ACTIVE	TSSOP	PW	14	90	Green (RoHS & no Sb/Br)	CU NIPDAU	Level-1-260C-UNLIM	-55 to 125	CM069UB	<a href="#">Samples</a>
CD4069UBPWG4	ACTIVE	TSSOP	PW	14	90	Green (RoHS & no Sb/Br)	CU NIPDAU	Level-1-260C-UNLIM	-55 to 125	CM069UB	<a href="#">Samples</a>
CD4069UBPWR	ACTIVE	TSSOP	PW	14	2000	Green (RoHS & no Sb/Br)	CU NIPDAU   CU SN	Level-1-260C-UNLIM	-55 to 125	CM069UB	<a href="#">Samples</a>
JM38510/17401BCA	ACTIVE	CDIP	J	14	1	TBD	A42	N / A for Pkg Type	-55 to 125	JM38510/ 17401BCA	<a href="#">Samples</a>
M38510/17401BCA	ACTIVE	CDIP	J	14	1	TBD	A42	N / A for Pkg Type	-55 to 125	JM38510/ 17401BCA	<a href="#">Samples</a>

(1) The marketing status values are defined as follows:

**ACTIVE:** Product device recommended for new designs.

**LIFEBUY:** TI has announced that the device will be discontinued, and a lifetime-buy period is in effect.

**NRND:** Not recommended for new designs. Device is in production to support existing customers, but TI does not recommend using this part in a new design.

**PREVIEW:** Device has been announced but is not in production. Samples may or may not be available.

**OBsolete:** TI has discontinued the production of the device.

(2) **RoHS:** TI defines "RoHS" to mean semiconductor products that are compliant with the current EU RoHS requirements for all 10 RoHS substances, including the requirement that RoHS substance do not exceed 0.1% by weight in homogeneous materials. Where designed to be soldered at high temperatures, "RoHS" products are suitable for use in specified lead-free processes. TI may reference these types of products as "Pb-Free".

**RoHS Exempt:** TI defines "RoHS Exempt" to mean products that contain lead but are compliant with EU RoHS pursuant to a specific EU RoHS exemption.

**Green:** TI defines "Green" to mean the content of Chlorine (Cl) and Bromine (Br) based flame retardants meet JS709B low halogen requirements of  $\leq 1000$ ppm threshold. Antimony trioxide based flame retardants must also meet the  $\leq 1000$ ppm threshold requirement.

(3) **MSL, Peak Temp.** - The Moisture Sensitivity Level rating according to the JEDEC industry standard classifications, and peak solder temperature.

(4) There may be additional marking, which relates to the logo, the lot trace code information, or the environmental category on the device.

(5) Multiple Device Markings will be inside parentheses. Only one Device Marking contained in parentheses and separated by a "~" will appear on a device. If a line is indented then it is a continuation of the previous line and the two combined represent the entire Device Marking for that device.

(6) **Lead/Ball Finish** - Orderable Devices may have multiple material finish options. Finish options are separated by a vertical ruled line. Lead/Ball Finish values may wrap to two lines if the finish value exceeds the maximum column width.

**Important Information and Disclaimer:** The information provided on this page represents TI's knowledge and belief as of the date that it is provided. TI bases its knowledge and belief on information provided by third parties, and makes no representation or warranty as to the accuracy of such information. Efforts are underway to better integrate information from third parties. TI has taken and continues to take reasonable steps to provide representative and accurate information but may not have conducted destructive testing or chemical analysis on incoming materials and chemicals. TI and TI suppliers consider certain information to be proprietary, and thus CAS numbers and other limited information may not be available for release.

In no event shall TI's liability arising out of such information exceed the total purchase price of the TI part(s) at issue in this document sold by TI to Customer on an annual basis.

**OTHER QUALIFIED VERSIONS OF CD4069UB, CD4069UB-MIL :**

- Catalog: [CD4069UB](#)
- Military: [CD4069UB-MIL](#)

**NOTE: Qualified Version Definitions:**

- Catalog - TI's standard catalog product
- Military - QML certified for Military and Defense Applications

**TAPE AND REEL INFORMATION**

**QUADRANT ASSIGNMENTS FOR PIN 1 ORIENTATION IN TAPE**

\*All dimensions are nominal

Device	Package Type	Package Drawing	Pins	SPQ	Reel Diameter (mm)	Reel Width W1 (mm)	A0 (mm)	B0 (mm)	K0 (mm)	P1 (mm)	W (mm)	Pin1 Quadrant
CD4069UBM96	SOIC	D	14	2500	330.0	16.4	6.5	9.0	2.1	8.0	16.0	Q1
CD4069UBM96	SOIC	D	14	2500	330.0	16.8	6.5	9.5	2.1	8.0	16.0	Q1
CD4069UBMT	SOIC	D	14	250	330.0	16.4	6.5	9.0	2.1	8.0	16.0	Q1
CD4069UBNSR	SO	NS	14	2000	330.0	16.4	8.2	10.5	2.5	12.0	16.0	Q1
CD4069UBPWR	TSSOP	PW	14	2000	330.0	12.4	6.9	5.6	1.6	8.0	12.0	Q1
CD4069UBPWR	TSSOP	PW	14	2000	330.0	12.4	6.9	5.6	1.6	8.0	12.0	Q1

**TAPE AND REEL BOX DIMENSIONS**

\*All dimensions are nominal

Device	Package Type	Package Drawing	Pins	SPQ	Length (mm)	Width (mm)	Height (mm)
CD4069UBM96	SOIC	D	14	2500	367.0	367.0	38.0
CD4069UBM96	SOIC	D	14	2500	364.0	364.0	27.0
CD4069UBMT	SOIC	D	14	250	210.0	185.0	35.0
CD4069UBNSR	SO	NS	14	2000	367.0	367.0	38.0
CD4069UBPWR	TSSOP	PW	14	2000	367.0	367.0	35.0
CD4069UBPWR	TSSOP	PW	14	2000	364.0	364.0	27.0

# MECHANICAL DATA

NS (R-PDSO-G\*\*)

PLASTIC SMALL-OUTLINE PACKAGE

14-PINS SHOWN



- NOTES:
- A. All linear dimensions are in millimeters.
  - B. This drawing is subject to change without notice.
  - C. Body dimensions do not include mold flash or protrusion, not to exceed 0,15.

J 14

**GENERIC PACKAGE VIEW**  
**CDIP - 5.08 mm max height**  
CERAMIC DUAL IN LINE PACKAGE



Images above are just a representation of the package family, actual package may vary.  
Refer to the product data sheet for package details.

4040083-5/G

J0014A



# PACKAGE OUTLINE

CDIP - 5.08 mm max height

CERAMIC DUAL IN LINE PACKAGE



4214771/A 05/2017

NOTES:

1. All controlling linear dimensions are in inches. Dimensions in brackets are in millimeters. Any dimension in brackets or parenthesis are for reference only. Dimensioning and tolerancing per ASME Y14.5M.
2. This drawing is subject to change without notice.
3. This package is hermetically sealed with a ceramic lid using glass frit.
4. Index point is provided on cap for terminal identification only and on press ceramic glass frit seal only.
5. Falls within MIL-STD-1835 and GDIP1-T14.

# EXAMPLE BOARD LAYOUT

J0014A

CDIP - 5.08 mm max height

CERAMIC DUAL IN LINE PACKAGE

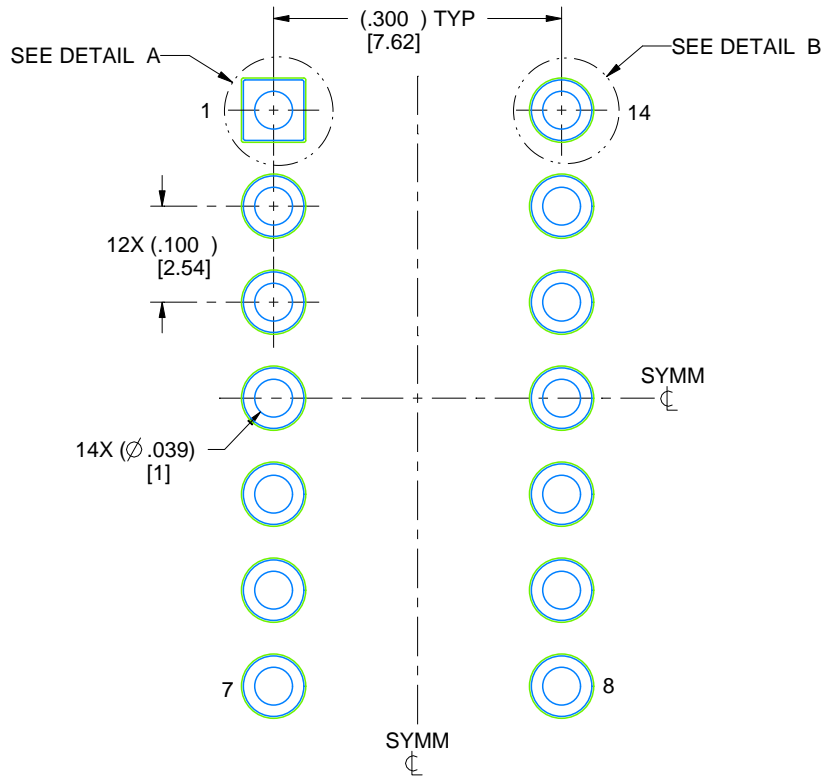

LAND PATTERN EXAMPLE  
NON-SOLDER MASK DEFINED  
SCALE: 5X



4214771/A 05/2017



D (R-PDSO-G14)

PLASTIC SMALL OUTLINE

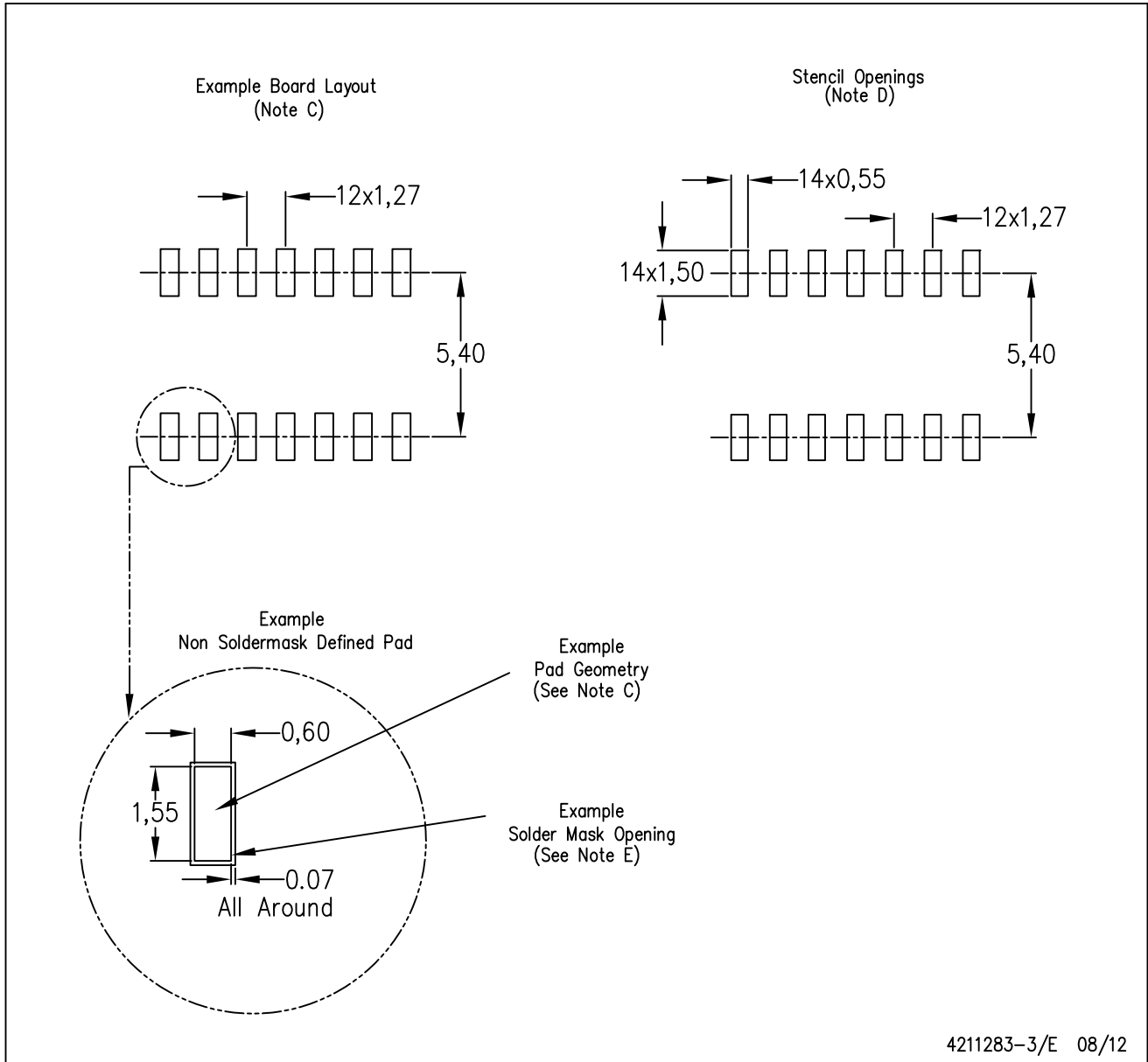

- NOTES:
- All linear dimensions are in millimeters.
  - This drawing is subject to change without notice.
  - Publication IPC-7351 is recommended for alternate designs.
  - Laser cutting apertures with trapezoidal walls and also rounding corners will offer better paste release. Customers should contact their board assembly site for stencil design recommendations. Refer to IPC-7525 for other stencil recommendations.
  - Customers should contact their board fabrication site for solder mask tolerances between and around signal pads.

PW (R-PDSO-G14)

PLASTIC SMALL OUTLINE



4040064-3/G 02/11

- NOTES:
- A. All linear dimensions are in millimeters. Dimensioning and tolerancing per ASME Y14.5M-1994.
  - B. This drawing is subject to change without notice.
  - C. Body length does not include mold flash, protrusions, or gate burrs. Mold flash, protrusions, or gate burrs shall not exceed 0,15 each side.
  - D. Body width does not include interlead flash. Interlead flash shall not exceed 0,25 each side.
  - E. Falls within JEDEC MO-153

PW (R-PDSO-G14)

PLASTIC SMALL OUTLINE

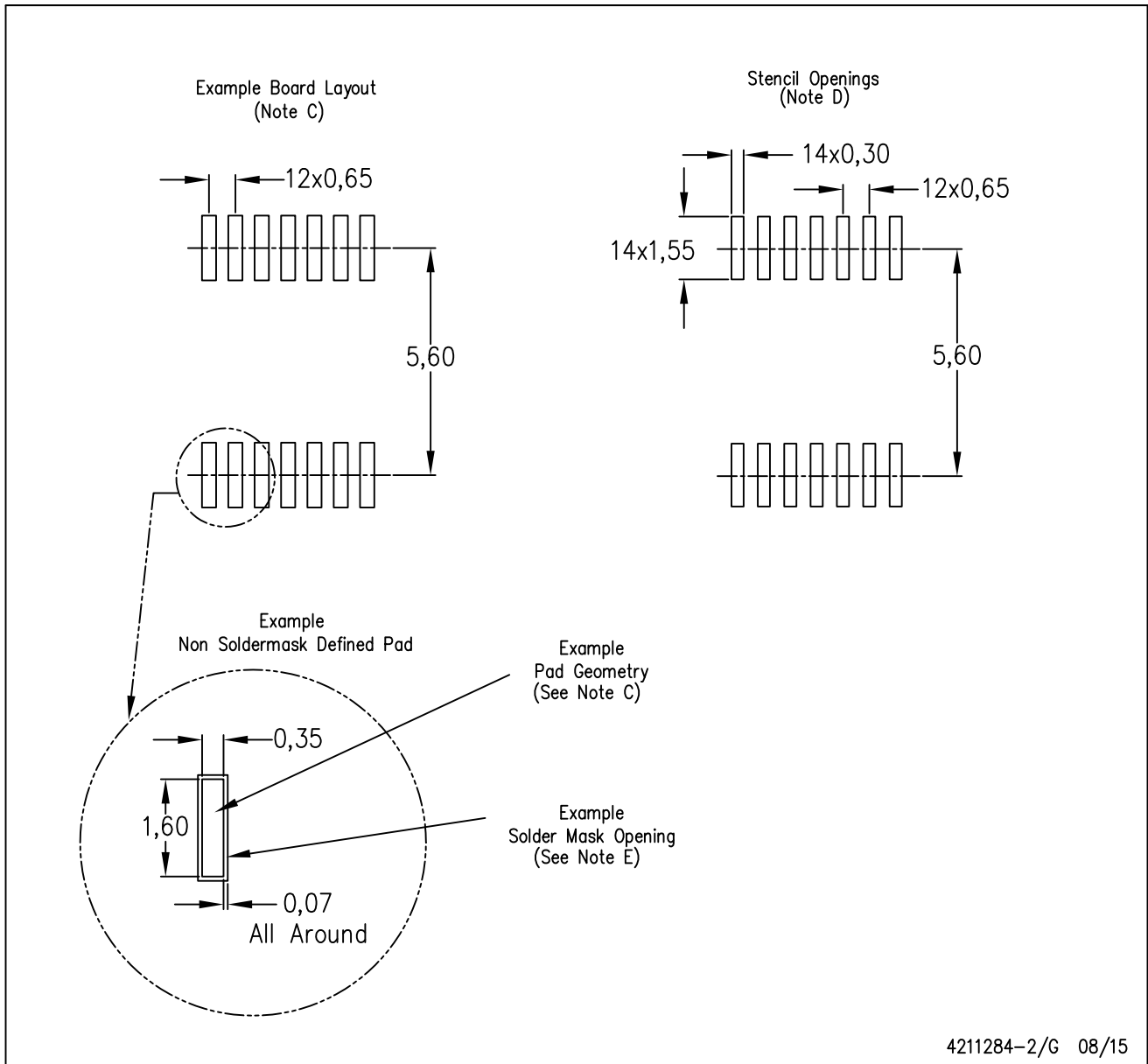

4211284-2/G 08/15

- NOTES:
- A. All linear dimensions are in millimeters.
  - B. This drawing is subject to change without notice.
  - C. Publication IPC-7351 is recommended for alternate designs.
  - D. Laser cutting apertures with trapezoidal walls and also rounding corners will offer better paste release. Customers should contact their board assembly site for stencil design recommendations. Refer to IPC-7525 for other stencil recommendations.
  - E. Customers should contact their board fabrication site for solder mask tolerances between and around signal pads.



## IMPORTANT NOTICE AND DISCLAIMER

TI PROVIDES TECHNICAL AND RELIABILITY DATA (INCLUDING DATASHEETS), DESIGN RESOURCES (INCLUDING REFERENCE DESIGNS), APPLICATION OR OTHER DESIGN ADVICE, WEB TOOLS, SAFETY INFORMATION, AND OTHER RESOURCES "AS IS" AND WITH ALL FAULTS, AND DISCLAIMS ALL WARRANTIES, EXPRESS AND IMPLIED, INCLUDING WITHOUT LIMITATION ANY IMPLIED WARRANTIES OF MERCHANTABILITY, FITNESS FOR A PARTICULAR PURPOSE OR NON-INFRINGEMENT OF THIRD PARTY INTELLECTUAL PROPERTY RIGHTS.

These resources are intended for skilled developers designing with TI products. You are solely responsible for (1) selecting the appropriate TI products for your application, (2) designing, validating and testing your application, and (3) ensuring your application meets applicable standards, and any other safety, security, or other requirements. These resources are subject to change without notice. TI grants you permission to use these resources only for development of an application that uses the TI products described in the resource. Other reproduction and display of these resources is prohibited. No license is granted to any other TI intellectual property right or to any third party intellectual property right. TI disclaims responsibility for, and you will fully indemnify TI and its representatives against, any claims, damages, costs, losses, and liabilities arising out of your use of these resources.

TI's products are provided subject to TI's Terms of Sale ([www.ti.com/legal/termsofsale.html](http://www.ti.com/legal/termsofsale.html)) or other applicable terms available either on [ti.com](http://ti.com) or provided in conjunction with such TI products. TI's provision of these resources does not expand or otherwise alter TI's applicable warranties or warranty disclaimers for TI products.

Mailing Address: Texas Instruments, Post Office Box 655303, Dallas, Texas 75265  
Copyright © 2019, Texas Instruments Incorporated

## Looking for pricing, stock, or lifecycle information?

Click below to explore more details on WIN SOURCE:

 [View CD4069UBPWR on WIN SOURCE](#)

 [Texas Instruments](#) Information

## Optimize Your Supply Chain with WIN SOURCE Solutions

-  Global Sourcing Solution
-  Obsolete Management
-  Cost Control Management
-  Shortage Management
-  Alternative Solution
-  Excess Inventory Management