



**THE DATASHEET OF
MAX5159CEE**





Low-Power, Dual, 10-Bit, Voltage-Output DACs with Serial Interface

General Description

The MAX5158/MAX5159 low-power, serial, voltage-output, dual, 10-bit digital-to-analog converters (DACs) consume only 500 μ A from a single +5V (MAX5158) or +3V (MAX5159) supply. These devices feature Rail-to-Rail[®] output swing and are available in a space-saving 16-pin QSOP package. To maximize dynamic range, the DAC output amplifiers are configured with an internal gain of +2V/V.

The 3-wire serial interface is SPI[™]/QSPI[™] and Microwire[™] compatible. Each DAC has a double-buffered input organized as an input register followed by a DAC register, which allows the input and DAC registers to be updated independently or simultaneously with a 16-bit serial word. Additional features include a 2 μ A programmable shutdown, hardware-shutdown lockout, a separate reference-voltage input for each DAC that accepts AC and DC signals, and an active-low clear input (\overline{CL}) that resets all registers and DACs to zero. The MAX5158/MAX5159 provide a programmable logic pin for added functionality and a serial-data output pin for daisy chaining.

Applications

Digital Offset and Gain Adjustment
 μ P-Controlled Systems
 Motion Control
 Remote Industrial Controls

Features

- ◆ 10-Bit Dual DAC with Internal Gain of +2V/V
- ◆ Rail-to-Rail Output Swing
- ◆ 8 μ s Settling Time
- ◆ Single-Supply Operation: +5V (MAX5158)
+3V (MAX5159)
- ◆ Low Quiescent Current: 500 μ A (normal operation)
2 μ A (shutdown mode)
- ◆ SPI/QSPI and Microwire Compatible
- ◆ Available in Space-Saving 16-Pin QSOP Package
- ◆ Power-On Reset Clears Registers and DACs to Zero
- ◆ Adjustable Output Offset

Ordering Information

PART	TEMP. RANGE	PIN-PACKAGE
MAX5158CPE	0°C to +70°C	16 Plastic DIP
MAX5158CEE	0°C to +70°C	16 QSOP
MAX5158EPE	-40°C to +85°C	16 Plastic DIP
MAX5158EEE	-40°C to +85°C	16 QSOP
MAX5158MJE	-55°C to +125°C	16 CERDIP*

Ordering Information continued at end of data sheet.
 *Contact factory for availability.

Functional Diagram

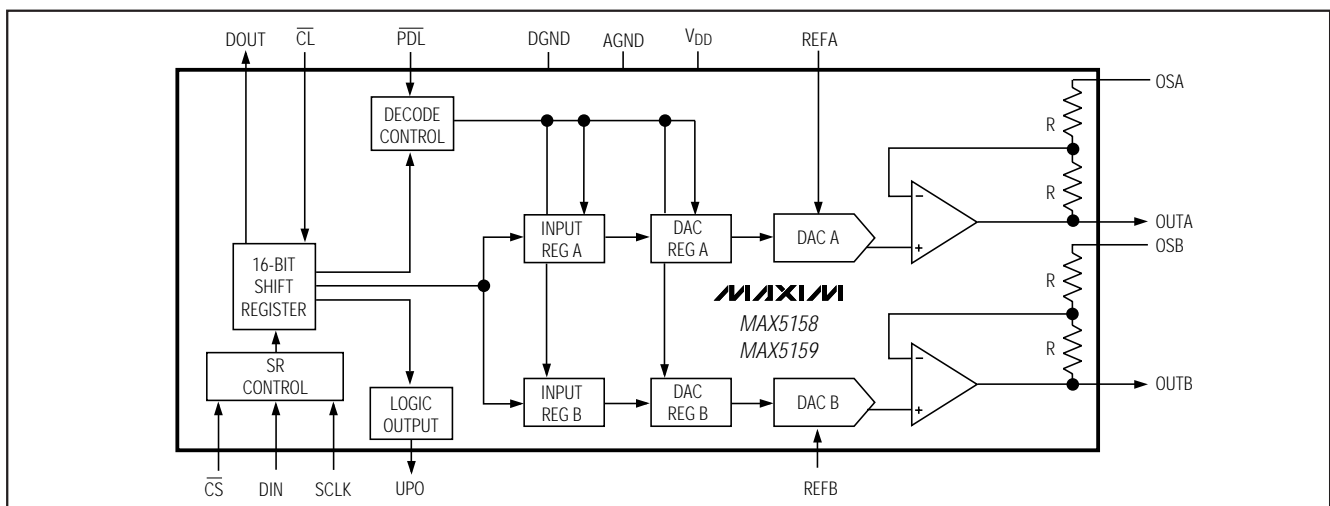

Rail-to-Rail is a registered trademark of Nippon Motorola Ltd. Microwire is a trademark of National Semiconductor Corp.
 SPI and QSPI are trademarks of Motorola, Inc.



Maxim Integrated Products 1

For free samples & the latest literature: <http://www.maxim-ic.com>, or phone 1-800-998-8800
 For small orders, phone 408-737-7600 ext. 3468.

MAX5158/MAX5159

Low-Power, Dual, 10-Bit Voltage-Output DACs with Serial Interface

ABSOLUTE MAXIMUM RATINGS

V _{DD} to AGND	-0.3V to +6V	Continuous Power Dissipation (T _A = +70°C)	
V _{DD} to DGND	-0.3V to +6V	Plastic DIP (derate 10.5mW/°C above +70°C)	842mW
AGND to DGND	±0.3V	QSOP (derate 8.30mW/°C above +70°C)	667mW
OSA, OSB to AGND	(AGND - 4V) to (V _{DD} + 0.3V)	CERDIP (derate 10.00mW/°C above +70°C)	800mW
REF ₋ , OUT ₋ to AGND	-0.3V to (V _{DD} + 0.3V)	Operating Temperature Ranges	
Digital Inputs (SCLK, DIN, CS, CL, PDL) to DGND	(-0.3V to +6V)	MAX515 ₋ _C_E	0°C to +70°C
Digital Outputs (DOUT, UPO) to DGND	-0.3V to (V _{DD} + 0.3V)	MAX515 ₋ _E_E	-40°C to +85°C
Maximum Current into Any Pin	±20mA	MAX515 ₋ _MJE	-55°C to +125°C
		Storage Temperature Range	-65°C to +160°C
		Lead Temperature (soldering, 10sec)	+300°C

Stresses beyond those listed under "Absolute Maximum Ratings" may cause permanent damage to the device. These are stress ratings only, and functional operation of the device at these or any other conditions beyond those indicated in the operational sections of the specifications is not implied. Exposure to absolute maximum rating conditions for extended periods may affect device reliability.

ELECTRICAL CHARACTERISTICS—MAX5158

(V_{DD} = +5V ±10%, V_{REFA} = V_{REFB} = 2.048V, R_L = 10kΩ, C_L = 100pF, T_A = T_{MIN} to T_{MAX}, unless otherwise noted. Typical values are at T_A = +25°C (OS₋ tied to AGND for a gain of +2V/V).)

PARAMETER	SYMBOL	CONDITIONS	MIN	TYP	MAX	UNITS
STATIC PERFORMANCE						
Resolution			10			Bits
Integral Nonlinearity	INL	(Note 1)			±1	LSB
Differential Nonlinearity	DNL	Guaranteed monotonic			±1	LSB
Offset Error	V _{OS}	Code = 2			±6	mV
Offset Tempco	TCV _{OS}	Normalized to 2.048V		4		ppm/°C
Gain Error				-0.1	1	LSB
Gain-Error Tempco		Normalized to 2.048V		4		ppm/°C
V _{DD} Power-Supply Rejection Ratio	PSRR	2.7V ≤ V _{DD} ≤ 5.5V		20	260	μV/V
REFERENCE INPUT						
Reference Input Range	REF		0		V _{DD} - 1.4	V
Reference Input Resistance	R _{REF}	Minimum with code 1558 hex	18	25		kΩ
MULTIPLYING-MODE PERFORMANCE						
Reference 3dB Bandwidth		Input code = 1FF8 hex, V _{REF-} = 0.67Vp-p at 0.75V _{DC}		300		kHz
Reference Feedthrough		Input code = 0000 hex, V _{REF-} = (V _{DD} - 1.4 Vp-p) at 1kHz		-82		dB
Signal-to-Noise plus Distortion Ratio	SINAD	Input code = 1FF8 hex, V _{REF-} = 1Vp-p at 1.25V _{DC} , f = 25kHz		75		dB
DIGITAL INPUTS						
Input High Voltage	V _{IH}	CL, PDL, CS, DIN, SCLK	3			V
Input Low Voltage	V _{IL}	CL, PDL, CS, DIN, SCLK			0.8	V
Input Hysteresis	V _{HYS}			200		mV
Input Leakage Current	I _{IN}	V _{IN} = 0V to V _{DD}		0.001	±1	μA
Input Capacitance	C _{IN}			8		pF

Low-Power, Dual, 10-Bit, Voltage-Output DACs with Serial Interface

MAX5158/MAX5159

ELECTRICAL CHARACTERISTICS—MAX5158 (continued)

($V_{DD} = +5V \pm 10\%$, $V_{REFA} = V_{REFB} = 2.048V$, $R_L = 10k\Omega$, $C_L = 100pF$, $T_A = T_{MIN}$ to T_{MAX} , unless otherwise noted. Typical values are at $T_A = +25^\circ C$ (OS_{-} tied to AGND for a gain of $+2V/V$.)

PARAMETER	SYMBOL	CONDITIONS	MIN	TYP	MAX	UNITS
DIGITAL OUTPUTS (DOUT, UPO)						
Output High Voltage	V_{OH}	$I_{SOURCE} = 2mA$	$V_{DD} - 0.5$			V
Output Low Voltage	V_{OL}	$I_{SINK} = 2mA$		0.13	0.4	V
DYNAMIC PERFORMANCE						
Voltage Output Slew Rate	SR			0.75		V/ μs
Output Settling Time		To 1/2LSB of full-scale, $V_{STEP} = 4V$		8		μs
Output Voltage Swing		Rail-to-rail (Note 2)		0 to V_{DD}		V
OSA or OSB Input Resistance	$R_{OS_{-}}$		24	34		$k\Omega$
Time Required to Exit Shutdown				25		μs
Digital Feedthrough		$\overline{CS} = V_{DD}$, $f_{DIN} = 100kHz$, $V_{SCLK} = 5Vp-p$		5		nV-s
Digital Crosstalk				5		nV-s
POWER SUPPLIES						
Positive Supply Voltage	V_{DD}		4.5		5.5	V
Power-Supply Current	I_{DD}	(Note 3)		0.5	0.65	mA
Power-Supply Current in Shutdown	$I_{DD(SHDN)}$	(Note 3)		2	10	μA
Reference Current in Shutdown				0	± 1	μA
TIMING CHARACTERISTICS						
SCLK Clock Period	t_{CP}	(Note 4)	100			ns
SCLK Pulse Width High	t_{CH}		40			ns
SCLK Pulse Width Low	t_{CL}		40			ns
\overline{CS} Fall to SCLK Rise Setup Time	t_{CSS}		40			ns
SCLK Rise to \overline{CS} Rise Hold Time	t_{CSH}		0			ns
SDI Setup Time	t_{DS}		40			ns
SDI Hold Time	t_{DH}		0			ns
SCLK Rise to DOUT Valid Propagation Delay	t_{DO1}	$C_{LOAD} = 200pF$			80	ns
SCLK Fall to DOUT Valid Propagation Delay	t_{DO2}	$C_{LOAD} = 200pF$			80	ns
SCLK Rise to \overline{CS} Fall Delay	t_{CS0}		10			ns
\overline{CS} Rise to SCLK Rise Hold	t_{CS1}		40			ns
\overline{CS} Pulse Width High	t_{CSW}		100			ns

Note 1: Accuracy is specified from code 2 to code 1023.

Note 2: Accuracy is better than 1LSB for $V_{OUT_{-}}$ greater than 6mV and less than $V_{DD} - 50mV$. Guaranteed by PSRR test at the end points.

Note 3: Digital inputs are set to either V_{DD} or DGND, code = 0000 hex, $R_L = \infty$.

Note 4: SCLK minimum clock period includes rise and fall times.

Low-Power, Dual, 10-Bit Voltage-Output DACs with Serial Interface

ELECTRICAL CHARACTERISTICS—MAX5159

($V_{DD} = +2.7V$ to $+3.6V$, $V_{REFA} = V_{REFB} = 1.25V$, $R_L = 10k\Omega$, $C_L = 100pF$, $T_A = T_{MIN}$ to T_{MAX} , unless otherwise noted. Typical values are at $T_A = +25^\circ C$ (OS_ pins tied to AGND for a gain of $+2V/V$.)

PARAMETER	SYMBOL	CONDITIONS	MIN	TYP	MAX	UNITS
STATIC PERFORMANCE						
Resolution			10			Bits
Integral Nonlinearity	INL	(Note 5)			± 1	LSB
Differential Nonlinearity	DNL	Guaranteed monotonic			± 1	LSB
Offset Error	V_{OS}	Code = 3			± 6	mV
Offset Tempco	TCV_{OS}	Normalized to 1.25V		6.5		ppm/ $^\circ C$
Gain Error				-0.1	± 1	LSB
Gain-Error Tempco		Normalized to 1.25V		6.5		ppm/ $^\circ C$
V_{DD} Power-Supply Rejection Ratio	PSRR	$2.7V \leq V_{DD} \leq 3.6V$		40	320	$\mu V/V$
REFERENCE INPUT (VREF)						
Reference Input Range	REF		0		$V_{DD} - 1.4$	V
Reference Input Resistance	R_{REF}	Minimum with code 1558 hex	18	25		$k\Omega$
MULTIPLYING-MODE PERFORMANCE						
Reference 3dB Bandwidth		Input code = 1FF8 hex, $V_{REF_} = 0.67V_{p-p}$ at $0.75V_{DC}$		300		kHz
Reference Feedthrough		Input code = 0000 hex, $V_{REF_} = (V_{DD} - 1.4)V_{p-p}$ at 1kHz		-82		dB
Signal-to-Noise plus Distortion Ratio	SINAD	Input code = 1FF8 hex, $V_{REF_} = 1V_{p-p}$ at $1V_{DC}$, $f = 15kHz$		73		dB
DIGITAL INPUTS						
Input High Voltage	V_{IH}	\overline{CL} , \overline{PDL} , \overline{CS} , DIN, SCLK	2.2			V
Input Low Voltage	V_{IL}	\overline{CL} , \overline{PDL} , \overline{CS} , DIN, SCLK			0.8	V
Input Hysteresis	V_{HYS}			200		mV
Input Leakage Current	I_{IN}	$V_{IN} = 0V$ to V_{DD}		0	± 1	μA
Input Capacitance	C_{IN}			8		pF
DIGITAL OUTPUTS						
Output High Voltage	V_{OH}	$I_{SOURCE} = 2mA$	$V_{DD} - 0.5$			V
Output Low Voltage	V_{OL}	$I_{SINK} = 2mA$		0.13	0.4	V
DYNAMIC PERFORMANCE (DOUT, UPO)						
Voltage Output Slew Rate	SR			0.75		V/ μs
Output Settling Time		To $1/2LSB$ of full-scale, $V_{STEP} = 2.5V$		8		μs
Output Voltage Swing		Rail-to-rail (Note 6)		0 to V_{DD}		V
OSA or OSB Input Resistance	$R_{OS_}$		24	34		$k\Omega$
Time Required for Valid Operation after Shutdown				25		μs
Digital Feedthrough		$\overline{CS} = V_{DD}$, $f_{DIN} = 100kHz$, $V_{SCLK} = 3V_{p-p}$		5		nV-s
Digital Crosstalk				5		nV-s

Low-Power, Dual, 10-Bit, Voltage-Output DACs with Serial Interface

MAX5158/MAX5159

ELECTRICAL CHARACTERISTICS—MAX5159 (continued)

($V_{DD} = +2.7V$ to $+3.6V$, $V_{REFA} = V_{REFB} = 1.25V$, $R_L = 10k\Omega$, $C_L = 100pF$, $T_A = T_{MIN}$ to T_{MAX} , unless otherwise noted. Typical values are at $T_A = +25^\circ C$ (OS_ pins tied to AGND for a gain of $+2V/V$.)

PARAMETER	SYMBOL	CONDITIONS	MIN	TYP	MAX	UNITS
POWER SUPPLIES						
Positive Supply Voltage	V_{DD}		2.7		3.6	V
Power-Supply Current	I_{DD}	(Note 7)		0.5	0.6	mA
Power-Supply Current in Shutdown	$I_{DD}(SHDN)$	(Note 7)		1	8	μA
Reference Current in Shutdown					± 1	μA
TIMING CHARACTERISTICS						
SCLK Clock Period	t_{CP}	(Note 4)	100			ns
SCLK Pulse Width High	t_{CH}		40			ns
SCLK Pulse Width Low	t_{CL}		40			ns
\overline{CS} Fall to SCLK Rise Setup Time	t_{CSS}		40			ns
SCLK Rise to \overline{CS} Rise Hold Time	t_{CSH}		0			ns
SDI Setup Time	t_{DS}		50			ns
SDI Hold Time	t_{DH}		0			ns
SCLK Rise to DOUT Valid Propagation Delay	t_{DO1}	$C_{LOAD} = 200pF$			120	ns
SCLK Fall to DOUT Valid Propagation Delay	t_{DO2}	$C_{LOAD} = 200pF$			120	ns
SCLK Rise to \overline{CS} Fall Delay	t_{CS0}		10			ns
\overline{CS} Rise to SCLK Rise Hold	t_{CS1}		40			ns
\overline{CS} Pulse Width High	t_{CSW}		100			ns

Note 5: Accuracy is specified from code 3 to code 1023.

Note 6: Accuracy is better than 1LSB for V_{OUT} greater than 6mV and less than $V_{DD} - 80mV$. Guaranteed by PSRR test at the end points.

Note 7: Digital inputs are set to either V_{DD} or DGND, code = 0000 hex, $R_L = \infty$.

Low-Power, Dual, 10-Bit Voltage-Output DACs with Serial Interface

Typical Operating Characteristics

($V_{DD} = +5V$, $R_L = 10k\Omega$, $C_L = 100pF$, OS_ pins tied to AGND, $T_A = +25^\circ C$, unless otherwise noted.)

MAX5158

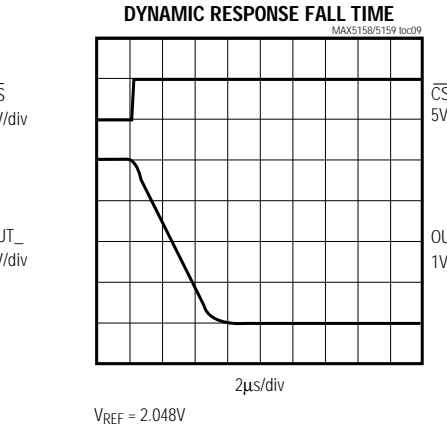
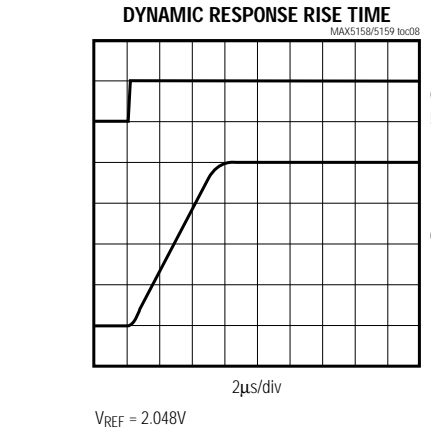
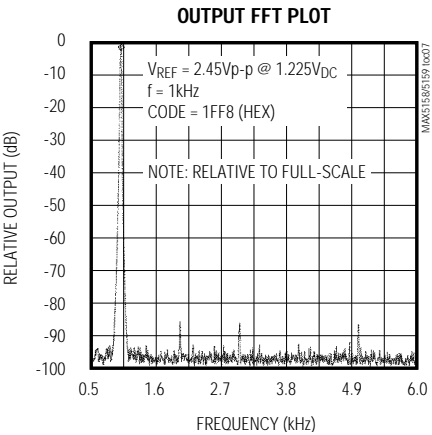
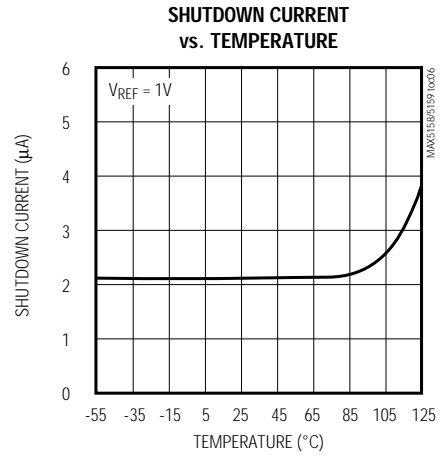
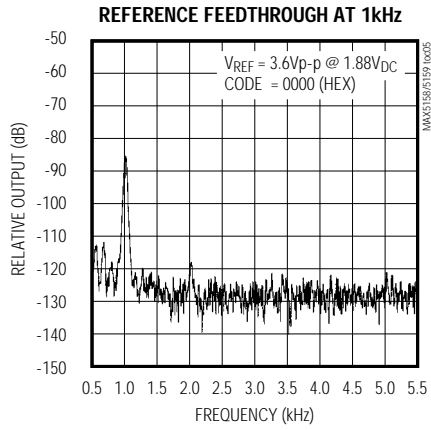
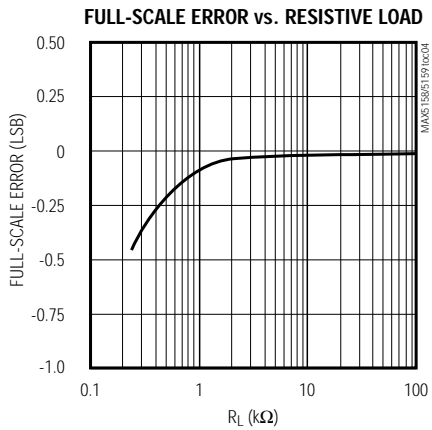
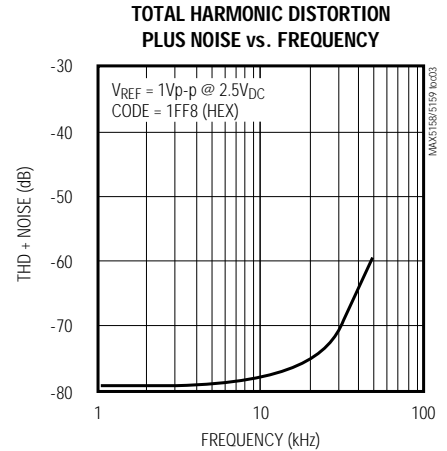
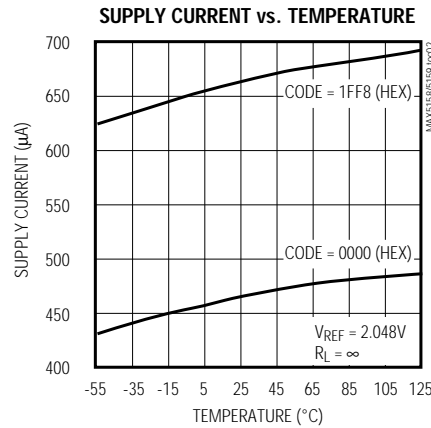
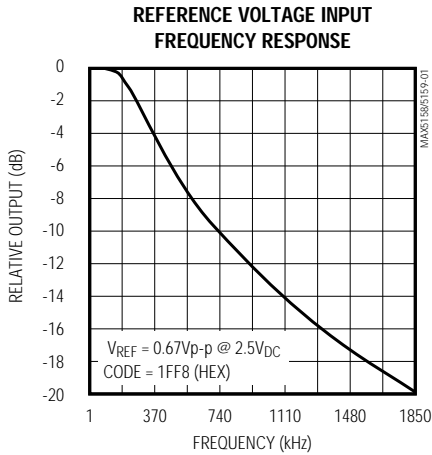

Low-Power, Dual, 10-Bit, Voltage-Output DACs with Serial Interface

MAX5158/MAX5159

Typical Operating Characteristics (continued)

($V_{DD} = +3V$, $R_L = 10k\Omega$, $C_L = 100pF$, OS_ pins tied to AGND, $T_A = +25^\circ C$, unless otherwise noted.)

MAX5159

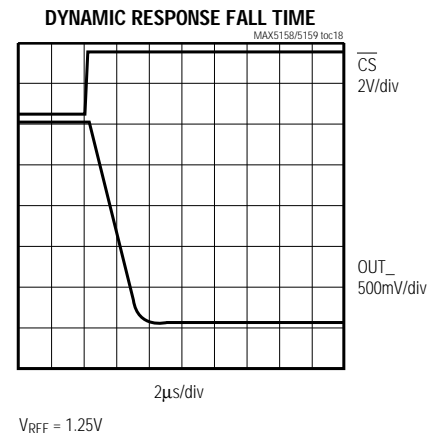
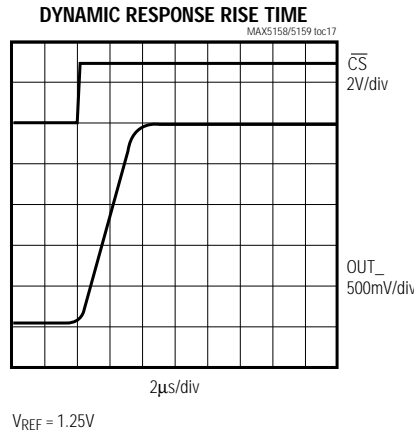
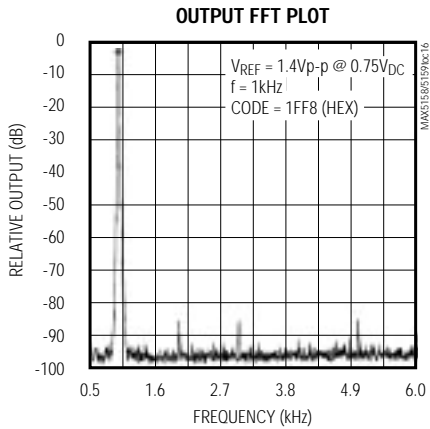
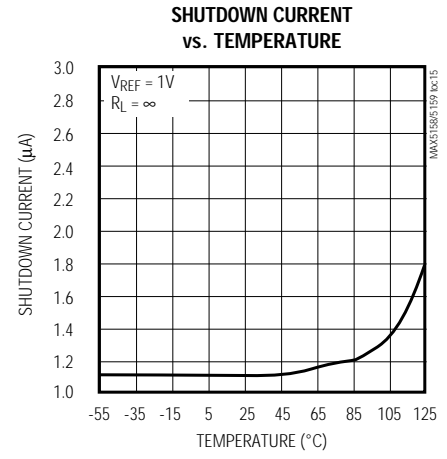
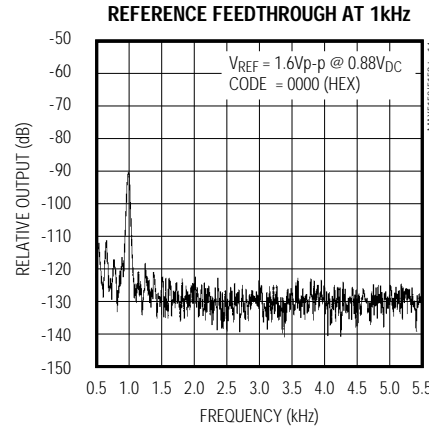
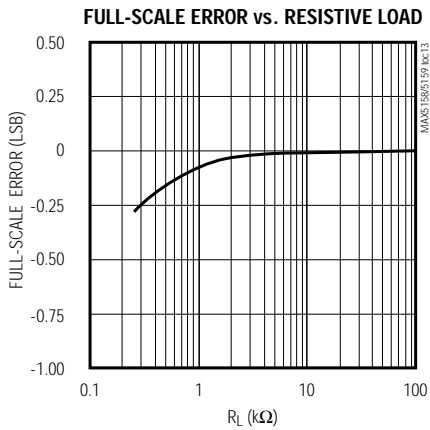
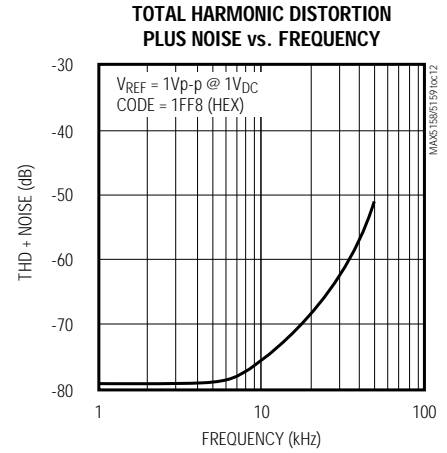
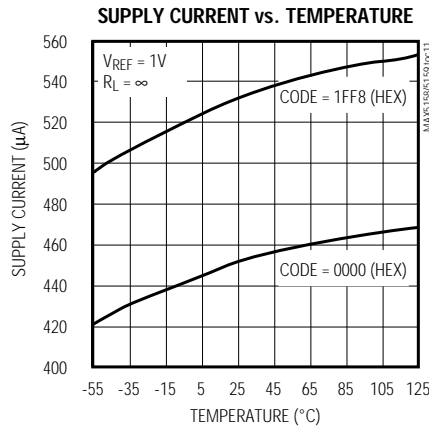
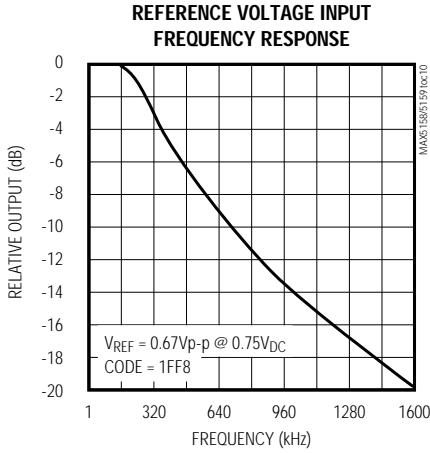

Low-Power, Dual, 10-Bit Voltage-Output DACs with Serial Interface

Typical Operating Characteristics (continued)

($V_{DD} = +5V$ (MAX5158), $V_{DD} = +3V$ (MAX5159), $R_L = 10k\Omega$, $C_L = 100pF$, OS_{-} pins tied to AGND, unless otherwise noted.)

MAX5158/MAX5159

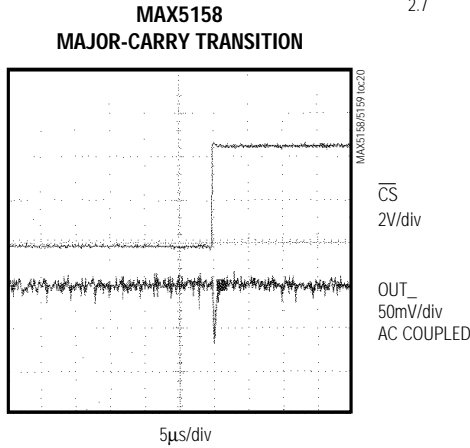
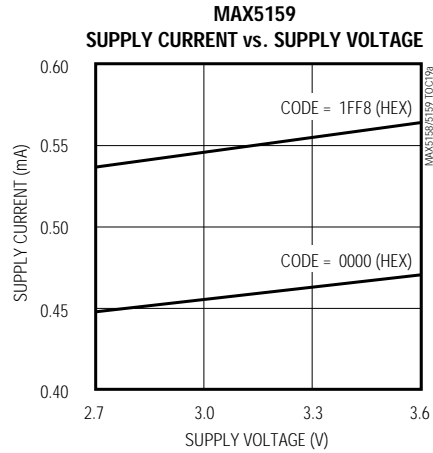
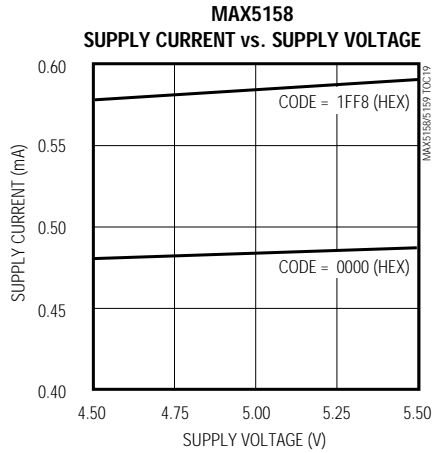

TRANSITION FROM 1000 (HEX) TO 0FF8 (HEX)

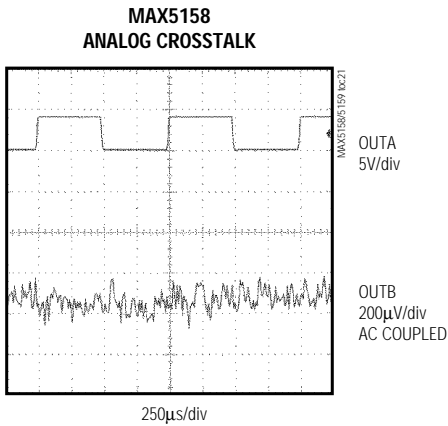

$V_{REF} = 2.048V$, GAIN = +2V/V, CODE = 1FF8 HEX

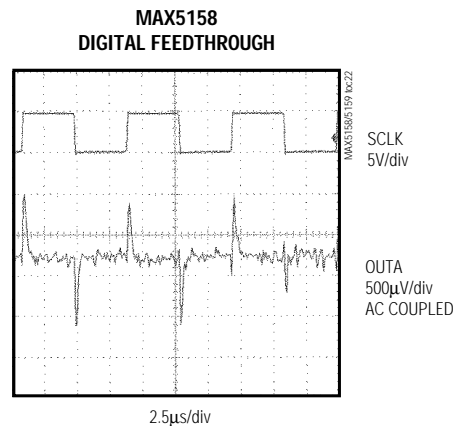

Low-Power, Dual, 10-Bit, Voltage-Output DACs with Serial Interface

MAX5158/MAX5159

Pin Description

PIN	NAME	FUNCTION
1	AGND	Analog Ground
2	OUTA	DAC A Output Voltage
3	OSA	DAC A Offset Adjustment
4	REFA	Reference for DAC A
5	$\overline{\text{CL}}$	Active-Low Clear Input. Resets all registers to zero. DAC outputs go to 0V.
6	$\overline{\text{CS}}$	Chip-Select Input
7	DIN	Serial-Data Input
8	SCLK	Serial Clock Input
9	DGND	Digital Ground
10	DOUT	Serial-Data Output
11	UPO	User-Programmable Output
12	$\overline{\text{PDL}}$	Power-Down Lockout. The device cannot be powered down when $\overline{\text{PDL}}$ is low.
13	REFB	Reference for DAC B
14	OSB	DAC B Offset Adjustment
15	OUTB	DAC B Output Voltage
16	V _{DD}	Positive Power Supply

Detailed Description

The MAX5158/MAX5159 dual, 10-bit, voltage-output DACs are easily configured with a 3-wire serial interface. These devices include a 16-bit data-in/data-out shift register, and each DAC has a double-buffered input composed of an input register and a DAC register (see *Functional Diagram*). In addition, trimmed internal resistors produce an internal gain of +2V/V that maximizes output voltage swing. The amplifier's offset-adjust pin allows for a DC shift in the DAC's output.

Both DACs use an inverted R-2R ladder network that produces a weighted voltage proportional to the input voltage value. Each DAC has its own reference input to facilitate independent full-scale values. Figure 1 depicts a simplified circuit diagram of one of the two DACs.

Reference Inputs

The reference inputs accept both AC and DC values with a voltage range extending from 0V to (V_{DD} - 1.4V). Determine the output voltage using the following equation (OS₋ = AGND):

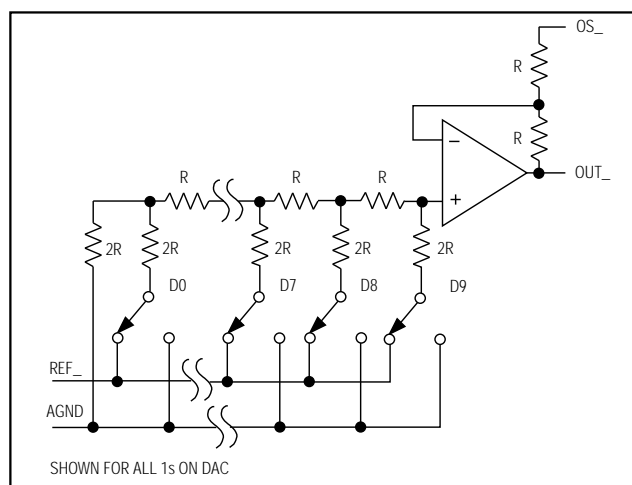

Figure 1. Simplified DAC Circuit Diagram

$$V_{\text{OUT}} = (V_{\text{REF}} \times \text{NB} / 1024) \times 2$$

where NB is the numeric value of the DAC's binary input code (0 to 1023) and V_{REF} is the reference voltage.

The reference input impedance ranges from 18kΩ (1558 hex) to several giga ohms (with an input code of 0000 hex). The reference input capacitance is code dependent and typically ranges from 15pF with an input code of all zeros to 50pF with a full-scale input code.

Output Amplifier

The output amplifiers on the MAX5158/MAX5159 have internal resistors that provide for a gain of +2V/V when OS₋ is connected to AGND. These resistors are trimmed to minimize gain error. The output amplifiers have a typical slew rate of 0.75V/μs and settle to 1/2LSB within 8μs, with a load of 10kΩ in parallel with 100pF. Loads less than 2kΩ degrade performance.

The OS₋ pin can be used to produce an adjustable offset voltage at the output. For instance, to achieve a 1V offset, apply -1V to the OS₋ pin to produce an output range from 1V to (1V + V_{REF} × 2). Note that the DAC's output range is still limited by the maximum output voltage specification.

Power-Down Mode

The MAX5158/MAX5159 feature a software-programmable shutdown mode that reduces the typical supply current to 2μA. The two DACs can be shutdown independently, or simultaneously using the appropriate programming command. Enter shutdown mode by writing the appropriate input-control word (Table 1). In shutdown mode, the reference inputs and amplifier outputs become high impedance, and the serial interface

Low-Power, Dual, 10-Bit Voltage-Output DACs with Serial Interface

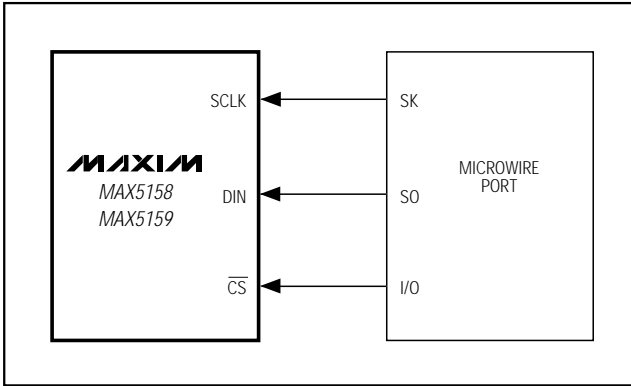

Figure 2. Connections for Microwire

remains active. Data in the input registers is saved, allowing the MAX5158/MAX5159 to recall the output state prior to entering shutdown when returning to normal mode. Exit shutdown by recalling the previous condition or by updating the DAC with new information. When returning to normal operation (exiting shutdown), wait 20µs for output stabilization.

Serial Interface

The MAX5158/MAX5159 3-wire serial interface is compatible with both Microwire (Figure 2) and SPI/QSPI (Figure 3) serial-interface standards. The 16-bit serial input word consists of an address bit, two control bits, 10 bits of data (MSB to LSB), and 3 sub-bits as shown in Figure 4. The address and control bits determine the MAX5158/MAX5159's response, as outlined in Table 1.

Table 1. Serial-Interface Programming Command

16-BIT SERIAL WORD					FUNCTION
A0	C1	C0	D9.....D0 (MSB) (LSB)	S2-S0	
0	0	1	10-bit DAC data	0 0 0	Load input register A; DAC registers are unchanged.
1	0	1	10-bit DAC data	0 0 0	Load input register B; DAC registers are unchanged.
0	1	0	10-bit DAC data	0 0 0	Load input register A; all DAC registers are updated.
1	1	0	10-bit DAC data	0 0 0	Load input register B; all DAC registers are updated.
0	1	1	10-bit DAC data	0 0 0	Load all DAC registers from the shift register (start up both DACs with new data.).
1	0	0	xxxxxxxx	0 0 0	Update both DAC registers from their respective input registers (start up both DACs with data previously stored in the input registers).
1	1	1	xxxxxxxx	0 0 0	Shut down both DACs (provided $\overline{PDL} = 1$).
0	0	0	0 0 1 x xxxxxx	0 0 0	Update DAC register A from input register A (start up DAC A with data previously stored in input register A).
0	0	0	1 0 1 x xxxxxx	0 0 0	Update DAC register B from input register B (start up DAC B with data previously stored in input register B).
0	0	0	1 1 0 x xxxxxx	0 0 0	Shut down DAC A (provided $\overline{PDL} = 1$).
0	0	0	1 1 1 x xxxxxx	0 0 0	Shut down DAC B (provided $\overline{PDL} = 1$).
0	0	0	0 1 0 x xxxxxx	0 0 0	UPO goes low (default).
0	0	0	0 1 1 x xxxxxx	0 0 0	UPO goes high.
0	0	0	1 0 0 1 xxxxxx	0 0 0	Mode 1, DOOUT clocked out on SCLK's rising edge.
0	0	0	1 0 0 0 xxxxxx	0 0 0	Mode 0, DOOUT clocked out on SCLK's falling edge (default).
0	0	0	0 0 0 x xxxxxx	0 0 0	No operation (NOP).

x = Don't care

Note: When A0, C1, and C0 = 0, then D9, D8, D7, and D6 become control bits. S2-S0 are sub bits, always zero.

Low-Power, Dual, 10-Bit, Voltage-Output DACs with Serial Interface

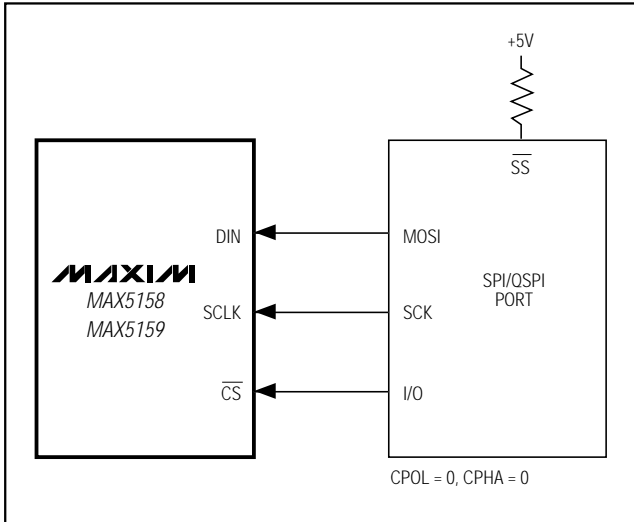

Figure 3. Connections for SPI/QSPI

The MAX5158/MAX5159's digital inputs are double buffered, which allows any of the following: loading the input register(s) without updating the DAC register(s), updating the DAC register(s) from the input register(s), or updating the input and DAC registers concurrently. The address and control bits allow the DACs to act independently.

Send the 16-bit data as one 16-bit word (QSPI) or two 8-bit packets (SPI, Microwire), with \overline{CS} low during this period. The address and control bits determine which register will be updated and the state of the registers when exiting shutdown. The 3-bit address/control determines the following:

- registers to be updated
- clock edge on which data is to be clocked out via the serial-data output (DOUT)
- state of the user-programmable logic output
- configuration of the device after shutdown.

The general timing diagram of Figure 5 illustrates how data is acquired. Driving \overline{CS} low enables the device to receive data. Otherwise, the interface control circuitry is disabled. With \overline{CS} low, data at DIN is clocked into the register on the rising edge of SCLK. As \overline{CS} goes high, data is latched into the input and/or DAC registers, depending on the address and control bits. The maximum clock frequency guaranteed for proper operation is 10MHz. Figure 6 depicts a more detailed timing diagram of the serial interface.

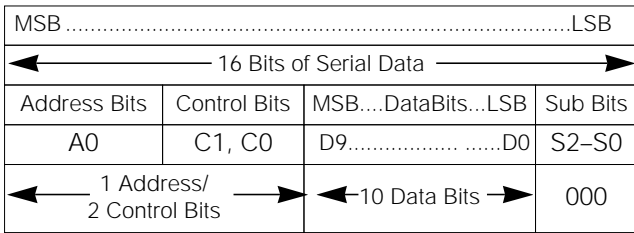

Figure 4. Serial-Data Format

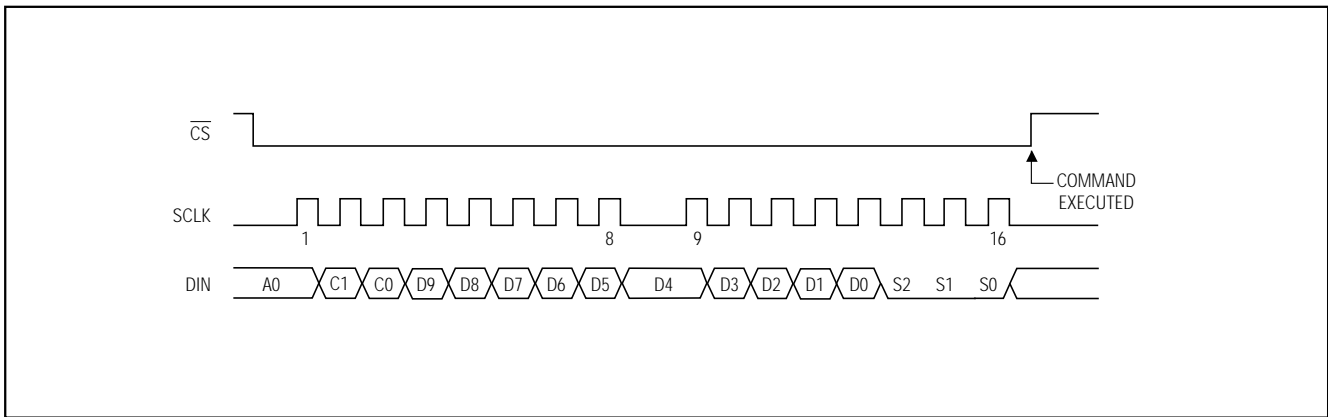

Figure 5. Serial-Interface Timing Diagram

Low-Power, Dual, 10-Bit Voltage-Output DACs with Serial Interface

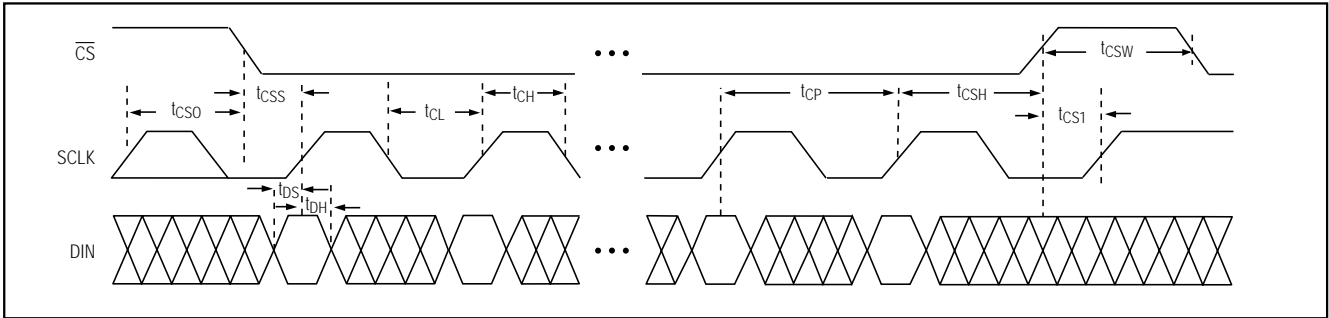

Figure 6. Detailed Serial-Interface Timing Diagram

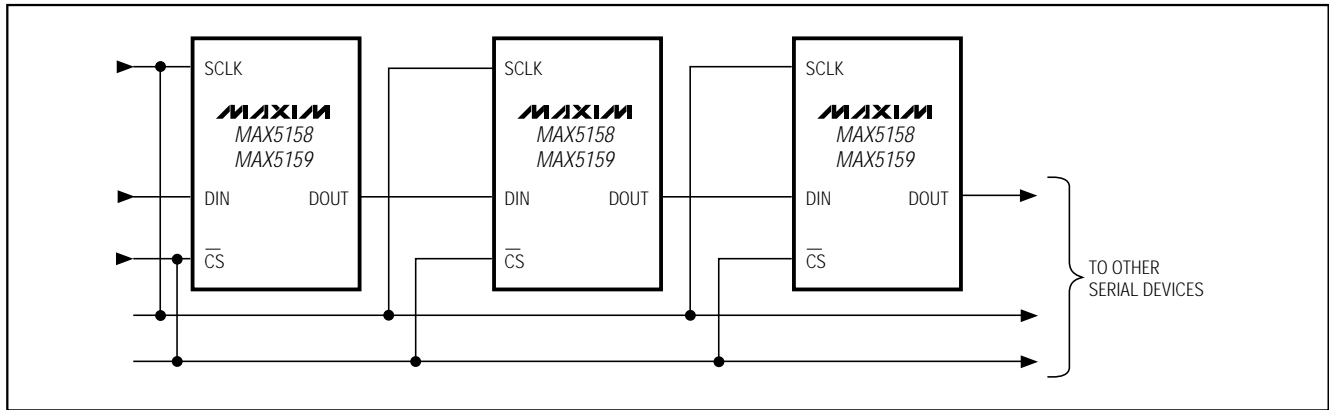

Figure 7. Daisy Chaining MAX5158/MAX5159s

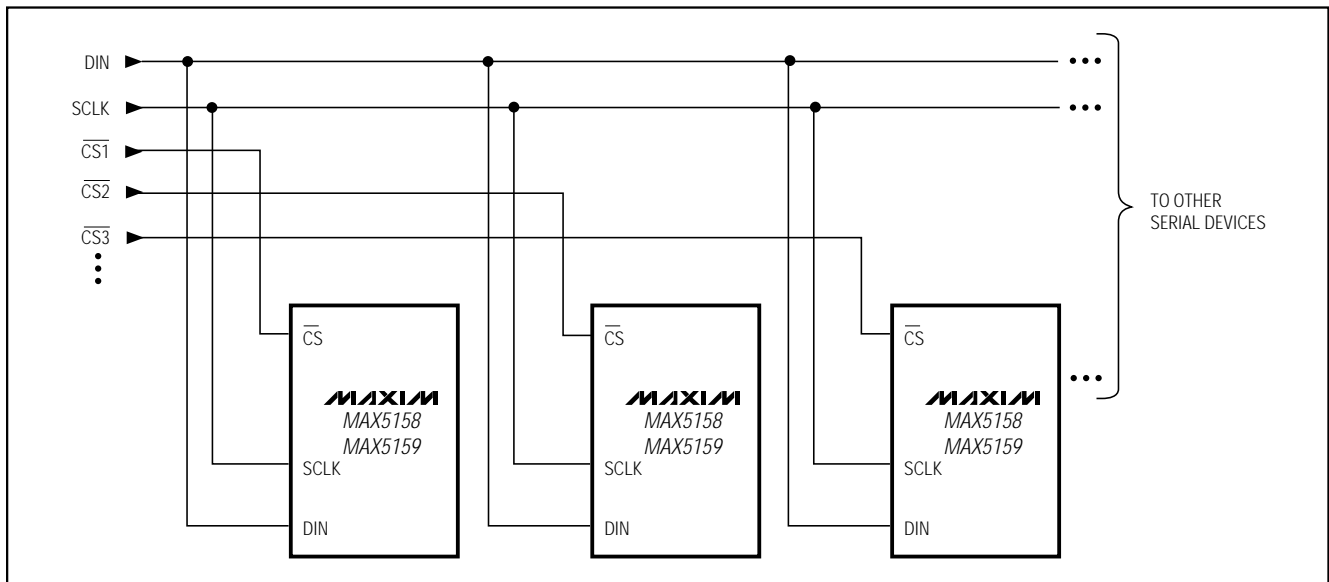

Figure 8. Multiple MAX5158/MAX5159s Sharing a Common DIN Line

Low-Power, Dual, 10-Bit, Voltage-Output DACs with Serial Interface

Table 2. Unipolar Code Table (Gain = +2)

DAC CONTENTS		ANALOG OUTPUT
MSB	LSB	
11	1111 1111 (000)	$+V_{REF} \left(\frac{1023}{1024} \right) \times 2$
10	0000 0001 (000)	$+V_{REF} \left(\frac{513}{1024} \right) \times 2$
10	0000 0000 (000)	$+V_{REF} \left(\frac{512}{1024} \right) \times 2 = V_{REF}$
01	1111 1111 (000)	$+V_{REF} \left(\frac{511}{1024} \right) \times 2$
00	0000 0001 (000)	$+V_{REF} \left(\frac{1}{1024} \right)$
00	0000 0000 (000)	0V

Note: () are for the sub bits.

Serial-Data Output

The serial-data output, DOUT, is the internal shift register's output. DOUT allows for daisy chaining of devices and data readback. The MAX5158/MAX5159 can be programmed to shift data out of DOUT on SCLK's falling edge (Mode 0) or on the rising edge (Mode 1). Mode 0 provides a lag of 16 clock cycles, which maintains compatibility with SPI/OSPI and Microwire interfaces. In Mode 1, the output data lags 15.5 clock cycles. On power-up, the device defaults to Mode 0.

User-Programmable Logic Output (UPO)

UPO allows an external device to be controlled through the serial interface (Table 1), thereby reducing the number of microcontroller I/O pins required. On power-up, UPO is low.

Power-Down Lockout Input (PDL)

The power-down lockout pin (\overline{PDL}) disables software shutdown when low. When in shutdown, transitioning \overline{PDL} from high to low wakes up the part with the output set to the state prior to shutdown. \overline{PDL} can also be used to asynchronously wake up the device.

Daisy Chaining Devices

Any number of MAX5158/MAX5159s can be daisy chained by connecting the DOUT pin of one device to the DIN pin of the following device in the chain (Figure 7).

Since the MAX5158/MAX5159's DOUT pin has an internal active pull-up, the DOUT sink/source capability determines the time required to discharge/charge a capacitive

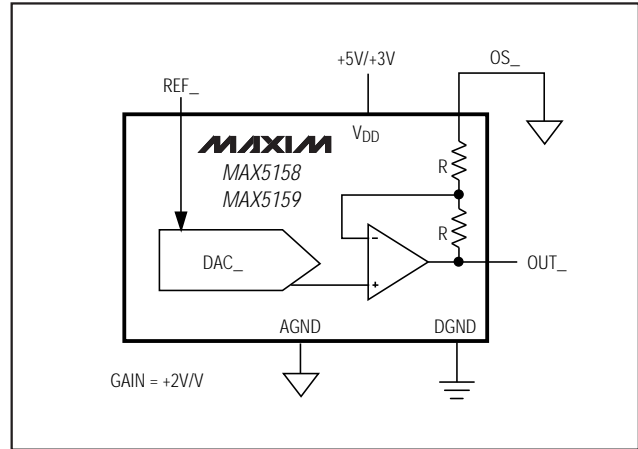

Figure 9. Unipolar Output Circuit (Rail-to-Rail)

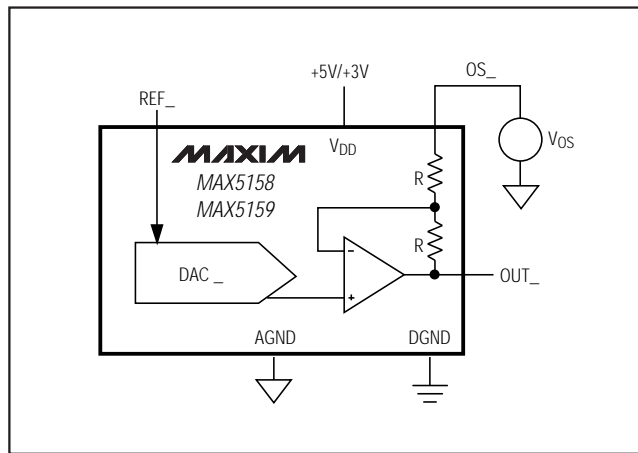

Figure 10. Setting OS_ for Output Offset

load. Refer to the digital output V_{OH} and V_{OL} specifications in the *Electrical Characteristics*.

Figure 8 shows an alternate method of connecting several MAX5158/MAX5159s. In this configuration, the data bus is common to all devices; data is not shifted through a daisy chain. More I/O lines are required in this configuration because a dedicated chip-select input (\overline{CS}) is required for each IC.

Applications Information

Unipolar Output

Figure 9 shows the MAX5158/MAX5159 configured for unipolar, rail-to-rail operation with a gain of +2V/V. The MAX5158 can produce a 0V to 4.096V output with a 2.048V reference (Figure 9), while the MAX5159 can

Low-Power, Dual, 10-Bit Voltage-Output DACs with Serial Interface

Table 3. Bipolar Code Table

DAC CONTENTS MSB	LSB	ANALOG OUTPUT
11 1111 1111 (000)		$+V_{REF} \left(\frac{511}{512} \right)$
10 0000 0001 (000)		$+V_{REF} \left(\frac{1}{512} \right)$
10 0000 0000 (000)		0V
01 1111 1111 (000)		$-V_{REF} \left(\frac{1}{512} \right)$
00 0000 0001 (000)		$-V_{REF} \left(\frac{511}{512} \right)$
00 0000 0000 (000)		$-V_{REF} \left(\frac{512}{512} \right) = -V_{REF}$

Note: () are for the sub bits.

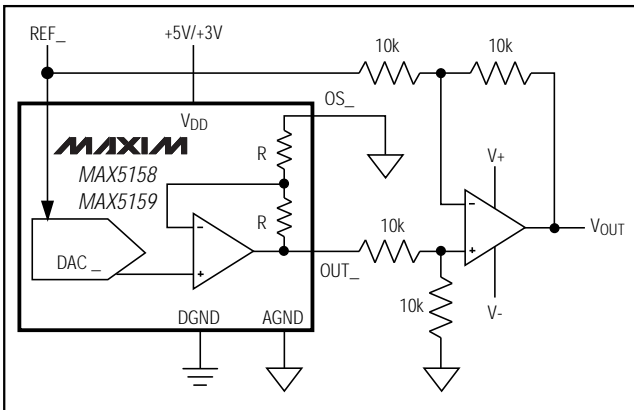

Figure 11. Bipolar Output Circuit

produce a range of 0V to 2.5V with a 1.25V reference. Table 2 lists the unipolar output codes. An offset to the output can be achieved by connecting a voltage to OS₋, as shown in Figure 10. By applying V_{OS₋} = -1V, the output values will range between 1V and (1V + V_{REF} × 2).

Bipolar Output

The MAX5158/MAX5159 can be configured for a bipolar output, as shown in Figure 11. The output voltage is given by the equation (OS₋ = AGND):

$$V_{OUT} = V_{REF} \left[\left(\frac{2 \times NB}{1024} \right) - 1 \right]$$

where NB represents the numeric value of the DAC's binary input code. Table 3 shows digital codes and the corresponding output voltage for Figure 11's circuit.

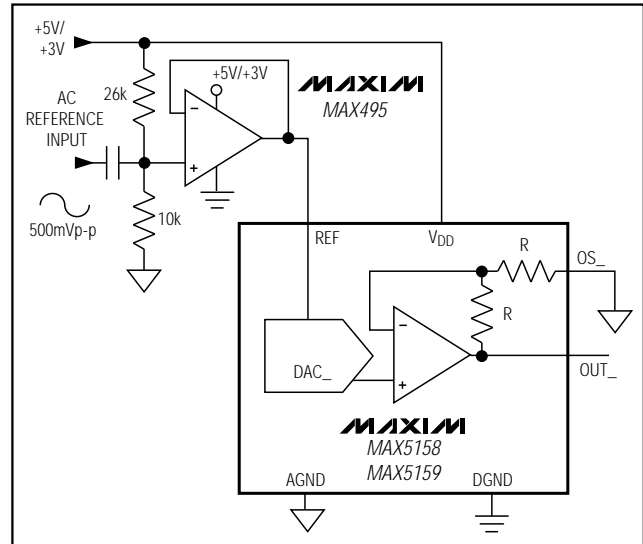

Figure 12. AC Reference Input Circuit

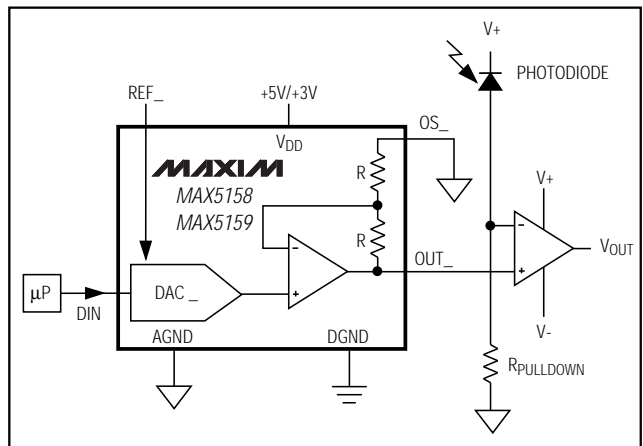

Figure 13. Digital Calibration

Using an AC Reference

In applications where the reference has an AC signal component, the MAX5158/MAX5159 have multiplying capabilities within the reference input voltage range specifications. Figure 12 shows a technique for applying a sinusoidal input to REF₋, where the AC signal is offset before being applied to the reference input.

Harmonic Distortion and Noise

The total harmonic distortion plus noise (THD+N) is typically less than -78dB at full scale with a 1Vp-p input swing at 5kHz. The typical -3dB frequency is 300kHz for both devices, as shown in the *Typical Operating Characteristics*.

Low-Power, Dual, 10-Bit, Voltage-Output DACs with Serial Interface

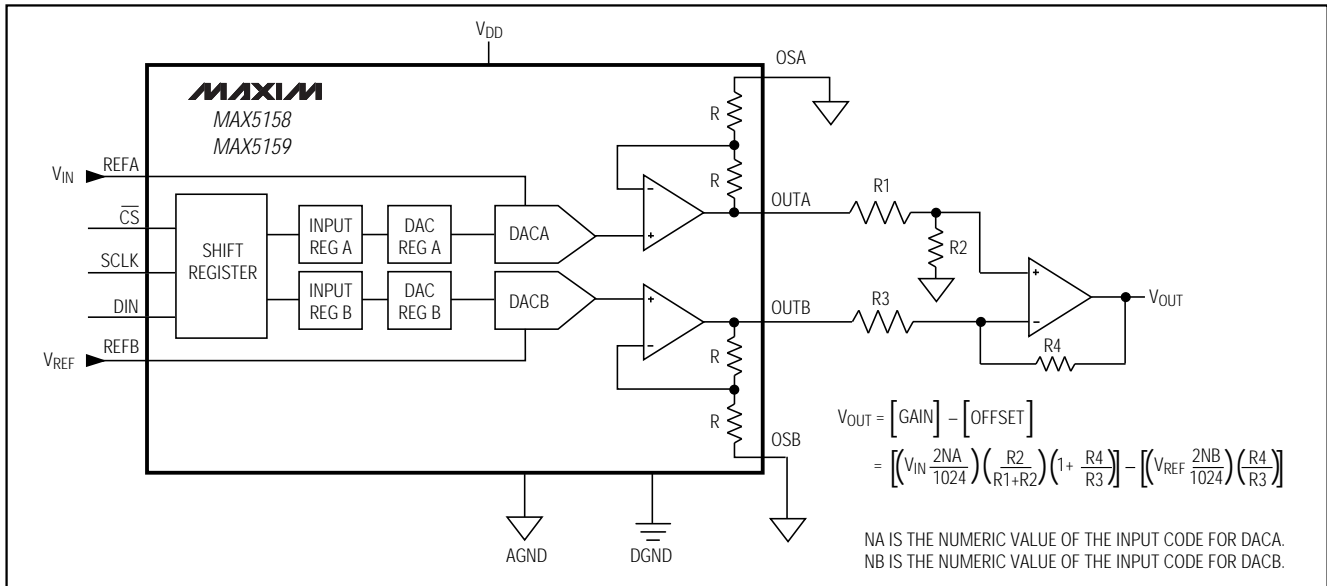

Figure 14. Digital Control of Gain and Offset

Digital Calibration and Threshold Selection

Figure 13 shows the MAX5158/MAX5159 in a digital calibration application. With a bright light value applied to the photodiode (on), the DAC is digitally ramped until it trips the comparator. The microprocessor (μP) stores this "high" calibration value. Repeat the process with a dim light (off) to obtain the dark current calibration. The μP then programs the DAC to set an output voltage at the midpoint of the two calibrated values. Applications include tachometers, motion sensing, automatic readers, and liquid clarity analysis.

Digital Control of Gain and Offset

The two DACs can be used to control the offset and gain for curve-fitting nonlinear functions, such as transducer linearization or analog compression/expansion applications. The input signal is used as the reference for the gain-adjust DAC, whose output is summed with the output from the offset-adjust DAC. The relative weight of each DAC output is adjusted by R1, R2, R3, and R4 (Figure 14).

Power-Supply Considerations

On power-up, the input and DAC registers clear (set to zero code). For rated performance, $V_{REF_}$ should be at least 1.4V below V_{DD} . Bypass the power supply with a 4.7 μF capacitor in parallel with a 0.1 μF capacitor to AGND. Minimize lead lengths to reduce lead inductance.

Grounding and Layout Considerations

Digital and AC transient signals on AGND can create noise at the output. Connect AGND to the highest quality ground available. Use proper grounding techniques, such as a multilayer board with a low-inductance ground plane. Carefully lay out the traces between channels to reduce AC cross-coupling and crosstalk. Wire-wrapped boards and sockets are not recommended. If noise becomes an issue, shielding may be required.

Low-Power, Dual, 13-Bit Voltage-Output DACs with Serial Interface

Pin Configuration

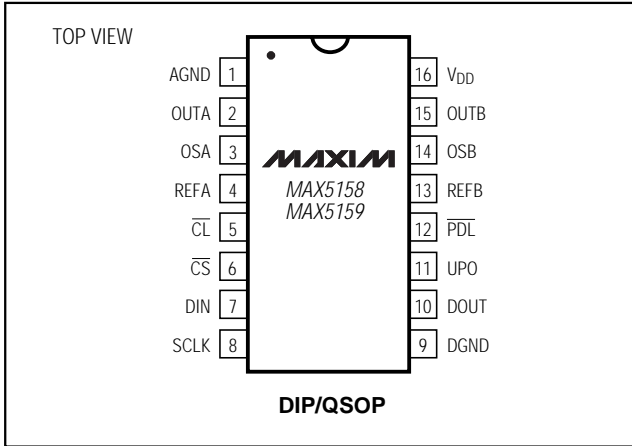

Ordering Information (continued)

PART	TEMP. RANGE	PIN-PACKAGE
MAX5159CPE	0°C to +70°C	16 Plastic DIP
MAX5159CEE	0°C to +70°C	16 QSOP
MAX5159EPE	-40°C to +85°C	16 Plastic DIP
MAX5159EEE	-40°C to +85°C	16 QSOP
MAX5159MJE	-55°C to +125°C	16 CERDIP*

*Contact factory for availability.

Chip Information

TRANSISTOR COUNT: 3053

SUBSTRATE CONNECTED TO AGND

Package Information

DIM	INCHES		MILLIMETERS	
	MIN	MAX	MIN	MAX
A	.061	.068	1.55	1.73
A1	.004	.0098	0.127	0.25
A2	.055	.061	1.40	1.55
B	.008	.012	0.20	0.31
C	.0075	.0098	0.19	0.25
D	SEE VARIATIONS			
E	.150	.157	3.81	3.99
e	.025 BSC		0.635 BSC	
H	.230	.244	5.84	6.20
h	.010	.016	0.25	0.41
L	.016	.035	0.41	0.89
N	SEE VARIATIONS			
S	SEE VARIATIONS			
?	0°	8°	0°	8°

VARIATIONS:

DIM	INCHES		MILLIMETERS		N
	MIN.	MAX.	MIN.	MAX.	
D	.189	.196	4.80	4.98	16
S	.0020	.0070	0.05	0.18	
D	.337	.344	8.56	8.74	20
S	.0500	.0550	1.27	1.40	
D	.337	.344	8.56	8.74	24
S	.0250	.0300	0.64	0.76	
D	.386	.393	9.80	9.98	28
S	.0250	.0300	0.64	0.76	

NOTES:

- D & E DO NOT INCLUDE MOLD FLASH OR PROTRUSIONS
- MOLD FLASH OR PROTRUSIONS NOT TO EXCEED .006"
- CONTROLLING DIMENSIONS: INCHES

MAXIM
 PROPRIETARY INFORMATION
 TITLE: PACKAGE OUTLINE, QSOP, .150 INCH, .025" LEAD PITCH
 APPROVAL: [] REG. CONTROL: [] REV: []
 21-0055 A 1/1

Maxim cannot assume responsibility for use of any circuitry other than circuitry entirely embodied in a Maxim product. No circuit patent licenses are implied. Maxim reserves the right to change the circuitry and specifications without notice at any time.

16 Maxim Integrated Products, 120 San Gabriel Drive, Sunnyvale, CA 94086 408-737-7600

Looking for pricing, stock, or lifecycle information?

Click below to explore more details on WIN SOURCE:

 [View MAX5159CEE](#) on WIN SOURCE

 [Maxim Integrated](#) Information

Optimize Your Supply Chain with WIN SOURCE Solutions

-  Global Sourcing Solution
-  Obsolete Management
-  Cost Control Management
-  Shortage Management
-  Alternative Solution
-  Excess Inventory Management