



**THE DATASHEET OF
MP3336GC-P**



DESCRIPTION

The MP3336 is a compact, dual-channel, high-power, flash, LED driver that can drive up to 2A in flash mode for each LED. It is usually applied for camera phones to improve image and video quality in low-light environments. The MP3336 operates with a selectable 1/2/3/4MHz switching frequency and uses a synchronous, current-mode PWM boost converter to regulate the LED current with two high-current sources. The MP3336 provides high efficiency and an optimized solution for smaller PCB spaces.

The MP3336 features a standard I²C interface, dual LED channels, rich protection modes, and high power density and performances. The MP3336 can also support flash, assist, torch, indicator, and 5V DC modes.

The cathodes of the dual-flash LED are referenced to GND, which is better for improving thermal performance in layout. The MP3336 is available in a WLCSP-20 (1.6mmx2.0mm) package.

FEATURES

- 2.7V~5.5V Input Voltage
- 1/2/3/4MHz Selectable Max Switching Frequency
- Switching Frequency Fold-back Function
- 400kHz I²C Compatible Interface
- Standby/Flash/Assist/Torch/Indicator/5V DC Modes

Flash Mode

- Up to 2A/Ch Programmable Current with $\pm 7\%$ Accuracy for Each LED, 7.84mA/Step

Assist/Torch Mode

- Up to 319mA/Ch Programmable Current with $\pm 7\%$ Accuracy for Each LED, 1.25mA/Step

Indicator Mode

- Works in 31.5kHz PWM Dimming Mode with 2/16, 3/16, 4/16, 5/16 Duty Cycle
- Used for Blinking and 128/256/512ms Selectable Blinking Time

5V DC Mode

- Output Constant 5V DC Voltage
- 1A to 4.2A Programmable Input DC Current Limit Protection
- External Torch/Strobe/TX Pin
- LED Forward-Voltage Balance to Improve Efficiency
- VIN to VOUT Disconnection Function
- Low-Battery Voltage Protection
- LED Short/Open Protection
- VOUT-GND Short Protection
- Over-Voltage Protection (OVP)
- Over-Temperature Protection (OTP)
- Input Under-Voltage Lockout (UVLO) Protection
- Available in a WLCSP-20 (1.6mmx2.0mm) Package

APPLICATIONS

- Smartphone Flash LED Application
- Cameras for Tablets
- Digital Still Camera

All MPS parts are lead-free, halogen-free, and adhere to the RoHS directive. For MPS green status, please visit the MPS website under Quality Assurance. "MPS" and "The Future of Analog IC Technology" are registered trademarks of Monolithic Power Systems, Inc.

TYPICAL APPLICATION

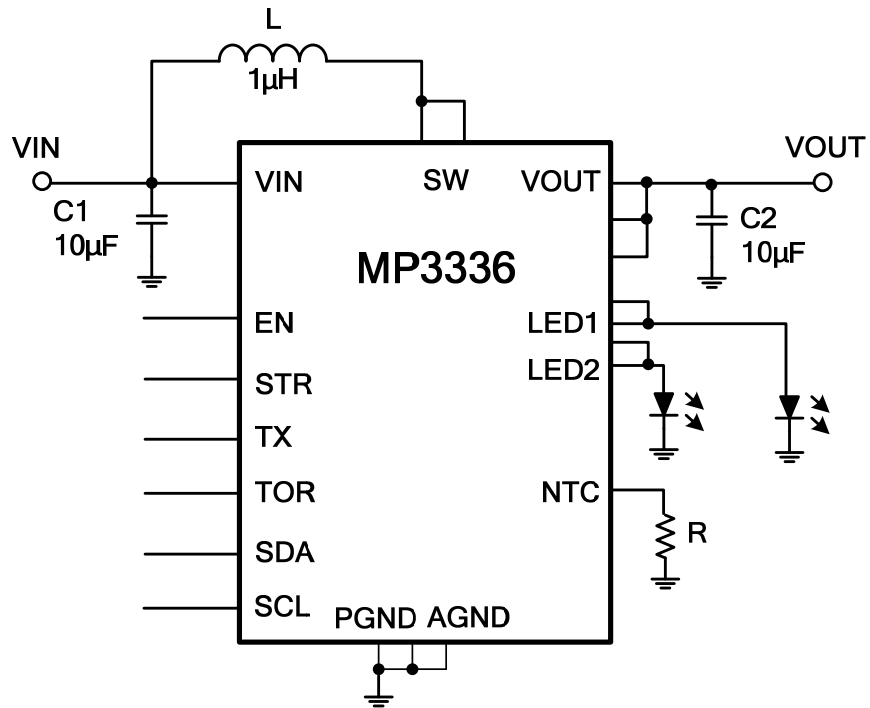

ORDERING INFORMATION

Part Number*	Package	Top Marking
MP3336GC	WLCSP-20 (1.6mmx2.0mm)	See Below

* For Tape & Reel, add suffix -Z (e.g. MP3336GC-Z)

TOP MARKING

—
EFY
LLL

EF: Product code of MP3336GC
 Y: Year code
 LLL: Lot number

PACKAGE REFERENCE

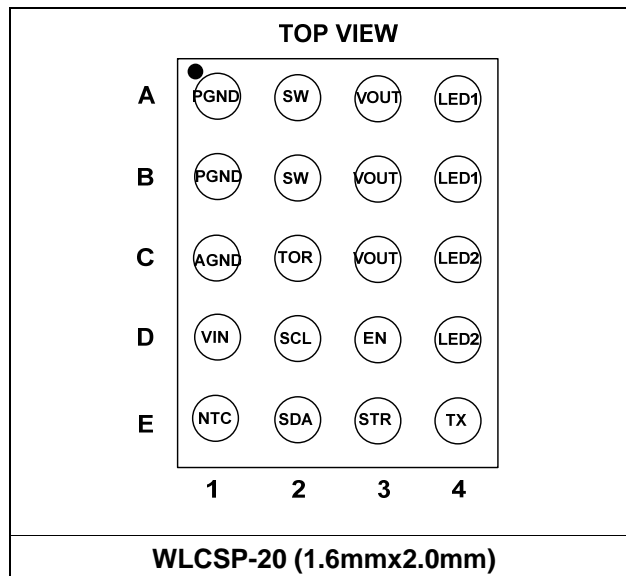

ABSOLUTE MAXIMUM RATINGS ⁽¹⁾

V_{IN}, V_{SW}, V_{OUT}	-0.3V to +6V
NTC	-0.3V to $V_{IN} + 0.3V$
All other pins	-0.3V to +6V
Junction temperature	150°C
Lead temperature	260°C
Continuous power dissipation ($T_A = 25^\circ C$) ⁽²⁾	
WLCSP-20 (1.6mmx2.0mm).....	2.3W

Recommended Operating Conditions ⁽³⁾

Supply Voltage (V_{IN}).....	2.7V to 5.5V
Operating junction temp. (T_J)...	-40°C to +125°C

Thermal Resistance ⁽⁴⁾	θ_{JA}	θ_{JC}	
WLCSP-20 (1.6mmx2.0mm) ...	55 ...	0.5..	°C/W

NOTES:

- 1) Exceeding these ratings may damage the device.
- 2) The maximum allowable power dissipation is a function of the maximum junction temperature T_J (MAX), the junction-to-ambient thermal resistance θ_{JA} , and the ambient temperature T_A . The maximum allowable continuous power dissipation at any ambient temperature is calculated by P_D (MAX) = $(T_J$ (MAX)- T_A)/ θ_{JA} . Exceeding the maximum allowable power dissipation produces an excessive die temperature, causing the regulator to go into thermal shutdown. Internal thermal shutdown circuitry protects the device from permanent damage.
- 3) The device is not guaranteed to function outside of its operating conditions.
- 4) Measured on JESD51-7, 4-layer PCB.

ELECTRICAL CHARACTERISTICS

V_{IN} = 3.6V, T_A = 25°C, unless otherwise noted.

Parameters	Symbol	Condition	Min	Typ	Max	Units
Supply						
Operating input voltage	V _{IN}		2.7		5.5	V
Input UVLO threshold	V _{IN_UVLO}	Rising edge		2.35		V
Input UVLO hysteresis				160		mV
Standby current	I _{Q_STANDBY}	V _{IN} = 2.7V to 5.5V, I ² C active			23	μA
Shutdown current	I _{Q_SD}	V _{IN} = 2.7V to 5.5V, EN = low			2	μA
Operating quiescent current	I _Q	V _{IN} = 3.6V, no switching, pass mode		1.5		mA
Switching Regulator						
Switching frequency	f _s	SW_FS = 11	0.9	1	1.1	MHz
Minimum on time	t _{ON_MIN}			68		ns
NMOS on resistance	R _{DSON_N}	V _{IN} = 3.6V		45		mΩ
PMOS on resistance	R _{DSON_P}	V _{IN} = 3.6V		60		mΩ
Constant DC output voltage	V _{OUT_5V}	5V DC mode		5		V
Inductor current limit	I _{LIMIT}	Code setting = 10, max duty cycle		3.5		A
LED Driver						
Flash current setting	I _{LED_FLASH}	Flash mode, value setting = 00000000		0		mA
		Flash mode, value setting = 00100110	279	300	321	mA
Torch current setting	I _{LED_TORCH}	Assist/torch mode, value setting = 00000000		0		mA
		Assist/torch mode, value setting = 11110000	279	300	321	mA
Current source headroom voltage	V _{HD}	Current = 1250mA ⁽⁵⁾		350		mV
		Current = 200mA		150		mV
Current ramp-up step time	t _{RAMP_UP}	TUP_I = 111		1		μs
		TUP_I = 000		8		μs
Current ramp-down step time	t _{RAMP_DOWN}			1		μs
LED1/2 load balance voltage hysteresis	V _{LED_HYS}			130		mV
Digital Input						
Input logic low voltage					0.4	V
Input logic high voltage			1.2			V
Strobe/torch/TX pull-down resistor				250		kΩ

NOTE:

5) Guaranteed by design.

ELECTRICAL CHARACTERISTICS (continued)
V_{IN} = 3.6V, T_A = 25°C, unless otherwise noted.

Parameters	Symbol	Condition	Min	Typ	Max	Units
Protection						
Flash time-out time	t _{TIMEOUT}	Time setting code = 0001	190	200	210	ms
Input DC current limit	I _{LIMIT_IN}	Current setting code = 0010		1.5		A
Over-voltage threshold	V _{OVP}		5.335	5.5	5.665	V
LED1/2 short detection voltage	V _{LED_ST}			1		V
V _{OUT} short blanking time	T _{OUT_ST}	V _{OUT} < 1V		5		ms
PMOS charge current		V _{OUT} = 1V		250		mA
LED1/2 open detection voltage	V _{LED_OP}			110		mV
Thermal shutdown threshold	T _{I_SD}			150		°C
Adaptive thermal threshold				130		°C
NTC detection voltage	V _{NTC}	Code setting = 001		0.6		V
		Code setting = 111		1.02		V
Low battery threshold	V _{BAT_LOW}	Code setting = 000		3		V
		Code setting = 110		3.6		V
I²C Interface						
Input logic low	V _{IL}				0.4	V
Input logic high	V _{IH}		1.3			V
Output logic low	V _{OL}	I _{LOAD} = 3mA			0.4	V
SCL clock frequency	F _{SCL}				400	kHz
SCL high time	T _{HIGH}		0.6			μs
SCL low time	T _{LOW}		1.3			μs
Data setup time	T _{SU,DAT}		100			ns
Data hold time	T _{HD,DAT}		0		0.9	μs
Setup time for repeated start	T _{SU,STA}		0.6			μs
Hold time for start	T _{HD,STA}		0.6			μs
Bus free time between a start and a stop condition	T _{BUF}		1.3			μs
Setup time for stop condition	T _{SU,STO}		0.6			μs
Rise time of SCL and SDA	T _R		20+0.1*C _B		300	ns
Fall time of SCL and SDA	T _F		20+0.1*C _B		300	ns
Pulse width of suppressed spike	T _{SP}		0		50	ns
Capacitance bus for each bus line	C _B				400	pF

TYPICAL PERFORMANCE CHARACTERISTICS

V_{IN} = 3.6V, L = 1.1μH, I_{1/2_TOR} = 300mA, I_{1/2_FL} = 400mA, I_{1/2_TX} = 400mA, FL_TIM = 200ms, two channels, unless otherwise noted.

Torch/Assist Mode
LED_EN Bit Enable

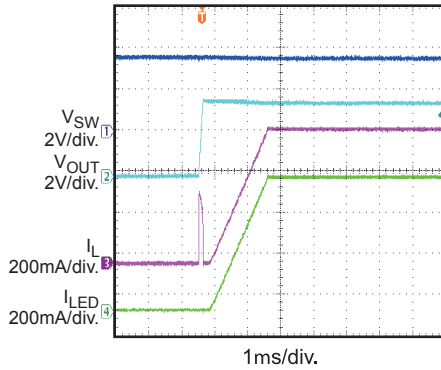

Torch/Assist Mode
LED_EN Bit Disable

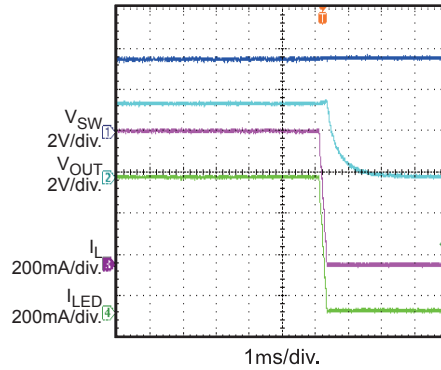

Indicator Mode
I_{LED} Duty = 5/16,
I_{LED_AMPLITUDE/Ch} = 100mA

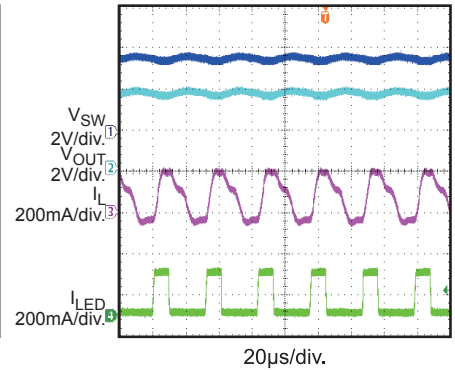

Blinking Mode
Blinking Time = 128ms

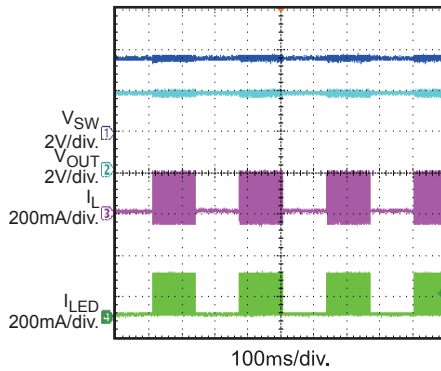

Flash Mode
with Level Trigger Way

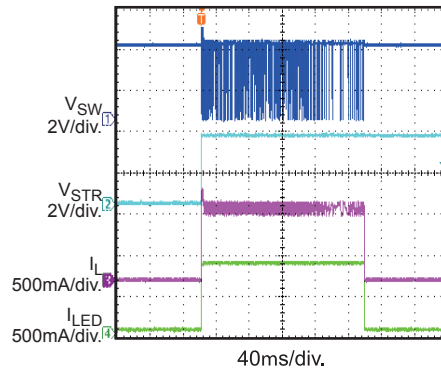

Flash Mode
with Edge Trigger Way

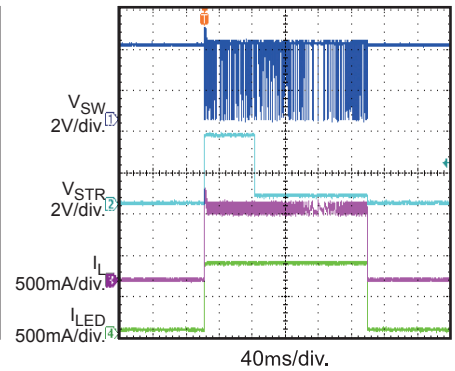

Flash Mode
FL_TIM = 1600ms, I_{1_FL} = 2A,
LED2_EN = 0

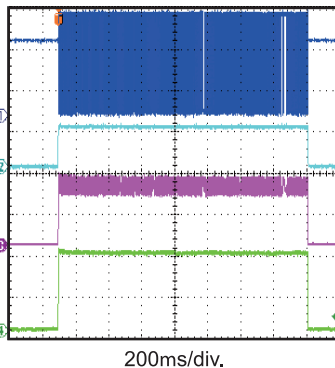

Flash Mode
TX pin with 2Hz, 50% pulse,
I_{1/2_FL} = 1A

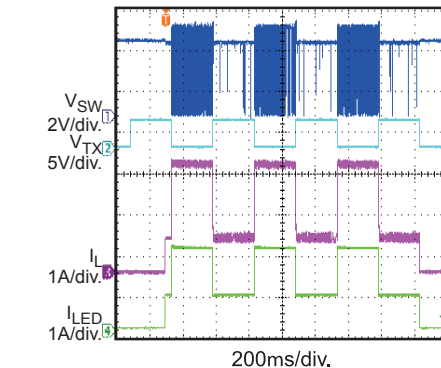

Torch/Assist Mode to Flash Mode
I_{1/2_TOR} = 120mA

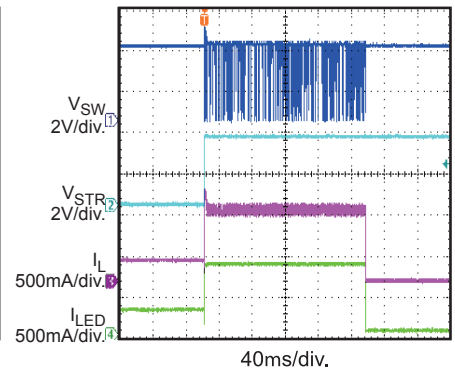

TYPICAL PERFORMANCE CHARACTERISTICS (continued)

V_{IN} = 3.6V, L = 1.1μH, I_{1/2_TOR} = 300mA, I_{1/2_FL} = 400mA, I_{1/2_TX} = 400mA, FL_TIM = 200ms, two channels, unless otherwise noted.

Load Balance

Set BAL_ON Bit from 0 to 1

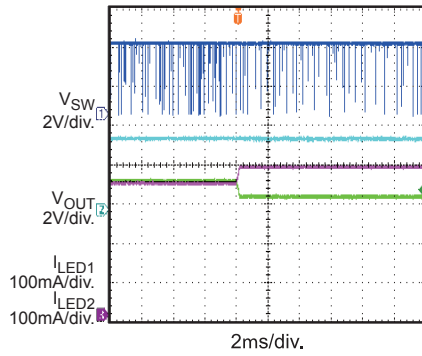
5V_DC Mode

V_{OUT} to GND with 75Ω Resistor

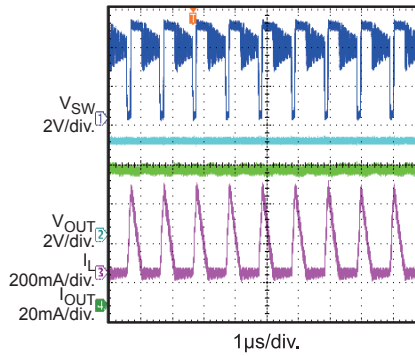
Short LED to GND Protection

Short One Channel when Working

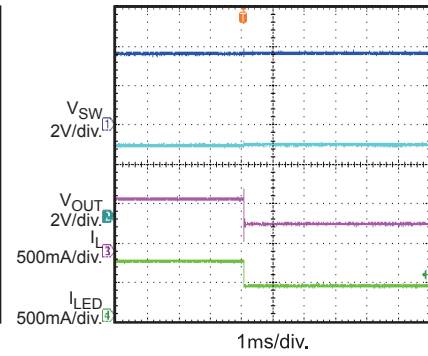
Open LED Protection

Open one Channel when Working

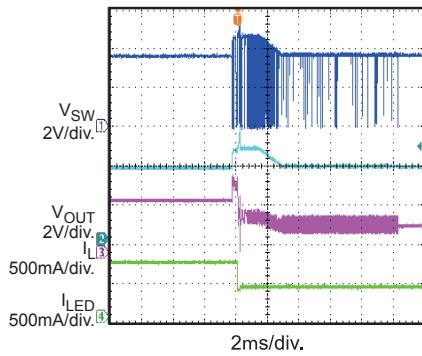
V_{OUT} to GND Short Protection

when Working

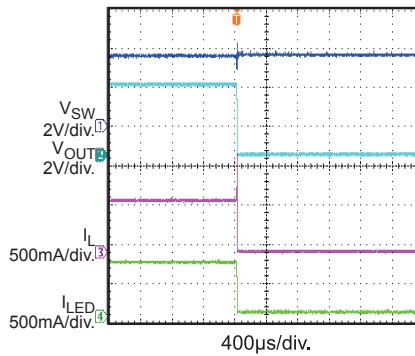
Thermal Protection

Flash Mode, Set LED_OTAD=1, I_{1/2_FL} = 600mA, FL_TIM = 1600ms

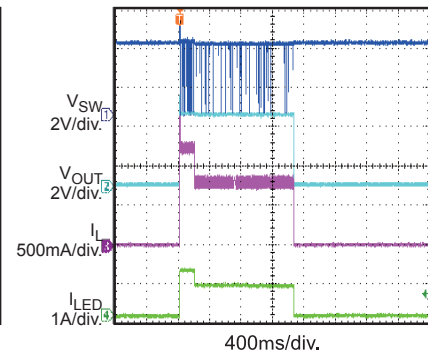
Thermal Protection

Assist Mode, Set LED_OTAD=0

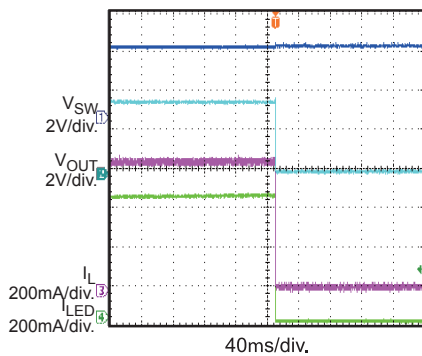
NTC Detection

Set NTC_WD = 0.88V, Set LED_T_SD = 1

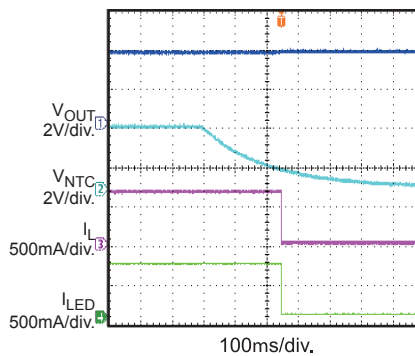

PIN FUNCTIONS

Pin #	Name	Description
A4, B4	LED1	Current source for LED1. Connect the anode of the LED to LED1.
C4, D4	LED2	Current source for LED2. Connect the anode of the LED to LED2.
E4	TX	Synchronization input signal for RF transmission signal. TX is pulled low internally if left floating.
A3, B3,C3	VOUT	Boost converter output.
D3	EN	IC enable.
E3	STR	Strobe signal input. STR synchronizes the flash pulse to the image capture. STR is pulled low internally if left floating.
A2, B2	SW	Boost converter switching node.
C2	TOR	Torch mode input signal. TOR is pulled low internally if left floating.
D2	SCL	I²C interface clock signal.
E2	SDA	I²C interface data.
A1, B1	PGND	Power GND.
C1	AGND	Analog GND.
D1	VIN	Input supply. VIN provides power for the internal power and logic circuits. VIN must be bypassed locally.
E1	NTC	LED temperature detection. Connect NTC to a negative thermal coefficient resistor when in use. Float NTC when not in use.

BLOCK DIAGRAM

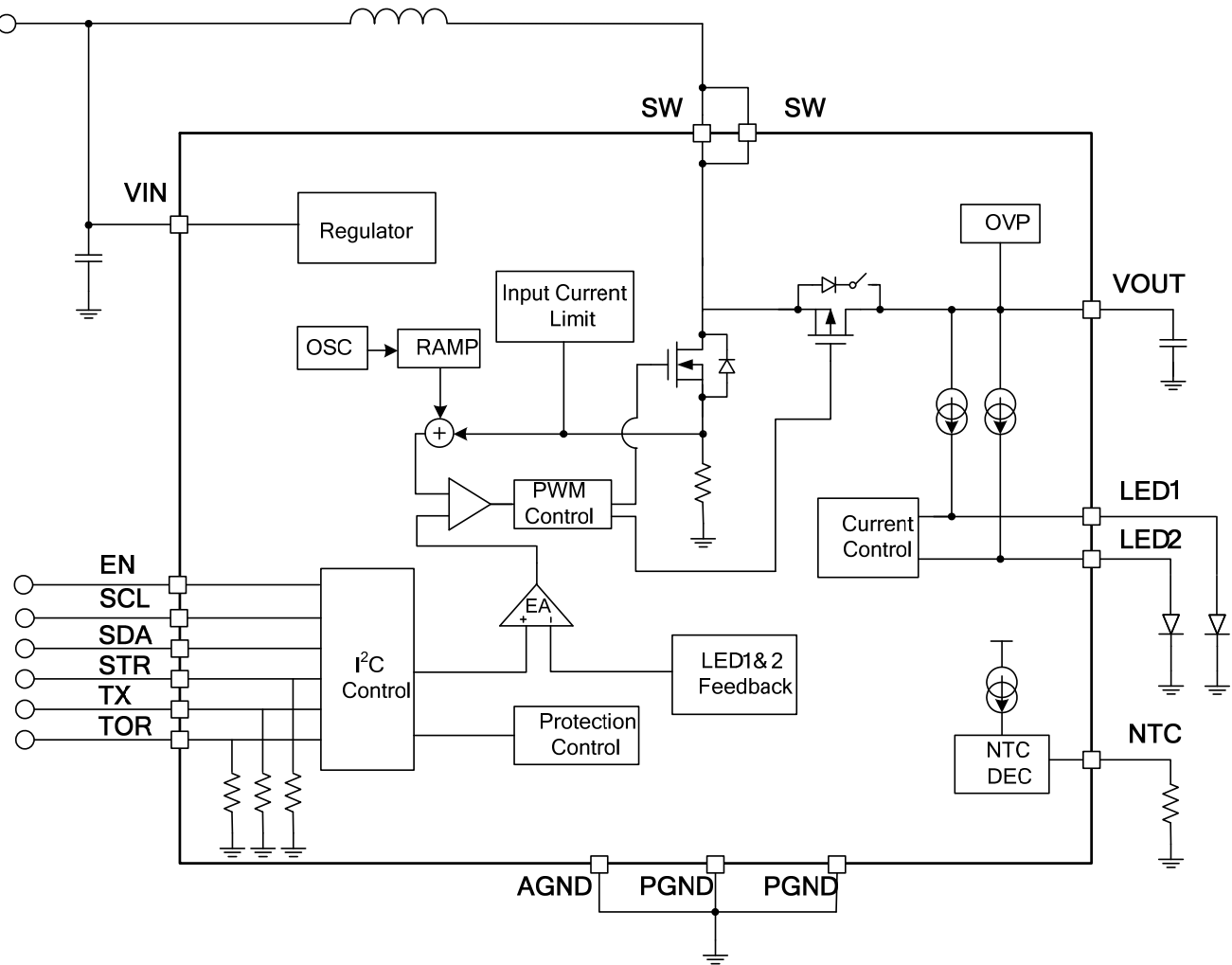

Figure 1: Functional Block Diagram

OPERATION

The MP3336 is a dual-channel, LED driver with I²C interface that supports image capture for camera flash. The MP3336 can work in flash mode, assist mode, torch mode, indicator mode, and fixed 5V DC output mode. Table 1 shows how to set these operation modes.

LED Driver Operation

The MP3336 is a synchronous, current-mode, PWM, boost converter that can work with 1/2/3/4MHz. The MP3336 regulates the boost loop by detecting and controlling the headroom voltage across the current source (V_{OUT}-V_{LED1/2}).

When the device is enabled by LED_EN, the synchronous PMOS works with a 250mA current source first to charge the output capacitor until V_{OUT} rises above 2.3V. The device changes to boost switching mode if the voltage across the current source is less than the target reference, which is set by V_{TH_PAS}. If V_{IN} is very close to V_{OUT}, the IC switches to boost switching mode and pass mode automatically to minimize power loss. In pass mode, the synchronous PMOS is fully turned on. During the current start-up, the current ramps up step-by-step smoothly until the target setting current is reached.

Table 1: Operation Mode Setting

Configuration							Mode
TX	TOR	STR ⁽⁶⁾	LED1/2_EN	STR_MOD	5V_MOD	LED_MOD	
X	High	Float	1	X	X	00	Torch
X	X	Float	1	X	X	10	Assist
X	X	X	1	X	X	01	Indicator
0	X	High	1	1	X	11	Flash
1	X	High	1	1	X	11	Flash
X	X	X	1	0	X	11	Flash
X	X	X	X	X	1	X	5V

NOTE:

6) STR is high active when STR_POL = 1. STR is low active when STR_POL = 0. Table 1 is based on STR_POL = 1.

Standby Mode

By default, if V_{IN} is higher than UVLO and EN is pulled high, the device enters standby mode. In this mode, only the I²C is active and ready to communicate with the host.

Torch Mode

In standby mode, if TOR goes from low to high, the device changes to torch mode and the current ramps up step-by-step to the target current after setting the LED1/2_EN bits to 1. The target current for the LED can be set through registers I1_TOR and I2_TOR. The ramp-up slew rate can be set by the register TUP_I. The current can be disabled by pulling TOR to low or by setting the LED1/2_EN bits to 0. These two bits control the two LED current sources respectively. By pulling TOR low, the LED1/2_EN and LED_MOD bits reset to the default automatically if LED_SD is 0 (see Figure 2).

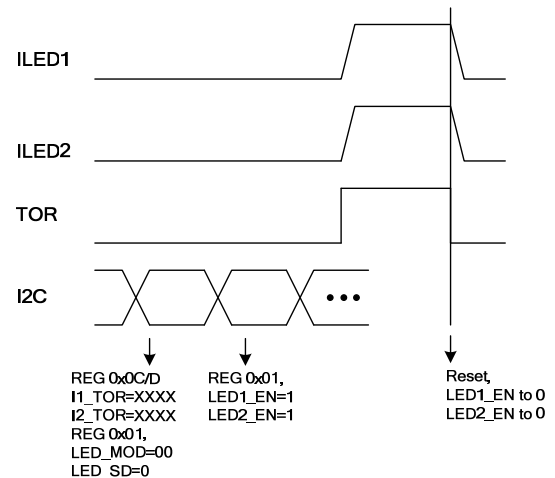

Figure 2: Torch Mode

Assist Mode

To enter assist mode, set the LED_MOD register to 10 and LED1/2_EN to 1. The current ramps up to the target value, which is set by I1_TOR and I2_TOR. The ramp-up slew rate can be set by register TUP_I. The current can be disabled by switching to standby mode or by

setting the LED1/2_EN bits to 0. These two bits control the two LED current sources respectively (see Figure 3).

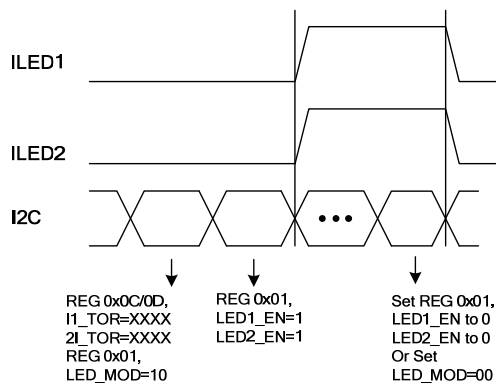

Figure 3: Assist Mode

Indicator Mode

When LED_MOD is set to 01 and LED_EN1/2 is set to 1, the MP3336 enters indicator mode, which provides a low-current output (see Figure 4). In this mode, the driver current sources work in a 31.5kHz PWM dimming mode. The current amplitude can be set by I1_TOR and I2_TOR, while the indicator current step ramps up more quickly at a rate of 7.84mA/step, compared to torch mode's ramp-up rate of 1.25mA/step. The final amplitude in this mode can be calculated with Equation (1):

$$7.84\text{mA} \times I1/2_TOR \quad (1)$$

The duty cycle is set by the INDI_PWM register. When disabled, switch to standby mode or set the LED1_EN and LED2_EN bits to 0.

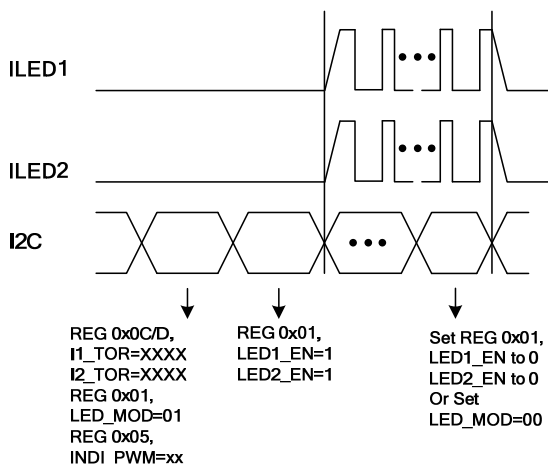

Figure 4: Indicator Mode

In indicator mode, the MP3336 can also work in blinking mode. If blinking is enabled, the IC

works in indicator mode during the blinking time, and the LED current source is disabled during the blinking time (see Figure 5). The blinking time is set by the TBK0-1 bits in register 0FH.

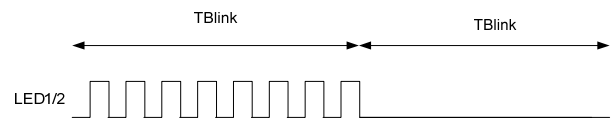

Figure 5: Blinking Time

Flash Mode

The device can work in flash mode in three ways: hardware and level trigger mode, hardware and edge trigger mode, and software and edge trigger mode. All of the below description are based on bit STR_POL = 1. The default high level is active for STR. When STR_POL is set to 0, STR is low active.

1. Hardware and Level Trigger Mode

In this mode, STR_MOD = 1, STR_LV = 1, LED1/2_EN = 1, LED_MOD = 11. The flash current begins to ramp up after STR goes high. The current is set by I1_FL and I2_FL, and the ramp-up time is set by TUP_I. The flash current ends when STR is pulled low or when the flash timer ends. After flash, LED_MOD is reset to standby mode, and LED1/2_EN is set to 0 if LED_SD = 0. If LED_SD = 1, LED_MOD and LED1/2_EN are not reset. The LED1 and LED2 current sources are controlled by the LED1_EN and LED2_EN bits respectively. If the STR is pulled low before the flash timer ends, the flash current shuts down at the STR falling edge (see Figure 6). Conversely, if the flash timer set by FL_TIM ends before STR goes low, the flash current terminates immediately. The time-out indicator bit FT_TO is set to 1 and is not cleared until it is read back or the input power resets (see Figure 7).

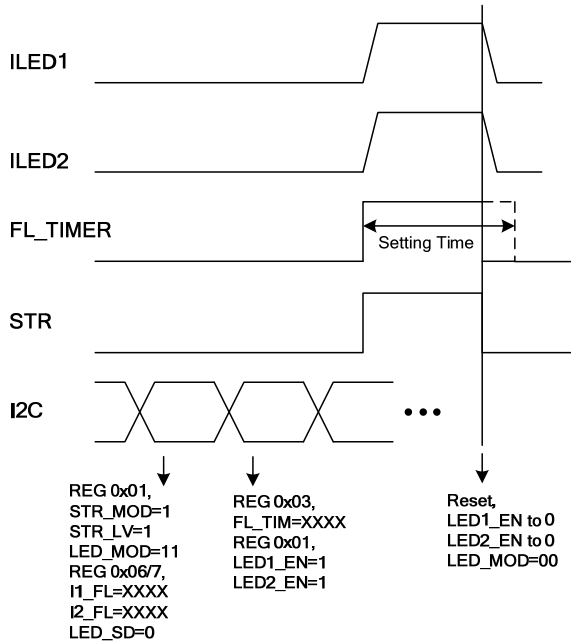

Figure 6: Hardware and Level Trigger Flash Mode without Time-Out

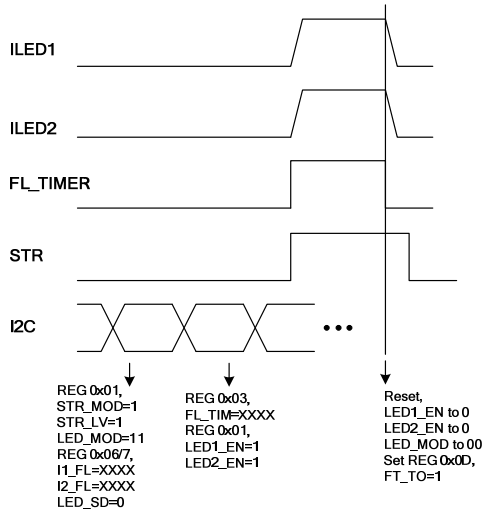

Figure 7: Hardware and Level Trigger Flash Mode with Time-Out

2. Hardware and Edge Trigger Mode

In this mode, STR_MOD = 1, STR_LV = 0, LED1/2_EN = 1, and LED_MOD = 11. The flash current begins to ramp up after STR goes high. The current is set by I1_FL and I2_FL, and the ramp-up time is set by TUP_I. The flash current ends when the flash timer set by FL_TIM ends. After the flash, the LED_MOD is reset to standby mode, and LED1/2_EN is set to 0 if LED_SD = 0. If LED_SD = 1, the mode and LED_MOD and LED1/2_EN are not reset. The

LED1 and LED2 current sources are controlled by the LED1_EN and LED2_EN bits respectively (see Figure 8).

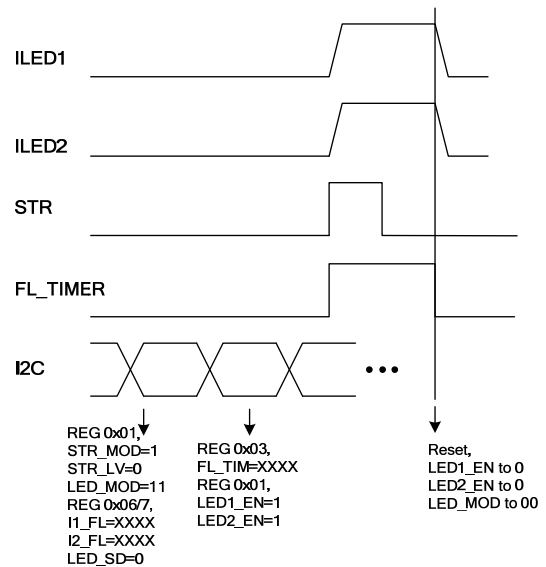

Figure 8: Hardware and Edge Trigger Flash Mode

3. Software and Edge Trigger Mode

In this mode, without STR, STR_MOD = 0, LED1/2_EN = 1, and LED_MOD = 11. The current is set by I1_FL and I2_FL, and the ramp-up time is set by TUP_I. The flash current ends when the flash timer set by FL_TIM ends. After the flash, the LED_MOD is reset to standby mode if LED1/2_EN is set to 0 with LED_SD = 0. If LED_SD = 1, the LED_MOD is not reset if ILED1/2_EN is set to 0. The LED1 and LED2 current sources are controlled by the LED1_EN and LED2_EN bits respectively (see Figure 9).

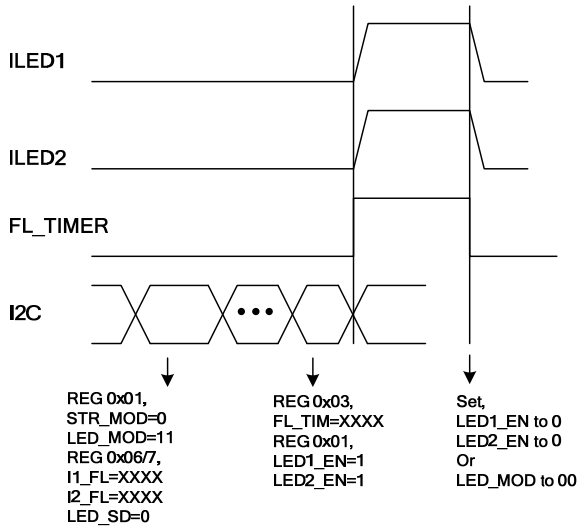

Figure 9: Software and Edge Trigger Flash Mode Torch Mode to Flash Mode

The MP3336 can switch to flash mode from torch mode directly when STR goes from low to high if STR_MOD = 1. After flash, the operation functions the same way as in flash mode (see Figure 10).

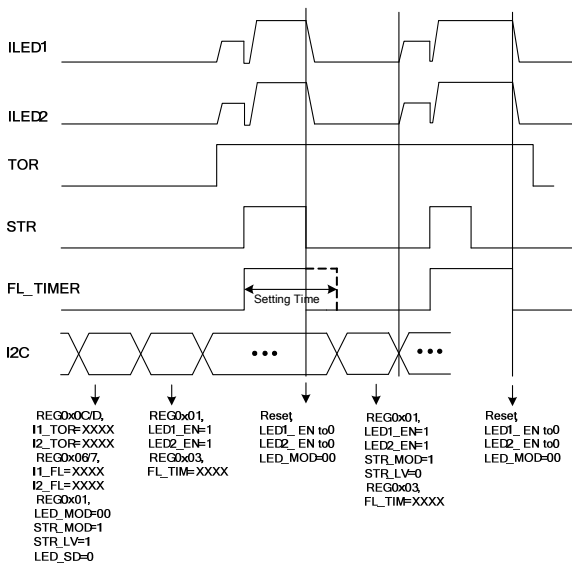

Figure 10: Torch Mode to Flash Mode

Assist Mode to Flash Mode

During assist light mode, the device can switch to flash mode from assist mode directly when STR goes from low to high if STR_MOD = 1. After flash, the operation functions the same way as in flash mode (see Figure 11).

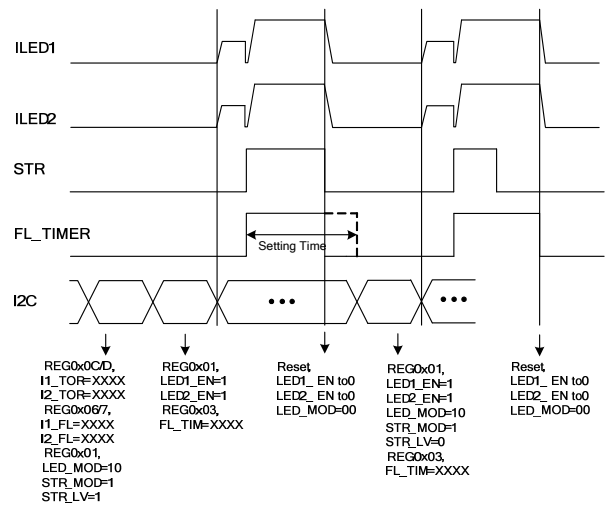

Figure 11: Assist Mode to Flash Mode

5V DC Output Mode

If 5V_MOD is set to 1, the device can work in a fixed 5V output mode, and the control loop is taken over by the voltage loop (see Figure 12). The LED current sources can still output a current if the mode conditions are met as described above. Care must be taken to ensure that the thermal condition is normal, since 5V directly powers the LED. It is recommend to set LED1/2_EN to 0 during 5V mode.

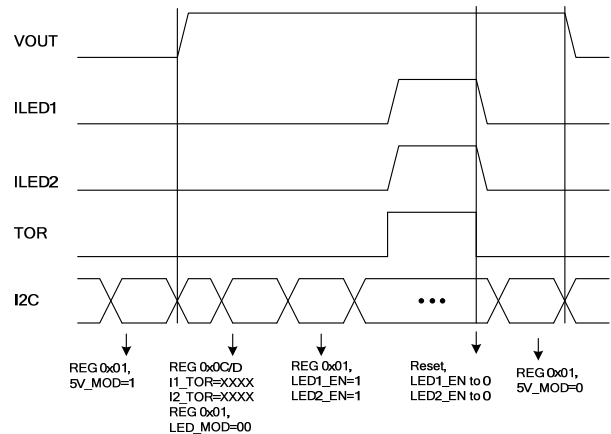

Figure 12: 5V DC Mode

Maximum Switching Frequency Setting

The maximum switching frequency can be selected by the SW_FS bits when working in boost mode. 1 /2 /3 /4MHz can be selected to optimize efficiency.

Switching Frequency Fold-back

When the max switching frequency is set to 2/3/4MHz in switching mode, if the voltage across the current source is larger than the value set by the register bits VTH_PAS, the IC switches to 1MHz to improve efficiency and EMI. With 1MHz, if the voltage across the current source is still larger than the value set by the register bits VTH_PAS, the IC can stretch the frequency down until it reaches about 100kHz with FS_SD = 0. If the LED load becomes lighter and the input voltage increases further, the IC switches to pass mode from 100kHz. With FS_SD = 1, the IC switches directly to pass mode from 1MHz.

Load Balancing

To improve efficiency, the device provides load balancing to prevent unbalanced forward voltage drops between the dual LEDs (see Figure 13). To enable this function, the bit BAL_ON must be set to 1. Supposing $V_{LED1} > V_{LED2} + V_{LED_HYS}$, the LED1 current drops step by step while the LED2 current rises step by step. Finally, $|V_{LED1} - V_{LED2}| < V_{LED_HYS}$ or $I_{LED1} < 90\%I_{LED2}$.

However, the maximum adjustment range of each LED current is limited to 10%. Because of the limitation, if there is a large difference between V_{LED1} and V_{LED2} , the load balance function cannot make $|V_{LED1} - V_{LED2}|$ drop below V_{LED_HYS} , but it is still helpful to further reduce the voltage difference and improve efficiency.

Conversely, if $V_{LED2} > V_{LED1} + V_{LED_HYS}$, the operation is the same.

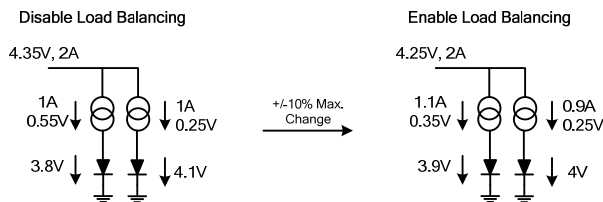

Figure 13: Load Balancing

LED Output Current Reduction

When the MP3336 works in flash mode, output current reduction may occur due to the following three conditions:

1. TX is High

During flash mode, if TX goes from low to high, the flash current drops to the current set by I_TX in under 5μs and sets the FT_TX bit to 1. If TX goes low, the current ramps up to the flash current again (see Figure 14).

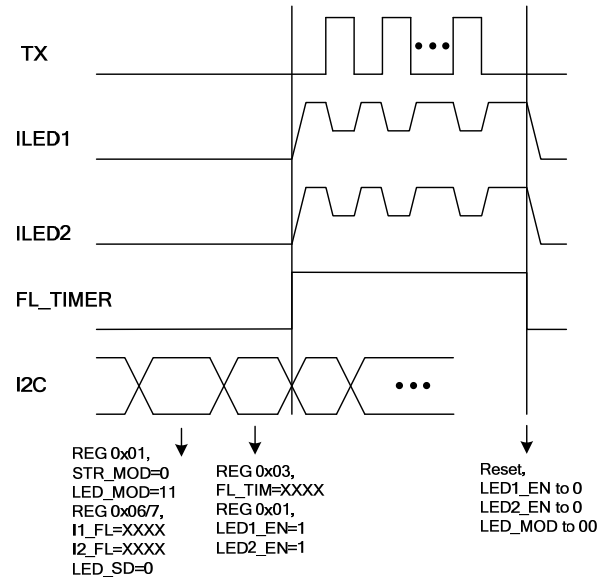

Figure 14: Flash Mode with TX Pulse

2. Input DC Current Limit is Triggered

If the input DC current limit set by IL_DC register is not sufficient, a current reduction may occur. The actual current in the IFL_ACT register can be read back during flash.

Input DC Current Limit Protection

The MP3336 uses the input DC current limit protection to avoid drawing too much current from the battery. This current limit can be programmed by the IL_DC register from 1A to 4.2A with 250mA/step when $IL_DC < 3A$ and with 300mA/step when $IL_DC > 3A$. If the input current hits the input current limit threshold, the LED output current stops and holds until the input current limit drops below the current limit threshold. The fault bit FT_IDC is set to 1 if the input current limit is triggered. The fault bit remains until it is read back or the input power is reset. The input current limit protection is useful in boost mode because it senses the current of the low-side MOSFET.

3. Low Battery Voltage Threshold Is Triggered

During flash pulse, if the battery voltage drops below the threshold set by VBL_RUN, the current reduces step by step until the battery voltage rises up to the set low battery voltage threshold. The actual current in the IFL_ACT register can read back during flash and the minimum current caused by the current reduction in IFL_MIN can be read back after flash.

Low Battery Voltage Protection

The device provides low battery voltage protection in flash mode in the following ways:

1. Before flash, if VBL_SD = 1, and the input voltage is lower than the threshold set by VBL_RUN, the device remains disabled and sets the fault bit FT_VBATL to 1. If VBL_SD = 0, the device ramps to the current set by I_TX and sets the fault bit FT_VBATL to 1. The fault bit is cleared after it is read back or when the input power resets.
2. During flash start-up, if the input voltage is lower than the threshold set by VBL_RUN, the current stops ramping. The fault bit FT_VBATL is set. During flash pulse, if the input voltage is lower than the threshold set by VBL_RUN, the current ramps down step by step. The fault bit is set until it is read back or when the input power resets.

After flash, the minimum current caused by the current reduction can be read back through the IFL_MIN register. The IFL_MIN value holds until the next flash occurs or until the power resets. The actual current can be read back through IFL_ACT during flash. This function is useful for determining how much flash current can be drawn from the battery (see Figure 15).

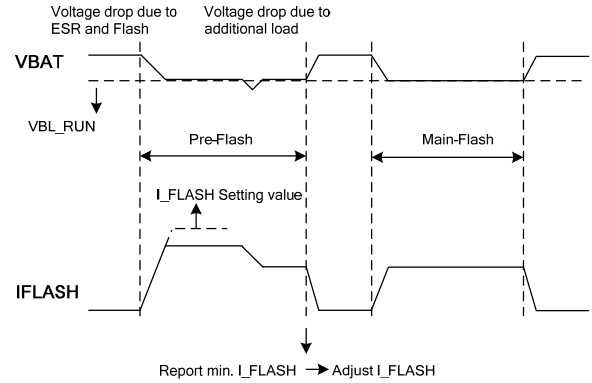

Figure 15: Pre-Flash under Low Battery

NTC Detection

If the register NTC_WD is set to enable NTC detection, the NTC sources a constant 35µA current. If the voltage across the NTC resistor drops below the threshold set by NTC_WD, the internal fault bit FT_LEDHOT is set to 1 and the modes are reset to standby mode if LEDT_SD = 1. If LEDT_SD = 0, the mode setting is not reset after the fault bit is set. The fault bit remains until it is read back or the power resets. It is recommended to float NTC if this function is not being used.

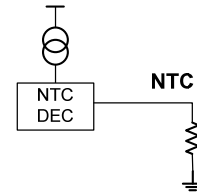

Figure 16: NTC Detection

VOUT-GND Short Protection

If VOUT < 1V, the device stops switching and disconnects the synchronous PMOS to prevent a large current from being drawn from the battery. Set the FT_VOOSC bit to 1 and reset the mode setting. The fault bit remains until it is read back or the power resets.

LED1/2-GND Short Protection

If LED1 < 1V and ILED1 > 5mA, or LED2 < 1V and ILED2 > 5mA, the IC marks off the current source and sets the fault bit FT_LEDSC but continues switching. If both current sources are marked off, the device stops switching and the mode setting is reset. The fault bit FT_LEDSC is 1 until it is read back or the power resets. If LED_EN1 is set to 0, the feedback of the current source 1 is not involved

in the loop control, and fault detections on this channel are also disabled.

LED1/2 Open Protection

If $V_{OUT} - V_{LED1/2} < 110\text{mV}$ and $V_{OUT} > 5.5\text{V}$, the IC marks off the fault current source and sets the fault bit FT_OVP but continues switching. If both current sources are marked off, the device stops switching and the mode setting is reset. The fault bit FT_OVP is 1 until it is read back or the power resets. If LED_EN1 is set to 0, the feedback of the current source 1 is not involved in loop control, and fault detection on this channel is also disabled.

Output Over-Voltage Protection (OVP)

If $V_{OUT} > 5.5\text{V}$, the device stops switching and resumes normal condition until V_{OUT} drops below 5.2V. The fault bit FT_OVP is 1 until it is read back or the power resets.

Junction Over-Temperature Protection

If LED_OTAD = 1, the flash current drops to the current set by I_TX when $T_J > 130^\circ\text{C}$. The fault bit FT_OTP is set to 1. If $T_J > 150^\circ\text{C}$, the device stops switching and resets LED_MOD and LED_EN1/2. The fault bit FT_OTP must be cleared to 0 by a read-back or a power reset.

Time-Out Protection

If the device works in one of the flash modes—hardware and level trigger mode—time-out protection may be triggered. When the STR input pulse is longer than the flash timer set by FL_TIM, the device is disabled once the timer ends. The device stops switching and resets the mode setting, and the fault bit is 1 until it is read back or the power is reset before restarting.

Under-Voltage Lockout (UVLO) Protection

If VIN drops below the UVLO threshold, the device stops and all of the registers are reset to default.

I²C Interface Register Description

I²C Chip Address

After the start condition, the I²C-compatible master sends a seven-bit address followed by an eighth read (Read: 1) or write (Write: 0) bit. The following bit indicates the register address to or from which the data is written or read. The I²C address of the MP3336 is 0x27.

0	1	0	0	1	1	1	R/W
---	---	---	---	---	---	---	-----

I²C Compatible Device Address

Register Mapping

Add	Reg	D7	D6	D5	D4	D3	D2	D1	D0
00H	Chip ID	DEV_ID4	DEV_ID3	DEV_ID2	DEV_ID1	DEV_ID0	REV_ID2	REV_ID1	REV_ID0
01H	Mode	STR_LV	STR_MOD	STR_POL	LED1_EN	LED2_EN	LED_MOD1	LED_MOD0	5V_MOD
02H	Peak current	NTC_WD2	NTC_WD1	NTC_WD0	IL_PEAK1	IL_PEAK0	FS_SD	BAL_ON	NA
03H	Flash timer	FL_TIM3	FL_TIM2	FL_TIM1	FL_TIM0	LED_SD	LEDT_SD	SW_FS1	SW_FS0
04H	Low battery voltage	VBL_RUN2	VBL_RUN1	VBL_RUN0	VBL_SD	IL_DC3	IL_DC2	IL_DC1	IL_DC0
05H	Indicator	LED_OTAD	TUP_I2	TUP_I1	TUP_I0	VTH_PAS1	VTH_PAS2	INDI_PWM1	INDI_PWM0
06H	LED1 flash current	I1_FL7	I1_FL6	I1_FL5	I1_FL4	I1_FL3	I1_FL2	I1_FL1	I1_FL0
07H	LED2 flash current	I2_FL7	I2_FL6	I2_FL5	I2_FL4	I2_FL3	I2_FL2	I2_FL1	I2_FL0
08H	TX1MAS K current	I1_TX7	I1_TX6	I1_TX5	I1_TX4	I1_TX3	I1_TX2	I1_TX1	I1_TX0
09H	TX2MAS K current	I2_TX7	I2_TX6	I2_TX5	I2_TX4	I2_TX3	I2_TX2	I2_TX1	I2_TX0
0AH	Actual flash	IFL_ACT7	IFL_ACT6	IFL_ACT5	IFL_ACT4	IFL_ACT3	IFL_ACT2	IFL_ACT1	IFL_ACT0
0BH	Minimum flash	IFL_MIN7	IFL_MIN6	IFL_MIN5	IFL_MIN4	IFL_MIN3	IFL_MIN2	IFL_MIN1	IFL_MIN0
0CH	LED1 torch	I1_TOR7	I1_TOR6	I1_TOR5	I1_TOR4	I1_TOR3	I1_TOR2	I1_TOR1	I1_TOR0
0DH	LED2 torch	I2_TOR7	I2_TOR6	I2_TOR5	I2_TOR4	I2_TOR3	I2_TOR2	I2_TOR1	I2_TOR0
0EH	Fault indication	FT_VBATL	FT_OVP	FT_VOOSC	FT_LEDSC	FT_OTP	FT_TO	FT_TX	FT_IDC
0FH	Fault indication	TBK1	TBK0	NA	NA	BAL_1AB2	BAL_2AB1	FT_LEDHOT	FT_LEDOP

Table 2: Chip ID Register

Addr: 0x00				
Bit	Bit Name	Access	Default	Description
2:0	REV_ID	R	011	Revision ID.
7:3	DEV_ID	R	00111	Device ID.

Table 3: Mode Setting Register

Addr: 0x01				
Bit	Bit Name	Access	Default	Description
7	STR_LV	RW	1	Flash mode trigger mode with strobe pin signal. 0 = edge sensitive 1 = level sensitive
6	STR_MOD	RW	1	Strobe pin enable bit. 0 = software enable 1 = hardware enable
5	STR_POL	RW	1	Strobe pin signal input active polarity. 0 = active low 1 = active high
4	LED1_EN	RW	0	LED1 current source enable bit. 0 = LED current sink disable 1 = enable
3	LED2_EN	RW	0	LED2 current source enable bit. 0 = LED current sink disable 1 = enable
2:1	LED_MOD	RW	00	Device mode setting bits. 00 = standby/torch mode 01 = indicator mode 10 = assist mode 11 = flash mode
0	5V_MOD	RW	0	5V DC output enable bit. 0 = disable 1 = enable

Table 4: NTC Detection and Current Limit Setting Register

Addr: 0x02				
Bit	Bit Name	Access	Default	Description
7:5	NTC_WD	RW	000	NTC pin detection window. 000 = off 001 = 0.6V 010 = 0.67V 111 = 1.02V
4:3	IL_PEAK	RW	01	Inductor current limit setting bits. 00 = 2A 01 = 2.5A 10 = 3.5A 11 = 4.5A
2	FS_SD	RW	0	Disable switching frequency stretching down from 1MHz if VIN is close to VOUT. 0 = enable F _S stretching down function 1 = disable F _S stretching down function
1	BAL_ON	RW	0	Load balance matching enable bit. 0: LED voltage mismatch auto-balance disabled 1: LED voltage mismatch auto-balance enabled
0	NA	RW	NA	Reserved.

Table 5: Flash Timer Setting Register

Addr: 0x03				
Bit	Bit Name	Access	Default	Description
7:4	FL_TIM	RW	0001	Flash timer setting bits. 100ms to 1600ms, 100ms/step. 0000 = 100ms 0001 = 200ms 1111 = 1600ms
3	LED_SD	RW	0	LED_MOD and LED1/2_EN resetting control bit. 0 = reset LED_MOD and LED1/2_EN to default value after flash or torch 1 = no reset
2	LEDT_SD	RW	0	LED_MOD and LED1/2_EN resetting control bit when NTC fault occurs. 0 = no reset and device continues 1 = reset and device stops
1:0	SW_FS	RW	00	Max Switching frequency setting bits. 00 = 4MHz 01 = 3MHz 10 = 2MHz 11 = 1MHz

Table 6: Low Battery Voltage Setting Register

Addr: 0x04				
Bit	Bit Name	Access	Default	Description
7:5	VBL_RUN	RW	111	Low battery voltage setting bits. If VIN drops below this voltage during start-up, the current ramping stops. If, during flash current pulse, the current is decreased until VIN is higher than its threshold. It works only in flash mode. 0.1V per step. 000 = 3V 001 = 3.1V 110 = 3.6V 111 = disabled
4	VBL_SD	RW	1	1 = device disabled when VIN is less than the threshold set by VBL_RUN before flash 0 = enable and current ramps up to current set by I_TX
3:0	IL_DC	RW	0100	Input DC current limit setting bits. 1A to 4.2A. 1A to 3A: 250mA/step 0000 = 1A 1000 = 3A >3A: 300mA/step 1001 = 3.3A 1100 = 4.2A

Table 7: Indicator Register

Addr: 0x05				
Bit	Bit Name	Access	Default	Description
7	LED_OTAD	RW	0	Adaptive thermal flash current control bit. 1 = current reduces to the current set by I_TX when T _J > 130°C 0 = disable when T _J > 150°C
6:4	TUP_I	RW	001	Current ramp-up time per step. 000 = 8μs 001 = 7μs 111 = 1μs
3:2	VTH_PAS	RW	01	Define the threshold when F _S drops down to 1MHz or switches to pass mode from boost mode. 00 = 300mV 01 = 450mV 10 = 600mV 11 = 750mV
1:0	INDI_PWM	RW	00	PWM duty cycle of 31.5kHz in indicator mode. 00 = 2/16 01 = 3/16 10 = 4/16 11 = 5/16

Table 8: LED1 Flash Current Setting Register

Addr: 0x06				
Bit	Bit Name	Access	Default	Description
7:0	I1_FL	RW	00110011	LED1 flash current setting bits. 0 to 2000mA, 7.84mA/step (default 00110011 = 400mA). 00000000 = 0mA 11111111 = 2000mA

Table 9: LED2 Flash Current Setting Register

Addr: 0x07				
Bit	Bit Name	Access	Default	Description
7:0	I2_FL	RW	00110011	LED2 flash current setting bits. 0 to 2000mA, 7.84mA/step (default 00110011 = 400mA). 00000000 = 0mA 11111111 = 2000mA

Table 10: TX Current Setting Register for LED1

Addr: 0x08				
Bit	Bit Name	Access	Default	Description
7:0	I1_TX	RW	00110011	Define the LED1 flash current in flash mode if TX is high. 0 to 2000mA, 7.84mA/step (default 00110011 = 400mA). 00000000 = 0mA 11111111 = 2000mA

Table 11: TX Current Setting Register for LED2

Addr: 0x09				
Bit	Bit Name	Access	Default	Description
7:0	I2_TX	RW	00110011	Define the LED2 flash current in flash mode if TX is high. 0 to 2000mA, 7.84mA/step (default 00110011 = 400mA). 00000000 = 0mA 11111111 = 2000mA

Table 12: Actual Flash LED Current Register

Addr: 0x0A				
Bit	Bit Name	Access	Default	Description
7:0	IFL_ACT	R	00000000	The actual flash current in flash mode. 0 to 2000mA, 7.84mA/step. 00000000 = 0mA 11111111 = 2000mA

Table 13: Minimum Flash LED Current Register

Addr: 0x0B				
Bit	Bit Name	Access	Default	Description
7:0	IFL_MIN	R	00000000	The minimum flash current caused by low battery voltage current reduction in flash mode. 0 to 2000mA, 7.84mA/step. 00000000 = 0mA 11111111 = 2000mA

Table 14: LED1 Torch Current/Indicator Amplitude Setting Register

Addr: 0x0C				
Bit	Bit Name	Access	Default	Description
7:0	I1_TOR	RW	00010101	<p>In torch mode: LED1 current setting bits. 0 to 319mA, 1.25mA/step (default 00010101 = 26mA). 00000000 = 0mA 11111111 = 319mA</p> <p>In indicator mode: LED1 current amplitude. 7.84mA/step (default 00010101 = 165mA). 00000000 = 0mA 00000001 = 7.84mA.....</p>

Table 15: LED2 Torch Current/Indicator Amplitude Setting Register

Addr: 0x0D				
Bit	Bit Name	Access	Default	Description
7:0	I2_TOR	RW	00010101	<p>In torch mode: LED2 current setting bits. 0 to 319mA, 1.25mA/step (default 00010101 = 26mA). 00000000 = 0mA 11111111 = 319mA</p> <p>In indicator mode: LED2 current amplitude. 7.84mA/step (default 00010101 = 165mA). 00000000 = 0mA 00000001 = 7.84mA.....</p>

Table 16: Fault and Flag Indication Register

Addr: 0x0E				
Bit	Bit Name	Access	Default	Description
7	FT_VBATL	R	0	Low battery voltage fault bit. 0 = no fault 1 = fault
6	FT_OVP	R	0	Output over-voltage fault bit. 0 = no fault 1 = fault
5	FT_VOOSC	R	0	VOUT-GND short fault bit. 0 = no fault 1 = fault
4	FT_LEDSC	R	0	LED short fault bit. 0 = no fault 1 = fault
3	FT_OTP	R	0	Junction over-temperature fault bit. 0 = no fault 1 = fault
2	FT_TO	R	0	Flash time-out indicator bit. 0 = no fault 1 = fault
1	FT_TX	R	0	TX high indicator bit. 0 = no fault 1 = fault
0	FT_IDC	R	0	Input DC current limit fault bit. 0 = no fault 1 = fault

Table 17: Fault Indication and Blink Time Setting Register

Addr: 0x0F				
Bit	Bit Name	Access	Default	Description
7:6	TBK	R/W	01	Blinking time setting bits in indicator mode. 00: no blinking, LED remains on 01: Tblink = 128ms 10: Tblink = 256ms 11: Tblink = 512ms
5:4	NA	R	NA	Reserved.
3	BAL_1AB2	R	0	1: VLED1 ≥ VLED2 + 130mV 0: VLED1 < VLED2 + 130mV
2	BAL_2AB1	R	0	1: VLED2 ≥ VLED1 + 130mV 0: VLED2 < VLED1 + 130mV
1	FT_LEDHOT	R	0	NTC fault bit. 0 = no fault 1 = fault
0	FT_LEDOP	R	0	LED open fault bit. 0 = no fault 1 = fault

APPLICATION INFORMATION

Selecting the Input Capacitor

The input capacitor reduces the surge current drawn from the input supply and the switching noise from the device. The input capacitor impedance at the switching frequency should be less than the input source impedance to prevent the high-frequency switching current from passing through to the input. Ceramic capacitors with X5R or X7R dielectrics are recommended for their low ESR and small temperature coefficients. A capacitor with a higher value can help reduce input voltage ripple and noise. For most applications, a 10µF ceramic capacitor is sufficient.

Selecting the Inductor

The converter requires an inductor to supply a higher output voltage while being driven by the input voltage. An inductor with a larger value results in less ripple current, a lower peak inductor current, and reduced stress on the internal N-channel MOSFET, but also has a larger physical size, higher series resistance, and lower saturation current.

Choose an inductor that does not saturate under the worst-case load conditions. Select the minimum inductor value to ensure that the boost converter works in continuous conduction mode with high efficiency and good EMI performance.

Calculate the required inductance value using Equation (2) and Equation (3):

$$L \geq \frac{\eta \times V_{OUT} \times D \times (1-D)^2}{2 \times f_{SW} \times I_{LOAD}} \quad (2)$$

$$D = 1 - \frac{V_{IN}}{V_{OUT}} \quad (3)$$

Where V_{IN} and V_{OUT} are the input and output voltages, f_{SW} is the switching frequency, I_{LOAD} is the LED load current, and η is the efficiency.

The switching current is used for peak-current mode control. To avoid hitting the current limit, the worst-case inductor peak current should be less than 80% of the current-limit I_{LIM} . For most applications, 0.47µH~2µH inductor is sufficient.

Selecting the Output Capacitor

The output capacitor keeps the output voltage ripple small and ensures feedback loop stability. The output capacitor impedance must be low at the switching frequency. Ceramic capacitors with X7R dielectrics are recommended for their low ESR characteristics. Ensure that the ceramic capacitance is dependent on the voltage rating. The DC bias voltage and the value can lose as much as 50% of their capacitance at the rated voltage rating. Ensure that enough of a voltage rating margin is left when selecting the component. A capacitance that is too low can cause loop instability. For most applications, a 10µF ceramic capacitor is sufficient.

PCB Layout Guidelines

Efficient PBC layout is critical for stable operation. For best results, follow the guidelines below.

1. Place a ceramic capacitor close to VIN.
2. Use a wider copper wire for input, output, and GND to improve thermal performance.
3. Put as many vias close to GND at the output and input capacitors as possible to improve thermal performance.

PACKAGE INFORMATION

WLCSP20 (1.6mmx2.0mm)

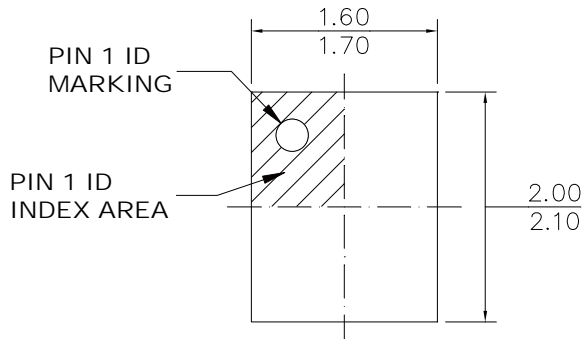

TOP VIEW

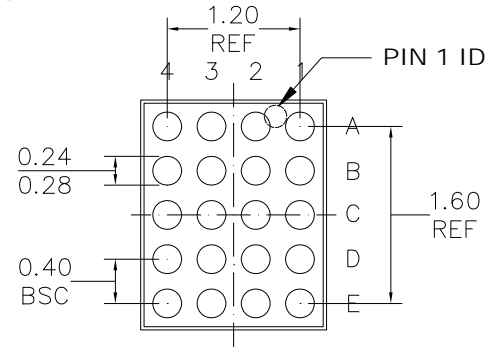

BOTTOM VIEW

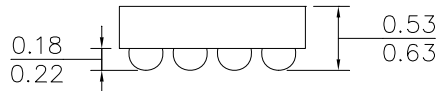

SIDE VIEW

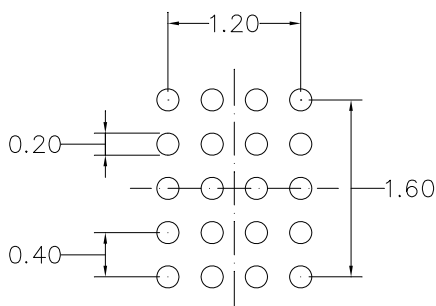

RECOMMENDED LAND PATTERN



NOTE:

- 1) ALL DIMENSIONS ARE IN MILLIMETERS.
- 2) BALL COPLANARITY SHALL BE 0.05 MILLIMETER MAX.
- 3) JEDEC REFERENCE IS MO-211.
- 5) DRAWING IS NOT TO SCALE.

NOTICE: The information in this document is subject to change without notice. Please contact MPS for current specifications. Users should warrant and guarantee that third party Intellectual Property rights are not infringed upon when integrating MPS products into any application. MPS will not assume any legal responsibility for any said applications.

Looking for pricing, stock, or lifecycle information?

Click below to explore more details on WIN SOURCE:

-  [View MP3336GC-P on WIN SOURCE](#)
-  [Monolithic Power Systems Inc. Information](#)

Optimize Your Supply Chain with WIN SOURCE Solutions

-  Global Sourcing Solution
-  Obsolete Management
-  Cost Control Management
-  Shortage Management
-  Alternative Solution
-  Excess Inventory Management