

3.3-V PHASE-LOCK LOOP CLOCK DRIVER WITH 3-STATE OUTPUTS

FEATURES

- Low Output Skew for Clock-Distribution and Clock-Generation Applications
- Operates at 3.3-V V_{CC}
- Distributes One Clock Input to 12 Outputs
- Two Select Inputs Configure Up to Nine Outputs to Operate at One-Half or Double the Input Frequency
- No External RC Network Required
- External Feedback (FBIN) Synchronizes the Outputs to the Clock Input
- Application for Synchronous DRAM, High-Speed Microprocessor
- TTL-Compatible Inputs and Outputs
- Outputs Have Internal 26- Ω Series Resistors to Dampen Transmission-Line Effects
- State-of-the-Art *EPIC-IIB*[™] BiCMOS Design Significantly Reduces Power Dissipation
- Distributed V_{CC} and Ground Pins Reduce Switching Noise
- Packaged in 52-Pin Thin Quad Flat Package

PAH PACKAGE
(TOP VIEW)

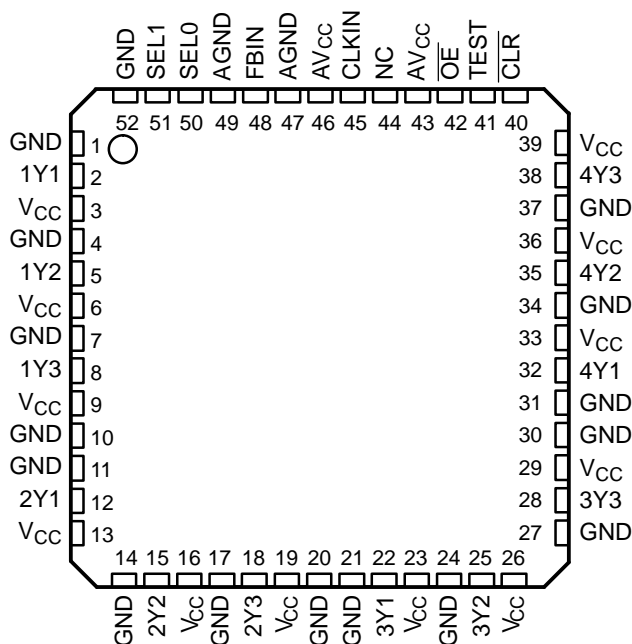

NC – No internal connection

DESCRIPTION

The CDC2586 is a high-performance, low-skew, low-jitter clock driver. It uses a phase-lock loop (PLL) to precisely align, in both frequency and phase, the clock output signals to the clock input (CLKIN) signal. It is specifically designed for use with popular microprocessors operating at speeds from 50 MHz to 100 MHz or down to 25 MHz on outputs configured for half-frequency operation. Each output has an internal 26- Ω series resistor that improves the signal integrity at the load. The CDC2586 operates at nominal 3.3-V V_{CC} .



Please be aware that an important notice concerning availability, standard warranty, and use in critical applications of Texas Instruments semiconductor products and disclaimers thereto appears at the end of this data sheet.

EPIC-IIB is a trademark of Texas Instruments.

The feedback input (FBIN) synchronizes the output clocks in frequency and phase to CLKIN. One of the twelve output clocks must be fed back to FBIN for the PLL to maintain synchronization between CLKIN and the outputs. The output used as feedback is synchronized to the same frequency as CLKIN.

The Y outputs can be configured to switch in phase and at the same frequency as CLKIN. Select inputs (SEL1, SEL0) configure up to nine Y outputs, in banks of three, to operate at one-half or double the CLKIN frequency depending on which output is fed back to FBIN (see Table 1 and Table 2). All output signal duty cycles are adjusted to 50% independent of the duty cycle at CLKIN.

Output-enable (\overline{OE}) provides output control. When \overline{OE} is high, the outputs are in the high-impedance state. When \overline{OE} is low, the outputs are active. TEST is used for factory testing of the device and can be used to bypass the PLL. TEST should be strapped to GND for normal operation.

Unlike many products containing PLLs, the CDC2586 does not require external RC networks. The loop filter for the PLL is included on-chip, minimizing component count, board space, and cost.

Because it is based on PLL circuitry, the CDC2586 requires a stabilization time to achieve phase lock of the feedback signal to the reference signal. This stabilization time is required following power up and application of a fixed-frequency, fixed-phase signal at CLKIN, as well as following any changes to the PLL reference or feedback signals. Such changes occur upon change of the select inputs, enabling of the PLL via TEST, and upon enable of all outputs via \overline{OE} .

The CDC2586 is characterized for operation from 0°C to 70°C.

DETAILED DESCRIPTION OF OUTPUT CONFIGURATIONS

The voltage-controlled oscillator (VCO) used in the CDC2586 PLL has a frequency range of 100 MHz to 200 MHz, twice the operating frequency range of the CDC2586 outputs. The output of the VCO is divided by two and four to provide reference frequencies with a 50% duty cycle of one-half and one-fourth the VCO frequency. The SEL0 and SEL1 inputs select which of the two signals are buffered to each bank of device outputs.

One device output must be externally wired to FBIN to complete the PLL. The VCO operates such that the frequency and phase of this output matches that of the CLKIN signal. In the case that a VCO/2 output is wired to FBIN, the VCO must operate at twice the CLKIN frequency resulting in device outputs that operate at either the same or one-half the CLKIN frequency. If a VCO/4 output is wired to FBIN, the device outputs operate at twice or the same as the CLKIN frequency.

Output Configuration A

Output configuration A is valid when any output configured as a 1x frequency output in Table 1 is fed back to FBIN. The input frequency range for CLKIN is 50 MHz to 100 MHz when using output configuration A. Outputs configured as 1/2 outputs operate at half the CLKIN frequency, while outputs configured as 1x outputs operate at the same frequency as CLKIN.

Table 1. Output Configuration A⁽¹⁾

INPUTS		OUTPUTS	
SEL1	SEL0	1/2× FREQUENCY	1× FREQUENCY
L	L	None	All
L	H	1Yn	2Yn, 3Yn, 4Yn
H	L	1Yn, 2Yn	3Yn, 4Yn
H	H	1Yn, 2Yn, 3Yn	4Yn

(1) n = 1, 2, 3

Output Configuration B

Output configuration B is valid when any output configured as a 1x frequency output in Table 2 is fed back to FBIN. The input frequency range for CLKIN is 25 MHz to 50 MHz when using output configuration B. Outputs configured as 1x outputs operate at the CLKIN frequency, while outputs configured as 2x outputs operate at double the frequency of CLKIN.

Table 2. Output Configuration B⁽¹⁾

INPUTS		OUTPUTS	
SEL1	SEL0	1× FREQUENCY	2× FREQUENCY
L	L	All	None
L	H	1Yn	2Yn, 3Yn, 4Yn
H	L	1Yn, 2Yn	3Yn, 4Yn
H	H	1Yn, 2Yn, 3Yn	4Yn

(1) n = 1, 2, 3

FUNCTIONAL BLOCK DIAGRAM

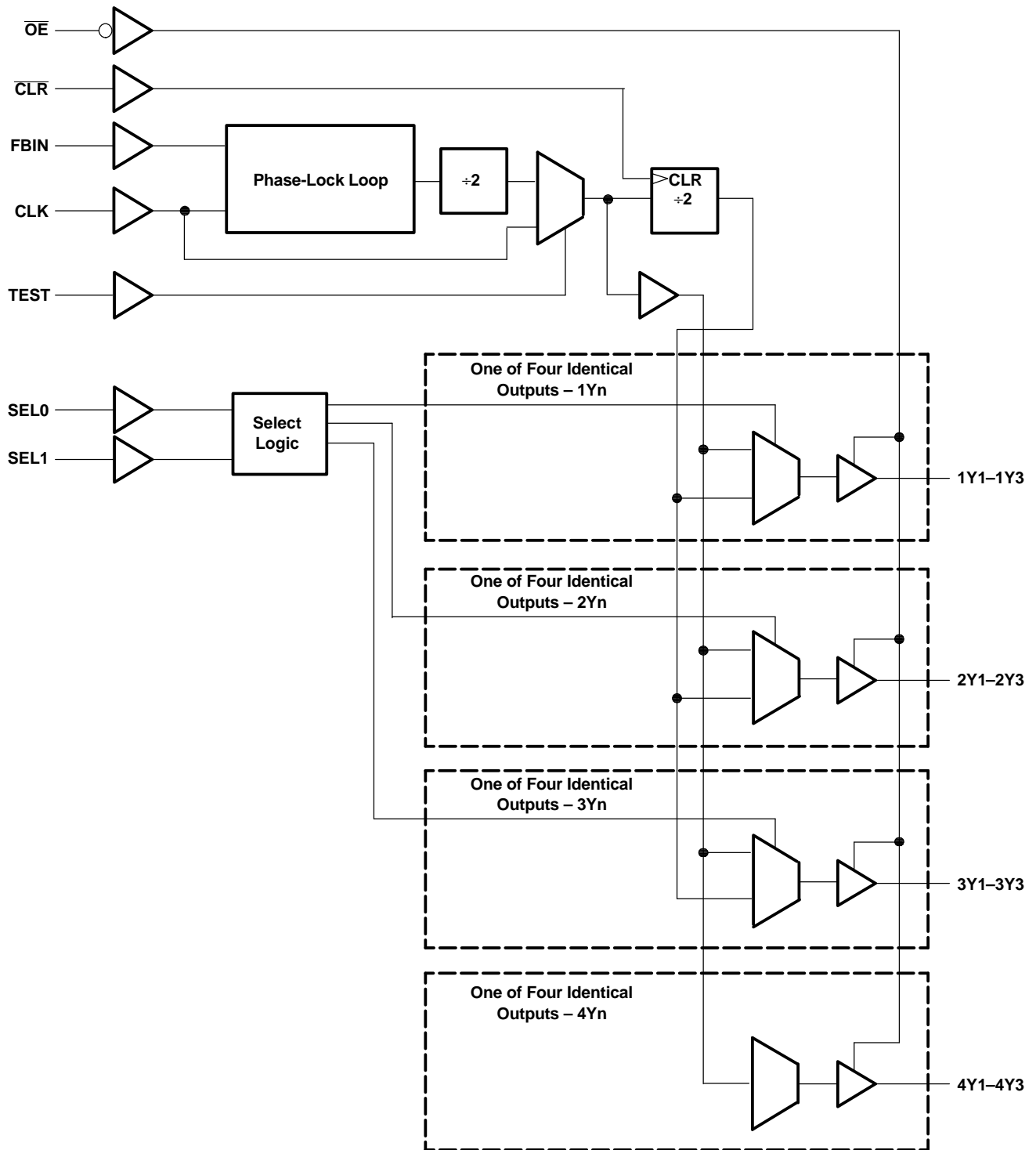

Terminal Functions

TERMINAL NAME	NO.	I/O	DESCRIPTION
CLKIN	45	I	Clock input. CLKIN is the clock signal to be distributed by the CDC2586 clock-driver circuit. CLKIN provides the reference signal to the integrated PLL that generates the clock output signals. CLKIN must have a fixed frequency and fixed phase for the PLL to obtain phase lock. Once the circuit is powered up and a valid CLKIN signal is applied, a stabilization time is required for the PLL to phase lock the feedback signal to its reference signal.
$\overline{\text{CLR}}$	40	I	$\overline{\text{CLR}}$ is used for testing purposes only.
FBIN	48	I	Feedback input. FBIN provides the feedback signal to the internal PLL. FBIN must be hardwired to one of the 12 clock outputs to provide frequency and phase lock. The internal PLL adjusts the output clocks to obtain zero phase delay between FBIN and CLKIN.
$\overline{\text{OE}}$	42	I	Output enable. $\overline{\text{OE}}$ is the output enable for all outputs. When $\overline{\text{OE}}$ is low, all outputs are enabled. When $\overline{\text{OE}}$ is high, all outputs are in the high-impedance state. Since the feedback signal for the PLL is taken directly from an output, placing the outputs in the high-impedance state interrupts the feedback loop; therefore, when a high-to-low transition occurs at $\overline{\text{OE}}$, enabling the output buffers, a stabilization time is required before the PLL obtains phase lock.
SEL1, SEL0	51, 50	I	Output configuration select. SEL0 and SEL1 select the output configuration for each output bank (e.g., 1/2x, 1x, or 2x) (see Table 1 and Table 2).
TEST	41	I	TEST is used to bypass the PLL circuitry for factory testing of the device. When TEST is low, all outputs operate using the PLL circuitry. When TEST is high, the outputs are placed in a test mode that bypasses the PLL circuitry. TEST should be strapped to GND for normal operation.
1Y1-1Y3 2Y1-2Y3 3Y1-3Y3	2, 5, 8 12, 15, 18 22, 25, 28	O	Output ports. These outputs are configured by the select inputs (SEL1, SEL0) to transmit one-half or one-fourth the frequency of the VCO. The relationship between the CLKIN frequency and the output frequency is dependent on the select inputs and the frequency of the output being fed back to FBIN (see Table 1 and Table 2). The duty cycle of the Y output signals is nominally 50%, independent of the duty cycle of CLKIN. Each output has an internal series resistor to dampen transmission-line effects and improve the signal integrity at the load.
4Y1-4Y3	32, 35, 38	O	Output ports. 4Y1-4Y3 transmit one-half the frequency of the VCO regardless of the state of the select inputs. The relationship between the CLKIN frequency and the output frequency is dependent on the frequency of the output being fed back to FBIN (see Table 1 and Table 2). The duty cycle of the Y output signals is nominally 50%, independent of the duty cycle of CLKIN. Each output has an internal series resistor to dampen transmission-line effects and improve the signal integrity at the load.

ABSOLUTE MAXIMUM RATINGS

over operating free-air temperature range (unless otherwise noted) ⁽¹⁾

	UNIT
Supply voltage range, V_{CC}	-0.5 V to 4.6 V
Input voltage range, V_I ⁽²⁾	-0.5 V to 7 V
Voltage range applied to any output in the high state or power-off state, V_O ⁽²⁾	-0.5 V to 5.5 V
Current into any output in the low state, I_O	24 mA
Input clamp current, $I_{IK}(V_I < 0)$	-20 mA
Output clamp current, $I_{OK}(V_O < 0)$	-50 mA
Maximum power dissipation at $T_A = 55^\circ\text{C}$ (in still air) ⁽³⁾	1.2 W
Storage temperature range, T_{stg}	-65°C to 150°C

- (1) Stresses beyond those listed under "absolute maximum ratings" may cause permanent damage to the device. These are stress ratings only, and functional operation of the device at these or any other conditions beyond those indicated under "recommended operating conditions" is not implied. Exposure to absolute-maximum-rated conditions for extended periods may affect device reliability.
- (2) The input and output negative-voltage ratings may be exceeded if the input and output clamp-current ratings are observed.
- (3) The maximum package power dissipation is calculated using a junction temperature of 150°C and a board trace length of 75 mils. For more information, see the *Package Thermal Considerations* application note in the *ABT Advanced BiCMOS Technology Data Book*, literature number SCBD002.

RECOMMENDED OPERATING CONDITIONS ⁽¹⁾

		MIN	MAX	UNIT
V _{CC}	Supply voltage	3	3.6	V
V _{IH}	High-level input voltage	2		V
V _{IL}	Low-level input voltage		0.8	V
V _I	Input voltage	0	5.5	V
I _{OH}	High-level output current		-12	mA
I _{OL}	Low-level output current		12	mA
T _A	Operating free-air temperature	0	70	°C

(1) Unused inputs must be held high or low to prevent them from floating.

ELECTRICAL CHARACTERISTICS

over recommended operating free-air temperature range (unless otherwise noted)

PARAMETER	TEST CONDITIONS	T _A = 25°C		UNIT
		MIN	MAX	
V _{IK}	V _{CC} = 3 V, I _I = -18 mA		-1.2	V
V _{OH}	V _{CC} = MIN to MAX ⁽¹⁾ , I _{OH} = -100 μA	V _{CC} -0.2		V
	V _{CC} = 3 V, I _{OH} = -12 mA	2		
V _{OL}	V _{CC} = 3 V	I _{OL} = 100 μA	0.2	V
		I _{OL} = 12 mA	0.8	
I _I	V _{CC} = 0, V _I = 3.6 V	±10		μA
	V _{CC} = 3.6 V, V _I = V _{CC} or GND	±1		
I _{OZH}	V _{CC} = 3.6 V, V _O = 3 V	10		μA
I _{OZL}	V _{CC} = 3.6 V, V _O = 0	-10		μA
I _{CC}	V _{CC} = 3.6 V, I _O = 0, V _I = V _{CC} or GND	Outputs high	1	mA
		Outputs low	1	
		Outputs disabled	1	
C _i	V _I = V _{CC} or GND	4		pF
C _o	V _O = V _{CC} or GND	8		pF

(1) For conditions shown as MIN or MAX, use the appropriate value specified under recommended operating conditions.

TIMING REQUIREMENTS

over recommended ranges of supply voltage and operating free-air temperature

		MIN	MAX	UNIT	
f _{clock}	Clock frequency	VCO operating at four times the CLKIN frequency	25	50	MHz
		VCO operating at double the CLKIN frequency	50	100	
Input clock duty cycle		40%	60%		
Stabilization time ⁽¹⁾	After SEL1, SEL0	50		μs	
	After \overline{OE} ↓	50			
	After power up	50			
	After CLKIN	50			

(1) Time required for the integrated PLL circuit to obtain phase lock of its feedback signal to its reference signal. In order for phase lock to be obtained, a fixed-frequency, fixed-phase reference signal must be present at CLKIN. Until phase lock is obtained, the specifications for propagation delay and skew parameters given in the *switching characteristic* table are not applicable.

SWITCHING CHARACTERISTICS

over recommended ranges of supply voltage and operating free-air temperature, $C_L = 15$ pF (see ⁽¹⁾ and Figure 1 through Figure 3)

PARAMETER	FROM (INPUT)	TO (OUTPUT)	MIN	MAX	UNIT
f_{max}				100	MHz
Duty cycle		Y	45%	55%	
$t_{phase\ error}^{(2)}$	CLKIN↑	Y↑	-500	+500	ps
jitter	CLKIN↑	Y↑		200	ps
$t_{sk(o)}^{(2)}$				0.5	ns
$t_{sk(pr)}^{(2)}$				1	ns
t_r				1.4	ns
t_f				1.4	ns

- (1) The specifications for parameters in this table are applicable only after any appropriate stabilization time has elapsed.
 (2) The propagation delay, $t_{phase\ error}$, is dependent on the feedback path from any output to FBIN. The $t_{phase\ error}$, $t_{sk(o)}$, and $t_{sk(pr)}$ specifications are valid only for equal loading of all outputs.

PARAMETER MEASUREMENT INFORMATION

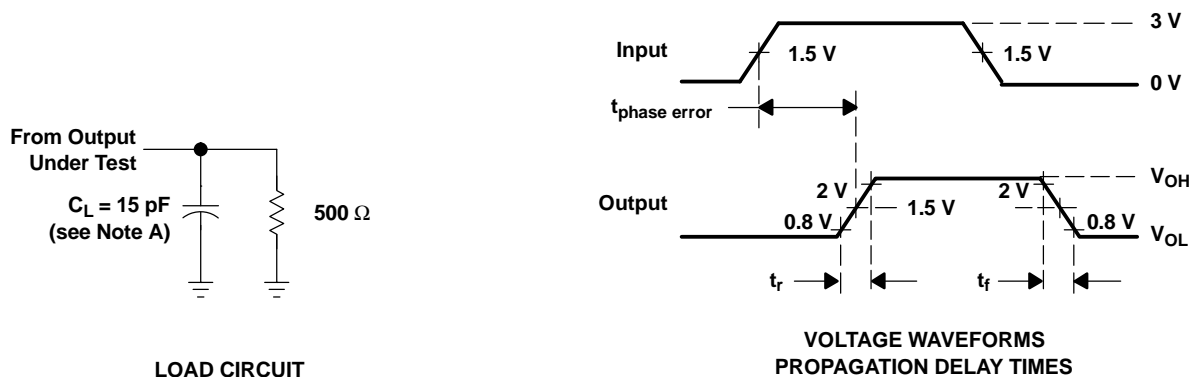

- A. C_L includes probe and jig capacitance.
 B. All input pulses are supplied by generators having the following characteristics: $PRR \leq 100$ MHz, $Z_O = 50$ Ω , $t_r \leq 2.5$ ns, $t_f \leq 2.5$ ns.
 C. The outputs are measured one at a time with one transition per measurement.

Figure 1. Load Circuit and Voltage Waveforms

PARAMETER MEASUREMENT INFORMATION (continued)

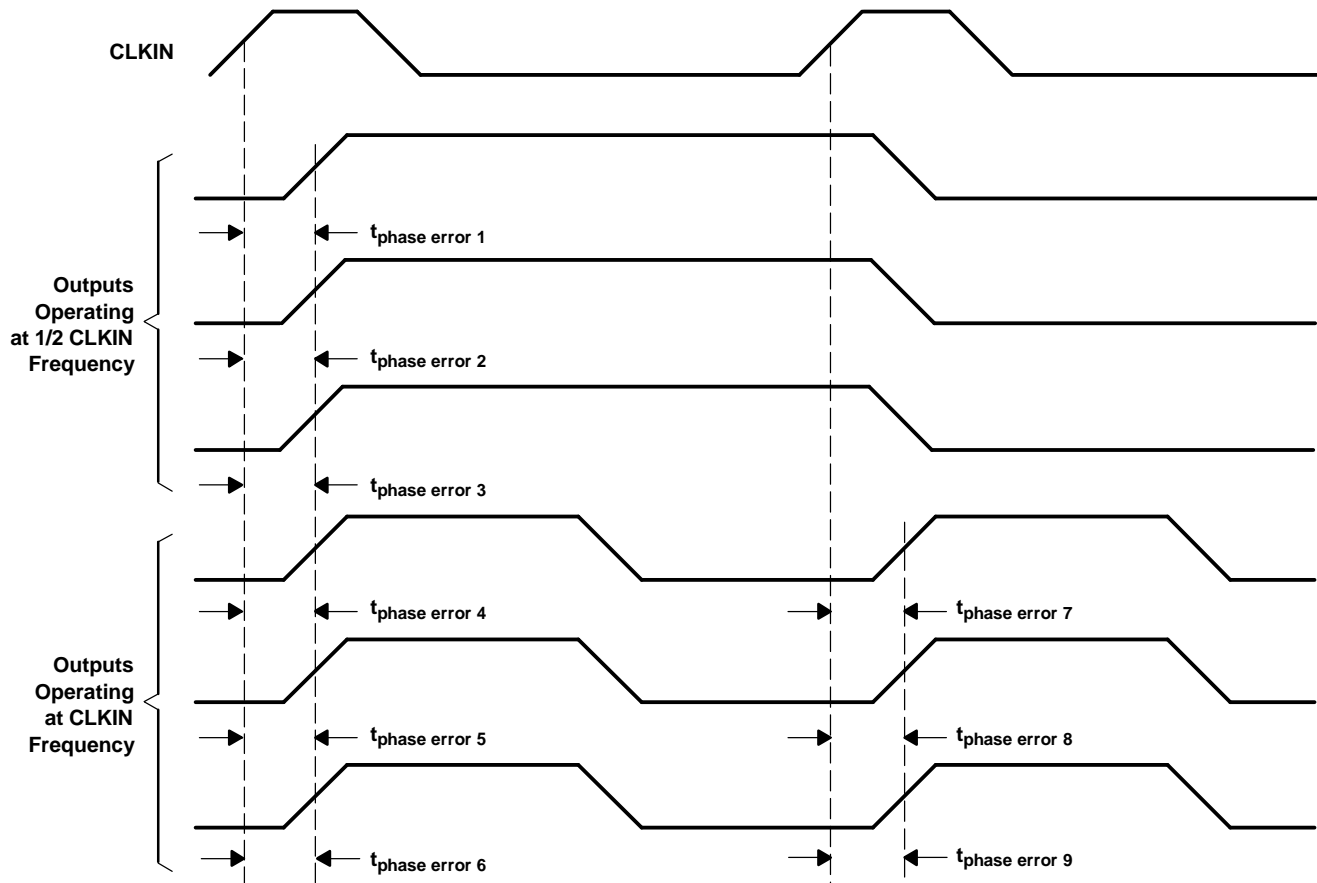

- A. Output skew, $t_{sk(o)}$, is calculated as the greater of:
 - The difference between the fastest and slowest of $t_{phase\ error\ n}$ ($n = 1, 2, \dots 6$)
 - The difference between the fastest and slowest of $t_{phase\ error\ n}$ ($n = 7, 8, 9$)
- B. Process skew, $t_{sk(pr)}$, is calculated as the greater of:
 - The difference between the maximum and minimum $t_{phase\ error\ n}$ ($n = 1, 2, \dots 6$) across multiple devices under identical operating conditions
 - The difference between the maximum and minimum $t_{phase\ error\ n}$ ($n = 7, 8, 9$) across multiple devices under identical operating conditions
- C. For configuration A, see Table 1

Figure 2. Waveforms for Calculation of $t_{sk(o)}$ for Configuration A

PARAMETER MEASUREMENT INFORMATION (continued)

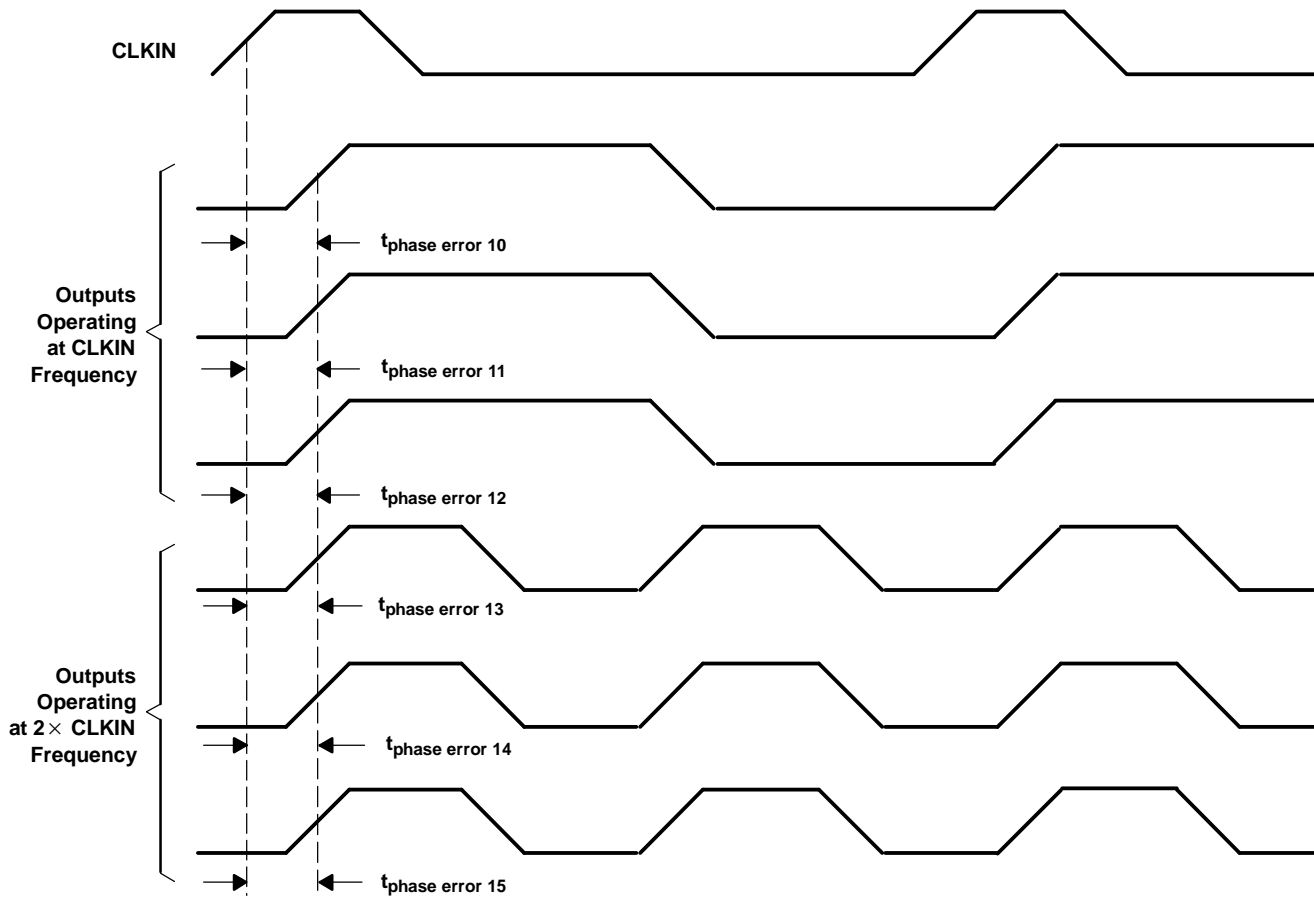

- A. Output skew, $t_{sk(o)}$, is calculated as the greater of:
 - The difference between the fastest and slowest of $t_{\text{phase error } n}$ ($n = 10, 11, \dots, 15$)
- B. Process skew, $t_{sk(pr)}$, is calculated as the greater of:
 - The difference between the maximum and minimum $t_{\text{phase error } n}$ ($n = 10, 11, \dots, 15$) across multiple devices under identical operating conditions
- C. For configuration B, see Table 2

Figure 3. Waveforms for Calculation of $t_{sk(o)}$ for Configuration B

PACKAGING INFORMATION

Orderable Device	Status ⁽¹⁾	Package Type	Package Drawing	Pins	Package Qty	Eco Plan ⁽²⁾	Lead/Ball Finish	MSL Peak Temp ⁽³⁾
CDC2586PAH	ACTIVE	TQFP	PAH	52	160	Green (RoHS & no Sb/Br)	CU NIPDAU	Level-4-260C-72 HR
CDC2586PAHG4	ACTIVE	TQFP	PAH	52	160	Green (RoHS & no Sb/Br)	CU NIPDAU	Level-4-260C-72 HR
CDC2586PAHR	ACTIVE	TQFP	PAH	52	1500	Green (RoHS & no Sb/Br)	CU NIPDAU	Level-4-260C-72 HR
CDC2586PAHRG4	ACTIVE	TQFP	PAH	52	1500	Green (RoHS & no Sb/Br)	CU NIPDAU	Level-4-260C-72 HR

⁽¹⁾ The marketing status values are defined as follows:

ACTIVE: Product device recommended for new designs.

LIFEBUY: TI has announced that the device will be discontinued, and a lifetime-buy period is in effect.

NRND: Not recommended for new designs. Device is in production to support existing customers, but TI does not recommend using this part in a new design.

PREVIEW: Device has been announced but is not in production. Samples may or may not be available.

OBSOLETE: TI has discontinued the production of the device.

⁽²⁾ Eco Plan - The planned eco-friendly classification: Pb-Free (RoHS), Pb-Free (RoHS Exempt), or Green (RoHS & no Sb/Br) - please check <http://www.ti.com/productcontent> for the latest availability information and additional product content details.

TBD: The Pb-Free/Green conversion plan has not been defined.

Pb-Free (RoHS): TI's terms "Lead-Free" or "Pb-Free" mean semiconductor products that are compatible with the current RoHS requirements for all 6 substances, including the requirement that lead not exceed 0.1% by weight in homogeneous materials. Where designed to be soldered at high temperatures, TI Pb-Free products are suitable for use in specified lead-free processes.

Pb-Free (RoHS Exempt): This component has a RoHS exemption for either 1) lead-based flip-chip solder bumps used between the die and package, or 2) lead-based die adhesive used between the die and leadframe. The component is otherwise considered Pb-Free (RoHS compatible) as defined above.

Green (RoHS & no Sb/Br): TI defines "Green" to mean Pb-Free (RoHS compatible), and free of Bromine (Br) and Antimony (Sb) based flame retardants (Br or Sb do not exceed 0.1% by weight in homogeneous material)

⁽³⁾ MSL, Peak Temp. -- The Moisture Sensitivity Level rating according to the JEDEC industry standard classifications, and peak solder temperature.

Important Information and Disclaimer:The information provided on this page represents TI's knowledge and belief as of the date that it is provided. TI bases its knowledge and belief on information provided by third parties, and makes no representation or warranty as to the accuracy of such information. Efforts are underway to better integrate information from third parties. TI has taken and continues to take reasonable steps to provide representative and accurate information but may not have conducted destructive testing or chemical analysis on incoming materials and chemicals. TI and TI suppliers consider certain information to be proprietary, and thus CAS numbers and other limited information may not be available for release.

In no event shall TI's liability arising out of such information exceed the total purchase price of the TI part(s) at issue in this document sold by TI to Customer on an annual basis.

TAPE AND REEL INFORMATION



QUADRANT ASSIGNMENTS FOR PIN 1 ORIENTATION IN TAPE

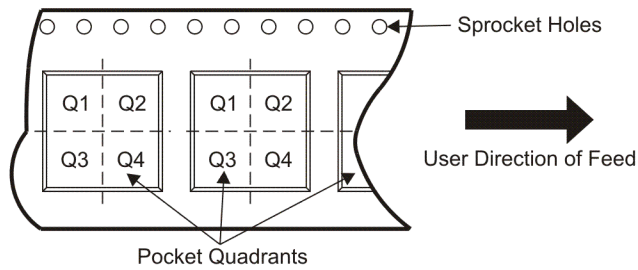

*All dimensions are nominal

Device	Package Type	Package Drawing	Pins	SPQ	Reel Diameter (mm)	Reel Width W1 (mm)	A0 (mm)	B0 (mm)	K0 (mm)	P1 (mm)	W (mm)	Pin1 Quadrant
CDC2586PAHR	TQFP	PAH	52	1500	330.0	24.4	13.0	13.0	1.5	16.0	24.0	Q2

TAPE AND REEL BOX DIMENSIONS



*All dimensions are nominal

Device	Package Type	Package Drawing	Pins	SPQ	Length (mm)	Width (mm)	Height (mm)
CDC2586PAHR	TQFP	PAH	52	1500	346.0	346.0	41.0

PAH (S-PQFP-G52)

PLASTIC QUAD FLATPACK

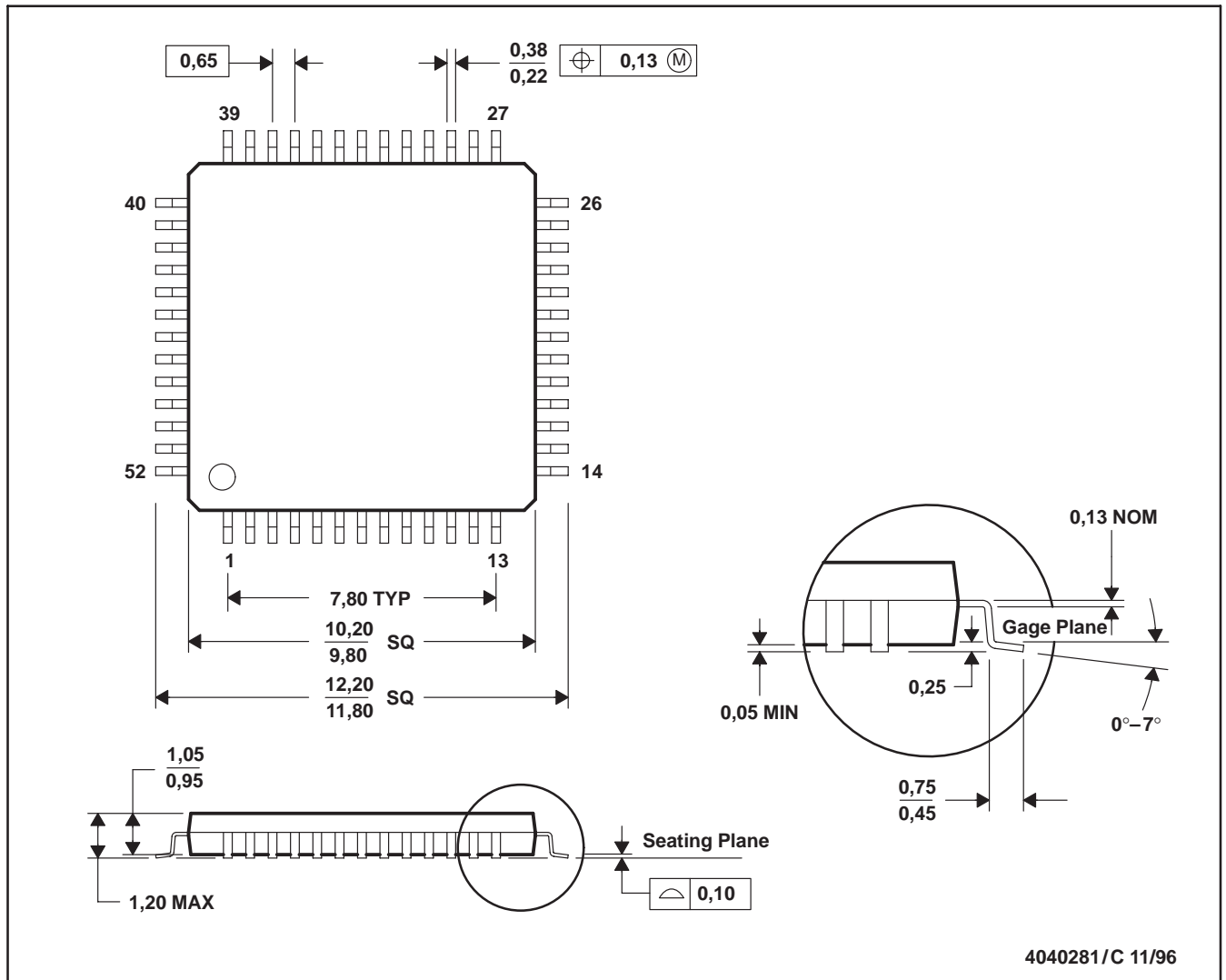

- NOTES: A. All linear dimensions are in millimeters.
 B. This drawing is subject to change without notice.
 C. Falls within JEDEC MS-026

IMPORTANT NOTICE

Texas Instruments Incorporated and its subsidiaries (TI) reserve the right to make corrections, modifications, enhancements, improvements, and other changes to its products and services at any time and to discontinue any product or service without notice. Customers should obtain the latest relevant information before placing orders and should verify that such information is current and complete. All products are sold subject to TI's terms and conditions of sale supplied at the time of order acknowledgment.

TI warrants performance of its hardware products to the specifications applicable at the time of sale in accordance with TI's standard warranty. Testing and other quality control techniques are used to the extent TI deems necessary to support this warranty. Except where mandated by government requirements, testing of all parameters of each product is not necessarily performed.

TI assumes no liability for applications assistance or customer product design. Customers are responsible for their products and applications using TI components. To minimize the risks associated with customer products and applications, customers should provide adequate design and operating safeguards.

TI does not warrant or represent that any license, either express or implied, is granted under any TI patent right, copyright, mask work right, or other TI intellectual property right relating to any combination, machine, or process in which TI products or services are used. Information published by TI regarding third-party products or services does not constitute a license from TI to use such products or services or a warranty or endorsement thereof. Use of such information may require a license from a third party under the patents or other intellectual property of the third party, or a license from TI under the patents or other intellectual property of TI.

Reproduction of TI information in TI data books or data sheets is permissible only if reproduction is without alteration and is accompanied by all associated warranties, conditions, limitations, and notices. Reproduction of this information with alteration is an unfair and deceptive business practice. TI is not responsible or liable for such altered documentation. Information of third parties may be subject to additional restrictions.

Resale of TI products or services with statements different from or beyond the parameters stated by TI for that product or service voids all express and any implied warranties for the associated TI product or service and is an unfair and deceptive business practice. TI is not responsible or liable for any such statements.

TI products are not authorized for use in safety-critical applications (such as life support) where a failure of the TI product would reasonably be expected to cause severe personal injury or death, unless officers of the parties have executed an agreement specifically governing such use. Buyers represent that they have all necessary expertise in the safety and regulatory ramifications of their applications, and acknowledge and agree that they are solely responsible for all legal, regulatory and safety-related requirements concerning their products and any use of TI products in such safety-critical applications, notwithstanding any applications-related information or support that may be provided by TI. Further, Buyers must fully indemnify TI and its representatives against any damages arising out of the use of TI products in such safety-critical applications.

TI products are neither designed nor intended for use in military/aerospace applications or environments unless the TI products are specifically designated by TI as military-grade or "enhanced plastic." Only products designated by TI as military-grade meet military specifications. Buyers acknowledge and agree that any such use of TI products which TI has not designated as military-grade is solely at the Buyer's risk, and that they are solely responsible for compliance with all legal and regulatory requirements in connection with such use.

TI products are neither designed nor intended for use in automotive applications or environments unless the specific TI products are designated by TI as compliant with ISO/TS 16949 requirements. Buyers acknowledge and agree that, if they use any non-designated products in automotive applications, TI will not be responsible for any failure to meet such requirements.

Following are URLs where you can obtain information on other Texas Instruments products and application solutions:

Products

Amplifiers	amplifier.ti.com
Data Converters	dataconverter.ti.com
DSP	dsp.ti.com
Clocks and Timers	www.ti.com/clocks
Interface	interface.ti.com
Logic	logic.ti.com
Power Mgmt	power.ti.com
Microcontrollers	microcontroller.ti.com
RFID	www.ti-rfid.com
RF/IF and ZigBee® Solutions	www.ti.com/lprf

Applications

Audio	www.ti.com/audio
Automotive	www.ti.com/automotive
Broadband	www.ti.com/broadband
Digital Control	www.ti.com/digitalcontrol
Medical	www.ti.com/medical
Military	www.ti.com/military
Optical Networking	www.ti.com/opticalnetwork
Security	www.ti.com/security
Telephony	www.ti.com/telephony
Video & Imaging	www.ti.com/video
Wireless	www.ti.com/wireless

Mailing Address: Texas Instruments, Post Office Box 655303, Dallas, Texas 75265
Copyright © 2008, Texas Instruments Incorporated

Looking for pricing, stock, or lifecycle information?

Click below to explore more details on WIN SOURCE:

 [View CDC2586PAHRG4](#) on WIN SOURCE

 [Texas Instruments](#) Information

Optimize Your Supply Chain with WIN SOURCE Solutions

-  Global Sourcing Solution
-  Obsolete Management
-  Cost Control Management
-  Shortage Management
-  Alternative Solution
-  Excess Inventory Management