



**THE DATASHEET OF
HCMP06C12-M20**



THIS COPY IS PROVIDED ON A RESTRICTED BASIS AND IS NOT TO BE USED IN ANY WAY DETRIMENTAL TO THE INTERESTS OF PANDUIT CORP.

PANDUIT PART NO.	BUNDLE DIA MIN - MAX.	DIMENSIONS					MATERIAL	COLOR	WEIGHT grams 100 pcs
		'A'	'B'		'D'	'E'			
HCMP06C12-...30	6 - 12	20.2	15.7		10	27.9	NYLON 6/6 HEAT STABILIZED	BLACK	160
HCMP06C12-...20							NYLON 6/6		

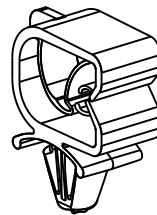
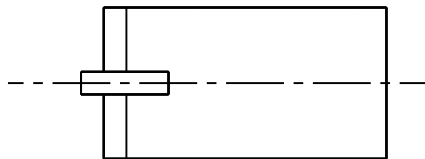
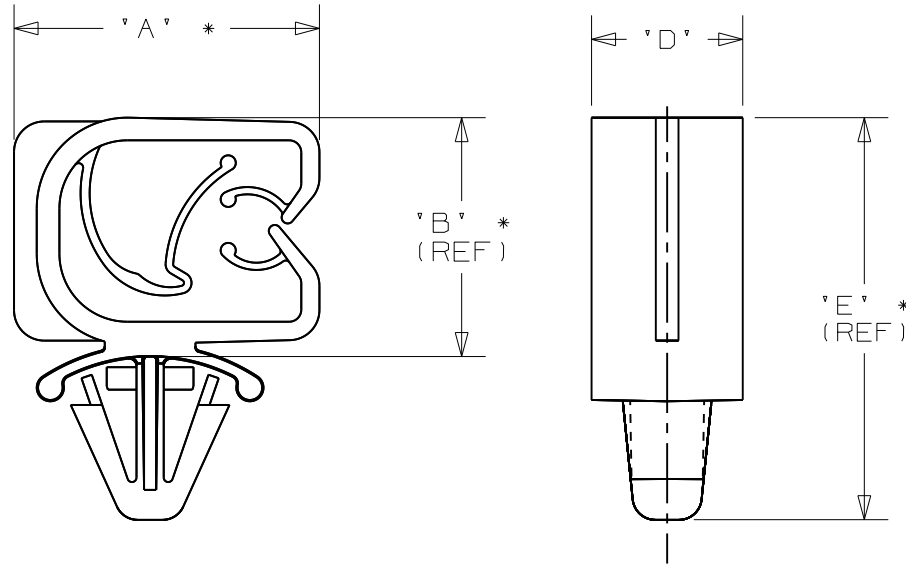

SCALE: FULL

NOTES:

1. SEE CURRENT PRICE SHEET FOR PART NUMBER SUFFIX DESIGNATION FOR PACKAGE SIZE, AND COLOR.
2. (*) DIMENSIONAL VARIANCE IS POSSIBLE DUE TO MOLDING PROCESS RELATED SINK MARKS.
3. APPLICATION SPECIFICATION:
 HOLE DIAMETER: 6.3 - 7.2 mm
 PANEL THICKNESS: 0.6 - 3.0 mm

CAD FILENAME/LAYERS		G01932BC_PB_HCMP06C12_05	
PANDUIT CORP.		TINLEY PARK, ILLINOIS	
HARNESS CLIP WITH PUSH MOUNT ANCHOR			
Unless otherwise specified, all dimensions are metric tolerance; ±0.5mm			
DRAWN BY	JAD	MAT'L:	SCALE 2x
DATE	5-04-98	SEE TABLE	DRAWING NO.
CHK'D			GB1932BC

5	4/29/03	JAD		COMPLETELY REVISED, REMOVED GERMAN TEXT	GB1932BC	5			
REV	DATE	BY	CHK	DESCRIPTION	ECN	R	CUST	SUP	

Looking for pricing, stock, or lifecycle information?

Click below to explore more details on WIN SOURCE:

 [View HCMP06C12-M20 on WIN SOURCE](#)

 [Panduit Corp Information](#)

Optimize Your Supply Chain with WIN SOURCE Solutions

-  Global Sourcing Solution
-  Obsolete Management
-  Cost Control Management
-  Shortage Management
-  Alternative Solution
-  Excess Inventory Management