



THE DATASHEET OF CDCE937PW



CDCE937 Flexible Low Power LVCMOS Clock Generator With SSC Support For EMI Reduction

1 Features

- Member of Programmable Clock Generator Family
 - CDCE913: 1-PLL, 3 Outputs
 - CDCE925: 2-PLL, 5 Outputs
 - *CDCE937: 3-PLL, 7 Outputs*
 - CDCE949: 4-PLL, 9 Outputs
- In-System Programmability and EEPROM
 - Serial Programmable Volatile Register
 - Nonvolatile EEPROM to Store Customer Setting
- Flexible Input Clocking Concept
 - External Crystal: 8 MHz to 32 MHz
 - On-Chip VCXO: Pull Range ± 150 ppm
 - Single-Ended LVCMOS up to 160 MHz
- Free Selectable Output Frequency up to 230 MHz
- Low-Noise PLL Core
 - PLL Loop Filter Components Integrated
 - Low Period Jitter (Typical 60 ps)
- Separate Output Supply Pins
 - CDCE937: 3.3 V and 2.5 V
 - CDCEL937: 1.8 V
- Flexible Clock Driver
 - Three User-Definable Control Inputs [S0/S1/S2], for Example, SSC Selection, Frequency Switching, Output Enable or Power Down
 - Generates Highly Accurate Clocks for Video, Audio, USB, IEEE1394, RFID, Bluetooth™, WLAN, Ethernet™, and GPS
 - Generates Common Clock Frequencies Used With TI-DaVinci™, OMAP™, DSPs
 - Programmable SSC Modulation
 - Enables 0-PPM Clock Generation
- 1.8-V Device Power Supply
- Wide Temperature Range -40°C to 85°C
- Packaged in TSSOP
- Development and Programming Kit for Easy PLL Design and Programming (TI Pro-Clock™)

2 Applications

D-TVs, STBs, IP-STBs, DVD Players, DVD Recorders, and Printers

3 Description

The CDCE937 and CDCEL937 devices are modular PLL-based low cost, high-performance, programmable clock synthesizers, multipliers and dividers. They generate up to 7 output clocks from a single input frequency. Each output can be programmed in-system for any clock frequency up to 230 MHz, using up to three independent configurable PLLs.

The CDCE937 has separate output supply pins, VDDOUT, which is 1.8 V for CDCEL937 and to 2.5 V to 3.3 V for CDCE937.

The input accepts an external crystal or LVCMOS clock signal. If an external crystal is used, an on-chip load capacitor is adequate for most applications. The value of the load capacitor is programmable from 0 to 20 pF. Additionally, an on-chip VCXO is selectable which allows synchronization of the output frequency to an external control signal, that is, PWM signal.

Device Information⁽¹⁾

PART NUMBER	PACKAGE	BODY SIZE (NOM)
CDCE937, CDCEL937	TSSOP (20)	6.50 mm x 4.40 mm

(1) For all available packages, see the orderable addendum at the end of the datasheet.

Typical Application Schematic

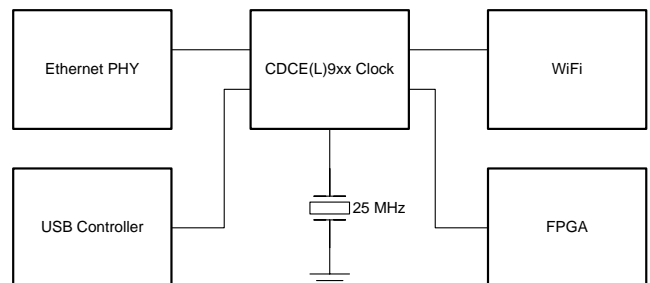

Copyright © 2016, Texas Instruments Incorporated



Table of Contents

1 Features	1	8.4 Device Functional Modes	15
2 Applications	1	8.5 Programming	16
3 Description	1	8.6 Register Maps	17
4 Revision History	2	9 Application and Implementation	24
5 Pin Configuration and Functions	4	9.1 Application Information	24
6 Specifications	5	9.2 Typical Application	24
6.1 Absolute Maximum Ratings	5	10 Power Supply Recommendations	29
6.2 ESD Ratings	5	11 Layout	29
6.3 Recommended Operating Conditions	5	11.1 Layout Guidelines	29
6.4 Thermal Information	6	11.2 Layout Example	30
6.5 Electrical Characteristics	6	12 Device and Documentation Support	31
6.6 Timing Requirements: CLK_IN	8	12.1 Device Support	31
6.7 Timing Requirements: SDA/SCL	8	12.2 Documentation Support	31
6.8 EEPROM Specification	8	12.3 Receiving Notification of Documentation Updates	31
6.9 Typical Characteristics	9	12.4 Community Resources	31
7 Parameter Measurement Information	10	12.5 Trademarks	31
8 Detailed Description	11	12.6 Electrostatic Discharge Caution	31
8.1 Overview	11	12.7 Glossary	31
8.2 Functional Block Diagram	12	13 Mechanical, Packaging, and Orderable Information	32
8.3 Feature Description	12		

4 Revision History

NOTE: Page numbers for previous revisions may differ from page numbers in the current version.

Changes from Revision F (March 2010) to Revision G	Page
• Added ESD Ratings table, Feature Description section, Device Functional Modes, Application and Implementation section, Power Supply Recommendations section, Layout section, Device and Documentation Support section, and Mechanical, Packaging, and Orderable Information section	1
• Changed Applications	1
• Changed Thermal Resistance Junction to Ambient, $R_{\theta JA}$, values in Thermal Information From: 89 (0 lfm), 75 (150 lfm), 74 (200 lfm), 74 (250 lfm), and 69 (500 lfm) To: 89.04	6
• Deleted Input Capacitance figure	19

Changes from Revision E (October 2009) to Revision F	Page
• Added PLL settings limits: $16 \leq q \leq 63$, $0 \leq p \leq 7$, $0 \leq r \leq 511$, $0 < N < 4096$ foot to PLL1, PLL2, and PLL3 Configure Register Table	20
• Changed $100 \text{ MHz} < f_{VCO} > 200 \text{ MHz}$; $TO \ 80 \text{ MHz} \leq f_{VCO} \leq 230 \text{ MHz}$; and changed $0 \leq p \leq 7$ TO $0 \leq p \leq 4$	26
• Changed under Example, fifth row, N", 2 places TO N'	26

Changes from Revision D (September 2009) to Revision E	Page
• Deleted sentence - A different default setting can be programmed on customer request. Contact Texas Instruments sales or marketing representative for more information.	14

Changes from Revision C (January 2009) to Revision D	Page
• Added Note 3: SDA and SCL can go up to 3.6 V as stated in the Recommended Operating Conditions table	5

Changes from Revision B (December 2007) to Revision C **Page**

- Changed *Generic Configuration Register* table SLAVE_ADR default value From: 00b To: 01b [18](#)
-

Changes from Revision A (September 2007) to Revision B **Page**

- Changed Terminal Functions Table - the pin numbers to correspond with pin outs on the package [4](#)
 - Changed *Generic Configuration Register* table RID default From: 0h To: Xb [18](#)
 - Added note to PWDN description to *Generic Configuration Register* table [18](#)
-

Changes from Original (August 2007) to Revision A **Page**

- Changed the data sheet status From: Product Preview To: Production data [1](#)
-

5 Pin Configuration and Functions

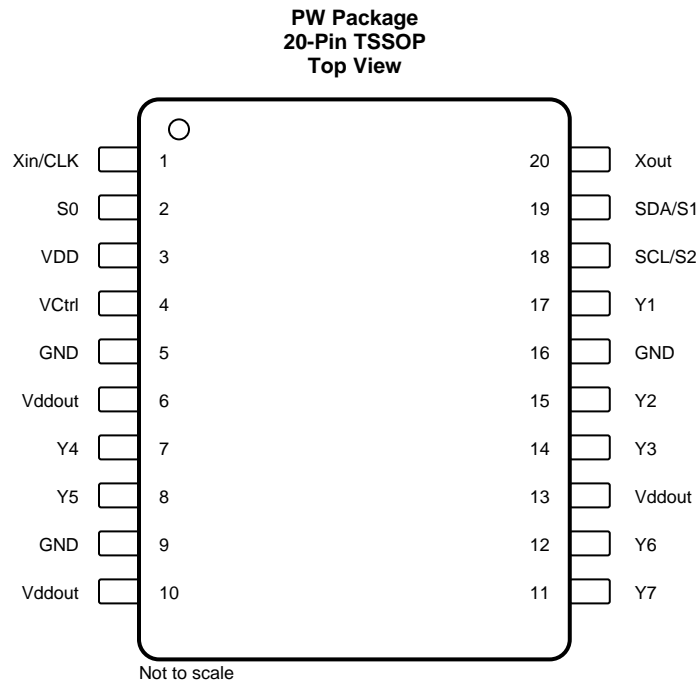

Pin Functions

PIN		TYPE ⁽¹⁾	DESCRIPTION
NAME	NO.		
GND	5, 9, 16	G	Ground
SCL/S2	18	I	SCL: Serial clock input (default configuration), LVCMOS; Internal pullup 500k; S2: User programmable control input; LVCMOS inputs; Internal pullup 500k
SDA/S1	19	I/O	SDA: Bi-directional serial data input/output (default configuration). LVCMOS; Internal pullup 500k; S1: User programmable control input; LVCMOS inputs; Internal pullup 500k
S0	2	I	User programmable control input S0; LVCMOS inputs; Internal pullup 500k
V _{Ctrl}	4	I	VCXO control voltage, leave open or pullup (approximately 500k) when not used
V _{DD}	3	P	1.8-V power supply for the device
Vddout	6, 10, 13	P	CDCEL937: 1.8-V supply for all outputs CDCE937: 3.3-V or 2.5-V supply for all outputs
Xin/CLK	1	I	Crystal oscillator input or LVCMOS clock input (selectable through SDA/SCL bus)
Xout	20	O	Crystal oscillator output, leave open or pullup (~500k) when not used
Y1	17	O	LVCMOS outputs
Y2	15	O	LVCMOS outputs
Y3	14	O	LVCMOS outputs
Y4	7	O	LVCMOS outputs
Y5	8	O	LVCMOS outputs
Y6	12	O	LVCMOS outputs
Y7	11	O	LVCMOS outputs

(1) G= Ground, I = Input, O = Output, P = Power

6 Specifications

6.1 Absolute Maximum Ratings

over operating free-air temperature range (unless otherwise noted)⁽¹⁾

	MIN	MAX	UNIT
Supply voltage, V_{DD}	-0.5	2.5	V
Input voltage, V_I ⁽²⁾⁽³⁾	-0.5	$V_{DD} + 0.5$	V
Output voltage, V_O ⁽²⁾	-0.5	$V_{DDout} + 0.5$	V
Input current, I_I ($V_I < 0$, $V_I > V_{DD}$)		20	mA
Continuous output current, I_O		50	mA
Junction temperature, T_J		125	°C
Storage temperature, T_{stg}	-65	150	°C

- (1) Stresses beyond those listed under *Absolute Maximum Ratings* may cause permanent damage to the device. These are stress ratings only, which do not imply functional operation of the device at these or any other conditions beyond those indicated under *Recommended Operating Conditions*. Exposure to absolute-maximum-rated conditions for extended periods may affect device reliability.
- (2) The input and output negative voltage ratings may be exceeded if the input and output clamp-current ratings are observed.
- (3) SDA and SCL can go up to 3.6 V as stated in [Recommended Operating Conditions](#).

6.2 ESD Ratings

		VALUE	UNIT
$V_{(ESD)}$ Electrostatic discharge	Human-body model (HBM), per ANSI/ESDA/JEDEC JS-001 ⁽¹⁾	±2000	V
	Charged-device model (CDM), per JEDEC specification JESD22-C101 ⁽²⁾	±1500	

- (1) JEDEC document JEP155 states that 500-V HBM allows safe manufacturing with a standard ESD control process.
- (2) JEDEC document JEP157 states that 250-V CDM allows safe manufacturing with a standard ESD control process.

6.3 Recommended Operating Conditions

		MIN	NOM	MAX	UNIT
V_{DD}	Device supply voltage	1.7	1.8	1.9	V
V_O	Output Yx supply voltage, V_{DDout}	CDCE937		3.6	V
		CDCEL937	1.7	1.9	
V_{IL}	Low-level input voltage LVCMOS			$0.3 \times V_{DD}$	V
V_{IH}	High-level input voltage LVCMOS	$0.7 \times V_{DD}$			V
$V_{I(thresh)}$	Input voltage threshold LVCMOS		$0.5 \times V_{DD}$		V
V_{IS}	Input voltage	S0	0	1.9	V
		S1, S2, SDA, SCL, $V_{I(thresh)} = 0.5 V_{DD}$	0	3.6	
$V_{I(CLK)}$	Input voltage, CLK	0		1.9	V
I_{OH} / I_{OL}	Output current	$V_{DDout} = 3.3$ V		±12	mA
		$V_{DDout} = 2.5$ V		±10	
		$V_{DDout} = 1.8$ V		±8	
C_L	Output load LVCMOS			10	pF
T_A	Operating free-air temperature	-40		85	°C
CRYSTAL AND VCXO⁽¹⁾					
f_{Xtal}	Crystal input frequency (fundamental mode)	8	27	32	MHz
ESR	Effective series resistance			100	Ω
f_{PR}	Pulling ($0 \text{ V} \leq V_{ctrl} \leq 1.8 \text{ V}$) ⁽²⁾	±120	±150		ppm
	Frequency control voltage, V_{ctrl}	0		V_{DD}	V
C_0/C_1	Pullability ratio			220	

- (1) For more information about VCXO configuration, and crystal recommendation, see [VCXO Application Guideline for CDCE\(L\)9xx Family](#) (SCAA085).
- (2) Pulling range depends on crystal-type, on-chip crystal load capacitance and PCB stray capacitance; pulling range of min ±120 ppm applies for crystal listed in [VCXO Application Guideline for CDCE\(L\)9xx Family](#) (SCAA085).

Recommended Operating Conditions (continued)

		MIN	NOM	MAX	UNIT
C_L	On-chip load capacitance at Xin and Xout	0		20	pF

6.4 Thermal Information

THERMAL METRIC ⁽¹⁾		CDCE937, CDCEL937	UNIT
		PW (TSSOP)	
		20 PINS	
$R_{\theta JA}$	Junction-to-ambient thermal resistance	89.04	°C/W
$R_{\theta JC(top)}$	Junction-to-case (top) thermal resistance	31.33	°C/W
$R_{\theta JB}$	Junction-to-board thermal resistance	54.6	°C/W
Ψ_{JT}	Junction-to-top characterization parameter	0.8	°C/W
Ψ_{JB}	Junction-to-board characterization parameter	48.8	°C/W
$R_{\theta JC(bot)}$	Junction-to-case (bottom) thermal resistance	—	°C/W

(1) For more information about traditional and new thermal metrics, see the [Semiconductor and IC Package Thermal Metrics](#) application report.

6.5 Electrical Characteristics

over recommended operating free-air temperature range (unless otherwise noted)

PARAMETER		TEST CONDITIONS	MIN	TYP ⁽¹⁾	MAX	UNIT
I_{DD}	Supply current (see Figure 1)	All outputs off, $f_{(CLK)} = 27$ MHz, $f_{(VCO)} = 135$ MHz	All PLLS on		29	mA
			Per PLL		9	
I_{DDOUT}	Output supply current (see Figure 2 and Figure 3)	No load, all outputs on, $f_{OUT} = 27$ MHz	CDCE937, $V_{DDOUT} = 3.3$ V		3.1	mA
			CDCEL937, $V_{DDOUT} = 1.8$ V		1.5	
$I_{DD(PD)}$	Power-down current	Every circuit powered down except SDA/SCL, $f_{IN} = 0$ MHz, $V_{DD} = 1.9$ V			50	μA
$V_{(PUC)}$	Supply voltage Vdd threshold for power-up control circuit		0.85		1.45	V
$f_{(VCO)}$	VCO frequency range of PLL		80		230	MHz
f_{OUT}	LVCMOS output frequency	$V_{DDOUT} = 3.3$ V			230	MHz
		$V_{DDOUT} = 1.8$ V			230	
LVCMOS PARAMETER						
V_{IK}	LVCMOS input voltage	$V_{DD} = 1.7$ V, $I_I = -18$ mA			-1.2	V
I_I	LVCMOS Input current	$V_I = 0$ V or V_{DD} , $V_{DD} = 1.9$ V			±5	μA
I_{IH}	LVCMOS Input current for S0/S1/S2	$V_I = V_{DD}$, $V_{DD} = 1.9$ V			5	μA
I_{IL}	LVCMOS Input current for S0/S1/S2	$V_I = 0$ V, $V_{DD} = 1.9$ V			-4	μA
C_I	Input capacitance at Xin/Clk	$V_{I(CLK)} = 0$ V or V_{DD}			6	pF
	Input capacitance at Xout	$V_{I(Xout)} = 0$ V or V_{DD}			2	
	Input capacitance at S0/S1/S2	$V_{IS} = 0$ V or V_{DD}			3	
CDCE937 – LVCMOS FOR Vddout = 3.3 V						
V_{OH}	LVCMOS high-level output voltage	$V_{DDOUT} = 3$ V, $I_{OH} = -0.1$ mA			2.9	V
		$V_{DDOUT} = 3$ V, $I_{OH} = -8$ mA			2.4	
		$V_{DDOUT} = 3$ V, $I_{OH} = -12$ mA			2.2	
V_{OL}	LVCMOS low-level output voltage	$V_{DDOUT} = 3$ V, $I_{OL} = 0.1$ mA			0.1	V
		$V_{DDOUT} = 3$ V, $I_{OL} = 8$ mA			0.5	
		$V_{DDOUT} = 3$ V, $I_{OL} = 12$ mA			0.8	
t_{PLH}, t_{PHL}	Propagation delay	All PLL bypass			3.2	ns
t_r/t_f	Rise and fall time	$V_{DDOUT} = 3.3$ V (20%–80%)			0.6	ns

(1) All typical values are at respective nominal V_{DD} .

Electrical Characteristics (continued)

over recommended operating free-air temperature range (unless otherwise noted)

PARAMETER		TEST CONDITIONS	MIN	TYP ⁽¹⁾	MAX	UNIT
t _{jitter(cc)}	Cycle-to-cycle jitter ⁽²⁾⁽³⁾	1 PLL switching, Y2-to-Y3		60	90	ps
		3 PLL switching, Y2-to-Y7		100	150	
t _{jitter(per)}	Peak-to-peak period jitter ⁽³⁾	1 PLL switching, Y2-to-Y3		70	100	ps
		3 PLL switching, Y2-to-Y7		120	180	
t _{sk(o)}	Output skew ⁽⁴⁾ (see Table 2)	f _{OUT} = 50 MHz, Y1-to-Y3			60	ps
		f _{OUT} = 50 MHz, Y2-to-Y5			160	
odc	Output duty cycle ⁽⁵⁾	f _{VCO} = 100 MHz, Pdiv = 1	45%		55%	
CDCE937 – LVC MOS FOR V_{ddout} = 2.5 V						
V _{OH}	LVC MOS high-level output voltage	V _{ddout} = 2.3 V, I _{OH} = –0.1 mA		2.2		V
		V _{ddout} = 2.3 V, I _{OH} = –6 mA		1.7		
		V _{ddout} = 2.3 V, I _{OH} = –10 mA		1.6		
V _{OL}	LVC MOS low-level output voltage	V _{ddout} = 2.3 V, I _{OL} = 0.1 mA			0.1	V
		V _{ddout} = 2.3 V, I _{OL} = 6 mA			0.5	
		V _{ddout} = 2.3 V, I _{OL} = 10 mA			0.7	
t _{PLH} , t _{PHL}	Propagation delay	All PLL bypass		3.4		ns
t _r /t _f	Rise and fall time	V _{ddout} = 2.5 V (20%–80%)		0.8		ns
t _{jitter(cc)}	Cycle-to-cycle jitter ⁽²⁾⁽³⁾	1 PLL switching, Y2-to-Y3		60	90	ps
		3 PLL switching, Y2-to-Y7		100	150	
t _{jitter(per)}	Peak-to-peak period jitter ⁽⁴⁾	1 PLL switching, Y2-to-Y3		70	100	ps
		3 PLL switching, Y2-to-Y7		120	180	
t _{sk(o)}	Output skew ⁽⁴⁾ (see Table 2)	f _{OUT} = 50 MHz, Y1-to-Y3			60	ps
		f _{OUT} = 50 MHz, Y2-to-Y5			160	
odc	Output duty cycle ⁽⁵⁾	f _{VCO} = 100 MHz, Pdiv = 1	45%		55%	
CDCEL937 – LVC MOS FOR V_{ddout} = 1.8 V						
V _{OH}	LVC MOS high-level output voltage	V _{ddout} = 1.7 V, I _{OH} = –0.1 mA		1.6		V
		V _{ddout} = 1.7 V, I _{OH} = –4 mA		1.4		
		V _{ddout} = 1.7 V, I _{OH} = –8 mA		1.1		
V _{OL}	LVC MOS low-level output voltage	V _{ddout} = 1.7 V, I _{OL} = 0.1 mA			0.1	V
		V _{ddout} = 1.7 V, I _{OL} = 4 mA			0.3	
		V _{ddout} = 1.7 V, I _{OL} = 8 mA			0.6	
t _{PLH} , t _{PHL}	Propagation delay	All PLL bypass		2.6		ns
t _r /t _f	Rise and fall time	V _{ddout} = 1.8 V (20%–80%)		0.7		ns
t _{jitter(cc)}	Cycle-to-cycle jitter ⁽²⁾⁽³⁾	1 PLL switching, Y2-to-Y3		70	120	ps
		3 PLL switching, Y2-to-Y7		100	150	
t _{jitter(per)}	Peak-to-peak period jitter ⁽³⁾	1 PLL switching, Y2-to-Y3		90	140	ps
		3 PLL switching, Y2-to-Y7		120	190	
t _{sk(o)}	Output skew ⁽⁴⁾ (see Table 2)	f _{OUT} = 50 MHz, Y1-to-Y3			60	ps
		f _{OUT} = 50 MHz, Y2-to-Y5			160	
odc	Output duty cycle ⁽⁵⁾	f _{VCO} = 100 MHz, Pdiv = 1	45%		55%	
SDA AND SCL						
V _{IK}	SCL and SDA input clamp voltage	V _{DD} = 1.7 V; I _I = –18 mA			–1.2	V
I _{IH}	SCL and SDA input current	V _I = V _{DD} ; V _{DD} = 1.9 V			±10	μA
V _{IH}	SDA/SCL input high voltage ⁽⁶⁾		0.7 × V _{DD}			V
V _{IL}	SDA/SCL input low voltage ⁽⁶⁾				0.3 × V _{DD}	V

(2) 10000 cycles.

 (3) Jitter depends on configuration. Data is taken under the following conditions: 1-PLL is f_{IN} = 27 MHz and Y2/3 = 27 MHz (measured at Y2); 3-PLL is f_{IN} = 27 MHz, Y2/3 = 27 MHz (measured at Y2), Y4/5 = 16.384 MHz, and Y6/7 = 74.25 MHz.

 (4) The t_{sk(o)} specification is only valid for equal loading of each bank of outputs, and outputs are generated from the same divider; data taken on rising edge (t_r).

 (5) odc depends on output rise and fall time (t_r/t_f).

(6) SDA and SCL pins are 3.3-V tolerant.

Electrical Characteristics (continued)

over recommended operating free-air temperature range (unless otherwise noted)

PARAMETER		TEST CONDITIONS	MIN	TYP ⁽¹⁾	MAX	UNIT
V _{OL}	SDA low-level output voltage	I _{OL} = 3 mA, V _{DD} = 1.7 V			0.2 × V _{DD}	V
C _I	SCL/SDA Input capacitance	V _I = 0 V or V _{DD}		3	10	pF

6.6 Timing Requirements: CLK_IN

over operating free-air temperature range (unless otherwise noted)

		MIN	NOM	MAX	UNIT
f _{CLK}	LVCMOS clock input frequency	PLL bypass mode		160	MHz
		PLL mode	8	160	
t _r / t _f	Rise and fall time CLK signal (20% to 80%)			3	ns
duty _{CLK}	Duty cycle CLK at V _{DD} /2	40%		60%	

6.7 Timing Requirements: SDA/SCL

 over operating free-air temperature range (unless otherwise noted; see [Figure 7](#))

		MIN	NOM	MAX	UNIT
f _{SCL}	SCL clock frequency	Standard mode	0	100	kHz
		Fast mode	0	400	
t _{su} (START)	START setup time (SCL high before SDA low)	Standard mode	4.7		μs
		Fast mode	0.6		
t _h (START)	START hold time (SCL low after SDA low)	Standard mode	4		μs
		Fast mode	0.6		
t _w (SCLL)	SCL low-pulse duration	Standard mode	4.7		μs
		Fast mode	1.3		
t _w (SCLH)	SCL high-pulse duration	Standard mode	4		μs
		Fast mode	0.6		
t _h (SDA)	SDA hold time (SDA valid after SCL low)	Standard mode	0	3.45	μs
		Fast mode	0	0.9	
t _{su} (SDA)	SDA setup time	Standard mode	250		ns
		Fast mode	100		
t _r	SCL/SDA input rise time	Standard mode		1000	ns
		Fast mode		300	
t _f	SCL/SDA input fall time	Standard mode		300	ns
		Fast mode		300	
t _{su} (STOP)	STOP setup time	Standard mode	4		μs
		Fast mode	0.6		
t _{BUS}	Bus free time between a STOP and START condition	Standard mode	4.7		μs
		Fast mode	1.3		

6.8 EEPROM Specification

		MIN	TYP	MAX	UNIT
EEcyc	Programming cycles of EEPROM	1000			cycles
EEret	Data retention	10			years

6.9 Typical Characteristics

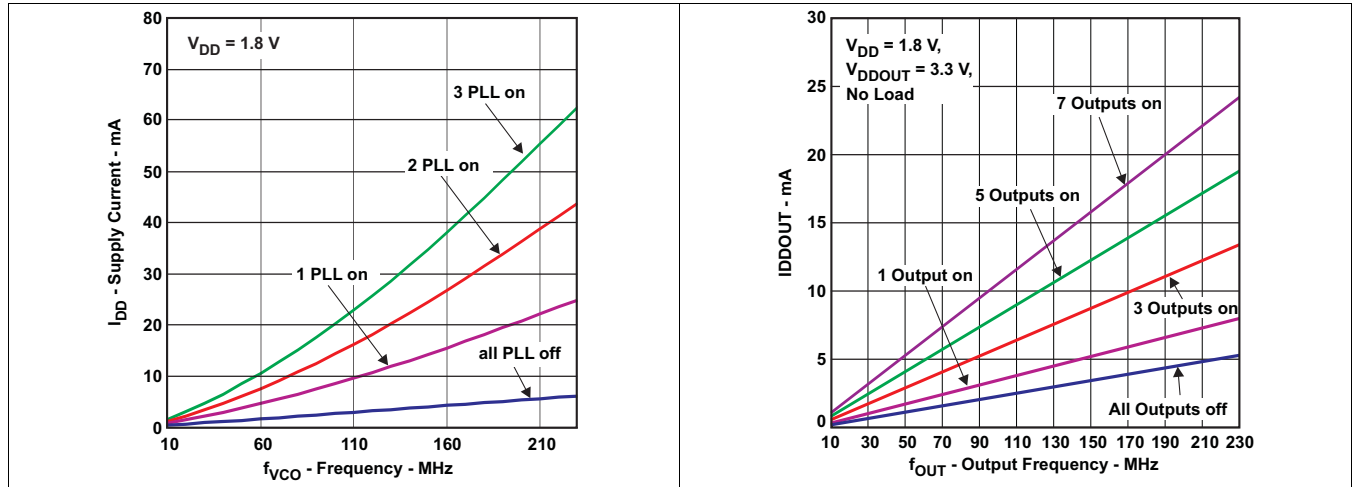

Figure 1. CDCE937 Supply Current vs PLL Frequency

Figure 2. CDCE937 Output Current vs Output Frequency

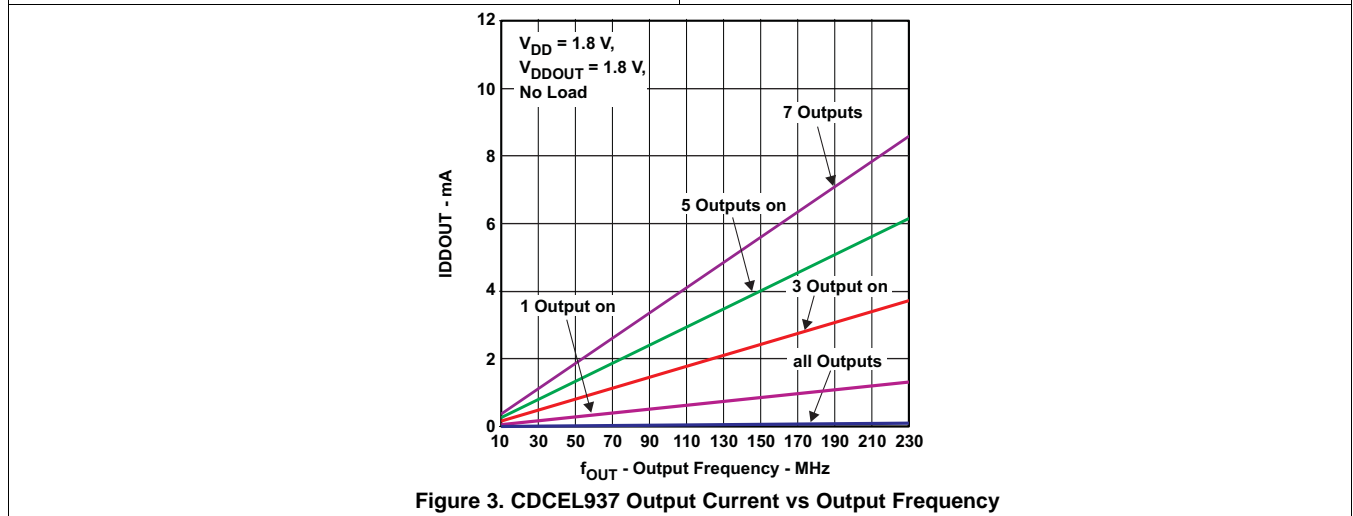
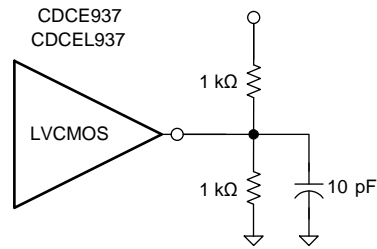

Figure 3. CDCEL937 Output Current vs Output Frequency

7 Parameter Measurement Information



Copyright © 2016, Texas Instruments Incorporated

Figure 4. Test Load

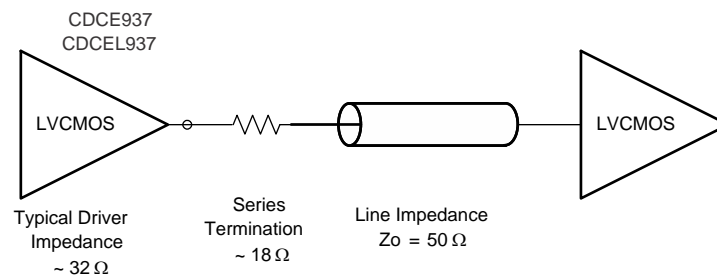

Copyright © 2016, Texas Instruments Incorporated

Figure 5. Test Load for 50-Ω Board Environment

8 Detailed Description

8.1 Overview

The CDCE937 and CDCEL937 devices are modular PLL-based, low-cost, high-performance, programmable clock synthesizers, multipliers, and dividers. They generate up to seven output clocks from a single input frequency. Each output can be programmed in-system for any clock frequency up to 230 MHz, using one of the three integrated configurable PLLs. The CDCx937 has separate output supply pins, VDDOUT, which is 1.8 V for CDCEL937 and 2.5 V to 3.3 V for CDCE937.

The input accepts an external crystal or LVCMOS clock signal. If an external crystal is used, an on-chip load capacitor is adequate for most applications. The value of the load capacitor is programmable from 0 to 20 pF.

Additionally, a selectable on-chip VCXO allows synchronization of the output frequency to an external control signal, that is, the PWM signal.

The deep M/N divider ratio allows the generation of 0 ppm audio/video, networking (WLAN, BlueTooth, Ethernet, GPS) or Interface (USB, IEEE1394, Memory Stick) clocks from a reference input frequency such as 27 MHz.

All PLLs supports SSC (Spread-Spectrum Clocking). SSC can be Center-Spread or Down-Spread clocking which is a common technique to reduce electro-magnetic interference (EMI).

Based on the PLL frequency and the divider settings, the internal loop filter components are automatically adjusted to achieve high stability and optimized jitter transfer characteristic of each PLL.

The device supports non-volatile EEPROM programming for ease-customized application. It is preset to a factory default configuration (see [Default Device Setting](#)). It can be reprogrammed to a different application configuration before PCB assembly, or reprogrammed by in-system programming. All device settings are programmable through SDA/SCL bus, a 2-wire serial interface.

Three programmable control inputs, S0, S1 and S2, can be used to control various aspects of operation including frequency selection changing the SSC parameters to lower EMI, PLL bypass, power down, and choosing between low level or 3-state for output-disable function.

The CDCx937 operates in a 1.8-V environment. It is characterized for operation from -40°C to 85°C .

8.2 Functional Block Diagram

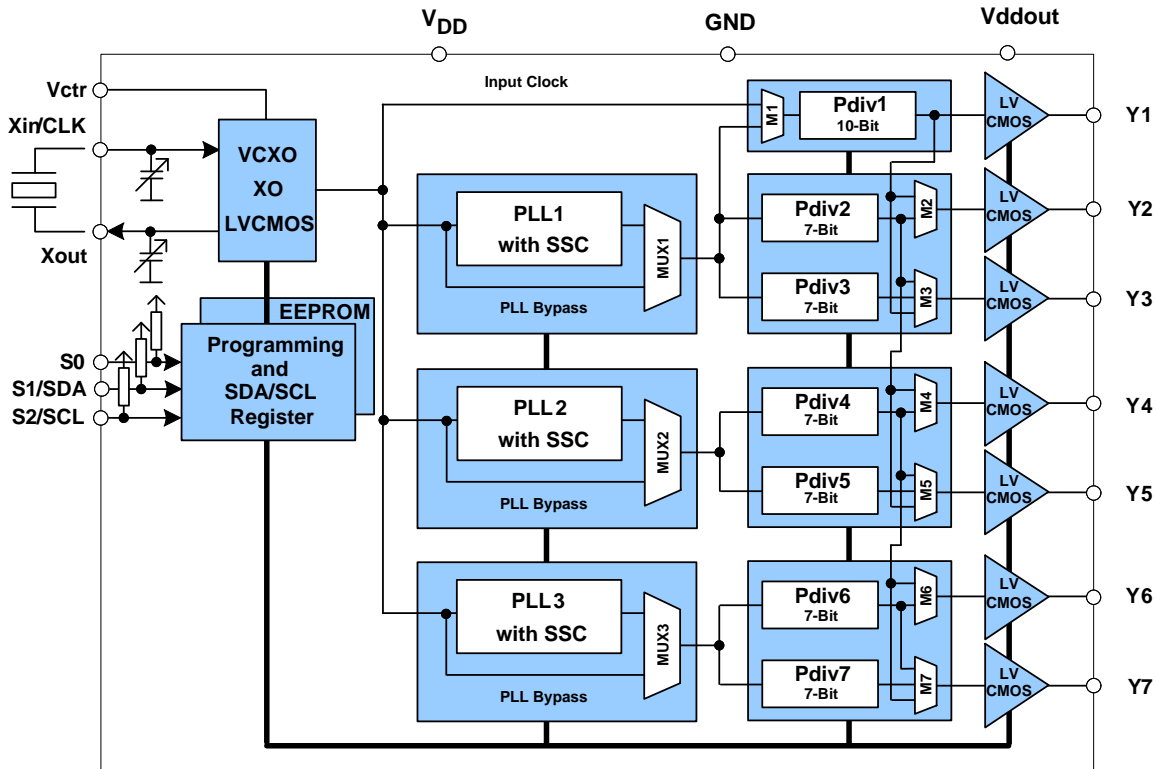

Copyright © 2016, Texas Instruments Incorporated

8.3 Feature Description

8.3.1 Control Terminal Setting

The CDCE937 has three user-definable control terminals (S0, S1, and S2) which allow external control of device settings. They can be programmed to any of the following setting:

- Spread spectrum clocking selection → spread type and spread amount selection
- Frequency selection → switching between any of two user-defined frequencies
- Output state selection → output configuration and power down control

The user can predefine up to eight different control settings. [Table 1](#) and [Table 2](#) explain these settings.

Table 1. Control Terminal Definition

EXTERNAL CONTROL BITS	PLL1 SETTING			PLL2 SETTING			PLL3 SETTING			Y1 SETTING
	PLL Frequency Selection	SSC Selection	Output Y2/Y3 Selection	PLL Frequency Selection	SSC Selection	Output Y4/Y5 Selection	PLL Frequency Selection	SSC Selection	Output Y6/Y7 Selection	Output Y1 and Power-Down Selection
Control Function										

Table 2. PLLx Setting (Can Be Selected for Each PLL Individual)

SSC SELECTION (CENTER/DOWN) ⁽¹⁾				
SSCx [3-bits]			CENTER	DOWN
0	0	0	0% (off)	0% (off)
0	0	1	±0.25%	-0.25%
0	1	0	±0.5%	-0.5%

(1) Center/Down-Spread, Frequency0/1 and State0/1 are user-definable in PLLx Configuration Register

Table 2. PLLx Setting (Can Be Selected for Each PLL Individual) (continued)

SSC SELECTION (CENTER/DOWN) ⁽¹⁾				
SSCx [3-bits]			CENTER	DOWN
0	1	1	±0.75%	–0.75%
1	0	0	±1%	–1%
1	0	1	±1.25%	–1.25%
1	1	0	±1.5%	–1.5%
1	1	1	±2%	–2%
FREQUENCY SELECTION ⁽²⁾				
FSx		FUNCTION		
0		Frequency0		
1		Frequency1		
OUTPUT SELECTION ⁽³⁾ (Y2 ... Y7)				
YxYx		FUNCTION		
0		State0		
1		State1		

(2) Frequency0 and Frequency1 can be any frequency within the specified f_{VCO} range

(3) State0/1 selection is valid for both outputs of the corresponding PLL module and can be power down, 3-state, low or active

Table 3. Y1 Setting⁽¹⁾

Y1 SELECTION	
Y1	FUNCTION
0	State 0
1	State 1

(1) State0 and State1 are user definable in Generic Configuration Register and can be power down, 3-state, low, or active.

S1/SDA and S2/SCL pins of the CDCEx937 are dual function pins. In default configuration they are defined as SDA/SCL for the serial interface. They can be programmed as control-pins (S1/S2) by setting the relevant bits in the EEPROM. Note that the changes to the Control register (Bit [6] of Byte [02]) have no effect until they are written into the EEPROM.

Once they are set as control pins, the serial programming interface is no longer available. However, if V_{DDOUT} is forced to GND, the two control-pins, S1 and S2, temporarily act as serial programming pins (SDA/SCL).

S0 is not a multi-use pin, it is a control pin only.

8.3.2 Default Device Setting

The internal EEPROM of CDCEx937 is preconfigured as shown in [Figure 6](#). (The input frequency is passed through to the output as a default.) This allows the device to operate in default mode without the extra production step of program it. The default setting appears after power is supplied or after power-down or power-up sequence until it is reprogrammed by the user to a different application configuration. A new register setting is programmed through the serial SDA/SCL Interface.

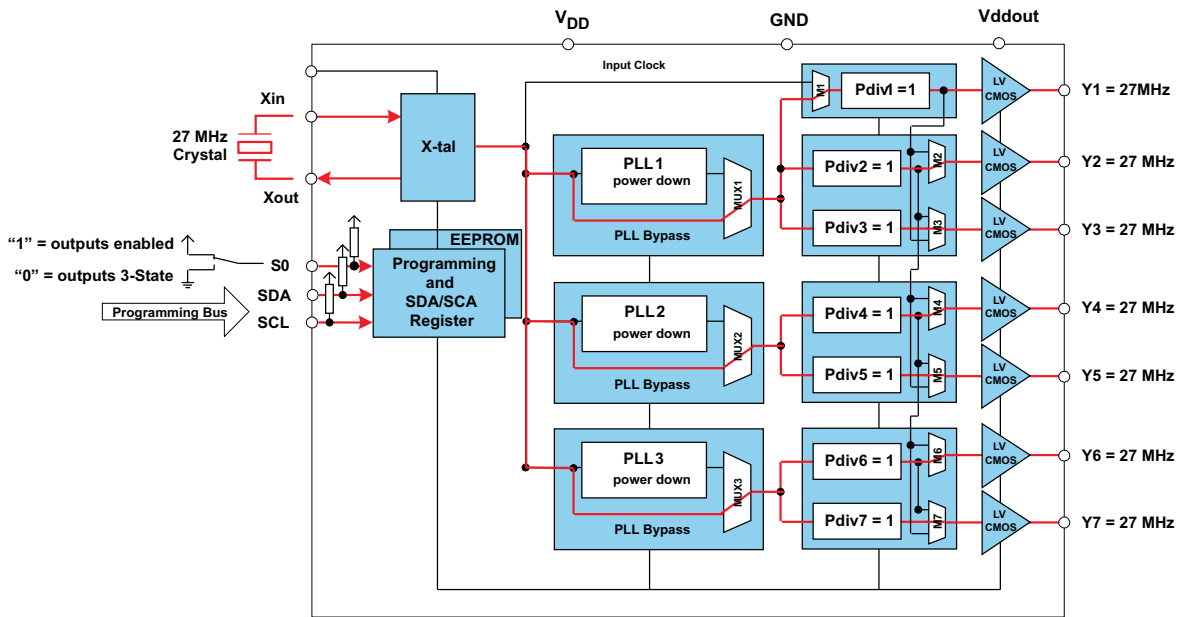

Figure 6. Default Device Setting

Table 4 shows the factory default setting for the Control Terminal Register (external control pins). In normal operation, all 8 register settings are available, but in the default configuration only the first two settings (0 and 1) can be selected with S0, as S1 and S2 configured as programming pins in default mode.

Table 4. Factory Default Setting for Control Terminal Register⁽¹⁾

EXTERNAL CONTROL PINS			Y1	PLL1 SETTINGS			PLL2 SETTINGS			PLL3 SETTINGS		
			OUTPUT SELECTION	FREQUENCY SELECTION	SSC SELECTION	OUTPUT SELECTION	FREQUENCY SELECTION	SSC SELECTION	OUTPUT SELECTION	FREQUENCY SELECTION	SSC SELECTION	OUTPUT SELECTION
S2	S1	S0	Y1	FS1	SSC1	Y2Y3	FS2	SSC2	Y4Y5	FS3	SSC3	Y6Y7
SCL (I2C)	SDA (I2C)	0	3-state	$f_{VCO1,0}$	off	3-state	$f_{VCO2,0}$	off	3-state	$f_{VCO1,0}$	off	3-state
SCL (I2C)	SDA (I2C)	1	enabled	$f_{VCO1,0}$	off	enabled	$f_{VCO2,0}$	off	enabled	$f_{VCO1,0}$	off	enabled

(1) In default mode or when programmed respectively, S1 and S2 act as serial programming interface, SDA/SCL. They do not have any control-pin function but they are internally interpreted as if S1=0 and S2=0. However, S0 is a control-pin which in the default mode switches all outputs ON or OFF (as previously predefined).

8.3.3 SDA/SCL Serial Interface

The CDCE937 operates as a slave device of the 2-wire serial SDA/SCL bus, compatible with the popular SMBus or I²C specification. It operates in the standard-mode transfer (up to 100 kbit/s) and fast-mode transfer (up to 400kbit/s) and supports 7-bit addressing.

The S1/SDA and S2/SCL pins of the CDC9xx are dual function pins. In the default configuration they are used as SDA/SCL serial programming interface. They can be reprogrammed as general purpose control pins, S1 and S2, by changing the corresponding EEPROM setting, Byte 02, Bit [6].

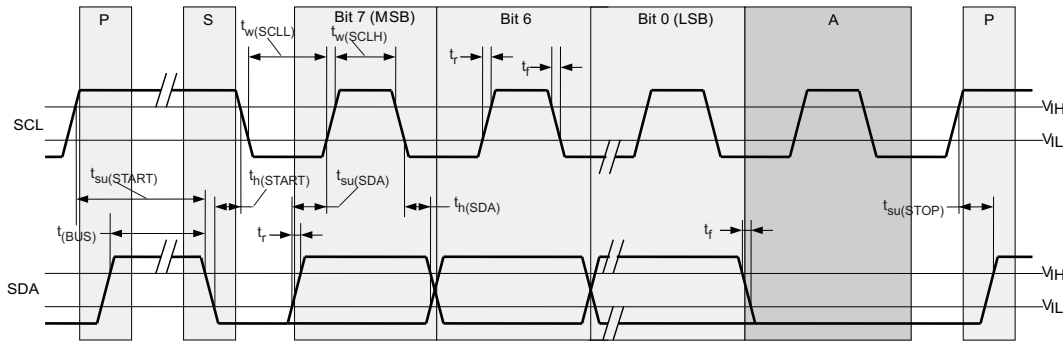

Figure 7. Timing Diagram for SDA/SCL Serial Control Interface

8.3.4 Data Protocol

The device supports *Byte Write and Byte Read* and *Block Write and Block Read* operations.

For *Byte Write/Read* operations, the system controller can individually access addressed bytes.

For *Block Write/Read* operations, the bytes are accessed in sequential order from lowest to highest byte (with most significant bit first) with the ability to stop after any complete byte has been transferred. The numbers of Bytes read-out are defined by Byte Count in the Generic Configuration Register. At Block Read instruction all bytes defined in the Byte Count has to be readout to correctly finish the read cycle.

Once a byte has been sent, it is written into the internal register and is effective immediately. This applies to each transferred byte independent of whether this is a *Byte Write* or a *Block Write* sequence.

If the EEPROM Write Cycle is initiated, the internal SDA register contents are written into the EEPROM. During this write cycle, data is not accepted at the SDA/SCL bus until the write cycle is completed. However, data can be read during the programming sequence (Byte Read or Block Read). The programming status can be monitored by reading *EEPIP*, Byte 01–Bit [6].

The offset of the indexed byte is encoded in the command code, as described in [Table 5](#).

Table 5. Slave Receiver Address (7 Bits)

DEVICE	A6	A5	A4	A3	A2	A1 ⁽¹⁾	A0 ⁽¹⁾	R/W
CDCEx913	1	1	0	0	1	0	1	1/0
CDCEx925	1	1	0	0	1	0	0	1/0
CDCEx937	1	1	0	1	1	0	1	1/0
CDCEx949	1	1	0	1	1	0	0	1/0

(1) Address bits A0 and A1 are programmable through the SDA/SCL bus (Byte 01, Bit [1:0]). This allows addressing up to 4 devices connected to the same SDA/SCL bus. The least-significant bit of the address byte designates a write or read operation.

8.4 Device Functional Modes

8.4.1 SDA/SCL Hardware Interface

[Figure 8](#) shows how the CDCEx937 clock synthesizer is connected to the SDA/SCL serial interface bus. Multiple devices can be connected to the bus but the speed may require reduction (400 kHz is the maximum) if many devices are connected.

Note that the pullup resistors (R_P) depends on the supply voltage, bus capacitance, and number of connected devices. The recommended pullup value is 4.7 k Ω . It must meet the minimum sink current of 3 mA at $V_{OLmax} = 0.4$ V for the output stages (for more details, see [SMBus](#) or [I²C Bus](#) specification).

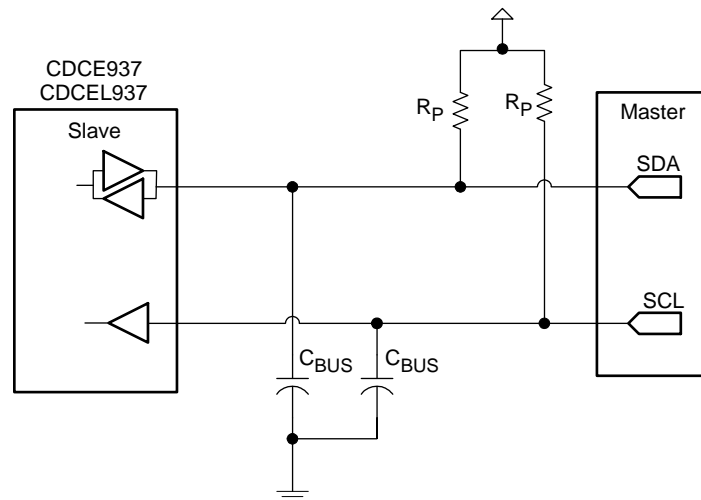
Device Functional Modes (continued)

Copyright © 2016, Texas Instruments Incorporated

Figure 8. SDA/SCL Hardware Interface
8.5 Programming
Table 6. Command Code Definition

BIT	DESCRIPTION
7	0 = <i>Block Read</i> or <i>Block Write</i> operation 1 = <i>Byte Read</i> or <i>Byte Write</i> operation
(6:0)	Byte Offset for <i>Byte Read</i> , <i>Block Read</i> , <i>Byte Write</i> and <i>Block Write</i> operation.

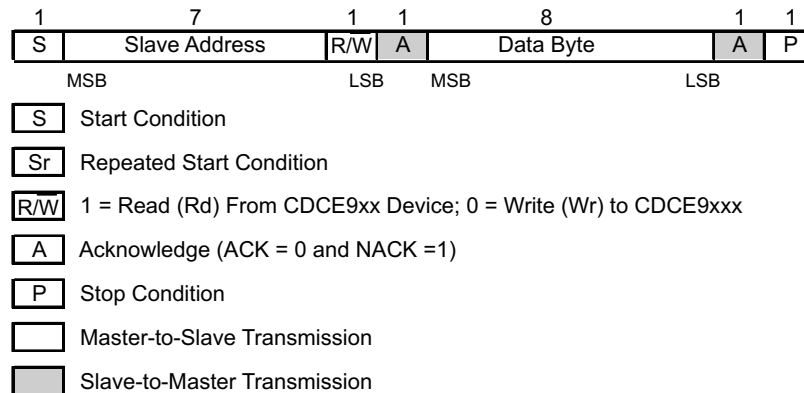
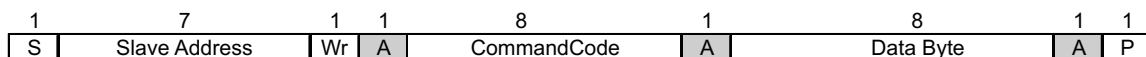
Figure 9. Generic Programming Sequence

Figure 10. Byte Write Protocol

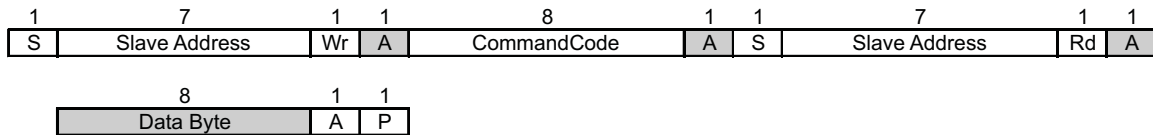
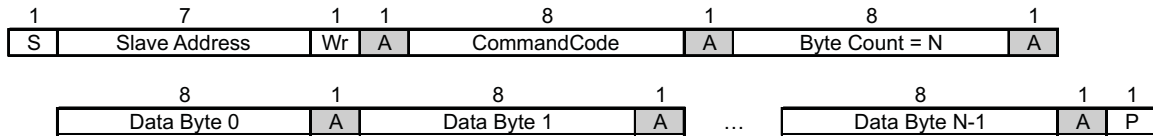

Figure 11. Byte Read Protocol



Data byte 0 bits [7:0] is reserved for Revision Code and Vendor Identification. Also, it is used for internal test purpose and must not be overwritten.

Figure 12. Block Write Protocol

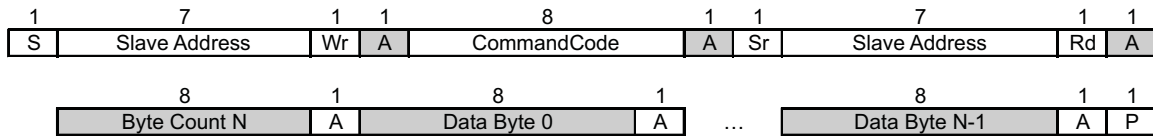

Figure 13. Block Read Protocol

8.6 Register Maps

8.6.1 SDA/SCL Configuration Registers

The clock input, control pins, PLLs, and output stages are user configurable. The following tables and explanations describe the programmable functions of the CDCE937. All settings can be manually written into the device through the SDA/SCL bus or easily programmed by using the TI Pro-Clock™ software. TI Pro-Clock™ software allows the user to quickly make all settings and automatically calculates the values for optimized performance at lowest jitter.

Table 7. SDA and SCL Registers

ADDRESS OFFSET	REGISTER DESCRIPTION	TABLE
00h	Generic Configuration Register	Table 9
10h	PLL1 Configuration Register	Table 10
20h	PLL2 Configuration Register	Table 11
30h	PLL3 Configuration Register	Table 12

The grey-highlighted bits, described in the Configuration Registers tables in the following pages, belong to the Control Terminal Register. The user can predefine up to eight different control settings. These settings then can be selected by the external control pins, S0, S1, and S2 (see [Control Terminal Setting](#)).

Table 8. Configuration Register, External Control Terminals

	EXTERNAL CONTROL PINS			Y1	PLL1 SETTINGS			PLL2 SETTINGS			PLL3 SETTINGS		
	S2	S1	S0	OUTPUT SELECTION	FREQ. SELECTION	SSC SELECTION	OUTPUT SELECTION	FREQ. SELECTION	SSC SELECTION	OUTPUT SELECTION	FREQ. SELECTION	SSC SELECTION	OUTPUT SELECTION
	Y1	FS1	SSC1	Y2Y3	FS2	SSC2	Y4Y5	FS3	SSC3	Y6Y7			
0	0	0	0	Y1_0	FS1_0	SSC1_0	Y2Y3_0	FS2_0	SSC2_0	Y4Y5_0	FS3_0	SSC3_0	Y6Y7_0
1	0	0	1	Y1_1	FS1_1	SSC1_1	Y2Y3_1	FS2_1	SSC2_1	Y4Y5_1	FS3_1	SSC3_1	Y6Y7_1
2	0	1	0	Y1_2	FS1_2	SSC1_2	Y2Y3_2	FS2_2	SSC2_2	Y4Y5_2	FS3_2	SSC3_2	Y6Y7_2
3	0	1	1	Y1_3	FS1_3	SSC1_3	Y2Y3_3	FS2_3	SSC2_3	Y4Y5_3	FS3_3	SSC3_3	Y6Y7_3
4	1	0	0	Y1_4	FS1_4	SSC1_4	Y2Y3_4	FS2_4	SSC2_4	Y4Y5_4	FS3_4	SSC3_4	Y6Y7_4
5	1	0	1	Y1_5	FS1_5	SSC1_5	Y2Y3_5	FS2_5	SSC2_5	Y4Y5_5	FS3_5	SSC3_5	Y6Y7_5
6	1	1	0	Y1_6	FS1_6	SSC1_6	Y2Y3_6	FS2_6	SSC2_6	Y4Y5_6	FS3_6	SSC3_6	Y6Y7_6
7	1	1	1	Y1_7	FS1_7	SSC1_7	Y2Y3_7	FS2_7	SSC2_7	Y4Y5_7	FS3_7	SSC3_7	Y6Y7_7
Address Offset ⁽¹⁾				04h	13h	10h–12h	15h	23h	20h–22h	25h	33h	30h–32h	35h

(1) Address Offset refers to the byte address in the Configuration Register in the following pages.

Table 9. Generic Configuration Register

OFFSET ⁽¹⁾	BIT ⁽²⁾	ACRONYM	DEFAULT ⁽³⁾	DESCRIPTION
00h	7	E_EL	Xb	Device identification (read-only): 1 is CDCE937 (3.3 V), 0 is CDCEL937 (1.8 V)
	6:4	RID	Xb	Revision Identification Number (read only)
	3:0	VID	1h	Vendor Identification Number (read only)
01h	7	–	0b	Reserved – always write 0
	6	EEPIP	0b	EEPROM Programming Status: ⁽⁴⁾ (read only) 0 – EEPROM programming is completed 1 – EEPROM is in programming mode
	5	EELock	0b	Permanently Lock EEPROM Data ⁽⁵⁾ 0 – EEPROM is not locked 1 – EEPROM is permanently locked
	4	PWDN	0b	Device Power Down (overwrites S0/S1/S2 setting; configuration register settings are unchanged) Note: PWDN cannot be set to 1 in the EEPROM. 0 – device active (PLL1 and all outputs are enabled) 1 – device power down (PLL1 in power down and all outputs in 3-state)
	3:2	INCLK	00b	Input clock selection: 00 – Xtal 01 – VCXO 10 – LVCMOS 11 – reserved
	1:0	SLAVE_ADDR	01b	Programmable Address Bits A0 and A1 of the Slave Receiver Address
02h	7	M1	1b	Clock source selection for output Y1: 0 – input clock 1 – PLL1 clock
	6	SPICON	0b	Operation mode selection for pin 18/19 ⁽⁶⁾ 0 – serial programming interface SDA (pin 19) and SCL (pin 18) 1 – control pins S1 (pin 19) and S2 (pin 18)
	5:4	Y1_ST1	11b	Y1-State0/1 Definition
	3:2	Y1_ST0	01b	00 – device power down (all PLLs in power down and all outputs in 3-State) 01 – Y1 disabled to 3-state 10 – Y1 disabled to low 11 – Y1 enabled
	1:0	Pdiv1 [9:8]	001h	10-Bit Y1-Output-Divider Pdiv1: 0 – divider reset and stand-by 1-to-1023 – divider value
03h	7:0	Pdiv1 [7:0]		

- (1) Writing data beyond '40h' may affect device function.
- (2) All data transferred with the MSB first.
- (3) Unless customer-specific setting.
- (4) During EEPROM programming, no data is allowed to be sent to the device through the SDA/SCL bus until the programming sequence is completed. However, data can be read out during the programming sequence (Byte Read or Block Read).
- (5) If this bit is set to high in the EEPROM, the actual data in the EEPROM is permanently locked. There is no further programming possible. However, data can still be written through the SDA/SCL bus to the internal register to change device function on the fly. But new data can no longer be saved to the EEPROM. EELock is effective only, if written into the EEPROM!
- (6) Selection of control pins is effective only if written into the EEPROM. Once written into the EEPROM, the serial programming pins are no longer available. However, if V_{DDOUT} is forced to GND, the two control pins, S1 and S2, temporarily act as serial programming pins (SDA/SCL), and the two slave receiver address bits are reset to A0 = 0 and A1 = 0.

Table 9. Generic Configuration Register (continued)

OFFSET ⁽¹⁾	BIT ⁽²⁾	ACRONYM	DEFAULT ⁽³⁾	DESCRIPTION
04h	7	Y1_7	0b	Y1_ST0/Y1_ST1 State Selection ⁽⁷⁾ 0 – State0 (predefined by Y1_ST0) 1 – State1 (predefined by Y1_ST1)
	6	Y1_6	0b	
	5	Y1_5	0b	
	4	Y1_4	0b	
	3	Y1_3	0b	
	2	Y1_2	0b	
	1	Y1_1	1b	
	0	Y1_0	0b	
05h	7:3	XCSEL	0Ah	Crystal Load Capacitor Selection ⁽⁸⁾ 00h → 0 pF 01h → 1 pF 02h → 2 pF : 14h-to-1Fh → 20 pF
	2:0		0b	Reserved – do not write other than 0
06h	7:1	BCOUNT	40h	7-Bit Byte Count (defines the number of bytes which is sent from this device at the next Block Read transfer); all bytes have to be read out to correctly finish the read cycle.)
	0	EEWRITE	0b	Initiate EEPROM Write Cycle ⁽⁴⁾ ⁽⁹⁾ 0 – no EEPROM write cycle 1 – start EEPROM write cycle (internal configuration register is saved to the EEPROM)
07h-0Fh		—	0h	Unused address range

- (7) These are the bits of the Control Terminal Register. The user can predefine up to eight different control settings. These settings then can be selected by the external control pins, S0, S1, and S2.
- (8) The internal load capacitor (C1, C2) has to be used to achieve the best clock performance. External capacitors must be used only to finely adjust C_L by a few pF's. The value of C_L can be programmed with a resolution of 1 pF for a crystal load range of 0 pF to 20 pF. For C_L > 20 pF, use additional external capacitors. Also, the value of the device input capacitance has to be considered which always adds 1.5 pF (6 pF//2 pF) to the selected C_L. For more information about VCXO configuration and crystal recommendation, see [VCXO Application Guideline for CDCE\(L\)9xx Family](#) (SCAA085).
- (9) Note: The EEPROM WRITE bit must be sent last. This ensures that the content of all internal registers are stored in the EEPROM. The EEWRITE cycle is initiated with the rising edge of the EEWRITE bit. A static level high does not trigger an EEPROM WRITE cycle. The EEWRITE bit has to be reset to low after the programming is completed. The programming status can be monitored by reading out EEPIP. If EELOCK is set to high, no EEPROM programming is possible.

Table 10. PLL1 Configuration Register

OFFSET ⁽¹⁾	BIT ⁽²⁾	ACRONYM	DEFAULT ⁽³⁾	DESCRIPTION																		
10h	7:5	SSC1_7 [2:0]	000b	SSC1: PLL1 SSC Selection (Modulation Amount) ⁽⁴⁾ <table border="0"> <tr> <td>Down</td> <td>Center</td> </tr> <tr> <td>000 (off)</td> <td>000 (off)</td> </tr> <tr> <td>001 – 0.25%</td> <td>001 ± 0.25%</td> </tr> <tr> <td>010 – 0.5%</td> <td>010 ± 0.5%</td> </tr> <tr> <td>011 – 0.75%</td> <td>011 ± 0.75%</td> </tr> <tr> <td>100 – 1.0%</td> <td>100 ± 1.0%</td> </tr> <tr> <td>101 – 1.25%</td> <td>101 ± 1.25%</td> </tr> <tr> <td>110 – 1.5%</td> <td>110 ± 1.5%</td> </tr> <tr> <td>111 – 2.0%</td> <td>111 ± 2.0%</td> </tr> </table>	Down	Center	000 (off)	000 (off)	001 – 0.25%	001 ± 0.25%	010 – 0.5%	010 ± 0.5%	011 – 0.75%	011 ± 0.75%	100 – 1.0%	100 ± 1.0%	101 – 1.25%	101 ± 1.25%	110 – 1.5%	110 ± 1.5%	111 – 2.0%	111 ± 2.0%
	Down	Center																				
	000 (off)	000 (off)																				
001 – 0.25%	001 ± 0.25%																					
010 – 0.5%	010 ± 0.5%																					
011 – 0.75%	011 ± 0.75%																					
100 – 1.0%	100 ± 1.0%																					
101 – 1.25%	101 ± 1.25%																					
110 – 1.5%	110 ± 1.5%																					
111 – 2.0%	111 ± 2.0%																					
4:2	SSC1_6 [2:0]	000b																				
1:0	SSC1_5 [2:1]	000b																				
11h	7	SSC1_5 [0]	000b																			
	6:4	SSC1_4 [2:0]																				
	3:1	SSC1_3 [2:0]																				
	0	SSC1_2 [2]																				
12h	7:6	SSC1_2 [1:0]	000b																			
	5:3	SSC1_1 [2:0]																				
	2:0	SSC1_0 [2:0]																				
13h	7	FS1_7	0b	FS1_x: PLL1 Frequency Selection ⁽⁴⁾ 0 – f _{VC01_0} (predefined by PLL1_0 – Multiplier/Divider value) 1 – f _{VC01_1} (predefined by PLL1_1 – Multiplier/Divider value)																		
	6	FS1_6	0b																			
	5	FS1_5	0b																			
	4	FS1_4	0b																			
	3	FS1_3	0b																			
	2	FS1_2	0b																			
	1	FS1_1	0b																			
0	FS1_0	0b																				

- (1) Writing data beyond 40h may adversely affect device function.
- (2) All data is transferred MSB-first.
- (3) Unless a custom setting is used
- (4) The user can predefine up to eight different control settings. In normal device operation, these settings can be selected by the external control pins, S0, S1, and S2.

Table 10. PLL1 Configuration Register (continued)

OFFSET ⁽¹⁾	BIT ⁽²⁾	ACRONYM	DEFAULT ⁽³⁾	DESCRIPTION
14h	7	MUX1	1b	PLL1 Multiplexer: 0 – PLL1 1 – PLL1 Bypass (PLL1 is in power down)
	6	M2	1b	Output Y2 Multiplexer: 0 – Pdiv1 1 – Pdiv2
	5:4	M3	10b	Output Y3 Multiplexer: 00 – Pdiv1-Divider 01 – Pdiv2-Divider 10 – Pdiv3-Divider 11 – reserved
	3:2	Y2Y3_ST1	11b	Y2, Y3-State0/1 definition: 00 – Y2/Y3 disabled to 3-State (PLL1 is in power down) 01 – Y2/Y3 disabled to 3-State 10 – Y2/Y3 disabled to low 11 – Y2/Y3 enabled
	1:0	Y2Y3_ST0	01b	
15h	7	Y2Y3_7	0b	Y2Y3_x Output State Selection ⁽⁴⁾ 0 – state0 (predefined by Y2Y3_ST0) 1 – state1 (predefined by Y2Y3_ST1)
	6	Y2Y3_6	0b	
	5	Y2Y3_5	0b	
	4	Y2Y3_4	0b	
	3	Y2Y3_3	0b	
	2	Y2Y3_2	0b	
	1	Y2Y3_1	1b	
	0	Y2Y3_0	0b	
16h	7	SSC1DC	0b	PLL1 SSC down/center selection: 0 – down 1 – center
	6:0	Pdiv2	01h	7-Bit Y2-Output-Divider Pdiv2: 0 – reset and stand-by 1-to-127 is divider value
17h	7	—	0b	Reserved – do not write others than 0
	6:0	Pdiv3	01h	7-Bit Y3-Output-Divider Pdiv3: 0 – reset and stand-by 1-to-127 is divider value
18h	7:0	PLL1_0N [11:4]	004h	PLL1_0 ⁽⁵⁾ : 30-Bit Multiplier/Divider value for frequency f_{VCO1_0} (for more information, see PLL Frequency Planning).
19h	7:4	PLL1_0N [3:0]		
	3:0	PLL1_0R [8:5]		
1Ah	7:3	PLL1_0R[4:0]		
	2:0	PLL1_0Q [5:3]		
1Bh	7:5	PLL1_0Q [2:0]	10h	
	4:2	PLL1_0P [2:0]	010b	
	1:0	VCO1_0_RANGE	00b	f_{VCO1_0} range selection: 00 – $f_{VCO1_0} < 125$ MHz 01 – $125 \text{ MHz} \leq f_{VCO1_0} < 150$ MHz 10 – $150 \text{ MHz} \leq f_{VCO1_0} < 175$ MHz 11 – $f_{VCO1_0} \geq 175$ MHz
1Ch	7:0	PLL1_1N [11:4]	004h	PLL1_1 ⁽⁵⁾ : 30-Bit Multiplier/Divider value for frequency f_{VCO1_1} (for more information see PLL Frequency Planning).
1Dh	7:4	PLL1_1N [3:0]		
	3:0	PLL1_1R [8:5]		
1Eh	7:3	PLL1_1R[4:0]		
	2:0	PLL1_1Q [5:3]		
1Fh	7:5	PLL1_1Q [2:0]	10h	
	4:2	PLL1_1P [2:0]	010b	
	1:0	VCO1_1_RANGE	00b	f_{VCO1_1} range selection: 00 – $f_{VCO1_1} < 125$ MHz 01 – $125 \text{ MHz} \leq f_{VCO1_1} < 150$ MHz 10 – $150 \text{ MHz} \leq f_{VCO1_1} < 175$ MHz 11 – $f_{VCO1_1} \geq 175$ MHz

(5) PLL settings limits: $16 \leq q \leq 63$, $0 \leq p \leq 7$, $0 \leq r \leq 511$, $0 < N < 4096$

Table 11. PLL2 Configuration Register

OFFSET ⁽¹⁾	BIT ⁽²⁾	ACRONYM	DEFAULT ⁽³⁾	DESCRIPTION																		
20h	7:5	SSC2_7 [2:0]	000b	SSC2: PLL2 SSC Selection (Modulation Amount) ⁽⁴⁾ <table border="0"> <tr> <td>Down</td> <td>Center</td> </tr> <tr> <td>000 (off)</td> <td>000 (off)</td> </tr> <tr> <td>001 – 0.25%</td> <td>001 ± 0.25%</td> </tr> <tr> <td>010 – 0.5%</td> <td>010 ± 0.5%</td> </tr> <tr> <td>011 – 0.75%</td> <td>011 ± 0.75%</td> </tr> <tr> <td>100 – 1.0%</td> <td>100 ± 1.0%</td> </tr> <tr> <td>101 – 1.25%</td> <td>101 ± 1.25%</td> </tr> <tr> <td>110 – 1.5%</td> <td>110 ± 1.5%</td> </tr> <tr> <td>111 – 2.0%</td> <td>111 ± 2.0%</td> </tr> </table>	Down	Center	000 (off)	000 (off)	001 – 0.25%	001 ± 0.25%	010 – 0.5%	010 ± 0.5%	011 – 0.75%	011 ± 0.75%	100 – 1.0%	100 ± 1.0%	101 – 1.25%	101 ± 1.25%	110 – 1.5%	110 ± 1.5%	111 – 2.0%	111 ± 2.0%
	Down	Center																				
	000 (off)	000 (off)																				
001 – 0.25%	001 ± 0.25%																					
010 – 0.5%	010 ± 0.5%																					
011 – 0.75%	011 ± 0.75%																					
100 – 1.0%	100 ± 1.0%																					
101 – 1.25%	101 ± 1.25%																					
110 – 1.5%	110 ± 1.5%																					
111 – 2.0%	111 ± 2.0%																					
4:2	SSC2_6 [2:0]	000b																				
1:0	SSC2_5 [2:1]	000b																				
7	SSC2_5 [0]																					
21h	6:4	SSC2_4 [2:0]	000b																			
	3:1	SSC2_3 [2:0]	000b																			
	0	SSC2_2 [2]	000b																			
7:6	SSC2_2 [1:0]																					
22h	5:3	SSC2_1 [2:0]		000b																		
	2:0	SSC2_0 [2:0]	000b																			
23h	7	FS2_7	0b	FS2_x: PLL2 Frequency Selection ⁽⁴⁾ 0 – f _{VCO2_0} (predefined by PLL2_0 – Multiplier/Divider value) 1 – f _{VCO2_1} (predefined by PLL2_1 – Multiplier/Divider value)																		
	6	FS2_6	0b																			
	5	FS2_5	0b																			
	4	FS2_4	0b																			
	3	FS2_3	0b																			
	2	FS2_2	0b																			
	1	FS2_1	0b																			
	0	FS2_0	0b																			
24h	7	MUX2	1b	PLL2 Multiplexer: 0 – PLL2 1 – PLL2 Bypass (PLL2 is in power down)																		
	6	M4	1b	Output Y4 Multiplexer: 0 – Pdiv2 1 – Pdiv4																		
	5:4	M5	10b	Output Y5 Multiplexer: 00 – Pdiv2-Divider 01 – Pdiv4-Divider 10 – Pdiv5-Divider 11 – reserved																		
	3:2	Y4Y5_ST1	11b	Y4, Y5-State0/1definition: 00 – Y4/Y5 disabled to 3-State (PLL2 is in power down) 01 – Y4/Y5 disabled to 3-State 10 – Y4/Y5 disabled to low 11 – Y4/Y5 enabled																		
	1:0	Y4Y5_ST0	01b																			
25h	7	Y4Y5_7	0b	Y4Y5_x Output State Selection ⁽⁴⁾ 0 – state0 (predefined by Y4Y5_ST0) 1 – state1 (predefined by Y4Y5_ST1)																		
	6	Y4Y5_6	0b																			
	5	Y4Y5_5	0b																			
	4	Y4Y5_4	0b																			
	3	Y4Y5_3	0b																			
	2	Y4Y5_2	0b																			
	1	Y4Y5_1	1b																			
	0	Y4Y5_0	0b																			
26h	7	SSC2DC	0b	PLL2 SSC down/center selection: 0 – down 1 – center																		
	6:0	Pdiv4	01h	7-Bit Y4-Output-Divider Pdiv4: 0 – reset and stand-by value 1-to-127 – divider value																		
27h	7	—	0b	Reserved – do not write others than 0																		
	6:0	Pdiv5	01h	7-Bit Y5-Output-Divider Pdiv5: 0 – reset and stand-by value 1-to-127 – divider value																		

(1) Writing data beyond 40h may adversely affect device function.

(2) All data is transferred MSB-first.

(3) Unless a custom setting is used

(4) The user can predefine up to eight different control settings. In normal device operation, these settings can be selected by the external control pins, S0, S1, and S2.

Table 11. PLL2 Configuration Register (continued)

OFFSET ⁽¹⁾	BIT ⁽²⁾	ACRONYM	DEFAULT ⁽³⁾	DESCRIPTION
28h	7:0	PLL2_ON [11:4]	004h	PLL2_0 ⁽⁵⁾ : 30-Bit Multiplier/Divider value for frequency f_{VCO2_0} (for more information see PLL Frequency Planning).
29h	7:4	PLL2_ON [3:0]	000h	
	3:0	PLL2_OR [8:5]		
2Ah	7:3	PLL2_OR[4:0]	10h	
	2:0	PLL2_OQ [5:3]		
2Bh	7:5	PLL2_OQ [2:0]	010b	
	4:2	PLL2_OP [2:0]	00b	
	1:0	VCO2_0_RANGE		f_{VCO2_0} range selection: 00 – $f_{VCO2_0} < 125$ MHz 01 – $125 \text{ MHz} \leq f_{VCO2_0} < 150$ MHz 10 – $150 \text{ MHz} \leq f_{VCO2_0} < 175$ MHz 11 – $f_{VCO2_0} \geq 175$ MHz
2Ch	7:0	PLL2_1N [11:4]	004h	PLL2_1 ⁽⁵⁾ : 30-Bit Multiplier/Divider value for frequency f_{VCO2_1} (for more information see PLL Frequency Planning).
2Dh	7:4	PLL2_1N [3:0]	000h	
	3:0	PLL2_1R [8:5]		
2Eh	7:3	PLL2_1R[4:0]	10h	
	2:0	PLL2_1Q [5:3]		
2Fh	7:5	PLL2_1Q [2:0]	010b	
	4:2	PLL2_1P [2:0]	00b	
	1:0	VCO2_1_RANGE		f_{VCO2_1} range selection: 00 – $f_{VCO2_1} < 125$ MHz 01 – $125 \text{ MHz} \leq f_{VCO2_1} < 150$ MHz 10 – $150 \text{ MHz} \leq f_{VCO2_1} < 175$ MHz 11 – $f_{VCO2_1} \geq 175$ MHz

(5) PLL settings limits: $16 \leq q \leq 63$, $0 \leq p \leq 7$, $0 \leq r \leq 511$, $0 < N < 4096$

Table 12. PLL3 Configuration Register

OFFSET ⁽¹⁾	BIT ⁽²⁾	ACRONYM	DEFAULT ⁽³⁾	DESCRIPTION																		
30h	7:5	SSC3_7 [2:0]	000b	SSC3: PLL3 SSC Selection (Modulation Amount) ⁽⁴⁾ <table border="0"> <tr> <td>Down</td> <td>Center</td> </tr> <tr> <td>000 (off)</td> <td>000 (off)</td> </tr> <tr> <td>001 – 0.25%</td> <td>001 ± 0.25%</td> </tr> <tr> <td>010 – 0.5%</td> <td>010 ± 0.5%</td> </tr> <tr> <td>011 – 0.75%</td> <td>011 ± 0.75%</td> </tr> <tr> <td>100 – 1.0%</td> <td>100 ± 1.0%</td> </tr> <tr> <td>101 – 1.25%</td> <td>101 ± 1.25%</td> </tr> <tr> <td>110 – 1.5%</td> <td>110 ± 1.5%</td> </tr> <tr> <td>111 – 2.0%</td> <td>111 ± 2.0%</td> </tr> </table>	Down	Center	000 (off)	000 (off)	001 – 0.25%	001 ± 0.25%	010 – 0.5%	010 ± 0.5%	011 – 0.75%	011 ± 0.75%	100 – 1.0%	100 ± 1.0%	101 – 1.25%	101 ± 1.25%	110 – 1.5%	110 ± 1.5%	111 – 2.0%	111 ± 2.0%
	Down	Center																				
	000 (off)	000 (off)																				
001 – 0.25%	001 ± 0.25%																					
010 – 0.5%	010 ± 0.5%																					
011 – 0.75%	011 ± 0.75%																					
100 – 1.0%	100 ± 1.0%																					
101 – 1.25%	101 ± 1.25%																					
110 – 1.5%	110 ± 1.5%																					
111 – 2.0%	111 ± 2.0%																					
4:2	SSC3_6 [2:0]	000b																				
1:0	SSC3_5 [2:1]	000b																				
31h	7	SSC3_5 [0]	000b																			
	6:4	SSC3_4 [2:0]																				
	3:1	SSC3_3 [2:0]																				
	0	SSC3_2 [2]																				
32h	7:6	SSC3_2 [1:0]	000b																			
	5:3	SSC3_1 [2:0]																				
	2:0	SSC3_0 [2:0]																				
33h	7	FS3_7	0b	FS3_x: PLL3 Frequency Selection ⁽⁴⁾ 0 – f_{VCO3_0} (predefined by PLL3_0 – Multiplier/Divider value) 1 – f_{VCO3_1} (predefined by PLL3_1 – Multiplier/Divider value)																		
	6	FS3_6	0b																			
	5	FS3_5	0b																			
	4	FS3_4	0b																			
	3	FS3_3	0b																			
	2	FS3_2	0b																			
	1	FS3_1	0b																			
	0	FS3_0	0b																			

(1) Writing data beyond 40h may affect device function.

(2) All data is transferred MSB-first.

(3) Unless a custom setting is used

(4) These are the bits of the Control Terminal Register. The user can pre-define up to eight different control settings. At normal device operation, these setting can be selected by the external control pins, S0, S1, and S2.

Table 12. PLL3 Configuration Register (continued)

OFFSET ⁽¹⁾	BIT ⁽²⁾	ACRONYM	DEFAULT ⁽³⁾	DESCRIPTION
34h	7	MUX3	1b	PLL3 Multiplexer: 0 – PLL3 1 – PLL3 Bypass (PLL3 is in power down)
	6	M6	1b	Output Y6 Multiplexer: 0 – Pdiv4 1 – Pdiv6
	5:4	M7	10b	Output Y7 Multiplexer: 00 – Pdiv4-Divider 01 – Pdiv6-Divider 10 – Pdiv7-Divider 11 – reserved
	3:2	Y6Y7_ST1	11b	Y6, Y7- State0/1definition: 00 – Y6/Y7 disabled to 3-State and PLL3 power down 01 – Y6/Y7 disabled to 3-State 10 – Y6/Y7 disabled to low 11 – Y6/Y7 enabled
1:0	Y6Y7_ST0	01b		
35h	7	Y6Y7_7	0b	Y6Y7_x Output State Selection ⁽⁴⁾ 0 – state0 (predefined by Y6Y7_ST0) 1 – state1 (predefined by Y6Y7_ST1)
	6	Y6Y7_6	0b	
	5	Y6Y7_5	0b	
	4	Y6Y7_4	0b	
	3	Y6Y7_3	0b	
	2	Y6Y7_2	0b	
	1	Y6Y7_1	1b	
	0	Y6Y7_0	0b	
36h	7	SSC3DC	0b	PLL3 SSC down/center selection: 0 – down 1 – center
	6:0	Pdiv6	01h	7-Bit Y6-Output-Divider Pdiv6: 0 – reset and stand-by 1-to-127 – divider value
37h	7	—	0b	Reserved – do not write others than 0
	6:0	Pdiv7	01h	7-Bit Y7-Output-Divider Pdiv7: 0 – reset and stand-by 1-to-127 – divider value
38h	7:0	PLL3_0N [11:4]	004h	PLL3_0 ⁽⁵⁾ : 30-Bit Multiplier/Divider value for frequency f_{VCO3_0} (for more information, see PLL Frequency Planning).
39h	7:4	PLL3_0N [3:0]		
	3:0	PLL3_0R [8:5]	000h	
3Ah	7:3	PLL3_0R[4:0]	10h	
	2:0	PLL3_0Q [5:3]		
3Bh	7:5	PLL3_0Q [2:0]	010b	
	4:2	PLL3_0P [2:0]		
	1:0	VCO3_0_RANGE	00b	
3Ch	7:0	PLL3_1N [11:4]	004h	PLL3_1 ⁽⁵⁾ : 30-Bit Multiplier/Divider value for frequency f_{VCO3_1} (for more information, see PLL Frequency Planning).
3Dh	7:4	PLL3_1N [3:0]		
	3:0	PLL3_1R [8:5]	000h	
3Eh	7:3	PLL3_1R[4:0]	10h	
	2:0	PLL3_1Q [5:3]		
3Fh	7:5	PLL3_1Q [2:0]	010b	
	4:2	PLL3_1P [2:0]		
	1:0	VCO3_1_RANGE	00b	

(5) PLL settings limits: $16 \leq q \leq 63$, $0 \leq p \leq 7$, $0 \leq r \leq 511$, $0 < N < 4096$

9 Application and Implementation

NOTE

Information in the following applications sections is not part of the TI component specification, and TI does not warrant its accuracy or completeness. TI's customers are responsible for determining suitability of components for their purposes. Customers should validate and test their design implementation to confirm system functionality.

9.1 Application Information

The CDCEx937 device is an easy-to-use, high-performance, programmable CMOS clock synthesizer. It can be used as a crystal buffer, clock synthesizer with separate output supply pin. The CDCEx937 features an on-chip loop filter and spread-spectrum modulation. Programming can be done through SPI, pin-mode, or using on-chip EEPROM. The following section shows some examples of using CDCEx937 in various applications.

9.2 Typical Application

Figure 14 shows the use of the CDCEx937 devices for replacement of crystals and crystal oscillators on a Gigabit Ethernet Switch application.

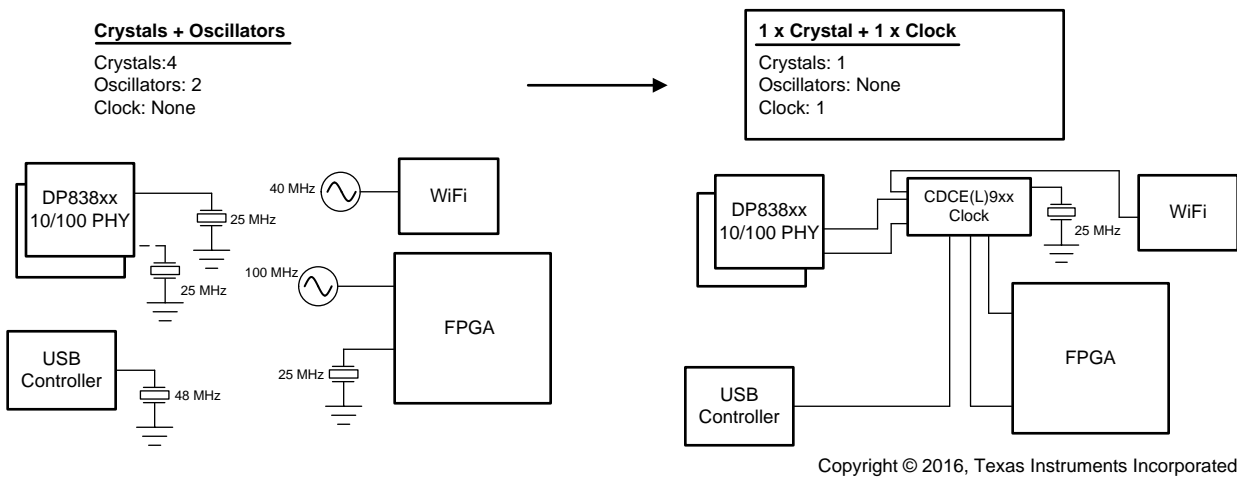

Figure 14. Crystal and Oscillator Replacement Example

9.2.1 Design Requirements

CDCEx937 supports spread-spectrum clocking (SSC) with multiple control parameters:

- Modulation amount (%)
- Modulation frequency (>20 kHz)
- Modulation shape (triangular)
- Center spread / down spread (\pm or $-$)

Typical Application (continued)

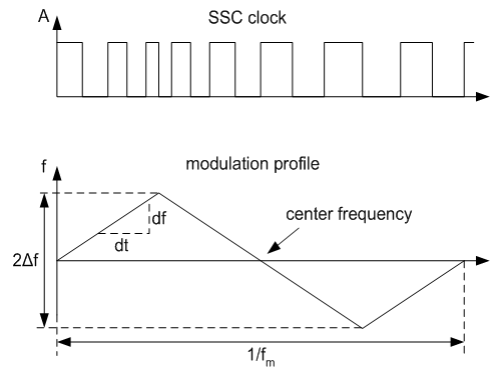
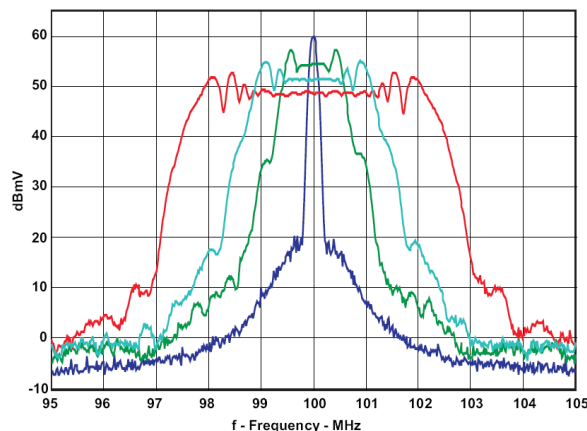

Figure 15. Modulation Frequency (f_m) and Modulation Amount

9.2.2 Detailed Design Procedure

9.2.2.1 Spread Spectrum Clock (SSC)

Spread-spectrum modulation is a method to spread emitted energy over a larger bandwidth. In clocking, spread spectrum can reduce Electromagnetic Interference (EMI) by reducing the level of emission from clock distribution network.



CDCS502 with a 25-MHz Crystal, FS = 1, f_{out} = 100 MHz, and 0%, ±0.5, ±1%, and ±2% SSC

Figure 16. Comparison Between Typical Clock Power Spectrum and Spread-Spectrum Clock

9.2.2.2 PLL Frequency Planning

At a given input frequency (f_{IN}), the output frequency (f_{OUT}) of the CDCE_x913 are calculated with Equation 1.

$$f_{OUT} = \frac{f_{IN}}{Pdiv} \times \frac{N}{M}$$

where

- M (1 to 511) and N (1 to 4095) are the multiplier/divide values of the PLL
- Pdiv (1 to 127) is the output divider

The target VCO frequency (f_{VCO}) of each PLL is calculated with Equation 2.

$$f_{VCO} = f_{IN} \times \frac{N}{M} \tag{2}$$

The PLL internally operates as fractional divider and needs the following multiplier/divider settings:

Typical Application (continued)

- N
- $P = 4 - \text{int}(\log_2 N/M)$; if $P < 0$ then $P = 0$
- $Q = \text{int}(N'/M)$
- $R = N' - M \times Q$

where

$$N' = N \times 2^P$$

$$N \geq M;$$

$$80 \text{ MHz} \leq f_{VCO} \leq 230 \text{ MHz}$$

$$16 \leq Q \leq 63$$

$$0 \leq P \leq 4$$

$$0 \leq R \leq 15$$

Example:

for $f_{IN} = 27 \text{ MHz}$; $M = 1$; $N = 4$; $P_{div} = 2$

- $f_{OUT} = 54 \text{ MHz}$
- $f_{VCO} = 108 \text{ MHz}$
- $P = 4 - \text{int}(\log_2 4) = 4 - 2 = 2$
- $N' = 4 \times 2^2 = 16$
- $Q = \text{int}(16) = 16$
- $R = 16 - 16 = 0$

for $f_{IN} = 27 \text{ MHz}$; $M = 2$; $N = 11$; $P_{div} = 2$

- $f_{OUT} = 74.25 \text{ MHz}$
- $f_{VCO} = 148.50 \text{ MHz}$
- $P = 4 - \text{int}(\log_2 5.5) = 4 - 2 = 2$
- $N' = 11 \times 2^2 = 44$
- $Q = \text{int}(22) = 22$
- $R = 44 - 44 = 0$

The values for P, Q, R, and N' are automatically calculated when using TI Pro-Clock™ software.

9.2.2.3 Crystal Oscillator Start-Up

When the CDCE937 is used as a crystal buffer, crystal oscillator start-up dominates the start-up time compared to the internal PLL lock time. Figure 17 shows the oscillator start-up sequence for a 27-MHz crystal input with an 8-pF load. The start-up time for the crystal is in the order of approximately 250 μs compared to approximately 10 μs of lock time. In general, lock time will be an order of magnitude less compared to the crystal start-up time.

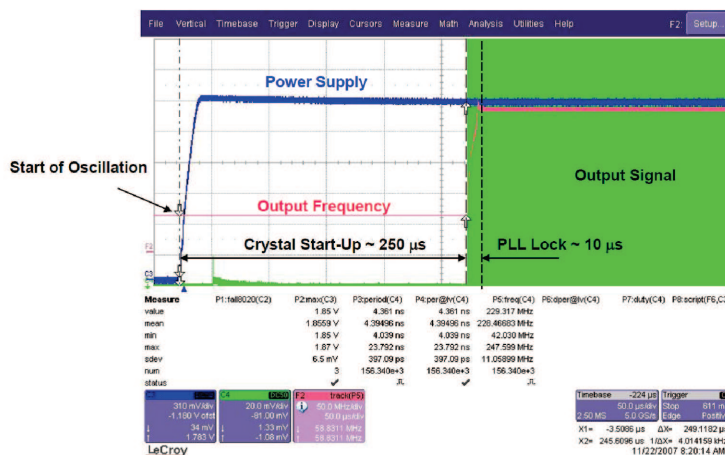
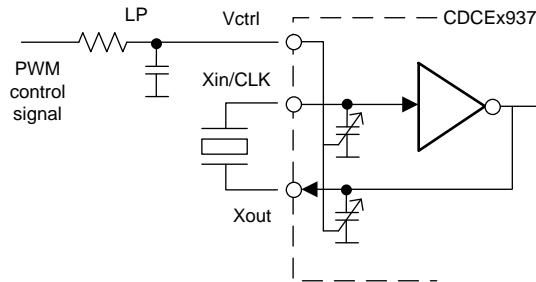

Figure 17. Crystal Oscillator Start-Up vs PLL Lock Time

9.2.2.4 Frequency Adjustment With Crystal Oscillator Pulling

The frequency for the CDCE937 is adjusted for media and other applications with the VCXO control input Vctrl. If a PWM modulated signal is used as a control signal for the VCXO, an external filter is needed.

Typical Application (continued)



Copyright © 2016, Texas Instruments Incorporated

Figure 18. Frequency Adjustment Using PWM Input to the VCXO Control

9.2.2.5 Unused Inputs and Outputs

If VCXO pulling functionality is not required, Vctrl should be left floating. All other unused inputs should be set to GND. Unused outputs should be left floating.

If one output block is not used, TI recommends disabling it. However, TI always recommends providing the supply for the second output block even if it is disabled.

9.2.2.6 Switching Between XO and VCXO Mode

When the CDCE937 is in crystal oscillator or in VCXO configuration, the internal capacitors require different internal capacitance. The following steps are recommended to switch to VCXO mode when the configuration for the on-chip capacitor is still set for XO mode. To center the output frequency to 0 ppm:

1. While in XO mode, put $Vctrl = Vdd / 2$
2. Switch from XO mode to VCXO mode
3. Program the internal capacitors in order to obtain 0 ppm at the output

9.2.3 Application Curves

Figure 19, Figure 20, Figure 21, and Figure 22 show CDCE937 measurements with the SSC feature enabled. Device configuration: 27-MHz input, 27-MHz output.

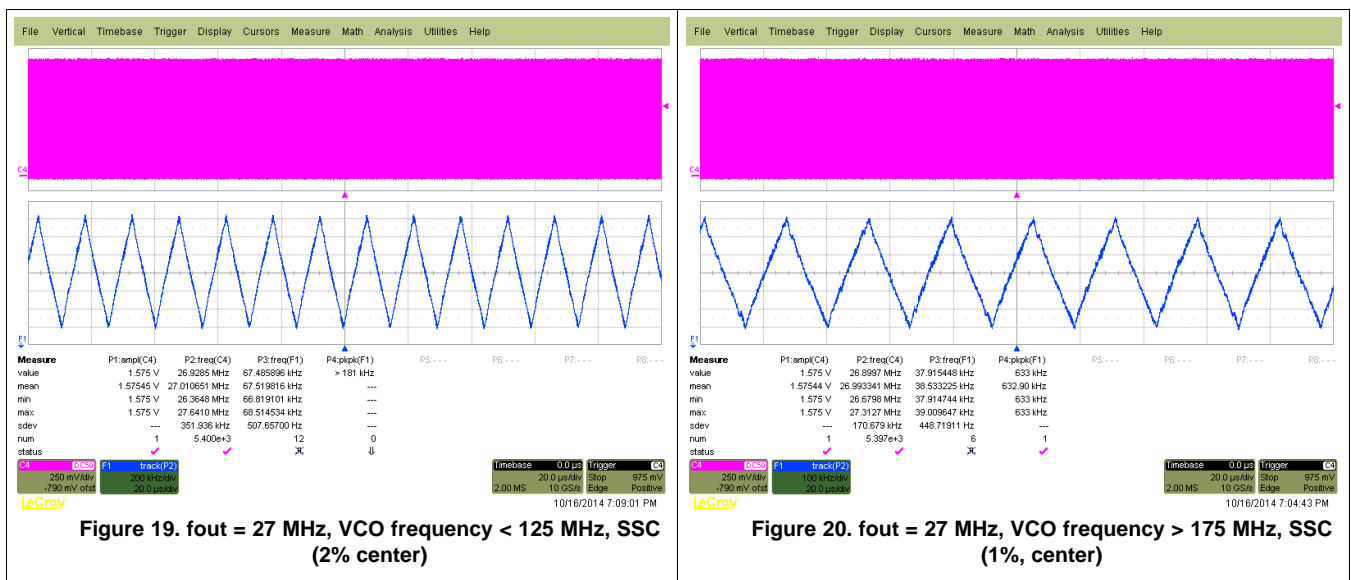

Typical Application (continued)

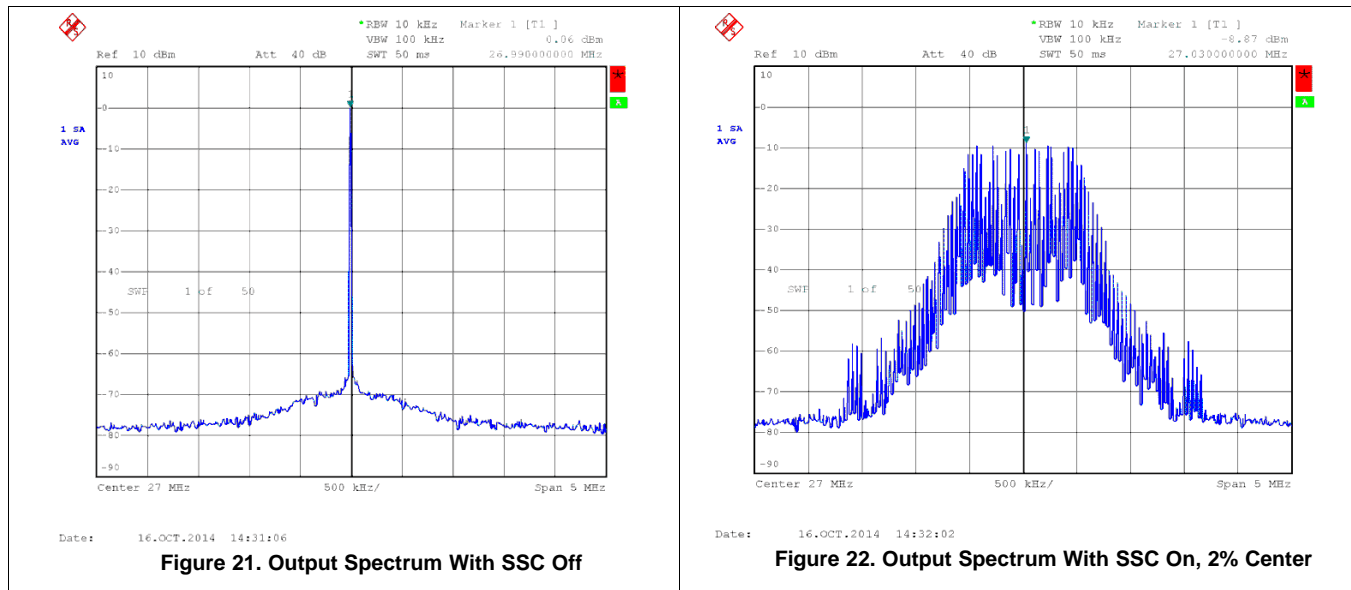

10 Power Supply Recommendations

There is no restriction on the power-up sequence. In case VDDOUT is applied first, TI recommends grounding VDD. In case VDDOUT is powered while VDD is floating, there is a risk of high current flowing on the VDDOUT.

The device has a power-up control that is connected to the 1.8-V supply. This keeps the whole device disabled until the 1.8-V supply reaches a sufficient voltage level. Then the device switches on all internal components, including the outputs. If there is a 3.3-V VDD available before the 1.8 V, the outputs remain disabled until the 1.8-V supply has reached a certain level.

11 Layout

11.1 Layout Guidelines

When the CDCE937 is used as a crystal buffer, any parasitics across the crystal affects the pulling range of the VCXO. Therefore, take care in placing the crystal units on the board. Crystals should be placed as close to the device as possible, ensuring that the routing lines from the crystal terminals to XIN and XOUT have the same length.

If possible, cut out both ground plane and power plane under the area where the crystal and the routing to the device are placed. In this area, always avoid routing any other signal line, as it could be a source of noise coupling.

Additional discrete capacitors can be required to meet the load capacitance specification of certain crystal. For example, a 10.7-pF load capacitor is not fully programmable on the chip, because the internal capacitor can range from 0 pF to 20 pF with steps of 1 pF. The 0.7-pF capacitor therefore can be discretely added on top of an internal 10 pF.

To minimize the inductive influence of the trace, TI recommends placing this small capacitor as close to the device as possible and symmetrically with respect to XIN and XOUT.

[Figure 23](#) shows a conceptual layout detailing recommended placement of power supply bypass capacitors on the basis of CDCE937. For component side mounting, use 0402 body size capacitors to facilitate signal routing. Keep the connections between the bypass capacitors and the power supply on the device as short as possible. Ground the other side of the capacitor using a low-impedance connection to the ground plane.

11.2 Layout Example

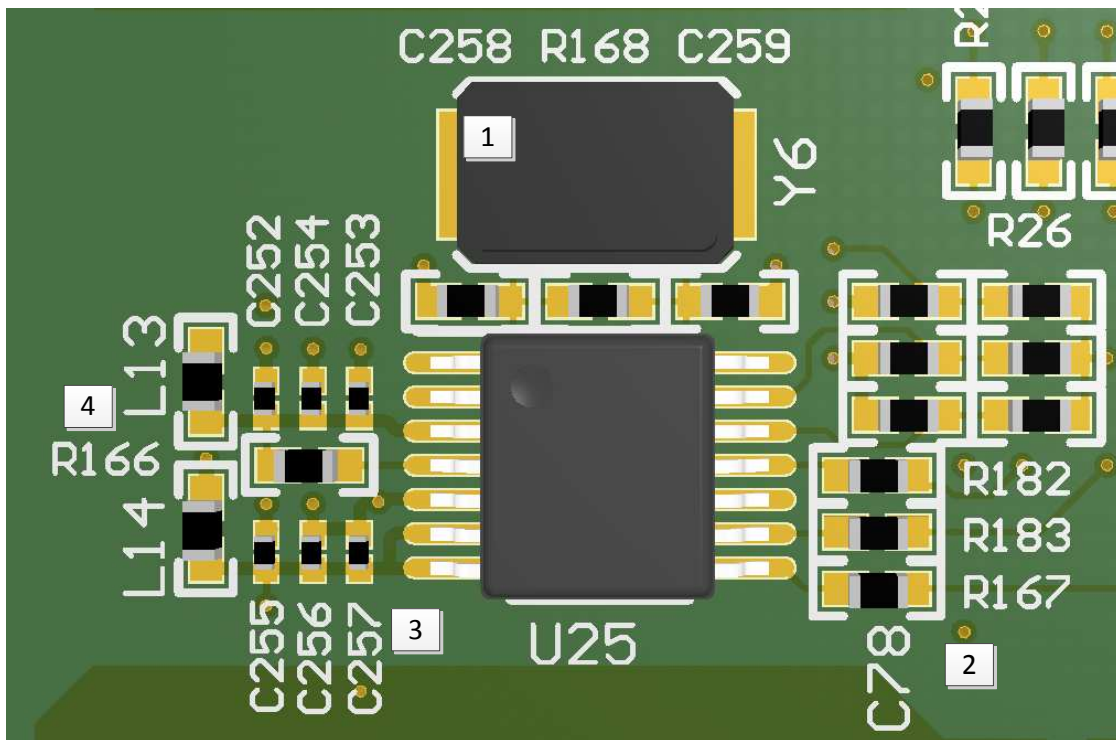

- | | |
|--|--|
| <p>1 Place crystal with associated load caps as close to the chip</p> | <p>2 Place series termination resistors at Clock outputs to improve signal integrity</p> |
| <p>3 Place bypass caps close to the device pins, ensure wide freq. range</p> | <p>4 Use ferrite beads to isolate the device supply pins from board noise sources</p> |

Figure 23. Annotated Layout

12 Device and Documentation Support

12.1 Device Support

12.1.1 Third-Party Products Disclaimer

TI'S PUBLICATION OF INFORMATION REGARDING THIRD-PARTY PRODUCTS OR SERVICES DOES NOT CONSTITUTE AN ENDORSEMENT REGARDING THE SUITABILITY OF SUCH PRODUCTS OR SERVICES OR A WARRANTY, REPRESENTATION OR ENDORSEMENT OF SUCH PRODUCTS OR SERVICES, EITHER ALONE OR IN COMBINATION WITH ANY TI PRODUCT OR SERVICE.

12.1.2 Development Support

For development support see the following:

- [SMBus](#)
- [I²C Bus](#)

12.2 Documentation Support

12.2.1 Related Documentation

For related documentation see the following:

[VCXO Application Guideline for CDCE\(L\)9xx Family](#) (SCAA085)

12.3 Receiving Notification of Documentation Updates

To receive notification of documentation updates, navigate to the device product folder on ti.com. In the upper right corner, click on *Alert me* to register and receive a weekly digest of any product information that has changed. For change details, review the revision history included in any revised document.

12.4 Community Resources

The following links connect to TI community resources. Linked contents are provided "AS IS" by the respective contributors. They do not constitute TI specifications and do not necessarily reflect TI's views; see TI's [Terms of Use](#).

TI E2E™ Online Community *TI's Engineer-to-Engineer (E2E) Community*. Created to foster collaboration among engineers. At e2e.ti.com, you can ask questions, share knowledge, explore ideas and help solve problems with fellow engineers.

Design Support *TI's Design Support* Quickly find helpful E2E forums along with design support tools and contact information for technical support.

12.5 Trademarks

TI-DaVinci, OMAP, Pro-Clock, E2E are trademarks of Texas Instruments.

Bluetooth is a trademark of Bluetooth SIG.

Ethernet is a trademark of Xerox Corporation.

All other trademarks are the property of their respective owners.

12.6 Electrostatic Discharge Caution



These devices have limited built-in ESD protection. The leads should be shorted together or the device placed in conductive foam during storage or handling to prevent electrostatic damage to the MOS gates.

12.7 Glossary

[SLYZ022](#) — *TI Glossary*.

This glossary lists and explains terms, acronyms, and definitions.

13 Mechanical, Packaging, and Orderable Information

The following pages include mechanical, packaging, and orderable information. This information is the most current data available for the designated devices. This data is subject to change without notice and revision of this document. For browser-based versions of this data sheet, refer to the left-hand navigation.

PACKAGING INFORMATION

Orderable Device	Status (1)	Package Type	Package Drawing	Pins	Package Qty	Eco Plan (2)	Lead/Ball Finish (6)	MSL Peak Temp (3)	Op Temp (°C)	Device Marking (4/5)	Samples
CDCE937PW	ACTIVE	TSSOP	PW	20	70	Green (RoHS & no Sb/Br)	CU NIPDAU	Level-1-260C-UNLIM	-40 to 85	CDCE937	Samples
CDCE937PWG4	ACTIVE	TSSOP	PW	20	70	Green (RoHS & no Sb/Br)	CU NIPDAU	Level-1-260C-UNLIM	-40 to 85	CDCE937	Samples
CDCE937PWR	ACTIVE	TSSOP	PW	20	2000	Green (RoHS & no Sb/Br)	CU NIPDAU	Level-1-260C-UNLIM	-40 to 85	CDCE937	Samples
CDCE937PWRG4	ACTIVE	TSSOP	PW	20	2000	Green (RoHS & no Sb/Br)	CU NIPDAU	Level-1-260C-UNLIM	-40 to 85	CDCE937	Samples
CDCEL937PW	ACTIVE	TSSOP	PW	20	70	Green (RoHS & no Sb/Br)	CU NIPDAU	Level-1-260C-UNLIM	-40 to 85	CDCEL937	Samples
CDCEL937PWR	ACTIVE	TSSOP	PW	20	2000	Green (RoHS & no Sb/Br)	CU NIPDAU	Level-1-260C-UNLIM	-40 to 85	CDCEL937	Samples
CDCEL937PWRG4	ACTIVE	TSSOP	PW	20	2000	Green (RoHS & no Sb/Br)	CU NIPDAU	Level-1-260C-UNLIM	-40 to 85	CDCEL937	Samples
HPA00406PWR	ACTIVE	TSSOP	PW	20	2000	Green (RoHS & no Sb/Br)	CU NIPDAU	Level-1-260C-UNLIM	-40 to 85	CDCE937	Samples

(1) The marketing status values are defined as follows:

ACTIVE: Product device recommended for new designs.

LIFEBUY: TI has announced that the device will be discontinued, and a lifetime-buy period is in effect.

NRND: Not recommended for new designs. Device is in production to support existing customers, but TI does not recommend using this part in a new design.

PREVIEW: Device has been announced but is not in production. Samples may or may not be available.

OBsolete: TI has discontinued the production of the device.

(2) **RoHS:** TI defines "RoHS" to mean semiconductor products that are compliant with the current EU RoHS requirements for all 10 RoHS substances, including the requirement that RoHS substance do not exceed 0.1% by weight in homogeneous materials. Where designed to be soldered at high temperatures, "RoHS" products are suitable for use in specified lead-free processes. TI may reference these types of products as "Pb-Free".

RoHS Exempt: TI defines "RoHS Exempt" to mean products that contain lead but are compliant with EU RoHS pursuant to a specific EU RoHS exemption.

Green: TI defines "Green" to mean the content of Chlorine (Cl) and Bromine (Br) based flame retardants meet JS709B low halogen requirements of <=100ppm threshold. Antimony trioxide based flame retardants must also meet the <=1000ppm threshold requirement.

(3) MSL, Peak Temp. - The Moisture Sensitivity Level rating according to the JEDEC industry standard classifications, and peak solder temperature.

(4) There may be additional marking, which relates to the logo, the lot trace code information, or the environmental category on the device.

(5) Multiple Device Markings will be inside parentheses. Only one Device Marking contained in parentheses and separated by a "-" will appear on a device. If a line is indented then it is a continuation of the previous line and the two combined represent the entire Device Marking for that device.

(6) Lead/Ball Finish - Orderable Devices may have multiple material finish options. Finish options are separated by a vertical ruled line. Lead/Ball Finish values may wrap to two lines if the finish value exceeds the maximum column width.

Important Information and Disclaimer:The information provided on this page represents TI's knowledge and belief as of the date that it is provided. TI bases its knowledge and belief on information provided by third parties, and makes no representation or warranty as to the accuracy of such information. Efforts are underway to better integrate information from third parties. TI has taken and continues to take reasonable steps to provide representative and accurate information but may not have conducted destructive testing or chemical analysis on incoming materials and chemicals. TI and TI suppliers consider certain information to be proprietary, and thus CAS numbers and other limited information may not be available for release.

In no event shall TI's liability arising out of such information exceed the total purchase price of the TI part(s) at issue in this document sold by TI to Customer on an annual basis.

OTHER QUALIFIED VERSIONS OF CDCE937, CDCEL937 :

- Automotive: [CDCE937-Q1](#), [CDCEL937-Q1](#)

NOTE: Qualified Version Definitions:

- Automotive - Q100 devices qualified for high-reliability automotive applications targeting zero defects

TAPE AND REEL INFORMATION

REEL DIMENSIONS

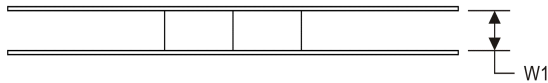
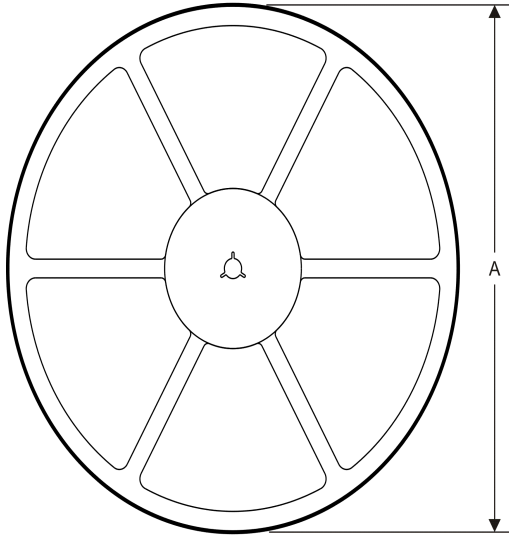

TAPE DIMENSIONS

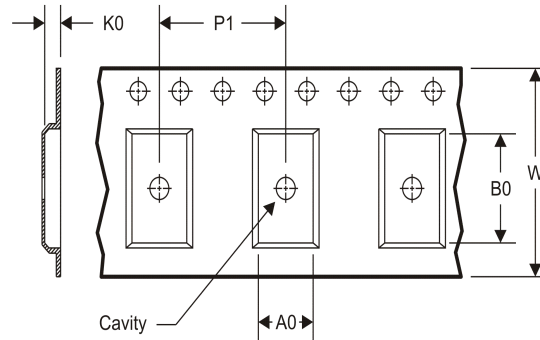

A0	Dimension designed to accommodate the component width
B0	Dimension designed to accommodate the component length
K0	Dimension designed to accommodate the component thickness
W	Overall width of the carrier tape
P1	Pitch between successive cavity centers

TAPE AND REEL INFORMATION

*All dimensions are nominal

Device	Package Type	Package Drawing	Pins	SPQ	Reel Diameter (mm)	Reel Width W1 (mm)	A0 (mm)	B0 (mm)	K0 (mm)	P1 (mm)	W (mm)	Pin1 Quadrant
CDCE937PWR	TSSOP	PW	20	2000	330.0	16.4	6.95	7.1	1.6	8.0	16.0	Q1
CDCEL937PWR	TSSOP	PW	20	2000	330.0	16.4	6.95	7.1	1.6	8.0	16.0	Q1

TAPE AND REEL BOX DIMENSIONS

*All dimensions are nominal

Device	Package Type	Package Drawing	Pins	SPQ	Length (mm)	Width (mm)	Height (mm)
CDCE937PWR	TSSOP	PW	20	2000	367.0	367.0	38.0
CDCEL937PWR	TSSOP	PW	20	2000	367.0	367.0	38.0

PW (R-PDSO-G20)

PLASTIC SMALL OUTLINE

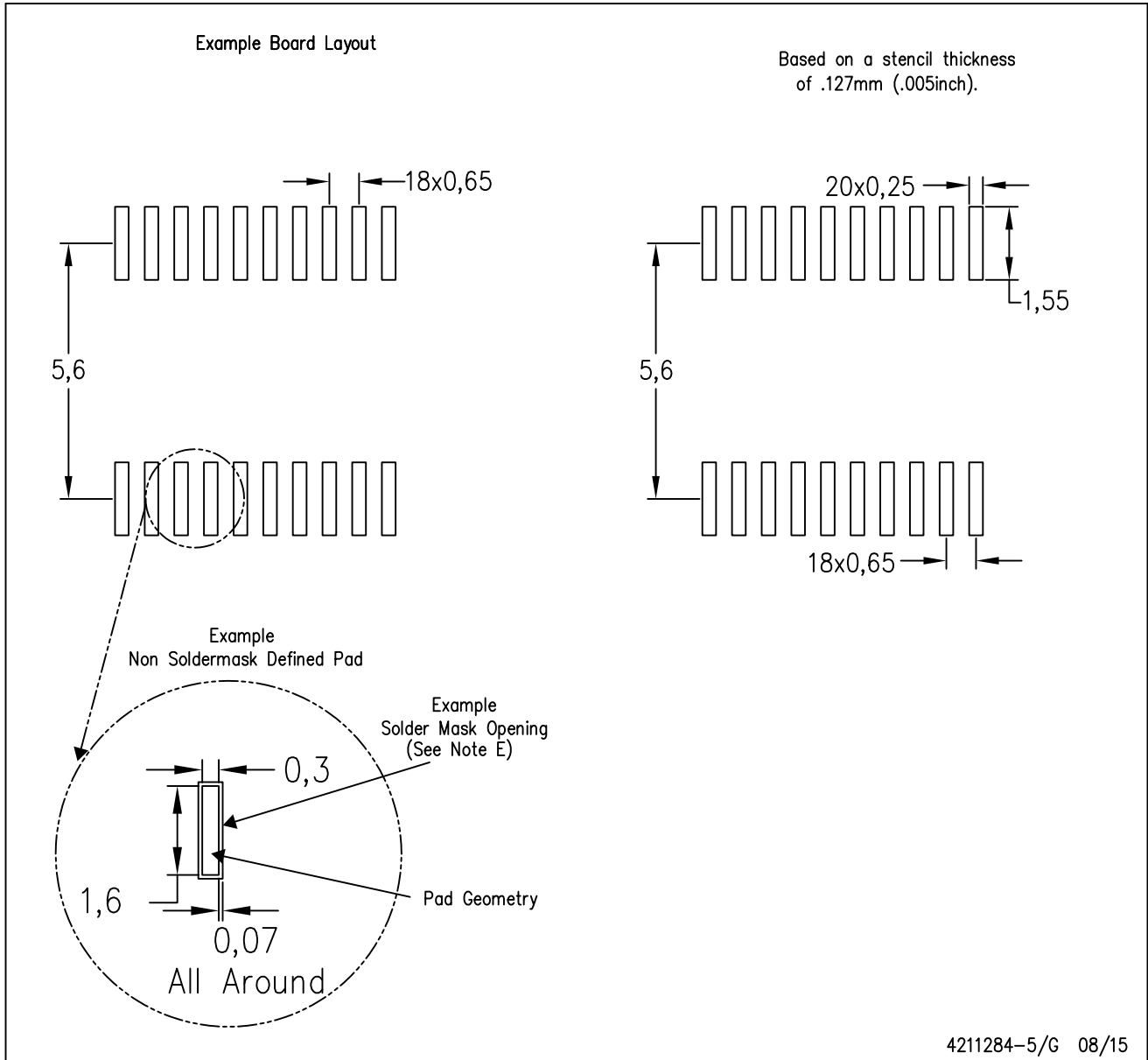

- NOTES:
- A. All linear dimensions are in millimeters.
 - B. This drawing is subject to change without notice.
 - C. Publication IPC-7351 is recommended for alternate design.
 - D. Laser cutting apertures with trapezoidal walls and also rounding corners will offer better paste release. Customers should contact their board assembly site for stencil design recommendations. Refer to IPC-7525 for other stencil recommendations.
 - E. Customers should contact their board fabrication site for solder mask tolerances between and around signal pads.

IMPORTANT NOTICE

Texas Instruments Incorporated (TI) reserves the right to make corrections, enhancements, improvements and other changes to its semiconductor products and services per JESD46, latest issue, and to discontinue any product or service per JESD48, latest issue. Buyers should obtain the latest relevant information before placing orders and should verify that such information is current and complete.

TI's published terms of sale for semiconductor products (<http://www.ti.com/sc/docs/stdterms.htm>) apply to the sale of packaged integrated circuit products that TI has qualified and released to market. Additional terms may apply to the use or sale of other types of TI products and services.

Reproduction of significant portions of TI information in TI data sheets is permissible only if reproduction is without alteration and is accompanied by all associated warranties, conditions, limitations, and notices. TI is not responsible or liable for such reproduced documentation. Information of third parties may be subject to additional restrictions. Resale of TI products or services with statements different from or beyond the parameters stated by TI for that product or service voids all express and any implied warranties for the associated TI product or service and is an unfair and deceptive business practice. TI is not responsible or liable for any such statements.

Buyers and others who are developing systems that incorporate TI products (collectively, "Designers") understand and agree that Designers remain responsible for using their independent analysis, evaluation and judgment in designing their applications and that Designers have full and exclusive responsibility to assure the safety of Designers' applications and compliance of their applications (and of all TI products used in or for Designers' applications) with all applicable regulations, laws and other applicable requirements. Designer represents that, with respect to their applications, Designer has all the necessary expertise to create and implement safeguards that (1) anticipate dangerous consequences of failures, (2) monitor failures and their consequences, and (3) lessen the likelihood of failures that might cause harm and take appropriate actions. Designer agrees that prior to using or distributing any applications that include TI products, Designer will thoroughly test such applications and the functionality of such TI products as used in such applications.

TI's provision of technical, application or other design advice, quality characterization, reliability data or other services or information, including, but not limited to, reference designs and materials relating to evaluation modules, (collectively, "TI Resources") are intended to assist designers who are developing applications that incorporate TI products; by downloading, accessing or using TI Resources in any way, Designer (individually or, if Designer is acting on behalf of a company, Designer's company) agrees to use any particular TI Resource solely for this purpose and subject to the terms of this Notice.

TI's provision of TI Resources does not expand or otherwise alter TI's applicable published warranties or warranty disclaimers for TI products, and no additional obligations or liabilities arise from TI providing such TI Resources. TI reserves the right to make corrections, enhancements, improvements and other changes to its TI Resources. TI has not conducted any testing other than that specifically described in the published documentation for a particular TI Resource.

Designer is authorized to use, copy and modify any individual TI Resource only in connection with the development of applications that include the TI product(s) identified in such TI Resource. NO OTHER LICENSE, EXPRESS OR IMPLIED, BY ESTOPPEL OR OTHERWISE TO ANY OTHER TI INTELLECTUAL PROPERTY RIGHT, AND NO LICENSE TO ANY TECHNOLOGY OR INTELLECTUAL PROPERTY RIGHT OF TI OR ANY THIRD PARTY IS GRANTED HEREIN, including but not limited to any patent right, copyright, mask work right, or other intellectual property right relating to any combination, machine, or process in which TI products or services are used. Information regarding or referencing third-party products or services does not constitute a license to use such products or services, or a warranty or endorsement thereof. Use of TI Resources may require a license from a third party under the patents or other intellectual property of the third party, or a license from TI under the patents or other intellectual property of TI.

TI RESOURCES ARE PROVIDED "AS IS" AND WITH ALL FAULTS. TI DISCLAIMS ALL OTHER WARRANTIES OR REPRESENTATIONS, EXPRESS OR IMPLIED, REGARDING RESOURCES OR USE THEREOF, INCLUDING BUT NOT LIMITED TO ACCURACY OR COMPLETENESS, TITLE, ANY EPIDEMIC FAILURE WARRANTY AND ANY IMPLIED WARRANTIES OF MERCHANTABILITY, FITNESS FOR A PARTICULAR PURPOSE, AND NON-INFRINGEMENT OF ANY THIRD PARTY INTELLECTUAL PROPERTY RIGHTS. TI SHALL NOT BE LIABLE FOR AND SHALL NOT DEFEND OR INDEMNIFY DESIGNER AGAINST ANY CLAIM, INCLUDING BUT NOT LIMITED TO ANY INFRINGEMENT CLAIM THAT RELATES TO OR IS BASED ON ANY COMBINATION OF PRODUCTS EVEN IF DESCRIBED IN TI RESOURCES OR OTHERWISE. IN NO EVENT SHALL TI BE LIABLE FOR ANY ACTUAL, DIRECT, SPECIAL, COLLATERAL, INDIRECT, PUNITIVE, INCIDENTAL, CONSEQUENTIAL OR EXEMPLARY DAMAGES IN CONNECTION WITH OR ARISING OUT OF TI RESOURCES OR USE THEREOF, AND REGARDLESS OF WHETHER TI HAS BEEN ADVISED OF THE POSSIBILITY OF SUCH DAMAGES.

Unless TI has explicitly designated an individual product as meeting the requirements of a particular industry standard (e.g., ISO/TS 16949 and ISO 26262), TI is not responsible for any failure to meet such industry standard requirements.

Where TI specifically promotes products as facilitating functional safety or as compliant with industry functional safety standards, such products are intended to help enable customers to design and create their own applications that meet applicable functional safety standards and requirements. Using products in an application does not by itself establish any safety features in the application. Designers must ensure compliance with safety-related requirements and standards applicable to their applications. Designer may not use any TI products in life-critical medical equipment unless authorized officers of the parties have executed a special contract specifically governing such use. Life-critical medical equipment is medical equipment where failure of such equipment would cause serious bodily injury or death (e.g., life support, pacemakers, defibrillators, heart pumps, neurostimulators, and implantables). Such equipment includes, without limitation, all medical devices identified by the U.S. Food and Drug Administration as Class III devices and equivalent classifications outside the U.S.

TI may expressly designate certain products as completing a particular qualification (e.g., Q100, Military Grade, or Enhanced Product). Designers agree that it has the necessary expertise to select the product with the appropriate qualification designation for their applications and that proper product selection is at Designers' own risk. Designers are solely responsible for compliance with all legal and regulatory requirements in connection with such selection.

Designer will fully indemnify TI and its representatives against any damages, costs, losses, and/or liabilities arising out of Designer's non-compliance with the terms and provisions of this Notice.

Looking for pricing, stock, or lifecycle information?

Click below to explore more details on WIN SOURCE:

 [View CDCE937PW](#) on WIN SOURCE

 [Texas Instruments](#) Information

Optimize Your Supply Chain with WIN SOURCE Solutions

-  Global Sourcing Solution
-  Obsolete Management
-  Cost Control Management
-  Shortage Management
-  Alternative Solution
-  Excess Inventory Management