



THE DATASHEET OF CDCE949PWR



CDCE(L)949: Flexible Low Power LVC MOS Clock Generator

With SSC Support for EMI Reduction

1 Features

- Member of programmable clock generator family
 - CDCEx913: 1 PLLs, 3 outputs
 - CDCEx925: 2 PLLs, 5 outputs
 - CDCEx937: 3 PLLs, 7 outputs
 - *CDCEx949: 4 PLLs, 9 outputs*
- In-System programmability and EEPROM
 - Serial programmable volatile register
 - Nonvolatile EEPROM to store customer settings
- Flexible input clocking concept
 - External crystal: 8MHz to 32MHz
 - On-chip VCXO pull-range: ± 150 ppm
 - Single-ended LVC MOS up to 160MHz
- Free selectable output frequency up to 230MHz
- Low-noise PLL core
 - PLL loop filter components integrated
 - Low period jitter: 60ps (typical)
- Separate output supply pins
 - CDCE949: 3.3V and 2.5V
 - CDCEL949: 1.8V
- Flexible clock driver
 - Three user-definable control inputs [S0/S1/S2] (for example: SSC selection, frequency switching, output enable or power down)
 - Generates highly accurate clocks for video, audio, USB, IEEE1394, RFID, Bluetooth®, WLAN, Ethernet™, and GPS
 - Generates common clock frequencies used with TI-DaVinci™, OMAP™, DSPs
 - Programmable SSC modulation
 - Enables 0ppm clock generation
- 1.8V device core supply
- Wide temperature range: -40°C to 85°C
- Packaged in TSSOP
- Development and programming kit for easy PLL design and programming (TI Pro-Clock™)

2 Applications

- D-TVs
- STBs
- IP-STBs
- DVD players
- DVD recorders
- Printers

3 Description

The CDCE949 and CDCEL949 are modular PLL-based low cost, high-performance, programmable clock synthesizers, multipliers and dividers. These devices generate up to nine output clocks from a single input frequency. Each output can be programmed in-system for any clock frequency up to 230MHz, using up to four independent configurable PLLs.

The CDCEx949 has separate output supply pins (V_{DDOUT}): 1.8V for the CDCEL949 and 2.5V to 3.3V for the CDCE949.

The input accepts an external crystal or LVC MOS clock signal. If an external crystal is used, an on-chip load capacitor is adequate for most applications. The value of the load capacitor is programmable from 0pF to 20pF. Additionally, an on-chip VCXO is selectable, allowing synchronization of the output frequency to an external control signal, that is, a PWM signal.

The deep M/N divider ratio allows the generation of 0ppm audio or video, networking (WLAN, Bluetooth™, Ethernet, GPS) or Interface (USB, IEEE1394, Memory Stick) clocks from a reference input frequency, such as 27MHz.

All PLLs support SSC (Spread-Spectrum Clocking). SSC can be Center-Spread or Down-Spread clocking. This is a common technique to reduce electromagnetic interference (EMI).

Based on the PLL frequency and the divider settings, the internal loop-filter components are automatically adjusted to achieve high stability, and to optimize the jitter-transfer characteristics of each PLL.

Package Information

PART NUMBER	PACKAGE ⁽¹⁾	PACKAGE SIZE ⁽²⁾
CDCE949	PW (TSSOP, 24)	7.8mm × 6.4mm
CDCEL949		

(1) For all available packages, see [Section 12](#).

(2) The package size (length × width) is a nominal value and includes pins, where applicable.



The device supports non-volatile EEPROM programming for easy customization of the device to the application. The CDCE949 is preset to a factory-default configuration. The device can be reprogrammed to a different application configuration before PCB assembly, or reprogrammed by in-system programming. All device settings are programmable through the SDA and SCL bus, a 2-wire serial interface.

Three programmable control inputs, S0, S1 and S2, can be used to control various aspects of operation including frequency selection, changing the SSC parameters to lower EMI, PLL bypass, power down, and choosing between low level or 3-state for the output-disable function.

The CDCE949 operates in a 1.8V environment within a temperature range of -40°C to 85°C .

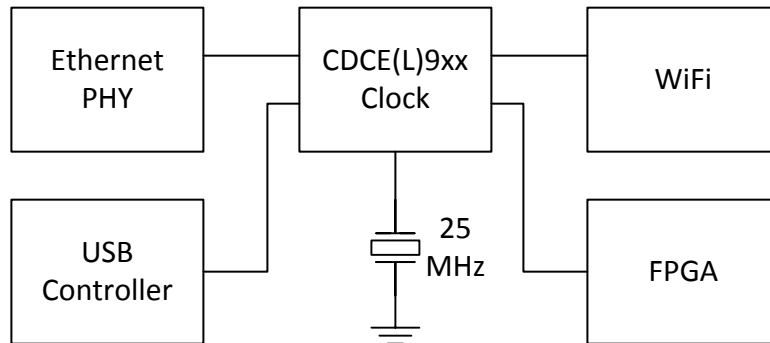

Copyright © 2016, Texas Instruments Incorporated

Typical Application Schematic

Table of Contents

1 Features	1	7.5 Programming.....	17
2 Applications	1	8 Application and Implementation	19
3 Description	1	8.1 Application Information.....	19
4 Pin Configuration and Functions	4	8.2 Typical Application.....	19
5 Specifications	5	8.3 Power Supply Recommendations.....	23
5.1 Absolute Maximum Ratings.....	5	8.4 Layout.....	23
5.2 ESD Ratings.....	5	9 Register Maps	25
5.3 Recommended Operating Conditions.....	5	9.1 SDA/SCL Configuration Registers.....	25
5.4 Thermal Information.....	6	10 Device and Documentation Support	33
5.5 Electrical Characteristics.....	6	10.1 Device Support.....	33
5.6 EEPROM Specification.....	8	10.2 Related Documentation.....	33
5.7 Timing Requirements: CLK_IN.....	8	10.3 Related Links.....	33
5.8 Timing Requirements: SDA/SCL.....	8	10.4 Receiving Notification of Documentation Updates..	33
5.9 Typical Characteristics.....	10	10.5 Support Resources.....	33
6 Parameter Measurement Information	11	10.6 Trademarks.....	33
7 Detailed Description	12	10.7 Electrostatic Discharge Caution.....	33
7.1 Overview.....	12	10.8 Glossary.....	33
7.2 Functional Block Diagram.....	13	11 Revision History	33
7.3 Feature Description.....	13	12 Mechanical, Packaging, and Orderable	
7.4 Device Functional Modes.....	16	Information	35

4 Pin Configuration and Functions

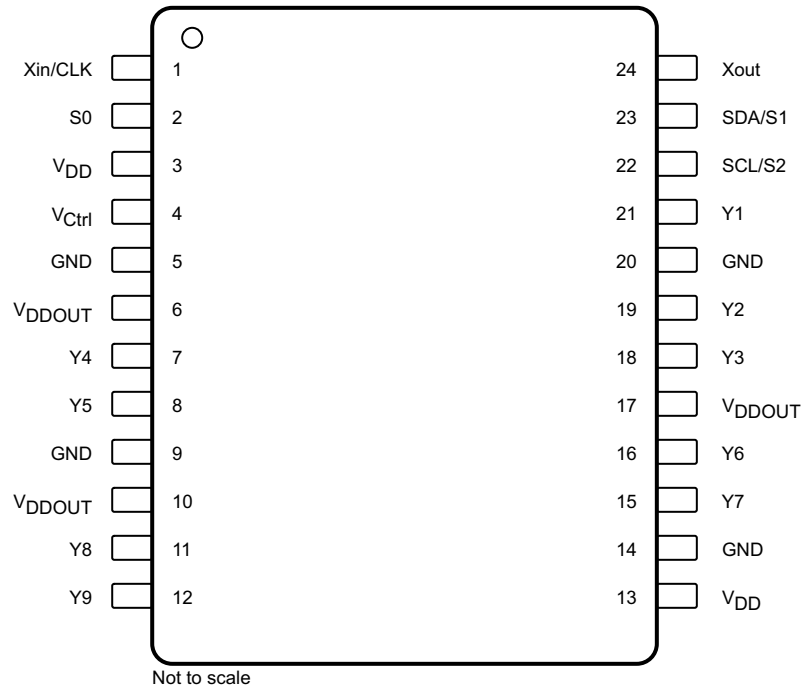

Figure 4-1. PW Package 24-Pin TSSOP (Top View)

Table 4-1. Pin Functions

PIN		TYPE ⁽¹⁾	DESCRIPTION
NAME	NO.		
GND	5, 9, 14, 20	G	Ground
SCL/S2	22	I	SCL : Serial clock input (default configuration), LVCMOS; internal pullup 500 kΩ; or S2 : User-programmable control input; LVCMOS inputs; internal pullup 500 kΩ
SDA/S1	23	I/O	SDA : Bidirectional serial data input/output (default configuration), LVCMOS; internal pullup 500 kΩ; or S1 : User-programmable control input; LVCMOS inputs; internal pullup 500 kΩ
S0	2	I	User-programmable control input S0; LVCMOS inputs; internal pullup 500 kΩ
V _{Ctrl}	4	I	VCXO control voltage (leave open or pull up when not used)
V _{DD}	3, 13	P	1.8-V power supply for the device
V _{DDOUT}	6, 10, 17	P	CDCEL949 : 1.8-V supply for all outputs CDCE949 : 3.3-V or 2.5-V supply for all outputs
Xin/CLK	1	I	Crystal oscillator input or LVCMOS clock input (selectable through SDA/SCL bus)
Xout	24	O	Crystal oscillator output (leave open or pull up when not used)
Y1	21	O	LVCMOS output
Y2	19		
Y3	18		
Y4	7		
Y5	8		
Y6	16		
Y7	15		
Y8	11		
Y9	12		

(1) G = Ground, I = Input, O = Output, P = Power

5 Specifications

5.1 Absolute Maximum Ratings

over operating free-air temperature range (unless otherwise noted)⁽¹⁾

		MIN	MAX	UNIT
V _{DD}	Supply voltage	-0.5	2.5	V
V _I	Input voltage ^{(2) (3)}	-0.5	V _{DD} + 0.5	V
V _O	Output voltage ⁽²⁾	-0.5	V _{DDOUT} + 0.5	V
I _I	Input current (V _I < 0, V _I > V _{DD})		20	mA
I _O	Continuous output current		50	mA
T _J	Junction temperature		125	°C
T _{stg}	Storage temperature	-65	150	°C

- (1) Stresses beyond those listed under *Absolute Maximum Ratings* may cause permanent damage to the device. These are stress ratings only and functional operation of the device at these or any other conditions beyond those indicated under *Recommended Operating Conditions* is not implied. Exposure to absolute–maximum–rated conditions for extended periods may affect device reliability.
- (2) The input and output negative voltage ratings may be exceeded if the input and output clamp–current ratings are observed.
- (3) SDA and SCL can go up to 3.6 V as stated in the *Recommended Operating Conditions* table.

5.2 ESD Ratings

		VALUE	UNIT
V _(ESD)	Electrostatic discharge	Human-body model (HBM), per ANSI/ESDA/JEDEC JS-001 ⁽¹⁾	±2000
		Charged-device model (CDM), per JEDEC specification JESD22-C101 ⁽²⁾	±1500

- (1) JEDEC document JEP155 states that 500-V HBM allows safe manufacturing with a standard ESD control process.
- (2) JEDEC document JEP157 states that 250-V CDM allows safe manufacturing with a standard ESD control process.

5.3 Recommended Operating Conditions

		MIN	NOM	MAX	UNIT
V _{DD}	Device supply voltage	1.7	1.8	1.9	V
V _{DD(OUT)}	Output Yx supply voltage	CDCE949		3.6	V
		CDCEL949	1.7	1.9	
V _{IL}	Low level input voltage LVCMOS			0.3 × V _{DD}	V
V _{IH}	High level input voltage LVCMOS	0.7 × V _{DD}			V
V _{I(thresh)}	Input voltage threshold LVCMOS		0.5 × V _{DD}		V
V _{IS}	Input voltage	S0	0	1.9	V
		S1, S2, SDA, SCL, V _{Ithresh} = 0.5 × V _{DD}	0	3.6	
V _{ICLK}	Input voltage CLK	0		1.9	V
I _{OH} / I _{OL}	Output current	V _{DDout} = 3.3 V		±12	mA
		V _{DDout} = 2.5 V		±10	mA
		V _{DDout} = 1.8 V		±8	mA
C _L	Output load LVCMOS			10	pF
T _A	Operating free-air temperature	-40		85	°C
CRYSTAL AND VCXO⁽¹⁾					
f _{Xtal}	Crystal Input frequency (fundamental mode)	8	27	32	MHz
ESR	Effective series resistance			100	Ω
f _{PR}	Pulling (0 V ≤ V _{Ctrl} ≤ 1.8 V) ⁽²⁾	±120	±150		ppm
V _(Ctrl)	Frequency control voltage	0		V _{DD}	V
C ₀ /C ₁	Pullability ratio			220	

CDCE949, CDCEL949

SCAS844G – AUGUST 2007 – REVISED JANUARY 2024

		MIN	NOM	MAX	UNIT
C_L	On-chip load capacitance at Xin and Xout	0		20	pF

- For more information about VCXO configuration and crystal recommendation, see [VCXO Application Guideline for CDCE\(L\)9xx Family \(SCAA085\)](#).
- Pulling range depends on crystal type, on-chip crystal load capacitance and PCB stray capacitance; pulling range of min ± 120 ppm applies for crystal listed in [VCXO Application Guideline for CDCE\(L\)9xx Family \(SCAA085\)](#).

5.4 Thermal Information

THERMAL METRIC ⁽²⁾		CDCEx949	UNIT	
		PW (TSSOP)		
		24 PINS		
θ_{JA}	Junction-to-ambient thermal resistance ⁽¹⁾	Airflow 0 (LFM)	91	°C/W
		Airflow 150 (LFM)	75	
		Airflow 200 (LFM)	74	
		Airflow 250 (LFM)	73	
		Airflow 500 (LFM)	65	
θ_{JCTop}	Junction-to-case (top) thermal resistance	0.5	°C/W	
θ_{JB}	Junction-to-board thermal resistance	52	°C/W	
Ψ_{JT}	Junction-to-top characterization parameter	0.5	°C/W	
Ψ_{JB}	Junction-to-board characterization parameter	50.1	°C/W	
θ_{JCbot}	Junction-to-case (bottom) thermal resistance	50	°C/W	

- The package thermal impedance is calculated in accordance with JESD 51 and JEDEC2S2P (high-k board).
- For more information about traditional and new thermal metrics, see the [Semiconductor and IC Package Thermal Metrics](#) application report.

5.5 Electrical Characteristics

over recommended operating free-air temperature range (unless otherwise noted)

PARAMETER	TEST CONDITIONS	MIN	TYP ⁽¹⁾	MAX	UNIT
I_{DD}	Supply current (see Figure 5-1)	All outputs off, $f_{CLK} = 27$ MHz, $f_{VCO} = 135$ MHz	All PLLs on	38	mA
			Per PLL	9	
$I_{DD(OUT)}$	Supply current (see Figure 5-2 and Figure 5-3)	No load, all outputs on, $f_{out} = 27$ MHz	CDCE949 $V_{DDOUT} = 3.3$ V	4	mA
			CDCEL949 $V_{DDOUT} = 1.8$ V	2	
$I_{DD(PD)}$	Power down current	Every circuit powered down except SDA/SCL, $f_{IN} = 0$ MHz, $V_{DD} = 1.9$ V	50		μ A
$V_{(PUC)}$	Supply voltage V_{DD} threshold for power up control circuit	0.85		1.45	V
f_{VCO}	VCO frequency range of PLL	80		230	MHz
f_{OUT}	LVC MOS output frequency	230			MHz
LVC MOS					
V_{IK}	LVC MOS input voltage	$V_{DD} = 1.7$ V, $I_I = -18$ mA		-1.2	V
I_I	LVC MOS input current	$V_I = 0$ V or V_{DD} , $V_{DD} = 1.9$ V		± 5	μ A
I_{IH}	LVC MOS input current for S0/S1/S2	$V_I = V_{DD}$, $V_{DD} = 1.9$ V		5	μ A
I_{IL}	LVC MOS input current for S0/S1/S2	$V_I = 0$ V, $V_{DD} = 1.9$ V		-4	μ A

over recommended operating free-air temperature range (unless otherwise noted)

PARAMETER		TEST CONDITIONS	MIN	TYP ⁽¹⁾	MAX	UNIT
C _i	Input capacitance at Xin/Clk	V _{ICLK} = 0 V or V _{DD}		6		pF
	Input capacitance at Xout	V _{IXout} = 0 V or V _{DD}		2		
	Input capacitance at S0/S1/S2	V _{IS} = 0 V or V _{DD}		3		
CDCE949 – LVCMOS FOR V_{DDOUT} = 3.3 V						
V _{OH}	LVCMOS high-level output voltage	V _{DDOUT} = 3 V, I _{OH} = –0.1 mA	2.9			V
		V _{DDOUT} = 3 V, I _{OH} = –8 mA	2.4			
		V _{DDOUT} = 3 V, I _{OH} = –12 mA	2.2			
V _{OL}	LVCMOS low-level output voltage	V _{DDOUT} = 3 V, I _{OL} = 0.1 mA			0.1	V
		V _{DDOUT} = 3 V, I _{OL} = 8 mA			0.5	
		V _{DDOUT} = 3 V, I _{OL} = 12 mA			0.8	
t _{PLH} , t _{PHL}	Propagation delay	PLL bypass		3.2		ns
t _r /t _f	Rise and fall time	V _{DDOUT} = 3.3 V (20%–80%)		0.6		ns
t _{jitter(cc)}	Cycle-to-cycle jitter ^{(2) (3)}	1 PLL switching, Y2-to-Y3		60	90	ps
		4 PLLs switching, Y2-to-Y9		120	170	
t _{jitter(per)}	Peak-to-peak period jitter ^{(2) (3)}	1 PLL switching, Y2-to-Y3		70	100	ps
		4 PLLs switching, Y2-to-Y9		130	180	
t _{sk(o)}	Output skew ⁽⁴⁾	f _{OUT} = 50 MHz, Y1-to-Y3			60	ps
		f _{OUT} = 50 MHz, Y2-to-Y5 or Y6-to-Y9			160	
odc	Output duty cycle ⁽⁵⁾	f _{VCO} = 100 MHz, Pdiv = 1	45%		55%	
CDCE949 – LVCMOS FOR V_{DDOUT} = 2.5 V						
V _{OH}	LVCMOS high-level output voltage	V _{DDOUT} = 2.3 V, I _{OH} = –0.1 mA	2.2			V
		V _{DDOUT} = 2.3 V, I _{OH} = –6 mA	1.7			
		V _{DDOUT} = 2.3 V, I _{OH} = –10 mA	1.6			
V _{OL}	LVCMOS low-level output voltage	V _{DDOUT} = 2.3 V, I _{OL} = 0.1 mA			0.1	V
		V _{DDOUT} = 2.3 V, I _{OL} = 6 mA			0.5	
		V _{DDOUT} = 2.3 V, I _{OL} = 10 mA			0.7	
t _{PLH} , t _{PHL}	Propagation delay	PLL bypass		3.4		ns
t _r /t _f	Rise and fall time	V _{DDOUT} = 2.5 V (20%–80%)		0.8		ns
t _{jitter(cc)}	Cycle-to-cycle jitter ^{(2) (3)}	1 PLL switching, Y2-to-Y3		60	90	ps
		4 PLLs switching, Y2-to-Y9		120	170	
t _{jitter(per)}	Peak-to-peak period jitter ^{(2) (3)}	1 PLL switching, Y2-to-Y3		70	100	ps
		4 PLLs switching, Y2-to-Y9		130	180	
t _{sk(o)}	Output skew ⁽⁴⁾	f _{OUT} = 50 MHz, Y1-to-Y3			60	ps
		f _{OUT} = 50 MHz, Y2-to-Y5 or Y6-to-Y9			160	
odc	Output duty cycle ⁽⁵⁾	f _{VCO} = 100 MHz, Pdiv = 1	45%		55%	
CDCEL949 – LVCMOS FOR V_{DDOUT} = 1.8 V						
V _{OH}	LVCMOS high-level output voltage	V _{DDOUT} = 1.7 V, I _{OH} = –0.1 mA	1.6			V
		V _{DDOUT} = 1.7 V, I _{OH} = –4 mA	1.4			
		V _{DDOUT} = 1.7 V, I _{OH} = –8 mA	1.1			
V _{OL}	LVCMOS low-level output voltage	V _{DDOUT} = 1.7 V, I _{OL} = 0.1 mA			0.1	V
		V _{DDOUT} = 1.7 V, I _{OL} = 4 mA			0.3	
		V _{DDOUT} = 1.7 V, I _{OL} = 8 mA			0.6	

over recommended operating free-air temperature range (unless otherwise noted)

PARAMETER		TEST CONDITIONS	MIN	TYP ⁽¹⁾	MAX	UNIT
t_{PLH} , t_{PHL}	Propagation delay	PLL bypass		2.6		ns
t_r/t_f	Rise and fall time	$V_{DDOUT} = 1.8\text{ V}$ (20%–80%)		0.7		ns
$t_{jit(cc)}$	Cycle-to-cycle jitter ^{(2) (3)}	1 PLL switching, Y2-to-Y3		70	120	ps
		4 PLLs switching, Y2-to-Y9		120	170	
$t_{jit(per)}$	Peak-to-peak period jitter ^{(2) (3)}	1 PLL switching, Y2-to-Y3		90	140	ps
		4 PLLs switching, Y2-to-Y9		130	190	
$t_{sk(o)}$	Output skew ⁽⁴⁾	$f_{OUT} = 50\text{ MHz}$, Y1-to-Y3			60	ps
		$f_{OUT} = 50\text{ MHz}$, Y2-to-Y5 or Y6-to-Y9			160	
odc	Output duty cycle ⁽⁵⁾	$f_{VCO} = 100\text{ MHz}$, Pdiv = 1	45%		55%	

SDA AND SCL

V_{IK}	SCL and SDA input clamp voltage	$V_{DD} = 1.7\text{ V}$, $I_I = -18\text{ mA}$			-1.2	V
I_{IH}	SCL and SDA input current	$V_I = V_{DD}$, $V_{DD} = 1.9\text{ V}$			±10	µA
V_{IH}	SDA/SCL input high voltage ⁽⁶⁾		$0.7 \times V_{DD}$			V
V_{IL}	SDA/SCL input low voltage ⁽⁶⁾			$0.3 \times V_{DD}$		V
V_{OL}	SDA low-level output voltage	$I_{OL} = 3\text{ mA}$, $V_{DD} = 1.7\text{ V}$			$0.2 \times V_{DD}$	V
C_I	SCL/SDA input capacitance	$V_I = 0\text{ V}$ or V_{DD}		3	10	pF

(1) All typical values are at respective nominal V_{DD} .

(2) 10000 cycles.

(3) Jitter depends on device configuration. Data is taken under the following conditions: 1-PLL: $f_{IN} = 27\text{ MHz}$, Y2/3 = 27 MHz, (measured at Y2), 4-PLL: $f_{IN} = 27\text{ MHz}$, Y2/3 = 27 MHz, (measured at Y2), Y4/5 = 16.384 MHz, Y6/7 = 74.25 MHz, Y8/9 = 48 MHz.

(4) The $t_{sk(o)}$ specification is only valid for equal loading of each bank of outputs and outputs are generated from the same divider; data sampled on rising edge (t_r).

(5) odc depends on output rise- and fall-time (t_r/t_f).

(6) SDA and SCL pins are 3.3-V tolerant.

5.6 EEPROM Specification

		MIN	TYP	MAX	UNIT
EEcyc	Programming cycles of EEPROM	1000			cycles
EEret	Data retention	10			years

5.7 Timing Requirements: CLK_IN

		MIN	NOM	MAX	UNIT
f_{CLK}	LVCMOS clock input frequency	PLL bypass mode	0	160	MHz
		PLL mode	8	160	
t_r / t_f	Rise and fall time CLK signal (20% to 80%)			3	ns
duty _{CLK}	Duty cycle CLK at $V_{DD} / 2$	40%		60%	

5.8 Timing Requirements: SDA/SCL

over operating free-air temperature range (unless otherwise noted; see Figure 7-9)

		MIN	NOM	MAX	UNIT
f_{SCL}	SCL clock frequency	Standard mode	0	100	kHz
		Fast mode	0	400	
$t_{su(START)}$	START setup time (SCL high before SDA low)	Standard mode	4.7		µs
		Fast mode	0.6		

over operating free-air temperature range (unless otherwise noted; see [Figure 7-9](#))

			MIN	NOM	MAX	UNIT
$t_{h(\text{START})}$	START hold time (SCL low after SDA low)	Standard mode	4			μs
		Fast mode	0.6			
$t_{w(\text{SCLL})}$	SCL low-pulse duration	Standard mode	4.7			μs
		Fast mode	1.3			
$t_{w(\text{SCLH})}$	SCL high-pulse duration	Standard mode	4			μs
		Fast mode	0.6			
$t_{h(\text{SDA})}$	SDA hold time (SDA valid after SCL low)	Standard mode	0		3.45	μs
		Fast mode	0		0.9	
$t_{su(\text{SDA})}$	SDA setup time	Standard mode	250			ns
		Fast mode	100			
t_r	SCL/SDA input rise time	Standard mode			1000	ns
		Fast mode			300	
t_f	SCL/SDA input fall time			300	ns	
$t_{su(\text{STOP})}$	STOP setup time	Standard mode	4			μs
		Fast mode	0.6			
t_{BUF}	Bus free time between a STOP and START condition	Standard mode	4.7			μs
		Fast mode	1.3			

5.9 Typical Characteristics

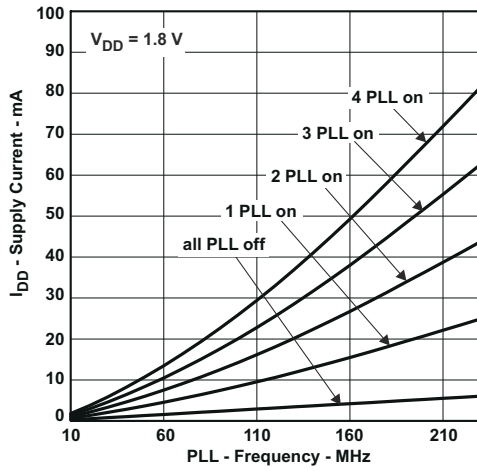

Figure 5-1. CDCE949 Supply Current vs PLL Frequency

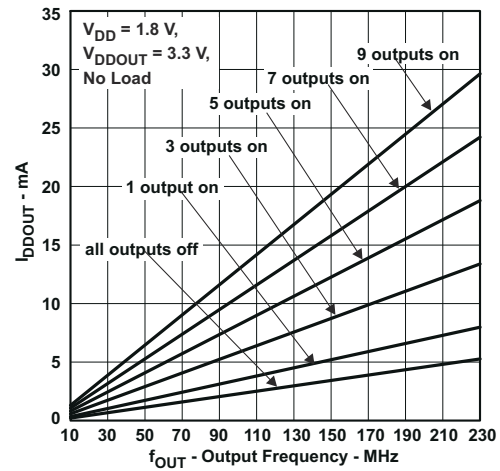

Figure 5-2. CDCE949 Output Current vs Output Frequency

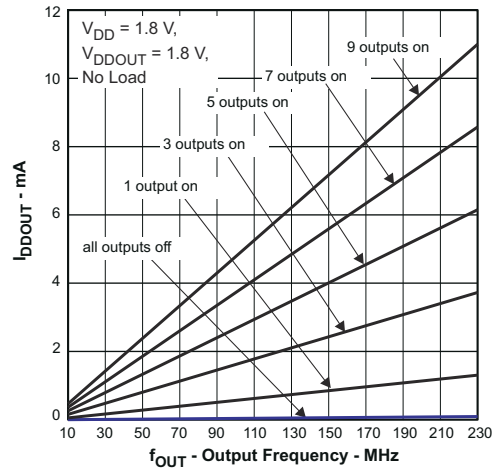
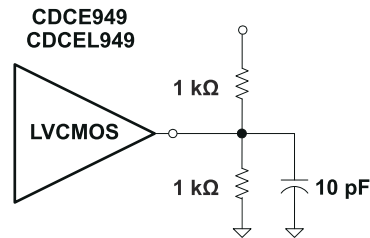

Figure 5-3. CDCEL949 Output Current vs Output Frequency

6 Parameter Measurement Information



Copyright © 2016, Texas Instruments Incorporated

Figure 6-1. Test Load

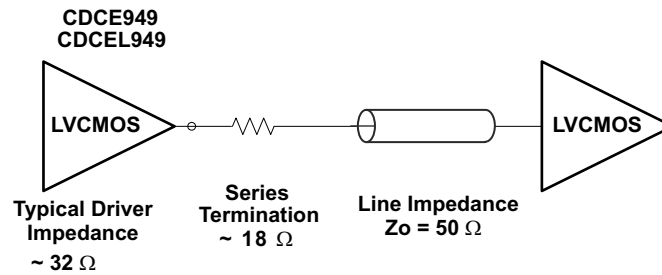

Copyright © 2016, Texas Instruments Incorporated

Figure 6-2. Test Load for 50-Ω Board Environment

7 Detailed Description

7.1 Overview

The CDCE949 and CDCEL949 devices are modular PLL-based, low-cost, high-performance, programmable clock synthesizers, multipliers, and dividers. They generate up to nine output clocks from a single input frequency. Each output can be programmed in-system for any clock frequency up to 230 MHz, using one of the four integrated configurable PLLs.

The CDCE949 has separate output supply pins, V_{DDOUT} , which is 1.8 V for CDCEL949 and 2.5 V to 3.3 V for CDCE949.

The input accepts an external crystal or LVCMOS clock signal. If an external crystal is used, an on-chip load capacitor is adequate for most applications. The value of the load capacitor is programmable from 0 to 20 pF. Additionally, a selectable on-chip VCXO allows synchronization of the output frequency to an external control signal, that is, the PWM signal.

The deep M/N divider ratio allows the generation of 0-ppm audio and video, networking (WLAN, Bluetooth, Ethernet, GPS), or Interface (USB, IEEE1394, memory stick) clocks from a reference input frequency such as 27 MHz.

All PLLs support spread-spectrum clocking (SSC). SSC can be center-spread or down-spread clocking. This is a common technique to reduce electro-magnetic interference (EMI).

Based on the PLL frequency and the divider settings, the internal loop filter components are automatically adjusted to achieve high stability, and to optimize the jitter-transfer characteristics of each PLL.

The device supports non-volatile EEPROM programming for easy customization of the device to the application. The internal EEPROM of the CDCE949 is preset to a factory-default configuration (see [Default Device Setting](#)). The EEPROM can be reprogrammed to a different application configuration before PCB assembly, or reprogrammed by in-system programming. All device settings are programmable through the SDA and SCL bus, a 2-wire serial interface.

Three programmable control inputs, S0, S1 and S2, can be used to control various aspects of operation including frequency selection, changing the SSC parameters to lower EMI, PLL bypass, power down, and choosing between low level or 3-state for the output-disable function.

The CDCE949 operates in a 1.8-V environment within a temperature range of -40°C to 85°C .

7.2 Functional Block Diagram

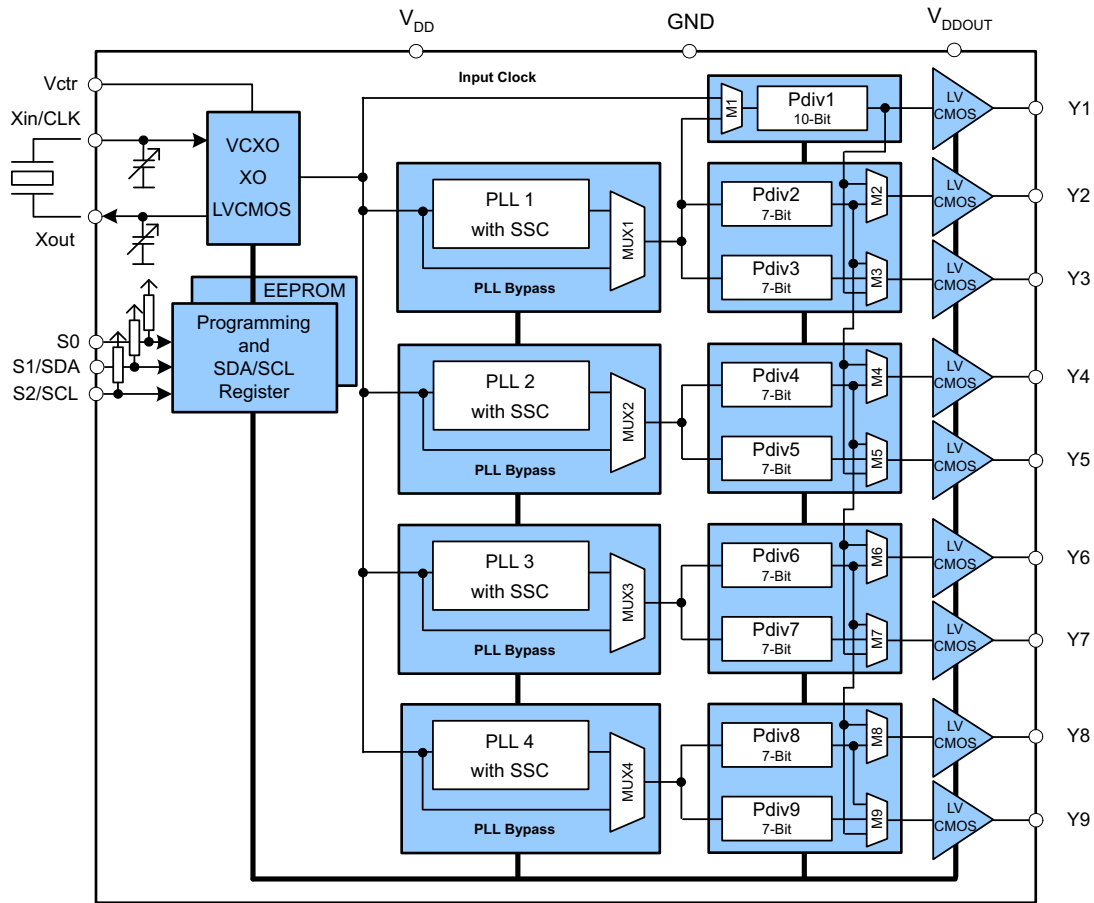

Copyright © 2016, Texas Instruments Incorporated

7.3 Feature Description

7.3.1 Control Terminal Setting

The CDCE949 has three user-definable control terminals (S0, S1, and S2) which allow external control of device settings. They can be programmed to any of the following setting:

- Spread spectrum clocking selection → spread type and spread amount selection
- Frequency selection → switching between any of two user-defined frequencies
- Output state selection → output configuration and power down control

The user can predefine up to eight different control settings. [Table 7-1](#) and [Table 7-2](#) explain these settings.

Table 7-1. Control Terminal Definition

EXTERNAL CONTROL BITS	PLL1 SETTING			PLL2 SETTING			PLL3 SETTING			PLL4 SETTING			Y1 SETTING
	PLL Frequency Selection	SSC Selection	Output Y2/Y3 Selection	PLL Frequency Selection	SSC Selection	Output Y4/Y5 Selection	PLL Frequency Selection	SSC Selection	Output Y6/Y7 Selection	PLL Frequency Selection	SSC Selection	Output Y8/Y9 Selection	
Control Function													Output Y1 and Power Down Selection

Table 7-2. PLLx Setting (Can Be Selected for Each PLL Individual)

SSC SELECTION (CENTER/DOWN) ⁽¹⁾					
SSCx [3-bits]			CENTER	DOWN	
0	0	0	0% (off)	0% (off)	
0	0	1	±0.25%	-0.25%	

Table 7-2. PLLx Setting (Can Be Selected for Each PLL Individual) (continued)

SSC SELECTION (CENTER/DOWN) ⁽¹⁾				
SSCx [3-bits]			CENTER	DOWN
0	1	0	±0.5%	–0.5%
0	1	1	±0.75%	–0.75%
1	0	0	±1%	–1%
1	0	1	±1.25%	–1.25%
1	1	0	±1.5%	–1.5%
1	1	1	±2%	–2%
FREQUENCY SELECTION ⁽²⁾				
FSx		FUNCTION		
0		Frequency0		
1		Frequency1		
OUTPUT SELECTION ⁽³⁾ (Y2 ... Y9)				
YxYx		FUNCTION		
0		State0		
1		State1		

- (1) Center/Down-Spread, Frequency0/1 and State0/1 are user-definable in PLLx Configuration Register
- (2) Frequency0 and Frequency1 can be any frequency within the specified f_{VCO} range
- (3) State0/1 selection is valid for both outputs of the corresponding PLL module and can be power down, 3-state, low, or active

Table 7-3. Y1 Setting⁽¹⁾

Y1 SELECTION	
Y1	FUNCTION
0	State 0
1	State 1

- (1) State0 and State1 are user definable in Generic Configuration Register and can be power down, 3-state, low, or active.

S1/SDA and S2/SCL pins of the CDCEx949 are dual function pins. In default configuration they are defined as SDA/SCL for the serial interface. They can be programmed as control-pins (S1/S2) by setting the relevant bits in the EEPROM. Note that the changes to the Control register (Bit [6] of Byte [02]) have no effect until they are written into the EEPROM.

Once they are set as control pins, the serial programming interface is no longer available. However, if V_{DDOUT} is forced to GND, the two control-pins, S1 and S2, temporally act as serial programming pins (SDA/SCL).

S0 is not a multi-use pin and is a control pin only.

7.3.2 Default Device Setting

The internal EEPROM of CDCEx949 is preconfigured as shown in [Figure 7-1](#) (the input frequency is passed through to the output as a default). This allows the device to operate in default mode without the extra production step of programming. The default setting appears after power is supplied or after power-down or power-up sequence until the setting is re-programmed by the user to a different application configuration. A new register setting is programmed through the serial SDA/SCL Interface.

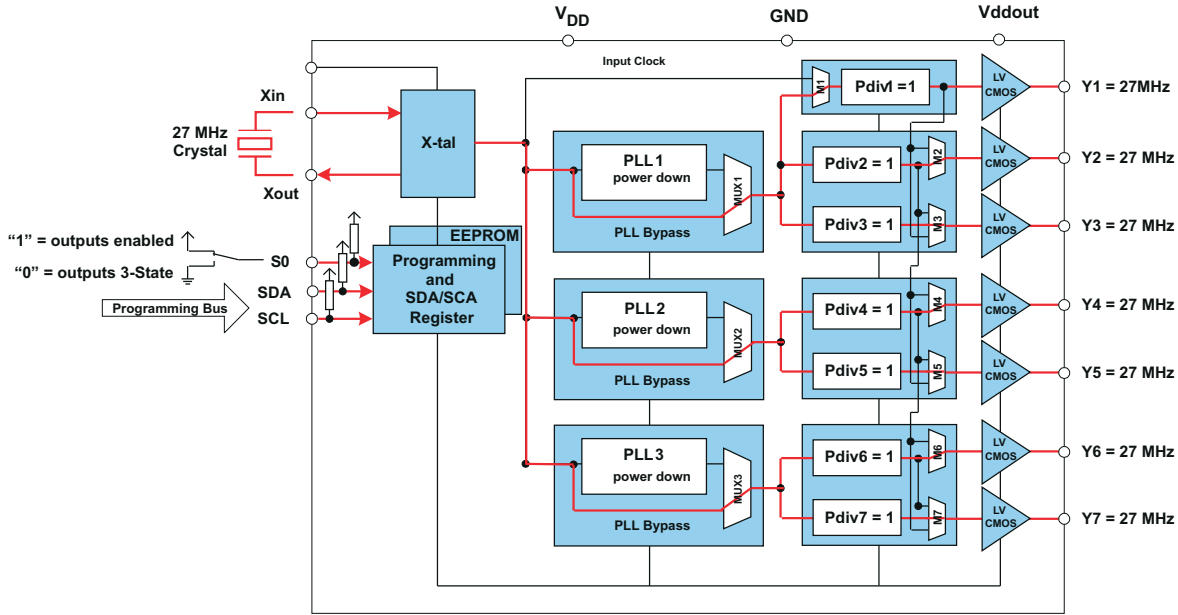

Figure 7-1. Default Device Setting

Table 7-4 shows the factory default setting for the Control Terminal Register (external control pins). In normal operation, all 8 register settings are available, but in the default configuration only the first two settings (0 and 1) can be selected with S0, as S1 and S2 configured as programming pins in default mode.

Table 7-4. Factory Default Setting for Control Terminal Register

EXTERNAL CONTROL PINS ⁽¹⁾			Y1	PLL1 SETTING			PLL2 SETTING			PLL3 SETTING			PLL3 SETTING		
S2	S1	S0	OUTPUT SELECT	FREQ. SELECT	SSC SEL.	OUTPUT SELECT	FREQ. SELECT	SSC SEL.	OUTPUT SELECT	FREQ. SELECT	SSC SEL.	OUTPUT SELECT	FREQ. SELECT	SSC SEL.	OUTPUT SELECT
SCL (I ² C)	SDA (I ² C)	0	3-state	f _{VCO1_0}	off	3-state	f _{VCO2_0}	off	3-state	f _{VCO3_0}	off	3-state	f _{VCO4_0}	off	3-state
SCL (I ² C)	SDA (I ² C)	1	enabled	f _{VCO1_0}	off	enabled	f _{VCO2_0}	off	enabled	f _{VCO3_0}	off	enabled	f _{VCO4_0}	off	enabled

(1) In default mode or when programmed respectively, S1 and S2 act as serial programming interface, SDA/SCL. They do not have any control-pin function but they are internally interpreted as if S1 = 0 and S2 = 0. However, S0 is a control-pin which in the default mode switches all outputs ON or OFF (as previously predefined).

7.3.3 SDA/SCL Serial Interface

The CDCE949 operates as a target device of the 2-wire serial SDA/SCL bus, compatible with the popular *SMBus* or *I²C Bus* specification. The device operates in the standard-mode transfer (up to 100 kbps) and fast-mode transfer (up to 400 kbps) and supports 7-bit addressing.

The S1/SDA and S2/SCL pins of the CDCE949 are dual function pins. In the default configuration they are used as SDA/SCL serial programming interface. They can be re-programmed as general-purpose control pins, S1 and S2, by changing the corresponding EEPROM setting, Byte 02, Bit [6].

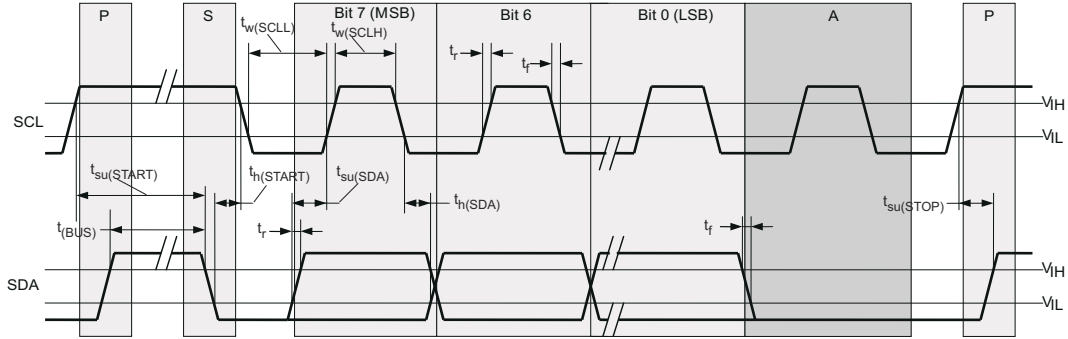

Figure 7-2. Timing Diagram for SDA/SCL Serial Control Interface

7.3.4 Data Protocol

The device supports *Byte Write and Byte Read* and *Block Write and Block Read* operations.

For *Byte Write/Read* operations, the system controller can individually access addressed bytes.

For *Block Write/Read* operations, the bytes are accessed in sequential order from lowest to highest byte (with most significant bit first) with the ability to stop after any complete byte has been transferred. The numbers of Bytes read-out are defined by Byte Count in the Generic Configuration Register. At Block Read instruction all bytes defined in the Byte Count has to be readout to correctly finish the read cycle.

After a byte is sent, the byte is written into the internal register and is effective immediately. This applies to each transferred byte independent of whether this is a *Byte Write* or a *Block Write* sequence.

If the EEPROM Write Cycle is initiated, the internal SDA register contents are written into the EEPROM. During this write cycle, data is not accepted at the SDA/SCL bus until the write cycle is completed. However, data can be read during the programming sequence (Byte Read or Block Read). The programming status can be monitored by reading *EEPIP*, Byte 01–Bit [6].

The offset of the indexed byte is encoded in the command code, as described in [Table 7-5](#).

Table 7-5. Target Receiver Address (7 Bits)

DEVICE	A6	A5	A4	A3	A2	A1 ⁽¹⁾	A0 ⁽¹⁾	R/ W
CDCEX913	1	1	0	0	1	0	1	1/0
CDCEX925	1	1	0	0	1	0	0	1/0
CDCEX937	1	1	0	1	1	0	1	1/0
CDCEX949	1	1	0	1	1	0	0	1/0

(1) Address bits A0 and A1 are programmable through the SDA/SCL bus (Byte 01, Bit [1:0]). This allows addressing up to 4 devices connected to the same SDA/SCL bus. The least-significant bit of the address byte designates a write or read operation.

7.4 Device Functional Modes

7.4.1 SDA/SCL Hardware Interface

[Figure 7-3](#) shows how the CDCEX949 clock synthesizer is connected to the SDA/SCL serial interface bus. Multiple devices can be connected to the bus but the speed may need to be reduced (400 kHz is the maximum) if many devices are connected.

Note that the pullup resistor value (R_P) depends on the supply voltage, bus capacitance and number of connected devices. The recommended pullup value is 4.7 kΩ. The value must meet the minimum sink current of 3 mA at $V_{OLmax} = 0.4$ V for the output stages (for more details, see [SMBus](#) or [I²C Bus](#) specification).

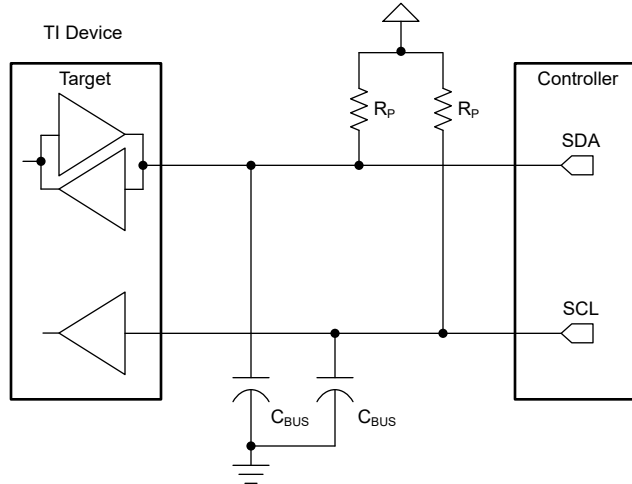

Figure 7-3. SDA/SCL Hardware Interface

7.5 Programming

Table 7-6. Command Code Definition

BIT	DESCRIPTION
7	0 = Block Read or Block Write operation 1 = Byte Read or Byte Write operation
(6:0)	Byte Offset for Byte Read, Block Read, Byte Write and Block Write operation.

Figure 7-4. Generic Programming

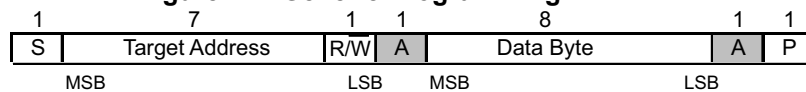

- S** Start Condition
- Sr** Repeated Start Condition
- R/W** 1 = Read (Rd) From CDCE9xx Device; 0 = Write (Wr) to CDCE9xxx
- A** Acknowledge (ACK = 0 and NACK =1)
- P** Stop Condition
- Controller-to-Target Transmission
- Sequence** Target-to-Controller Transmission

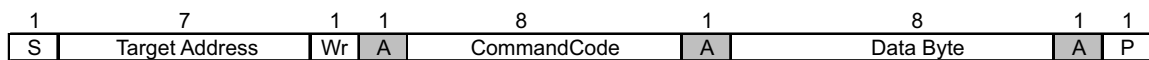

Figure 7-5. Byte Write Protocol

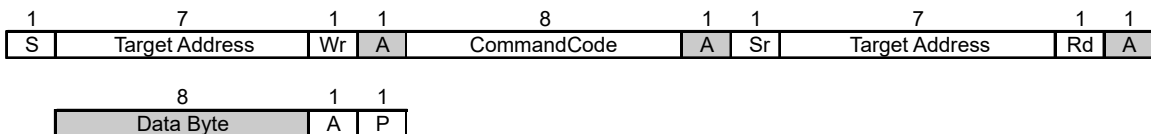
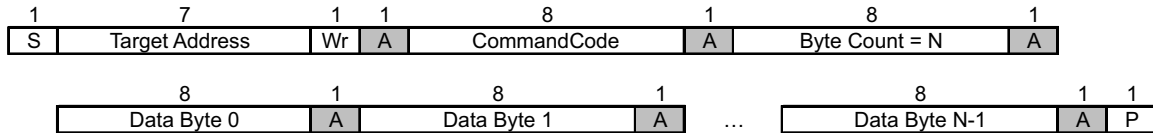

Figure 7-6. Byte Read Protocol



Data Byte 0 Bits [7:0] are reserved for Revision Code and Vendor Identification. The Data Byte 0 is used for internal test purpose and must not be overwritten.

Figure 7-7. Block Write Programming

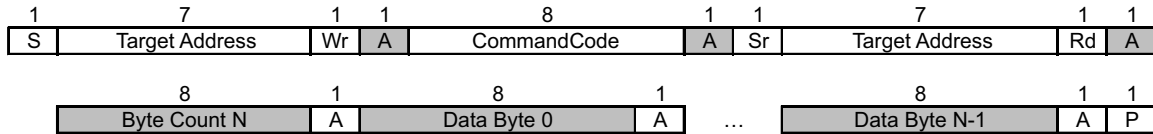

Figure 7-8. Block Read Protocol

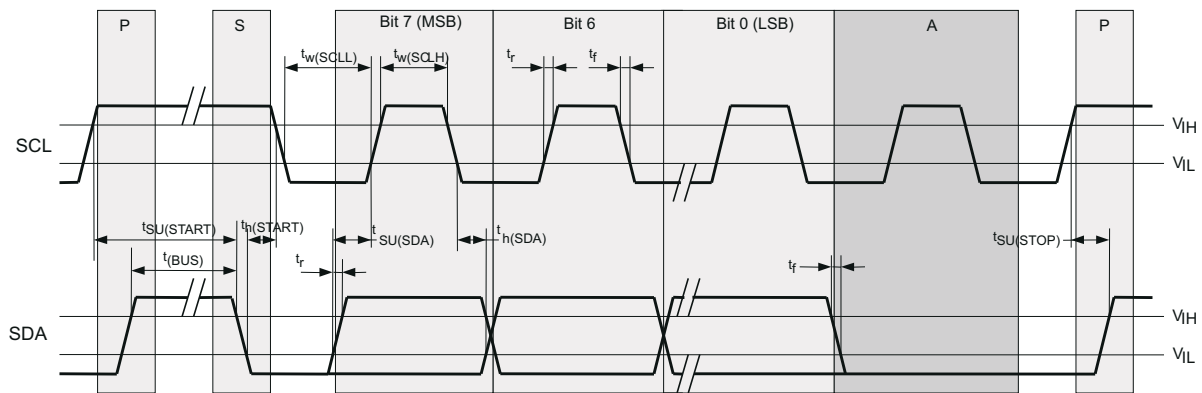

Figure 7-9. Timing Diagram for the SDA/SCL Serial Control Interface

8 Application and Implementation

Note

Information in the following applications sections is not part of the TI component specification, and TI does not warrant its accuracy or completeness. TI's customers are responsible for determining suitability of components for their purposes, as well as validating and testing their design implementation to confirm system functionality.

8.1 Application Information

The CDCE949 device is an easy-to-use high-performance, programmable CMOS clock synthesizer. The device can be used as a crystal buffer, clock synthesizer with separate output supply pin. The CDCE949 features an on-chip loop filter and Spread-spectrum modulation. Programming can be done through SPI, pin-mode, or using on-chip EEPROM. This section shows some examples of using CDCE949 in various applications.

8.2 Typical Application

Figure 8-1 shows the use of the CDCE949 devices for replacement of crystals and crystal oscillators on a Gigabit Ethernet Switch application.

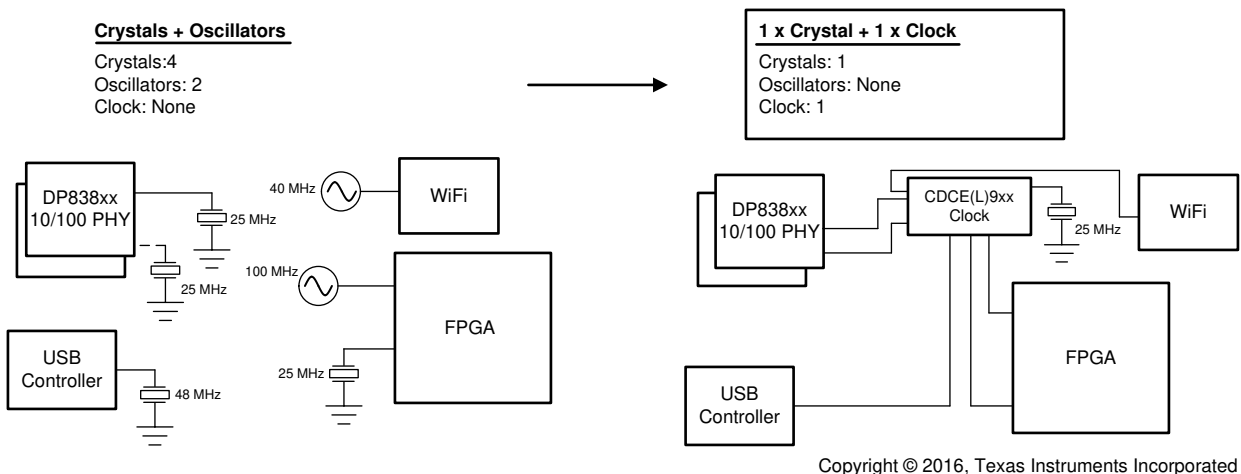

Figure 8-1. Crystal and Oscillator Replacement Example

8.2.1 Design Requirements

CDCE949 supports spread spectrum clocking (SSC) with multiple control parameters:

- Modulation amount (%)
- Modulation frequency (>20 kHz)
- Modulation shape (triangular)
- Center spread / down spread (\pm or $-$)

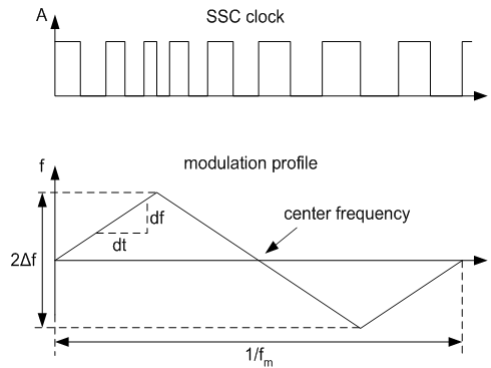
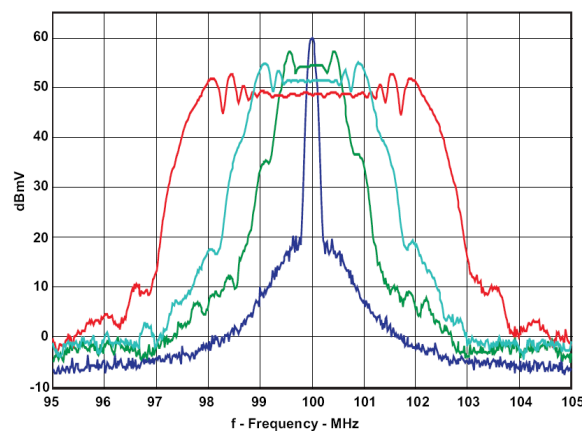

Figure 8-2. Modulation Frequency (fm) and Modulation Amount

8.2.2 Detailed Design Procedure

8.2.2.1 Spread Spectrum Clock (SSC)

Spread spectrum modulation is a method to spread emitted energy over a larger bandwidth. In clocking, spread spectrum can reduce Electromagnetic Interference (EMI) by reducing the level of emission from clock distribution network.



CDCS502 with a 25-MHz Crystal, FS = 1, Fout = 100 MHz, and 0%, ±0.5, ±1%, and ±2% SSC

Figure 8-3. Comparison Between Typical Clock Power Spectrum and Spread-Spectrum Clock

8.2.2.2 PLL Frequency Planning

At a given input frequency (f_{IN}), use Equation 1 to calculate the output frequency (f_{OUT}) of the CDCEx949.

$$f_{OUT} = \frac{f_{IN}}{Pdiv} \times \frac{N}{M} \tag{1}$$

where

- M (1 to 511) and N (1 to 4095) are the multiplier/divide values of the PLL
- Pdiv (1 to 127) is the output divider

Use Equation 2 to calculate the target VCO frequency (f_{VCO}) of each PLL.

$$f_{VCO} = f_{IN} \times \frac{N}{M} \tag{2}$$

The PLL internally operates as fractional divider and requires the following multiplier/divider settings:

- N
- $P = 4 - \text{int}(\log_2 N/M)$; if $P < 0$ then $P = 0$
- $Q = \text{int}(N'/M)$
- $R = N' - M \times Q$

where

$$N' = N \times 2^P$$

$$N \geq M;$$

$$80 \text{ MHz} \leq f_{VCO} \leq 230 \text{ MHz}$$

$$16 \leq Q \leq 63$$

$$0 \leq P \leq 4$$

$$0 \leq R \leq 51$$

Example:

for $f_{IN} = 27 \text{ MHz}$; $M = 1$; $N = 4$; $P_{div} = 2$

- $f_{OUT} = 54 \text{ MHz}$
- $f_{VCO} = 108 \text{ MHz}$
- $P = 4 - \text{int}(\log_2 4) = 4 - 2 = 2$
- $N' = 4 \times 2^2 = 16$
- $Q = \text{int}(16) = 16$
- $R = 16 - 16 = 0$

for $f_{IN} = 27 \text{ MHz}$; $M = 2$; $N = 11$; $P_{div} = 2$

- $f_{OUT} = 74.25 \text{ MHz}$
- $f_{VCO} = 148.50 \text{ MHz}$
- $P = 4 - \text{int}(\log_2 5.5) = 4 - 2 = 2$
- $N' = 11 \times 2^2 = 44$
- $Q = \text{int}(22) = 22$
- $R = 44 - 44 = 0$

The values for P, Q, R, and N' are automatically calculated when using TI Pro-Clock™ software.

8.2.2.3 Crystal Oscillator Start-Up

When the CDCE949 is used as a crystal buffer, crystal oscillator start-up dominates the start-up time compared to the internal PLL lock time. The following diagram shows the oscillator start-up sequence for a 27-MHz crystal input with an 8-pF load. The start-up time for the crystal is in the order of approximately 250 μs compared to approximately 10 μs of lock time. In general, lock time is an order of magnitude less compared to the crystal start-up time.

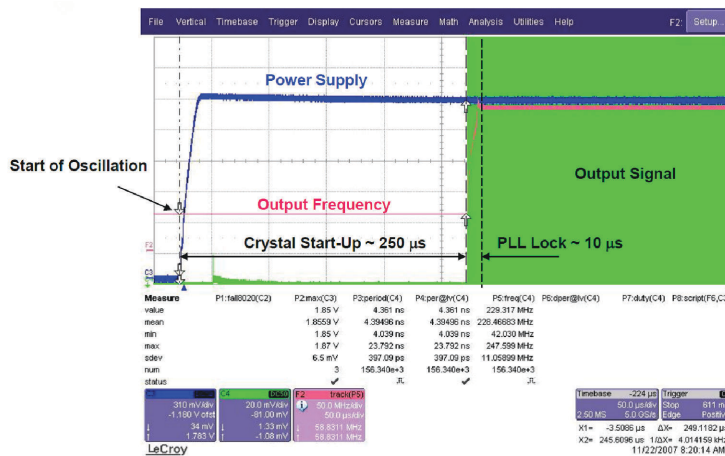

Figure 8-4. Crystal Oscillator Start-Up vs PLL Lock Time

8.2.2.4 Frequency Adjustment With Crystal Oscillator Pulling

The frequency for the CDCE949 is adjusted for media and other applications with the VCXO control input V_{Ctrl} . If a PWM modulated signal is used as a control signal for the VCXO, an external filter is needed.

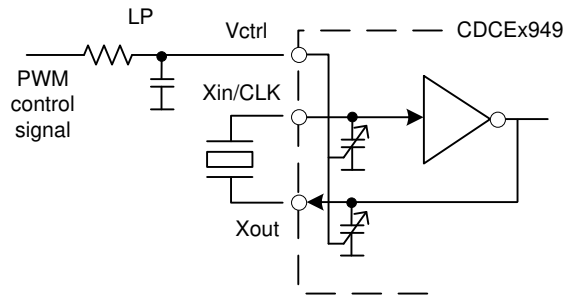

Figure 8-5. Frequency Adjustment Using PWM Input to the VCXO Control

8.2.2.5 Unused Inputs and Outputs

If VCXO pulling functionality is not required, leave V_{Ctrl} floating. Set all other unused inputs to GND. Leave unused outputs floating.

If one output block is not used, TI recommends disabling the that output block. However, TI always recommends providing the supply for the second output block even if the second output block is disabled.

8.2.2.6 Switching Between XO and VCXO Mode

When the CDCE949 is in crystal oscillator or in VCXO configuration, the internal capacitors require different internal capacitance. The following steps are recommended to switch to VCXO mode when the configuration for the on-chip capacitor is still set for XO mode. To center the output frequency to 0 ppm:

1. While in XO mode, put $V_{ctrl} = V_{dd}/2$
2. Switch from XO mode to VCXO mode
3. Program the internal capacitors to obtain 0 ppm at the output.

8.2.3 Application Curves

Figure 8-6, Figure 8-7, Figure 8-8, and Figure 8-9 show CDCE949 measurements with the SSC feature enabled. Device configuration: 27-MHz input, 27-MHz output.

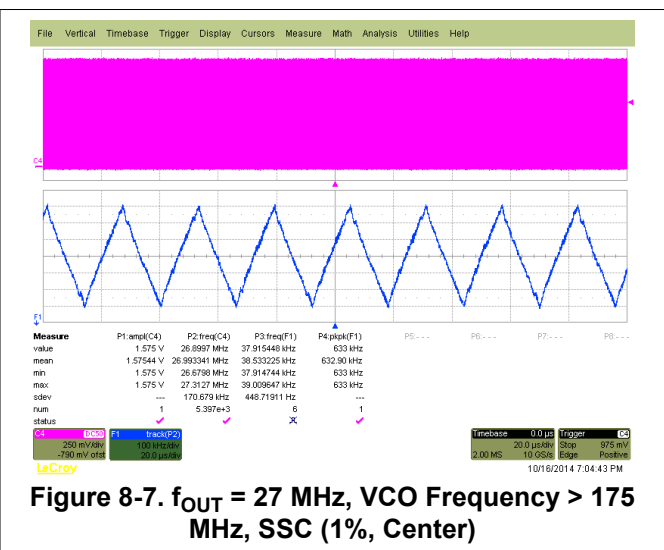
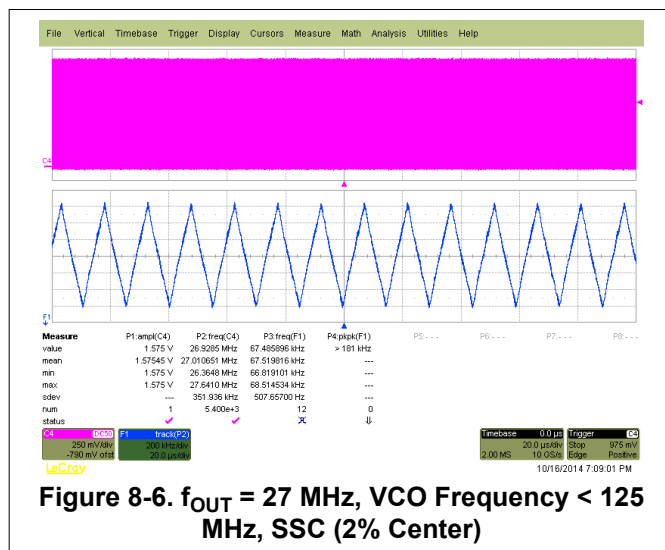

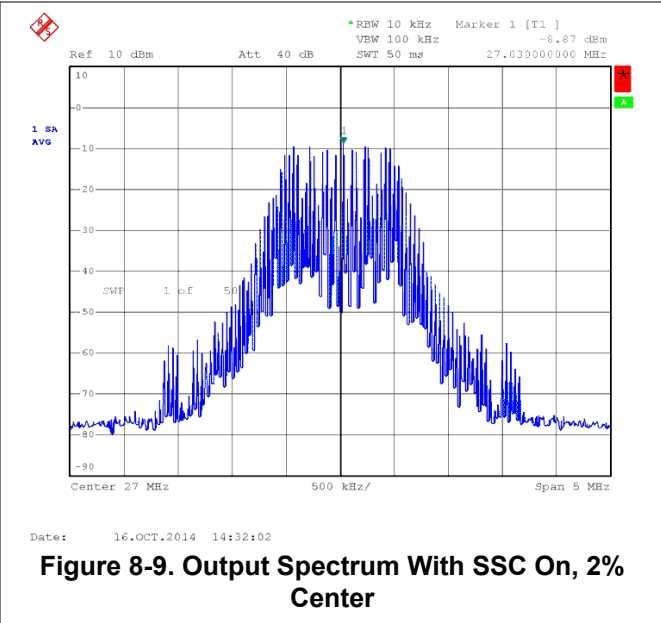
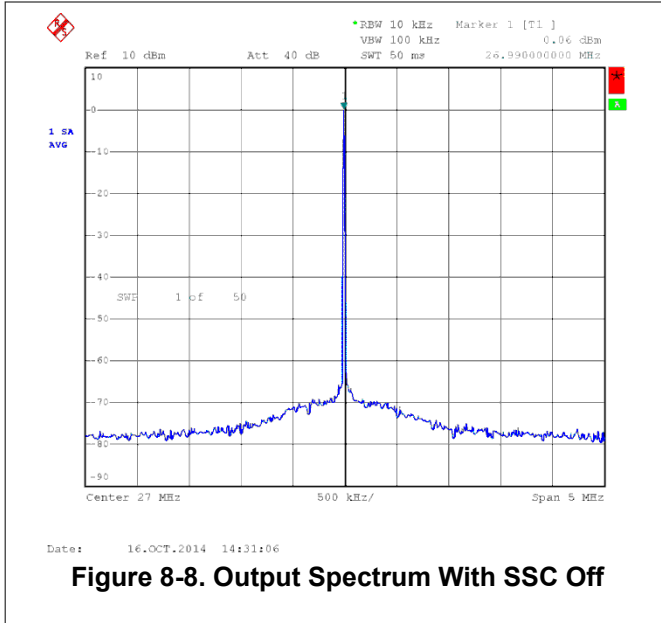

8.3 Power Supply Recommendations

There is no restriction on the power-up sequence. In case the V_{DDOUT} is applied first, TI recommends grounding the V_{DD} . In case the V_{DDOUT} is powered while V_{DD} is floating, there is a risk of high current flowing on the V_{DDOUT} .

The device has a power-up control that is connected to the 1.8-V supply. This keeps the whole device disabled until the 1.8-V supply reaches a sufficient voltage level. Then the device switches on all internal components, including the outputs. If there is a 3.3-V V_{DDOUT} available before the 1.8-V, the outputs stay disabled until the 1.8-V supply reaches a certain level.

8.4 Layout

8.4.1 Layout Guidelines

When the CDCE949 is used as a crystal buffer, any parasitics across the crystal affects the pulling range of the VCXO. Therefore, take care placing the crystal units on the board. Crystals must be placed as close to the device as possible so that the routing lines from the crystal terminals to XIN and XOUT have the same length.

If possible, cut out both ground plane and power plane under the area where the crystal and the routing to the device are placed. In this area, always avoid routing any other signal line, as it can be a source of noise coupling.

Additional discrete capacitors can be required to meet the load capacitance specification of certain crystal. For example, a 10.7-pF load capacitor is not fully programmable on the chip, because the internal capacitor can range from 0 pF to 20 pF with steps of 1 pF. The 0.7-pF capacitor therefore can be discretely added on top of an internal 10-pF capacitor.

To minimize the inductive influence of the trace, TI recommends placing this small capacitor as close to the device as possible and symmetrically with respect to XIN and XOUT.

Figure 8-10 shows a conceptual layout detailing recommended placement of power supply bypass capacitors on the basis of CDCE949. For component side mounting, use 0402 body size capacitors to facilitate signal routing. Keep the connections between the bypass capacitors and the power supply on the device as short as possible. Ground the other side of the capacitor using a low-impedance connection to the ground plane.

8.4.2 Layout Example

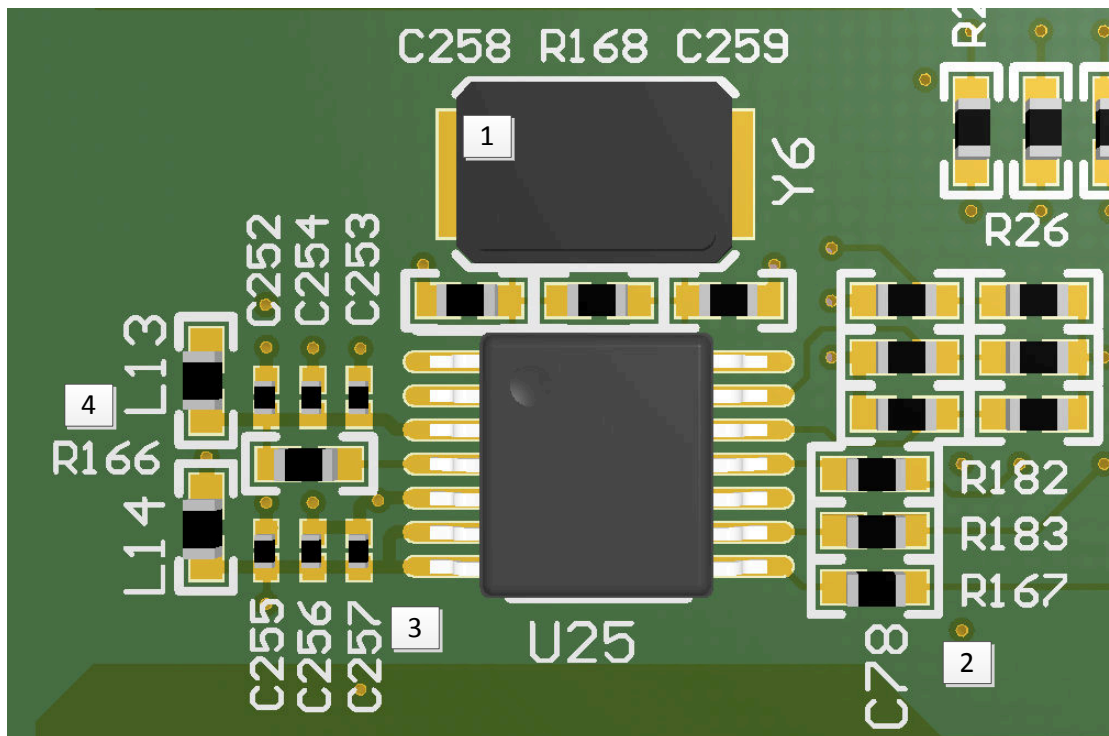

- | | | | |
|---|---|---|---|
| 1 | Place crystal with associated load caps as close to the chip | 2 | Place series termination resistors at Clock outputs to improve signal integrity |
| 3 | Place bypass caps close to the device pins, ensure wide freq. range | 4 | Use ferrite beads to isolate the device supply pins from board noise sources |

Figure 8-10. Annotated Layout

9 Register Maps

9.1 SDA/SCL Configuration Registers

The clock input, control pins, PLLs, and output stages are user configurable. The following tables and explanations describe the programmable functions of the CDCE949. All settings can be manually written to the device through the SDA/SCL bus, or are easily programmable by using the TI Pro Clock software. TI Pro Clock software allows the user to quickly make all settings and automatically calculates the values for optimized performance at lowest jitter.

Table 9-1. SDA/SCL Registers

ADDRESS OFFSET	REGISTER DESCRIPTION	TABLE
00h	Generic configuration register	Table 9-3
10h	PLL1 configuration register	Table 9-4
20h	PLL2 configuration register	Table 9-5
30h	PLL3 configuration register	Table 9-6
40h	PLL4 configuration register	Table 9-7

The grey-highlighted Bits described in the configuration registers tables on the following pages, belong to the Control Pin Register. The user can predefine up to eight different control settings. These settings can then be selected by the external control pins, S0, S1, and S2 (see [Control Terminal Setting](#)).

Table 9-2. Configuration Register, External Control Pins

EXTERNAL CONTROL PINS			PLL1 SETTING				PLL2 SETTING			PLL3 SETTING			PLL4 SETTING		
S2	S1	S0	OUTPUT SELECT	FREQ SELECT	SSC SELECT	OUTPUT SELECT	FREQ SELECT	SSC SELECT	OUTPUT SELECT	FREQ SELECT	SSC SELECT	OUTPUT SELECT	FREQ SELECT	SSC SELECT	OUTPUT SELECT
			Y1	FS1	SSC1	Y2Y3	FS2	SSC2	Y4Y5	FS3	SSC3	Y6Y7	FS4	SSC4	Y8Y9
0	0	0	Y1_0	FS1_0	SSC1_0	Y2Y3_0	FS2_0	SSC2_0	Y4Y5_0	FS3_0	SSC3_0	Y6Y7_0	FS4_0	SSC4_0	Y8Y9_0
0	0	1	Y1_1	FS1_1	SSC1_1	Y2Y3_1	FS2_1	SSC2_1	Y4Y5_1	FS3_1	SSC3_1	Y6Y7_1	FS4_1	SSC4_1	Y8Y9_1
0	1	0	Y1_2	FS1_2	SSC1_2	Y2Y3_2	FS2_2	SSC2_2	Y4Y5_2	FS3_2	SSC3_2	Y6Y7_2	FS4_2	SSC4_2	Y8Y9_2
0	1	1	Y1_3	FS1_3	SSC1_3	Y2Y3_3	FS2_3	SSC2_3	Y4Y5_3	FS3_3	SSC3_3	Y6Y7_3	FS4_3	SSC4_3	Y8Y9_3
1	0	0	Y1_4	FS1_4	SSC1_4	Y2Y3_4	FS2_4	SSC2_4	Y4Y5_4	FS3_4	SSC3_4	Y6Y7_4	FS4_4	SSC4_4	Y8Y9_4
1	0	1	Y1_5	FS1_5	SSC1_5	Y2Y3_5	FS2_5	SSC2_5	Y4Y5_5	FS3_5	SSC3_5	Y6Y7_5	FS4_5	SSC4_5	Y8Y9_5
1	1	0	Y1_6	FS1_6	SSC1_6	Y2Y3_6	FS2_6	SSC2_6	Y4Y5_6	FS3_6	SSC3_6	Y6Y7_6	FS4_6	SSC4_6	Y8Y9_6
1	1	1	Y1_7	FS1_7	SSC1_7	Y2Y3_7	FS2_7	SSC2_7	Y4Y5_7	FS3_7	SSC3_7	Y6Y7_7	FS4_7	SSC4_7	Y8Y9_7
Addr. Offset ⁽¹⁾			04h	13h	10h-12h	15h	23h	20h-22h	25h	33h	30h-32h	35h	43h	40h-42h	45h

(1) Address Offset refers to the byte address in the Configuration Register on following pages.

Table 9-3. Generic Configuration Register

OFFSET ⁽¹⁾	BIT ⁽²⁾	ACRONYM	DEFAULT ⁽³⁾	DESCRIPTION
00h	7	E_EL	xb	Device Identification (read only): '1' is CDCE949 (3.3V), '0' is CDCEL949 (1.8V)
	6:4	RID	Xb	Revision Identification Number (read only)
	3:0	VID	1h	Vendor Identification Number (read only)
01h	7	–	0b	Reserved - always write 0
	6	EEPIP	0b	EEPROM Programming Status ⁽⁴⁾ : (read only) 0 – EEPROM programming is completed 1 – EEPROM is in programming mode
	5	EELOCK	0b	Permanently Lock EEPROM Data ⁽⁵⁾ : 0 – EEPROM is not locked 1 – EEPROM is permanently locked
	4	PWDN	0b	Device power down (overwrites S0/S1/S2 setting; configuration register settings are unchanged) Note: PWDN cannot be set to 1 in the EEPROM. 0 – device active (all PLLs and all outputs are enabled) 1 – device power down (all PLLs in power down and all outputs in 3-State)
	3:2	INCLK	00b	Input clock selection: 00 – X-tal 10 – LVCMOS 01 – VCXO 11 – reserved
	1:0	TARGET_ADR	00b	Programmable Address Bits A0 and A1 of the Target Receiver Address

Table 9-3. Generic Configuration Register (continued)

OFFSET ⁽¹⁾	BIT ⁽²⁾	ACRONYM	DEFAULT ⁽³⁾	DESCRIPTION
02h	7	M1	1b	Clock source selection for output Y1: 0 – input clock 1 – PLL1 clock
	6	SPICON	0b	Operation mode selection for pin 22/23 ⁽⁶⁾ 0 – serial programming interface SDA (pin 23) and SCL (pin 22) 1 – control pins S1 (pin 23) and S2 (pin 22)
	5:4	Y1_ST1	11b	Y1-State0/1 Definition (applies to Y1_ST1 and Y1_ST0)
	3:2	Y1_ST0	01b	00 – device power down (all PLLs in power down and all outputs in 3-state) 01 – Y1 disabled to 3-state 10 – Y1 disabled to low 11 – Y1 enabled (normal operation)
	1:0	Pdiv1 [9:8]	001h	10-Bit Y1-Output-Divider Pdiv1: 0 – divider reset and stand-by 1-to-1023 – divider value
03h	7:0	Pdiv1 [7:0]		
04h	7	Y1_7	0b	Y1_x State Selection ⁽⁷⁾ 0 – State0 (predefined by Y1-State0 Definition [Y1_ST0]) 1 – State1 (predefined by Y1-State1 Definition [Y1_ST1])
	6	Y1_6	0b	
	5	Y1_5	0b	
	4	Y1_4	0b	
	3	Y1_3	0b	
	2	Y1_2	0b	
	1	Y1_1	1b	
	0	Y1_0	0b	
05h	7:3	XCSEL	0Ah	Crystal load capacitor selection ⁽⁸⁾ : 00h → 0 pF 01h → 1 pF 02h → 2 pF 14h-to-1Fh → 20 pF
	2:0	—	0b	Reserved - do not write others than 0
06h	7:1	BCOUNT	50h	7-Bit Byte Count (Defines the number of Bytes which is sent from this device at the next Block Read transfer; all bytes must be read out to correctly finish the read cycle.)
	0	EEWRITE	0b	Initiate EEPROM Write Cycle ^{(4) (9)} 0 – no EEPROM write cycle 1 – start EEPROM write cycle (internal configuration register is saved to the EEPROM)
07h-0Fh	—	—	0h	Reserved – do not write others than 0

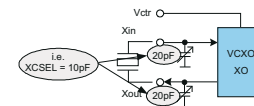

- (1) Writing data beyond 50h may adversely affect device function.
- (2) All data is transferred MSB-first.
- (3) Unless custom setting is used.
- (4) During EEPROM programming, no data is allowed to be sent to the device through the SDA/SCL bus until the programming sequence is completed. Data, however, can be read during the programming sequence (Byte Read or Block Read).
- (5) If this bit is set high in the EEPROM, the actual data in the EEPROM is permanently locked, and no further programming is possible. Data, however can still be written through the SDA/SCL bus to the internal register to change device function on the fly. But new data can no longer be saved to the EEPROM. EELOCK is effective only if written into the EEPROM
- (6) Selection of *control-pins* is effective only if written into the EEPROM. Once written into the EEPROM, the serial programming pins are no longer available. However, if V_{DDOUT} is forced to GND, the two control-pins, S1 and S2, temporarily act as serial programming pins (SDA/SCL), and the two target receiver address bits are reset to A0 = 0 and A1 = 0.
- (7) These are the bits of the Control Pin Register. The user can predefine up to eight different control settings. These settings can then be selected by the external control pins, S0, S1, and S2.
- (8) The internal load capacitor (C₁, C₂) must be used to achieve the best clock performance. External capacitors must be used only to do a fine adjustment of C_L by few pF. The value of C_L can be programmed with a resolution of 1 pF for a total crystal load range of 0 pF to 20 pF. For C_L > 20 pF use additional external capacitors. Also, the device input capacitance must be considered; this adds 1.5 pF (6 pF, 2 pF) to the selected C_L. For more information about VCXO configuration and crystal recommendations, see [VCXO Application Guideline for CDCE\(L\)9xx Family](#) (SCAA085).
- (9) NOTE: The EEPROM WRITE bit must be sent last to make sure the contents of all internal registers are written into the EEPROM. The EEWRITE cycle is initiated by the rising edge of the EEWRITE-Bit. A static level high does not trigger an EEPROM WRITE cycle. The EEWRITE-Bit must be reset low after the programming is completed. The programming status can be monitored by readout EEPIF. If EELOCK is set high, no EEPROM programming is possible.

Table 9-4. PLL1 Configuration Register

OFFSET ⁽¹⁾	BIT ⁽²⁾	ACRONYM	DEFAULT ⁽³⁾	DESCRIPTION																		
10h	7:5	SSC1_7 [2:0]	000b	SSC1: PLL1 SSC Selection (Modulation Amount)⁽⁴⁾ <table style="width: 100%; border: none;"> <tr> <td style="width: 50%;">Down</td> <td style="width: 50%;">Center</td> </tr> <tr> <td>000 (off)</td> <td>000 (off)</td> </tr> <tr> <td>001 – 0.25%</td> <td>001 ± 0.25%</td> </tr> <tr> <td>010 – 0.5%</td> <td>010 ± 0.5%</td> </tr> <tr> <td>011 – 0.75%</td> <td>011 ± 0.75%</td> </tr> <tr> <td>100 – 1.0%</td> <td>100 ± 1.0%</td> </tr> <tr> <td>101 – 1.25%</td> <td>101 ± 1.25%</td> </tr> <tr> <td>110 – 1.5%</td> <td>110 ± 1.5%</td> </tr> <tr> <td>111 – 2.0%</td> <td>111 ± 2.0%</td> </tr> </table>	Down	Center	000 (off)	000 (off)	001 – 0.25%	001 ± 0.25%	010 – 0.5%	010 ± 0.5%	011 – 0.75%	011 ± 0.75%	100 – 1.0%	100 ± 1.0%	101 – 1.25%	101 ± 1.25%	110 – 1.5%	110 ± 1.5%	111 – 2.0%	111 ± 2.0%
	Down	Center																				
	000 (off)	000 (off)																				
001 – 0.25%	001 ± 0.25%																					
010 – 0.5%	010 ± 0.5%																					
011 – 0.75%	011 ± 0.75%																					
100 – 1.0%	100 ± 1.0%																					
101 – 1.25%	101 ± 1.25%																					
110 – 1.5%	110 ± 1.5%																					
111 – 2.0%	111 ± 2.0%																					
4:2	SSC1_6 [2:0]	000b																				
1:0	SSC1_5 [2:1]	000b																				
11h	7	SSC1_5 [0]	000b																			
	6:4	SSC1_4 [2:0]																				
	3:1	SSC1_3 [2:0]																				
	0	SSC1_2 [2]																				
12h	7:6	SSC1_2 [1:0]	000b																			
	5:3	SSC1_1 [2:0]																				
	2:0	SSC1_0 [2:0]																				
13h	7	FS1_7	0b	FS1_x: PLL1 Frequency Selection⁽⁴⁾ 0 – f_{VCO1_0} (predefined by PLL1_0 – Multiplier/Divider value) 1 – f_{VCO1_1} (predefined by PLL1_1 – Multiplier/Divider value)																		
	6	FS1_6																				
	5	FS1_5																				
	4	FS1_4																				
	3	FS1_3																				
	2	FS1_2																				
	1	FS1_1																				
	0	FS1_0																				
14h	7	MUX1	1b	PLL1 Multiplexer: 0 – PLL1 1 – PLL1 Bypass (PLL1 is in power down)																		
	6	M2	1b	Output Y2 Multiplexer: 0 – Pdiv1 1 – Pdiv2																		
	5:4	M3	10b	Output Y3 Multiplexer: 00 – Pdiv1-Divider 01 – Pdiv2-Divider 10 – Pdiv3-Divider 11 – reserved																		
	3:2	Y2Y3_ST1	11b	Y2, Y3- State0/1definition: 00 – Y2/Y3 disabled to 3-State (PLL1 is in power down) 01 – Y2/Y3 disabled to 3-State (PLL1 on) 10 – Y2/Y3 disabled to low (PLL1 on) 11 – Y2/Y3 enabled (normal operation, PLL1 on)																		
	1:0	Y2Y3_ST0	01b																			
15h	7	Y2Y3_7	0b	Y2Y3_x Output State Selection⁽⁴⁾ 0 – state0 (predefined by Y2Y3_ST0) 1 – state1 (predefined by Y2Y3_ST1)																		
	6	Y2Y3_6																				
	5	Y2Y3_5																				
	4	Y2Y3_4																				
	3	Y2Y3_3																				
	2	Y2Y3_2																				
	1	Y2Y3_1																				
	0	Y2Y3_0																				
16h	7	SSC1DC	0b	PLL1 SSC down/center selection: 0 – down 1 – center																		
	6:0	Pdiv2	01h	7-Bit Y2-Output-Divider Pdiv2: 0 – reset and stand-by 1-to-127 – divider value																		
17h	7	—	0b	Reserved – do not write others than 0																		
	6:0	Pdiv3	01h	7-Bit Y3-Output-Divider Pdiv3: 0 – reset and stand-by 1-to-127 – divider value																		

Table 9-4. PLL1 Configuration Register (continued)

OFFSET ⁽¹⁾	BIT ⁽²⁾	ACRONYM	DEFAULT ⁽³⁾	DESCRIPTION	
18h	7:0	PLL1_0N [11:4]	004h	PLL1_0 ⁽⁵⁾ : 30-Bit Multiplier/Divider value for frequency f_{VCO1_0} (for more information, see PLL Frequency Planning)	
19h	7:4	PLL1_0N [3:0]			
	3:0	PLL1_0R [8:5]	000h		
1Ah	7:3	PLL1_0R[4:0]			
	2:0	PLL1_0Q [5:3]	10h		
1Bh	7:5	PLL1_0Q [2:0]			
	4:2	PLL1_0P [2:0]	010b		
1Bh	1:0	VCO1_0_RANGE	00b		f_{VCO1_0} range selection:
					00 – $f_{VCO1_0} < 125$ MHz 01 – $125 \text{ MHz} \leq f_{VCO1_0} < 150$ MHz 10 – $150 \text{ MHz} \leq f_{VCO1_0} < 175$ MHz 11 – $f_{VCO1_0} \geq 175$ MHz
1Ch	7:0	PLL1_1N [11:4]	004h		PLL1_1 ⁽⁵⁾ : 30-Bit Multiplier/Divider value for frequency f_{VCO1_1} (for more information, see PLL Frequency Planning).
1Dh	7:4	PLL1_1N [3:0]			
	3:0	PLL1_1R [8:5]	000h		
1Eh	7:3	PLL1_1R[4:0]			
	2:0	PLL1_1Q [5:3]	10h		
1Fh	7:5	PLL1_1Q [2:0]			
	4:2	PLL1_1P [2:0]	010b		
1Fh	1:0	VCO1_1_RANGE	00b	f_{VCO1_1} range selection:	
				00 – $f_{VCO1_1} < 125$ MHz 01 – $125 \text{ MHz} \leq f_{VCO1_1} < 150$ MHz 10 – $150 \text{ MHz} \leq f_{VCO1_1} < 175$ MHz 11 – $f_{VCO1_1} \geq 175$ MHz	

- (1) Writing data beyond 50h may adversely affect device function.
- (2) All data is transferred MSB-first.
- (3) Unless a custom setting is used
- (4) The user can predefine up to eight different control settings. In normal device operation, these settings can be selected by the external control pins, S0, S1, and S2.
- (5) PLL settings limits: $16 \leq q \leq 63$, $0 \leq p \leq 7$, $0 \leq r \leq 511$, $0 < N < 4096$

Table 9-5. PLL2 Configuration Register

OFFSET ⁽¹⁾	BIT ⁽²⁾	ACRONYM	DEFAULT ⁽³⁾	DESCRIPTION
20h	7:5	SSC2_7 [2:0]	000b	SSC2: PLL2 SSC Selection (Modulation Amount) ⁽⁴⁾
	4:2	SSC2_6 [2:0]	000b	
	1:0	SSC2_5 [2:1]	000b	
21h	7	SSC2_5 [0]		
	6:4	SSC2_4 [2:0]	000b	
	3:1	SSC2_3 [2:0]	000b	
	0	SSC2_2 [2]	000b	
22h	7:6	SSC2_2 [1:0]		
	5:3	SSC2_1 [2:0]	000b	
	2:0	SSC2_0 [2:0]	000b	
23h	7	FS2_7	0b	FS2_x: PLL2 Frequency Selection ⁽⁴⁾
	6	FS2_6	0b	
	5	FS2_5	0b	
	4	FS2_4	0b	
	3	FS2_3	0b	
	2	FS2_2	0b	
	1	FS2_1	0b	
	0	FS2_0	0b	

Table 9-5. PLL2 Configuration Register (continued)

OFFSET ⁽¹⁾	BIT ⁽²⁾	ACRONYM	DEFAULT ⁽³⁾	DESCRIPTION	
24h	7	MUX2	1b	PLL2 Multiplexer: 0 – PLL2 1 – PLL2 Bypass (PLL2 is in power down)	
	6	M4	1b	Output Y4 Multiplexer: 0 – Pdiv2 1 – Pdiv4	
	5:4	M5	10b	Output Y5 Multiplexer: 00 – Pdiv2-Divider 01 – Pdiv4-Divider 10 – Pdiv5-Divider 11 – reserved	
	3:2	Y4Y5_ST1	11b	Y4, Y5- State0/1definition: 00 – Y4/Y5 disabled to 3-State (PLL2 is in power down) 01 – Y4/Y5 disabled to 3-State (PLL2 on) 10 – Y4/Y5 disabled to low (PLL2 on) 11 – Y4/Y5 enabled (normal operation, PLL2 on)	
	1:0	Y4Y5_ST0	01b		
25h	7	Y4Y5_7	0b	Y4Y5_x Output State Selection ⁽⁴⁾ 0 – state0 (predefined by Y4Y5_ST0) 1 – state1 (predefined by Y4Y5_ST1)	
	6	Y4Y5_6	0b		
	5	Y4Y5_5	0b		
	4	Y4Y5_4	0b		
	3	Y4Y5_3	0b		
	2	Y4Y5_2	0b		
	1	Y4Y5_1	1b		
	0	Y4Y5_0	0b		
26h	7	SSC2DC	0b	PLL2 SSC down/center selection: 0 – down 1 – center	
	6:0	Pdiv4	01h	7-Bit Y4-Output-Divider Pdiv4: 0 – reset and stand-by 1-to-127 – divider value	
27h	7	—	0b	Reserved – do not write others than 0	
	6:0	Pdiv5	01h	7-Bit Y5-Output-Divider Pdiv5: 0 – reset and stand-by 1-to-127 – divider value	
28h	7:0	PLL2_0N [11:4]	004h	PLL2_0 ⁽⁵⁾ : 30-Bit Multiplier/Divider value for frequency f_{VCO2_0} (for more information, see PLL Frequency Planning).	
29h	7:4	PLL2_0N [3:0]			
	3:0	PLL2_0R [8:5]			
2Ah	7:3	PLL2_0R[4:0]			000h
	2:0	PLL2_0Q [5:3]			10h
2Bh	7:5	PLL2_0Q [2:0]	010b	f_{VCO2_0} range selection: 00 – $f_{VCO2_0} < 125$ MHz 01 – $125 \text{ MHz} \leq f_{VCO2_0} < 150$ MHz 10 – $150 \text{ MHz} \leq f_{VCO2_0} < 175$ MHz 11 – $f_{VCO2_0} \geq 175$ MHz	
	4:2	PLL2_0P [2:0]			
2Ch	7:0	PLL2_1N [11:4]	004h	PLL2_1 ⁽⁵⁾ : 30-Bit Multiplier/Divider value for frequency f_{VCO1_1} (for more information, see PLL Frequency Planning).	
2Dh	7:4	PLL2_1N [3:0]			
	3:0	PLL2_1R [8:5]			
2Eh	7:3	PLL2_1R[4:0]			000h
	2:0	PLL2_1Q [5:3]			10h
2Fh	7:5	PLL2_1Q [2:0]	010b	f_{VCO1_1} range selection: 00 – $f_{VCO1_1} < 125$ MHz 01 – $125 \text{ MHz} \leq f_{VCO1_1} < 150$ MHz 10 – $150 \text{ MHz} \leq f_{VCO1_1} < 175$ MHz 11 – $f_{VCO1_1} \geq 175$ MHz	
	4:2	PLL2_1P [2:0]			
	1:0	VCO2_1_RANGE	00b		

- (1) Writing data beyond 50h may adversely affect device function.
- (2) All data is transferred MSB-first.
- (3) Unless a custom setting is used
- (4) The user can predefine up to eight different control settings. In normal device operation, these settings can be selected by the external control pins, S0, S1, and S2.
- (5) PLL settings limits: $16 \leq q \leq 63$, $0 \leq p \leq 7$, $0 \leq r \leq 511$, $0 < N < 4096$

Table 9-6. PLL3 Configuration Register

OFFSET ⁽¹⁾	BIT ⁽²⁾	ACRONYM	DEFAULT ⁽³⁾	DESCRIPTION																		
30h	7:5	SSC3_7 [2:0]	000b	SSC3: PLL3 SSC Selection (Modulation Amount) ⁽⁴⁾ <table border="0"> <tr> <td style="text-align: center;">Down</td> <td style="text-align: center;">Center</td> </tr> <tr> <td>000 (off)</td> <td>000 (off)</td> </tr> <tr> <td>001 – 0.25%</td> <td>001 ± 0.25%</td> </tr> <tr> <td>010 – 0.5%</td> <td>010 ± 0.5%</td> </tr> <tr> <td>011 – 0.75%</td> <td>011 ± 0.75%</td> </tr> <tr> <td>100 – 1.0%</td> <td>100 ± 1.0%</td> </tr> <tr> <td>101 – 1.25%</td> <td>101 ± 1.25%</td> </tr> <tr> <td>110 – 1.5%</td> <td>110 ± 1.5%</td> </tr> <tr> <td>111 – 2.0%</td> <td>111 ± 2.0%</td> </tr> </table>	Down	Center	000 (off)	000 (off)	001 – 0.25%	001 ± 0.25%	010 – 0.5%	010 ± 0.5%	011 – 0.75%	011 ± 0.75%	100 – 1.0%	100 ± 1.0%	101 – 1.25%	101 ± 1.25%	110 – 1.5%	110 ± 1.5%	111 – 2.0%	111 ± 2.0%
	Down	Center																				
	000 (off)	000 (off)																				
001 – 0.25%	001 ± 0.25%																					
010 – 0.5%	010 ± 0.5%																					
011 – 0.75%	011 ± 0.75%																					
100 – 1.0%	100 ± 1.0%																					
101 – 1.25%	101 ± 1.25%																					
110 – 1.5%	110 ± 1.5%																					
111 – 2.0%	111 ± 2.0%																					
4:2	SSC3_6 [2:0]	000b																				
1:0	SSC3_5 [2:1]	000b																				
31h	7	SSC3_5 [0]	000b																			
	6:4	SSC3_4 [2:0]																				
	3:1	SSC3_3 [2:0]																				
	0	SSC3_2 [2]																				
32h	7:6	SSC3_2 [1:0]	000b																			
	5:3	SSC3_1 [2:0]																				
	2:0	SSC3_0 [2:0]																				
33h	7	FS3_7	0b	FS3_x: PLL3 Frequency Selection ⁽⁴⁾ 0 – f_{VCO3_0} (predefined by PLL3_0 – Multiplier/Divider value) 1 – f_{VCO3_1} (predefined by PLL3_1 – Multiplier/Divider value)																		
	6	FS3_6	0b																			
	5	FS3_5	0b																			
	4	FS3_4	0b																			
	3	FS3_3	0b																			
	2	FS3_2	0b																			
	1	FS3_1	0b																			
	0	FS3_0	0b																			
34h	7	MUX3	1b	PLL3 Multiplexer: 0 – PLL3 1 – PLL3 Bypass (PLL3 is in power down)																		
	6	M6	1b	Output Y6 Multiplexer: 0 – Pdiv4 1 – Pdiv6																		
	5:4	M7	10b	Output Y7 Multiplexer: 00 – Pdiv4-Divider 01 – Pdiv6-Divider 10 – Pdiv7-Divider 11 – reserved																		
	3:2	Y6Y7_ST1	11b	Y6, Y7- State0/1 definition: 00 – Y6/Y7 disabled to 3-State (PLL3 is in power down) 01 – Y6/Y7 disabled to 3-State (PLL3 on) 10 – Y6/Y7 disabled to low (PLL3 on) 11 – Y6/Y7 enabled (normal operation, PLL3 on)																		
	1:0	Y6Y7_ST0	01b																			
35h	7	Y6Y7_7	0b	Y6Y7_x Output State Selection ⁽⁴⁾ 0 – state0 (predefined by Y6Y7_ST0) 1 – state1 (predefined by Y6Y7_ST1)																		
	6	Y6Y7_6	0b																			
	5	Y6Y7_5	0b																			
	4	Y6Y7_4	0b																			
	3	Y6Y7_3	0b																			
	2	Y6Y7_2	0b																			
	1	Y6Y7_1	1b																			
	0	Y6Y7_0	0b																			
36h	7	SSC3DC	0b	PLL3 SSC down/center selection: 0 – down 1 – center																		
	6:0	Pdiv6	01h	7-Bit Y6-Output-Divider Pdiv6: 0 – reset and stand-by 1-to-127 – divider value																		
37h	7	—	0b	Reserved – do not write others than 0																		
	6:0	Pdiv7	01h	7-Bit Y7-Output-Divider Pdiv7: 0 – reset and stand-by 1-to-127 – divider value																		

Table 9-6. PLL3 Configuration Register (continued)

OFFSET ⁽¹⁾	BIT ⁽²⁾	ACRONYM	DEFAULT ⁽³⁾	DESCRIPTION
38h	7:0	PLL3_0N [11:4]	004h	PLL3_0 ⁽⁵⁾ : 30-Bit Multiplier/Divider value for frequency f_{VCO3_0} (for more information, see PLL Frequency Planning).
39h	7:4	PLL3_0N [3:0]	000h	
	3:0	PLL3_0R [8:5]		
3Ah	7:3	PLL3_0R[4:0]	10h	
	2:0	PLL3_0Q [5:3]		
3Bh	7:5	PLL3_0Q [2:0]	010b	
	4:2	PLL3_0P [2:0]		
	1:0	VCO3_0_RANGE		f_{VCO3_0} range selection: 00 – $f_{VCO3_0} < 125$ MHz 01 – $125 \text{ MHz} \leq f_{VCO3_0} < 150$ MHz 10 – $150 \text{ MHz} \leq f_{VCO3_0} < 175$ MHz 11 – $f_{VCO3_0} \geq 175$ MHz
3Ch	7:0	PLL3_1N [11:4]	004h	PLL3_1 ⁽⁵⁾ : 30-Bit Multiplier/Divider value for frequency f_{VCO3_1} (for more information, see PLL Frequency Planning).
3Dh	7:4	PLL3_1N [3:0]	000h	
	3:0	PLL3_1R [8:5]		
3Eh	7:3	PLL3_1R[4:0]	10h	
	2:0	PLL3_1Q [5:3]		
3Fh	7:5	PLL3_1Q [2:0]	010b	
	4:2	PLL3_1P [2:0]		
	1:0	VCO3_1_RANGE		f_{VCO3_1} range selection: 00 – $f_{VCO3_1} < 125$ MHz 01 – $125 \text{ MHz} \leq f_{VCO3_1} < 150$ MHz 10 – $150 \text{ MHz} \leq f_{VCO3_1} < 175$ MHz 11 – $f_{VCO3_1} \geq 175$ MHz

- (1) Writing data beyond 50h may adversely affect device function.
- (2) All data is transferred MSB-first.
- (3) Unless a custom setting is used
- (4) The user can predefine up to eight different control settings. In normal device operation, these settings can be selected by the external control pins, S0, S1, and S2.
- (5) PLL settings limits: $16 \leq q \leq 63$, $0 \leq p \leq 7$, $0 \leq r \leq 511$, $0 < N < 4096$

Table 9-7. PLL4 Configuration Register

OFFSET ⁽¹⁾	BIT ⁽²⁾	ACRONYM	DEFAULT ⁽³⁾	DESCRIPTION																		
40h	7:5	SSC4_7 [2:0]	000b	SSC4: PLL4 SSC Selection (Modulation Amount) ⁽⁴⁾ <table style="width: 100%; border: none;"> <tr> <td style="text-align: center;">Down</td> <td style="text-align: center;">Center</td> </tr> <tr> <td>000 (off)</td> <td>000 (off)</td> </tr> <tr> <td>001 – 0.25%</td> <td>001 ± 0.25%</td> </tr> <tr> <td>010 – 0.5%</td> <td>010 ± 0.5%</td> </tr> <tr> <td>011 – 0.75%</td> <td>011 ± 0.75%</td> </tr> <tr> <td>100 – 1.0%</td> <td>100 ± 1.0%</td> </tr> <tr> <td>101 – 1.25%</td> <td>101 ± 1.25%</td> </tr> <tr> <td>110 – 1.5%</td> <td>110 ± 1.5%</td> </tr> <tr> <td>111 – 2.0%</td> <td>111 ± 2.0%</td> </tr> </table>	Down	Center	000 (off)	000 (off)	001 – 0.25%	001 ± 0.25%	010 – 0.5%	010 ± 0.5%	011 – 0.75%	011 ± 0.75%	100 – 1.0%	100 ± 1.0%	101 – 1.25%	101 ± 1.25%	110 – 1.5%	110 ± 1.5%	111 – 2.0%	111 ± 2.0%
	Down	Center																				
	000 (off)	000 (off)																				
001 – 0.25%	001 ± 0.25%																					
010 – 0.5%	010 ± 0.5%																					
011 – 0.75%	011 ± 0.75%																					
100 – 1.0%	100 ± 1.0%																					
101 – 1.25%	101 ± 1.25%																					
110 – 1.5%	110 ± 1.5%																					
111 – 2.0%	111 ± 2.0%																					
4:2	SSC4_6 [2:0]	000b																				
1:0	SSC4_5 [2:1]	000b																				
7	SSC4_5 [0]																					
41h	6:4	SSC4_4 [2:0]	000b																			
	3:1	SSC4_3 [2:0]	000b																			
	0	SSC4_2 [2]	000b																			
42h	7:6	SSC4_2 [1:0]	000b																			
	5:3	SSC4_1 [2:0]																				
	2:0	SSC4_0 [2:0]																				
43h	7	FS4_7	0b	FS4_x: PLL4 Frequency Selection ⁽⁴⁾ sl $0 - f_{VCO4_0}$ (predefined by PLL4_0 – Multiplier/Divider value) $1 - f_{VCO4_1}$ (predefined by PLL4_1 – Multiplier/Divider value)																		
	6	FS4_6	0b																			
	5	FS4_5	0b																			
	4	FS4_4	0b																			
	3	FS4_3	0b																			
	2	FS4_2	0b																			
	1	FS4_1	0b																			
	0	FS4_0	0b																			

Table 9-7. PLL4 Configuration Register (continued)

OFFSET ⁽¹⁾	BIT ⁽²⁾	ACRONYM	DEFAULT ⁽³⁾	DESCRIPTION	
44h	7	MUX4	1b	PLL4 Multiplexer: 0 – PLL4 1 – PLL4 Bypass (PLL4 is in power down)	
	6	M8	1b	Output Y8 Multiplexer: 0 – Pdiv6 1 – Pdiv8	
	5:4	M9	10b	Output Y9 Multiplexer: 00 – Pdiv6-Divider 01 – Pdiv8-Divider 10 – Pdiv9-Divider 11 – reserved	
	3:2	Y8Y9_ST1	11b	Y8, Y9- State0/1definition: 00 – Y8/Y9 disabled to 3-State (PLL4 is in power down) 01 – Y8/Y9 disabled to 3-State (PLL4 on) 10 – Y8/Y9 disabled to low (PLL4 on) 11 – Y8/Y9 enabled (normal operation, PLL4 on)	
1:0	Y8Y9_ST0	01b			
45h	7	Y8Y9_7	0b	Y8Y9_x Output State Selection ⁽⁴⁾ 0 – state0 (predefined by Y8Y9_ST0) 1 – state1 (predefined by Y8Y9_ST1)	
	6	Y8Y9_6	0b		
	5	Y8Y9_5	0b		
	4	Y8Y9_4	0b		
	3	Y8Y9_3	0b		
	2	Y8Y9_2	0b		
	1	Y8Y9_1	1b		
	0	Y8Y9_0	0b		
46h	7	SSC4DC	0b	PLL4 SSC down/center selection: 0 – down 1 – center	
	6:0	Pdiv8	01h	7-Bit Y8-Output-Divider Pdiv8: 0 – reset and stand-by 1-to-127 – divider value	
47h	7	—	0b	Reserved – do not write others than 0	
	6:0	Pdiv9	01h	7-Bit Y9-Output-Divider Pdiv9: 0 – reset and stand-by 1-to-127 – divider value	
48h	7:0	PLL4_ON [11:4]	004h	PLL4_0 ⁽⁵⁾ : 30-Bit Multiplier/Divider value for frequency f_{VCO4_0} (for more information, see PLL Frequency Planning).	
49h	7:4	PLL4_ON [3:0]			
	3:0	PLL4_OR [8:5]	000h		
4Ah	7:3	PLL4_OR[4:0]			
	2:0	PLL4_OQ [5:3]	10h		
4Bh	7:5	PLL4_OQ [2:0]			
	4:2	PLL4_OP [2:0]	010b		
4Ch	7:0	PLL4_1N [11:4]	004h		PLL4_1 ⁽⁵⁾ : 30-Bit Multiplier/Divider value for frequency f_{VCO4_1} (for more information, see PLL Frequency Planning).
	4Dh	7:4			
3:0		PLL4_1R [8:5]	000h		
4Eh	7:3	PLL4_1R[4:0]			
	2:0	PLL4_1Q [5:3]	10h		
4Fh	7:5	PLL4_1Q [2:0]			
	4:2	PLL4_1P [2:0]	010b		
4Fh	1:0	VCO4_1_RANGE	00b	f_{VCO4_1} range selection: 00 – $f_{VCO4_1} < 125$ MHz 01 – $125 \text{ MHz} \leq f_{VCO4_1} < 150$ MHz 10 – $150 \text{ MHz} \leq f_{VCO4_1} < 175$ MHz 11 – $f_{VCO4_1} \geq 175$ MHz	

(1) Writing data beyond 50h may adversely affect device function.

(2) All data is transferred MSB-first.

(3) Unless a custom setting is used

(4) The user can predefine up to eight different control settings. In normal device operation, these settings can be selected by the external control pins, S0, S1, and S2.

(5) PLL settings limits: $16 \leq q \leq 63$, $0 \leq p \leq 7$, $0 \leq r \leq 511$, $0 < N < 4096$

10 Device and Documentation Support

10.1 Device Support

10.1.1 Development Support

For development support see the following:

- [SMBus](#)
- [I²C Bus](#)

10.2 Related Documentation

For related documentation see the following:

[VCXO Application Guideline for CDCE\(L\)9xx Family](#) (SCAA085)

10.3 Related Links

The table below lists quick access links. Categories include technical documents, support and community resources, tools and software, and quick access to sample or buy.

Table 10-1. Related Links

PARTS	PRODUCT FOLDER	SAMPLE & BUY	TECHNICAL DOCUMENTS	TOOLS & SOFTWARE	SUPPORT & COMMUNITY
CDCE949	Click here	Click here	Click here	Click here	Click here
CDCEL949	Click here	Click here	Click here	Click here	Click here

10.4 Receiving Notification of Documentation Updates

To receive notification of documentation updates, navigate to the device product folder on [ti.com](#). Click on *Notifications* to register and receive a weekly digest of any product information that has changed. For change details, review the revision history included in any revised document.

10.5 Support Resources

[TI E2E™ support forums](#) are an engineer's go-to source for fast, verified answers and design help — straight from the experts. Search existing answers or ask your own question to get the quick design help you need.

Linked content is provided "AS IS" by the respective contributors. They do not constitute TI specifications and do not necessarily reflect TI's views; see TI's [Terms of Use](#).

10.6 Trademarks

Ethernet™ is a trademark of Xerox Corporation.

TI-DaVinci™, OMAP™, Pro-Clock™, and TI E2E™ are trademarks of Texas Instruments.

Bluetooth® is a registered trademark of Bluetooth SIG, Inc.

All trademarks are the property of their respective owners.

10.7 Electrostatic Discharge Caution



This integrated circuit can be damaged by ESD. Texas Instruments recommends that all integrated circuits be handled with appropriate precautions. Failure to observe proper handling and installation procedures can cause damage.

ESD damage can range from subtle performance degradation to complete device failure. Precision integrated circuits may be more susceptible to damage because very small parametric changes could cause the device not to meet its published specifications.

10.8 Glossary

[TI Glossary](#) This glossary lists and explains terms, acronyms, and definitions.

11 Revision History

NOTE: Page numbers for previous revisions may differ from page numbers in the current version.

Changes from Revision F (October 2016) to Revision G (January 2024) **Page**

- Changed data sheet title from: *CDCE(L)913: Flexible Low Power LVCMOS Clock Generator With SSC Support for EMI Reduction* to *CDCE(L)949: Flexible Low Power LVCMOS Clock Generator With SSC Support for EMI Reduction* 1
 - Updated the numbering format for tables, figures, and cross-references throughout the document..... 1
 - Changed all instances of legacy terminology to controller and target where I²C is mentioned..... 1
 - Changed the *Device Information* table to *Package Information* 1
-

Changes from Revision E (August 2016) to Revision F (October 2016) **Page**

- Changed data sheet title from: *CDCEx949 Programmable 4-PLL VCXO Clock Synthesizer With 1.8-V, 2.5-V, and 3.3-V LVCMOS Outputs* to: *CDCE(L)913: Flexible Low Power LVCMOS Clock Generator With SSC Support for EMI Reduction* 1
-

Changes from Revision D (March 2010) to Revision E (August 2016) **Page**

- Added *Device Information* table, *ESD Ratings* table, *Feature Description* section, *Device Functional Modes, Application and Implementation* section, *Power Supply Recommendations* section, *Layout* section, *Device and Documentation Support* section, and *Mechanical, Packaging, and Orderable Information* section..... 1
 - Condensed down bullets in *Features* 1
 - Deleted 'General Purpose Frequency Synthesizing' from *Applications* 1
 - Updated values in the *Thermal Information* table to align with JEDEC standards 6
 - Changed Byte Read Protocol image, second S to Sr..... 17
 - Changed 100 MHz < f_{VCO} > 200 MHz; TO 80 MHz $\leq f_{VCO} \leq$ 230 MHz; and changed $0 \leq p \leq 7$ TO $0 \leq p \leq 4$ 20
 - Changed under Example, fifth row, N", 2 places TO N'..... 20
-

Changes from Revision C (October 2009) to Revision D () **Page**

- Added PLL settings limits: $16 \leq q \leq 63$, $0 \leq p \leq 7$, $0 \leq r \leq 511$, $0 < N < 4096$ foot to PLL1, PLL2, PLL3, & PLL4 Configure Register Table..... 25
-

Changes from Revision B (September 2009) to Revision C () **Page**

- Deleted sentence - A different default setting can be programmed on customer request. Contact Texas Instruments sales or marketing representative for more information..... 14
-

Changes from Revision A (December 2007) to Revision B () **Page**

- Added Note 3: SDA and SCL can go up to 3.6 V as stated in the *Recommended Operating Conditions* table. 5
-

Changes from Revision * (August 2007) to Revision A () **Page**

- Changed the THERMAL RESISTANCE FOR TSSOP table..... 6
 - Changed *Generic Configuration Register* table RID From: 0h To: Xb..... 25
 - Added note to the PWDN description, *Generic Configuration Register* table..... 25
-

12 Mechanical, Packaging, and Orderable Information

The following pages include mechanical, packaging, and orderable information. This information is the most current data available for the designated devices. This data is subject to change without notice and revision of this document. For browser-based versions of this data sheet, refer to the left-hand navigation.

PACKAGING INFORMATION

Orderable Device	Status (1)	Package Type	Package Drawing	Pins	Package Qty	Eco Plan (2)	Lead finish/ Ball material (6)	MSL Peak Temp (3)	Op Temp (°C)	Device Marking (4/5)	Samples
CDCE949PW	ACTIVE	TSSOP	PW	24	60	RoHS & Green	NIPDAU	Level-1-260C-UNLIM	-40 to 85	CDCE949	Samples
CDCE949PWG4	ACTIVE	TSSOP	PW	24	60	RoHS & Green	NIPDAU	Level-1-260C-UNLIM	-40 to 85	CDCE949	Samples
CDCE949PWR	ACTIVE	TSSOP	PW	24	2000	RoHS & Green	NIPDAU	Level-1-260C-UNLIM	-40 to 85	CDCE949	Samples
CDCEL949PW	ACTIVE	TSSOP	PW	24	60	RoHS & Green	NIPDAU	Level-1-260C-UNLIM	-40 to 85	CDCEL949	Samples
CDCEL949PWR	ACTIVE	TSSOP	PW	24	2000	RoHS & Green	NIPDAU	Level-1-260C-UNLIM	-40 to 85	CDCEL949	Samples

(1) The marketing status values are defined as follows:

ACTIVE: Product device recommended for new designs.

LIFEBUY: TI has announced that the device will be discontinued, and a lifetime-buy period is in effect.

NRND: Not recommended for new designs. Device is in production to support existing customers, but TI does not recommend using this part in a new design.

PREVIEW: Device has been announced but is not in production. Samples may or may not be available.

OBsolete: TI has discontinued the production of the device.

(2) **RoHS:** TI defines "RoHS" to mean semiconductor products that are compliant with the current EU RoHS requirements for all 10 RoHS substances, including the requirement that RoHS substance do not exceed 0.1% by weight in homogeneous materials. Where designed to be soldered at high temperatures, "RoHS" products are suitable for use in specified lead-free processes. TI may reference these types of products as "Pb-Free".

RoHS Exempt: TI defines "RoHS Exempt" to mean products that contain lead but are compliant with EU RoHS pursuant to a specific EU RoHS exemption.

Green: TI defines "Green" to mean the content of Chlorine (Cl) and Bromine (Br) based flame retardants meet JS709B low halogen requirements of <=1000ppm threshold. Antimony trioxide based flame retardants must also meet the <=1000ppm threshold requirement.

(3) MSL, Peak Temp. - The Moisture Sensitivity Level rating according to the JEDEC industry standard classifications, and peak solder temperature.

(4) There may be additional marking, which relates to the logo, the lot trace code information, or the environmental category on the device.

(5) Multiple Device Markings will be inside parentheses. Only one Device Marking contained in parentheses and separated by a "~" will appear on a device. If a line is indented then it is a continuation of the previous line and the two combined represent the entire Device Marking for that device.

(6) Lead finish/Ball material - Orderable Devices may have multiple material finish options. Finish options are separated by a vertical ruled line. Lead finish/Ball material values may wrap to two lines if the finish value exceeds the maximum column width.

Important Information and Disclaimer:The information provided on this page represents TI's knowledge and belief as of the date that it is provided. TI bases its knowledge and belief on information provided by third parties, and makes no representation or warranty as to the accuracy of such information. Efforts are underway to better integrate information from third parties. TI has taken and continues to take reasonable steps to provide representative and accurate information but may not have conducted destructive testing or chemical analysis on incoming materials and chemicals. TI and TI suppliers consider certain information to be proprietary, and thus CAS numbers and other limited information may not be available for release.

In no event shall TI's liability arising out of such information exceed the total purchase price of the TI part(s) at issue in this document sold by TI to Customer on an annual basis.

OTHER QUALIFIED VERSIONS OF CDCE949 :

- Automotive : [CDCE949-Q1](#)

NOTE: Qualified Version Definitions:

- Automotive - Q100 devices qualified for high-reliability automotive applications targeting zero defects

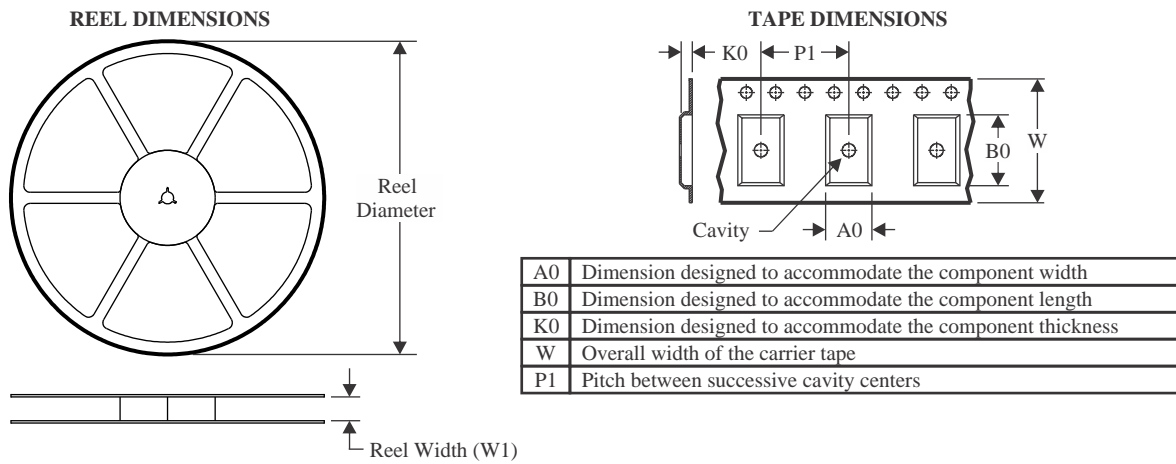
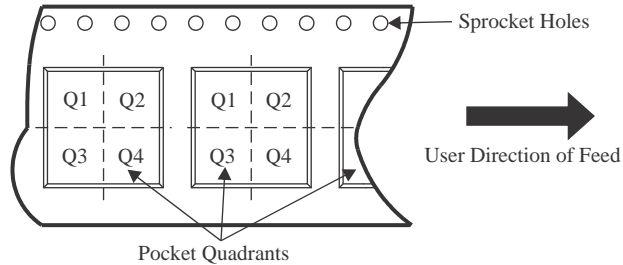
TAPE AND REEL INFORMATION

QUADRANT ASSIGNMENTS FOR PIN 1 ORIENTATION IN TAPE

*All dimensions are nominal

Device	Package Type	Package Drawing	Pins	SPQ	Reel Diameter (mm)	Reel Width W1 (mm)	A0 (mm)	B0 (mm)	K0 (mm)	P1 (mm)	W (mm)	Pin1 Quadrant
CDCE949PWR	TSSOP	PW	24	2000	330.0	16.4	6.95	8.3	1.6	8.0	16.0	Q1
CDCEL949PWR	TSSOP	PW	24	2000	330.0	16.4	6.95	8.3	1.6	8.0	16.0	Q1

TAPE AND REEL BOX DIMENSIONS

*All dimensions are nominal

Device	Package Type	Package Drawing	Pins	SPQ	Length (mm)	Width (mm)	Height (mm)
CDCE949PWR	TSSOP	PW	24	2000	356.0	356.0	35.0
CDCEL949PWR	TSSOP	PW	24	2000	356.0	356.0	35.0

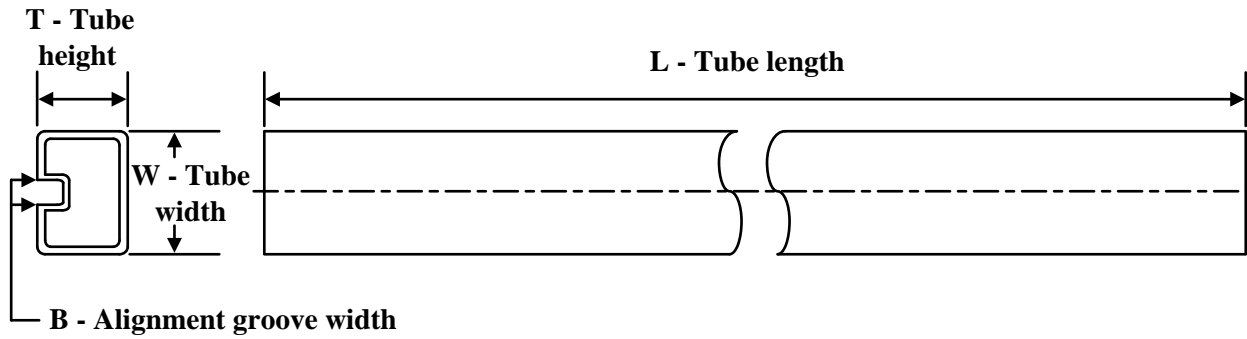
TUBE

*All dimensions are nominal

Device	Package Name	Package Type	Pins	SPQ	L (mm)	W (mm)	T (μm)	B (mm)
CDCE949PW	PW	TSSOP	24	60	530	10.2	3600	3.5
CDCE949PWG4	PW	TSSOP	24	60	530	10.2	3600	3.5
CDCEL949PW	PW	TSSOP	24	60	530	10.2	3600	3.5

PW0024A

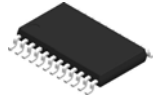

PACKAGE OUTLINE

TSSOP - 1.2 mm max height

SMALL OUTLINE PACKAGE

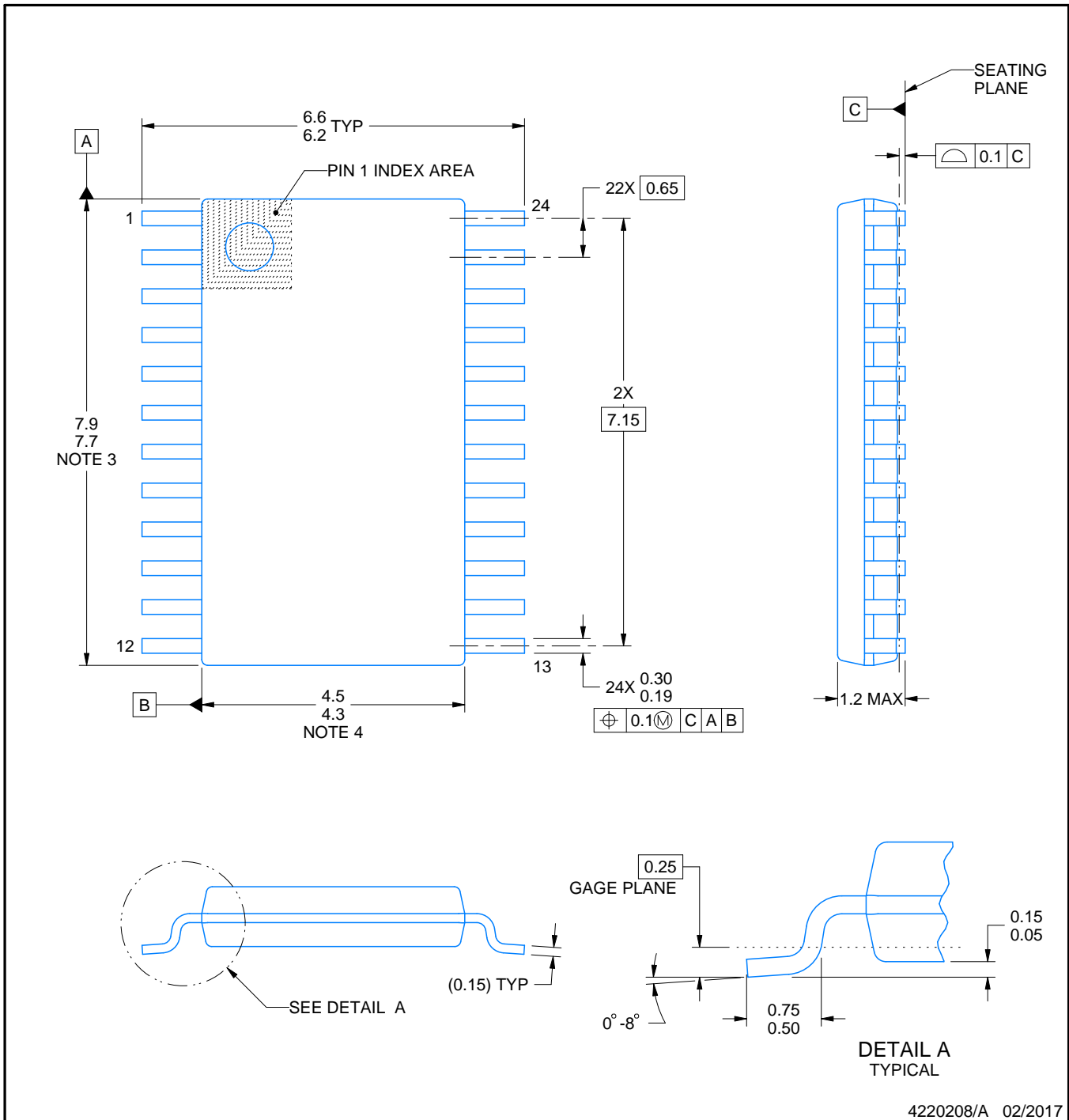

4220208/A 02/2017

NOTES:

1. All linear dimensions are in millimeters. Any dimensions in parenthesis are for reference only. Dimensioning and tolerancing per ASME Y14.5M.
2. This drawing is subject to change without notice.
3. This dimension does not include mold flash, protrusions, or gate burrs. Mold flash, protrusions, or gate burrs shall not exceed 0.15 mm per side.
4. This dimension does not include interlead flash. Interlead flash shall not exceed 0.25 mm per side.
5. Reference JEDEC registration MO-153.

EXAMPLE BOARD LAYOUT

PW0024A

TSSOP - 1.2 mm max height

SMALL OUTLINE PACKAGE

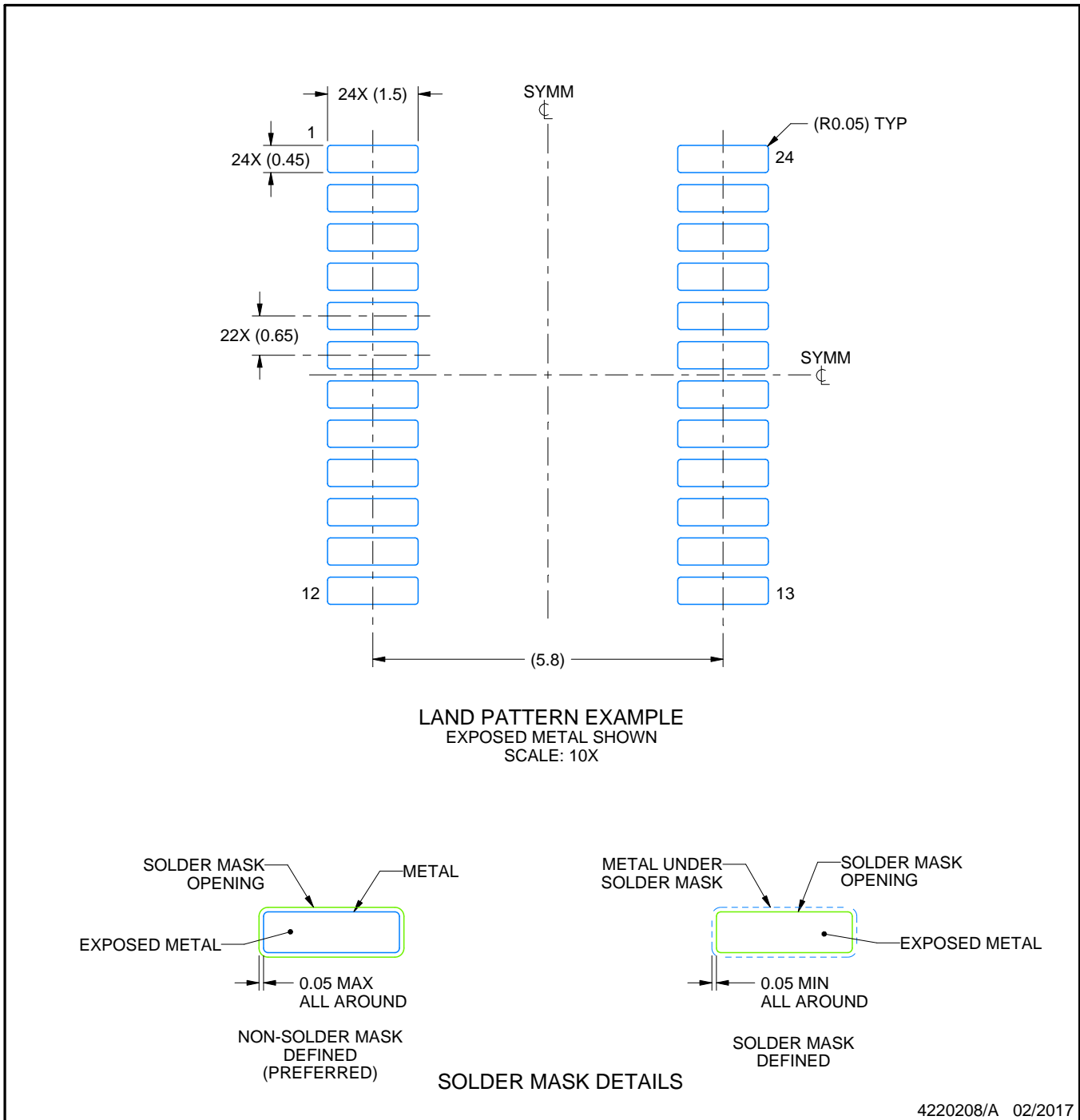

NOTES: (continued)

- 6. Publication IPC-7351 may have alternate designs.
- 7. Solder mask tolerances between and around signal pads can vary based on board fabrication site.

EXAMPLE STENCIL DESIGN

PW0024A

TSSOP - 1.2 mm max height

SMALL OUTLINE PACKAGE

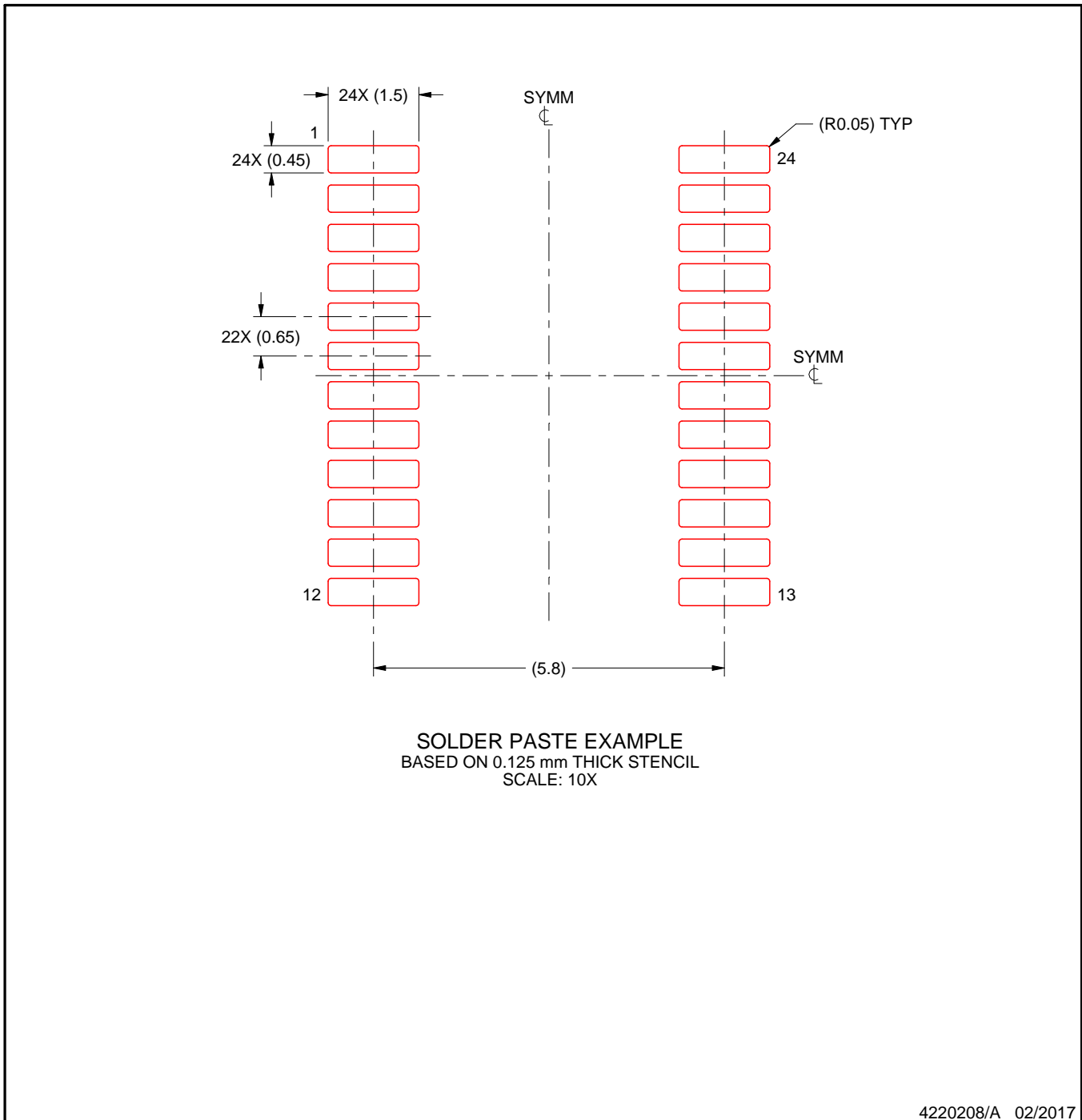

NOTES: (continued)

8. Laser cutting apertures with trapezoidal walls and rounded corners may offer better paste release. IPC-7525 may have alternate design recommendations.
9. Board assembly site may have different recommendations for stencil design.

IMPORTANT NOTICE AND DISCLAIMER

TI PROVIDES TECHNICAL AND RELIABILITY DATA (INCLUDING DATA SHEETS), DESIGN RESOURCES (INCLUDING REFERENCE DESIGNS), APPLICATION OR OTHER DESIGN ADVICE, WEB TOOLS, SAFETY INFORMATION, AND OTHER RESOURCES "AS IS" AND WITH ALL FAULTS, AND DISCLAIMS ALL WARRANTIES, EXPRESS AND IMPLIED, INCLUDING WITHOUT LIMITATION ANY IMPLIED WARRANTIES OF MERCHANTABILITY, FITNESS FOR A PARTICULAR PURPOSE OR NON-INFRINGEMENT OF THIRD PARTY INTELLECTUAL PROPERTY RIGHTS.

These resources are intended for skilled developers designing with TI products. You are solely responsible for (1) selecting the appropriate TI products for your application, (2) designing, validating and testing your application, and (3) ensuring your application meets applicable standards, and any other safety, security, regulatory or other requirements.

These resources are subject to change without notice. TI grants you permission to use these resources only for development of an application that uses the TI products described in the resource. Other reproduction and display of these resources is prohibited. No license is granted to any other TI intellectual property right or to any third party intellectual property right. TI disclaims responsibility for, and you will fully indemnify TI and its representatives against, any claims, damages, costs, losses, and liabilities arising out of your use of these resources.

TI's products are provided subject to [TI's Terms of Sale](#) or other applicable terms available either on [ti.com](https://www.ti.com) or provided in conjunction with such TI products. TI's provision of these resources does not expand or otherwise alter TI's applicable warranties or warranty disclaimers for TI products.

TI objects to and rejects any additional or different terms you may have proposed.

Mailing Address: Texas Instruments, Post Office Box 655303, Dallas, Texas 75265
Copyright © 2024, Texas Instruments Incorporated

Looking for pricing, stock, or lifecycle information?

Click below to explore more details on WIN SOURCE:

 [View CDCE949PWR](#) on WIN SOURCE

 [Texas Instruments](#) Information

Optimize Your Supply Chain with WIN SOURCE Solutions

-  Global Sourcing Solution
-  Obsolete Management
-  Cost Control Management
-  Shortage Management
-  Alternative Solution
-  Excess Inventory Management