



**THE DATASHEET OF  
PL502-04SC-R**



## Low Phase Noise VCXO (96MHz to 200MHz)

### FEATURES

- Low phase noise VCXO output for the 96MHz to 200MHz range (-128 dBc at 10kHz offset)
- LVCMOS output
- 12 to 25MHz crystal input
- Integrated variable capacitors
- Selectable High Drive (30mA) or Standard Drive (10mA) output
- Wide pull range ( $\pm 250$  ppm typ)
- Low period jitter: 4ps RMS
- 3.3V operation
- Available in 8-Pin SOP

### DESCRIPTION

The PL502-04 is a low cost, high performance, low phase noise VCXO, providing less than -128dBc at 10kHz offset in the 96MHz to 200MHz operating range. The very low jitter (4 ps RMS period jitter) makes this chip ideal for applications requiring voltage controlled frequency sources. Input crystal can range from 12MHz to 25MHz (fundamental resonant mode).

### PIN CONFIGURATION

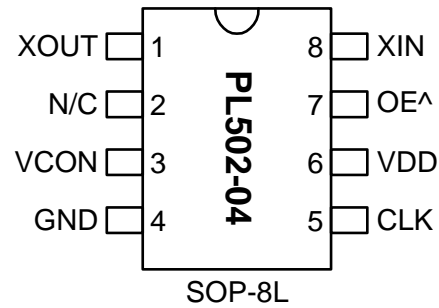

### OUTPUT RANGE

MULTIPLIER	FREQUENCY RANGE	OUTPUT BUFFER
X8	96 - 200MHz	LVCMOS

### BLOCK DIAGRAM

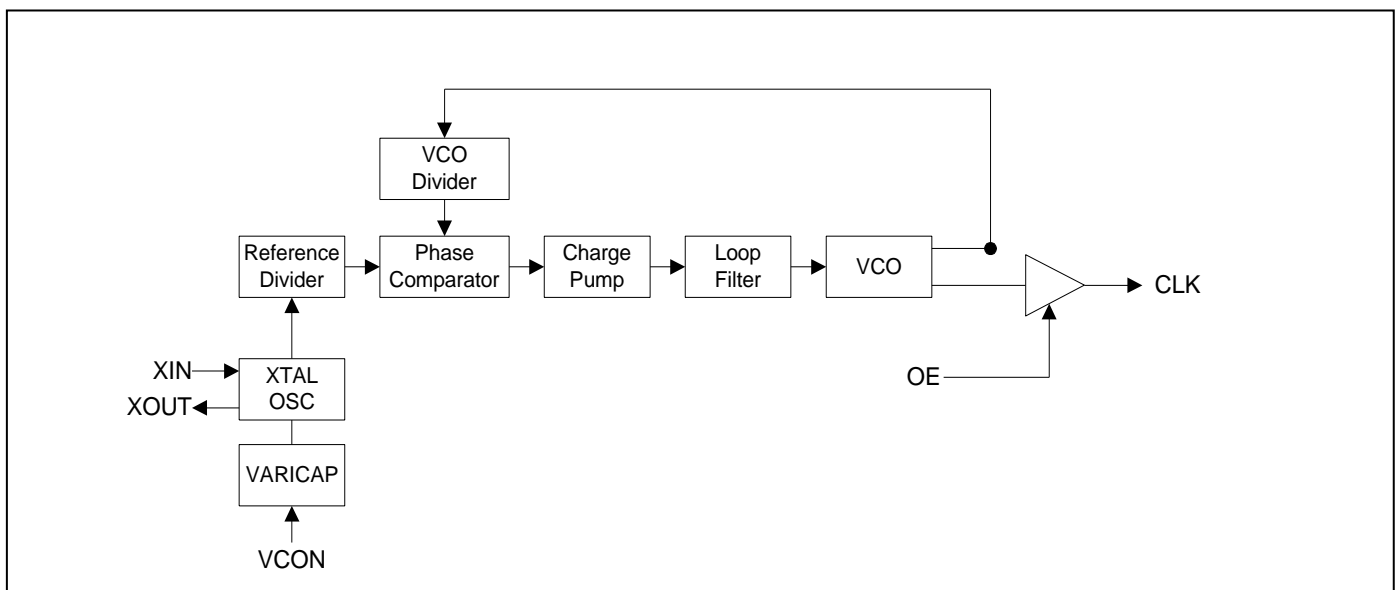

**Low Phase Noise VCXO (96MHz to 200MHz)**
**PIN DESCRIPTIONS**

Name	Number	Type	Description
XOUT	1	I	Crystal output. See Crystal Specifications on page 4.
N/C	2	-	Not connected.
VCON	3	I	Voltage Control input.
GND	4	P	Ground.
CLK	5	O	Output clock.
VDD	6	P	+3.3V power supply.
OE	7	I	Output Enable. Internal Pull Up.
XIN	8	I	Crystal input. See Crystal Specifications on page 4.

**ELECTRICAL SPECIFICATIONS**
**1. Absolute Maximum Ratings**

PARAMETERS	SYMBOL	MIN.	MAX.	UNITS
Supply Voltage	$V_{DD}$		4.6	V
Input Voltage, dc	$V_I$	-0.5	$V_{DD}+0.5$	V
Output Voltage, dc	$V_O$	-0.5	$V_{DD}+0.5$	V
Storage Temperature	$T_S$	-65	150	°C
Ambient Operating Temperature*	$T_A$	-40	85	°C
Junction Temperature	$T_J$		125	°C
Lead Temperature (soldering, 10s)			260	°C
ESD Protection, Human Body Model			2	kV

Exposure of the device under conditions beyond the limits specified by Maximum Ratings for extended periods may cause permanent damage to the device and affect product reliability. These conditions represent a stress rating only, and functional operations of the device at these or any other conditions above the operational limits noted in this specification is not implied. **Note:** Operating Temperature is guaranteed by design for all parts (COMMERCIAL and INDUSTRIAL), but tested for COMMERCIAL grade only.

**2. AC Electrical Specifications**

PARAMETERS	SYMBOL	CONDITIONS	MIN.	TYP.	MAX.	UNITS
Input Crystal Frequency			12		25	MHz
Output Clock Rise/Fall Time (Standard Drive)	$t_r/t_f$	0.3V ~ 3.0V, 15 pF load		2.4		ns
Output Clock Rise/Fall Time (High Drive)	$t_r/t_f$	0.3V ~ 3.0V, 15 pF load		1.2		
Output Clock Duty Cycle		Measured @ 50% $V_{DD}$	45	50	55	%

**Low Phase Noise VCXO (96MHz to 200MHz)**
**3. DC Specifications**

PARAMETERS	SYMBOL	CONDITIONS	MIN.	TYP.	MAX.	UNITS
Supply Current, Dynamic, with Loaded Outputs	$I_{DD}$	$F_{XIN} = 25\text{MHz}$ Output load 10pF		20	25	mA
Operating Voltage	$V_{DD}$		2.97		3.63	V
Output Drive Current (High Drive)	$I_{OH}$	$V_{OH} = V_{DD} - 0.4\text{V}$ , $V_{DD} = 3.3\text{V}$	30			mA
	$I_{OL}$	$V_{OL} = 0.4\text{V}$ , $V_{DD} = 3.3\text{V}$	30			mA
Output Drive Current (Standard Drive)	$I_{OH}$	$V_{OH} = V_{DD} - 0.4\text{V}$ , $V_{DD} = 3.3\text{V}$	10			mA
	$I_{OL}$	$V_{OL} = 0.4\text{V}$ , $V_{DD} = 3.3\text{V}$	10			mA
Short Circuit Current				±50		mA
VCXO Control Voltage	VCON		0		3.3	V

**4. Voltage Control Crystal Oscillator**

PARAMETERS	SYMBOL	CONDITIONS	MIN.	TYP.	MAX.	UNITS
VCXO Stabilization Time *	$T_{VCXOSTB}$	From power valid			10	ms
VCXO Tuning Range		$F_{XIN} = 12 - 25\text{MHz}$ ; XTAL $C_0/C_1 < 250$ $0\text{V} \leq \text{VCON} \leq 3.3\text{V}$		500		ppm
CLK output pullability		$\text{VCON} = 1.65\text{V}$ , ±1.65V	±200			ppm
VCXO Tuning Characteristic				165		ppm/V
Pull range linearity					10	%
VCON pin input impedance			2000			kΩ
VCON modulation BW		$0\text{V} \leq \text{VCON} \leq 3.3\text{V}$ , -3dB	10			kHz

**Note:** Parameters denoted with an asterisk (\*) represent nominal characterization data and are not production tested to any specific limits.

**5. Jitter and Phase Noise Specification**

PARAMETERS	CONDITIONS	MIN.	TYP.	MAX.	UNITS
RMS Period Jitter (1 sigma – 1000 samples)	At 155MHz with capacitive decoupling between VDD and GND.		4		ps
Phase Noise relative to carrier	155.52MHz @100Hz offset		-95		dBc/Hz
Phase Noise relative to carrier	155.52MHz @1kHz offset		-120		dBc/Hz
Phase Noise relative to carrier	155.52MHz @10kHz offset		-128		dBc/Hz
Phase Noise relative to carrier	155.52MHz @100kHz offset		-122		dBc/Hz
Phase Noise relative to carrier	155.52MHz @1MHz offset		-120		dBc/Hz

## Low Phase Noise VCXO (96MHz to 200MHz)

### 6. Crystal Specifications

PARAMETERS	SYMBOL	MIN.	TYP.	MAX.	UNITS
Crystal Resonator Frequency	$F_{XIN}$	12		25	MHz
Crystal Loading Capacitance Rating	$C_{L(xtal)}$		9.5		pF
C0/C1				250	-
ESR	$R_S$			30	$\Omega$

**Note:** Crystal Loading rating: 9.5pF is the loading the crystal sees from the VCXO chip at  $V_{CON} = 1.65V$ . It is assumed that the crystal will be at nominal frequency at this load. If the crystal requires more load to be at nominal frequency, the additional load must be added externally. This however may reduce the pull range.

### PACKAGE INFORMATION (GREEN PACKAGE COMPLIANT)

8 PIN SOP (in mm)		
Symbol	Min.	Max.
A	1.47	1.73
A1	0.10	0.25
B	0.33	0.51
C	0.19	0.25
D	4.80	4.95
E	3.80	4.00
H	5.80	6.20
L	0.38	1.27
e	1.27 BSC	

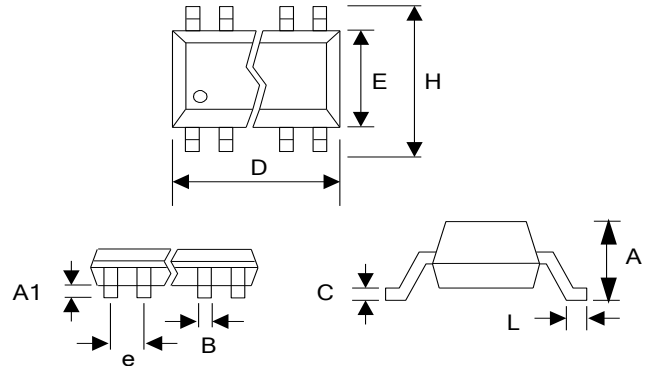

## Low Phase Noise VCXO (96MHz to 200MHz)

### ORDERING INFORMATION (GREEN PACKAGE COMPLIANT)

**For part ordering, please contact our Sales Department:**

2180 Fortune Drive, San Jose, CA 95131, USA

Tel: (408) 944-0800 Fax: (408) 474-1000

#### PART NUMBER

The order number for this device is a combination of the following:  
Part number, Package type and Operating temperature range

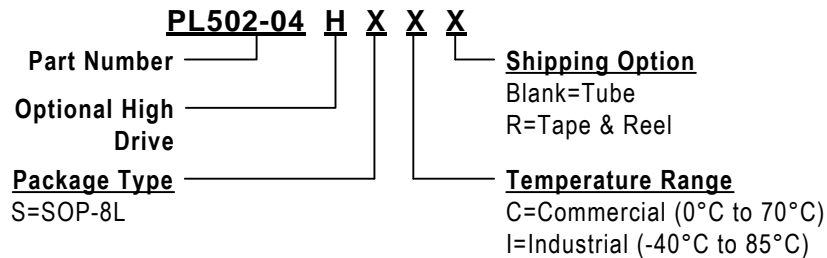

Part/Order Number	Marking	Package Option
PL502-04SC	P502-04 SC	SOP - Tube
PL502-04SC-R	LLLLL	SOP - Tape and Reel
PL502-04HSC	P502-04H SC	SOP - Tube
PL502-04HSC-R	LLLLL	SOP - Tape and Reel



\*Note: "LLL" or "LLLLL" are designates lot number

Micrel Inc., reserves the right to make changes in its products or specifications, or both at any time without notice. The information furnished by Micrel is believed to be accurate and reliable. However, Micrel makes no guarantee or warranty concerning the accuracy of said information and shall not be responsible for any loss or damage of whatever nature resulting from the use of, or reliance upon this product.

**LIFE SUPPORT POLICY:** Micrel's products are not authorized for use as critical components in life support devices or systems without the express written approval of the President of Micrel Inc.

## Looking for pricing, stock, or lifecycle information?

Click below to explore more details on WIN SOURCE:

-  [View PL502-04SC-R on WIN SOURCE](#)
-  [Microchip Technology](#) Information

## Optimize Your Supply Chain with WIN SOURCE Solutions

-  Global Sourcing Solution
-  Obsolete Management
-  Cost Control Management
-  Shortage Management
-  Alternative Solution
-  Excess Inventory Management