

2.5-V PHASE-LOCKED-LOOP CLOCK DRIVER

FEATURES

- Spread-Spectrum Clock Compatible
- Operating Frequency: 60 MHz to 220 MHz
- Low Jitter (Cycle-Cycle): ± 35 ps
- Low Static Phase Offset: ± 50 ps
- Low Jitter (Period): ± 30 ps
- 1-to-10 Differential Clock Distribution (SSTL2)
- Best in Class for $V_{OX} = V_{DD}/2 \pm 0.1$ V
- Operates From Dual 2.6-V or 2.5-V Supplies
- Available in a 40-Pin MLF Package, 48-Pin TSSOP Package, 56-Ball MicroStar Junior™ BGA Package
- Consumes < 100- μ A Quiescent Current
- External Feedback Pins (FBIN, $\overline{\text{FBIN}}$) Are Used to Synchronize the Outputs to the Input Clocks
- Meets/Exceeds JEDEC Standard (JESD82-1) For DDRI-200/266/333 Specification
- Meets/Exceeds Proposed DDRI-400 Specification (JESD82-1A)
- Enters Low-Power Mode When No CLK Input Signal Is Applied or PWRDWN Is Low

APPLICATIONS

- DDR Memory Modules (DDR400/333/266/200)
- Zero-Delay Fan-Out Buffer

DESCRIPTION

The CDCVF857 is a high-performance, low-skew, low-jitter, zero-delay buffer that distributes a differential clock input pair (CLK, $\overline{\text{CLK}}$) to 10 differential pairs of clock outputs (Y[0:9], $\overline{\text{Y}}[0:9]$) and one differential pair of feedback clock outputs (FBOUT, $\overline{\text{FBOUT}}$). The clock outputs are controlled by the clock inputs (CLK, $\overline{\text{CLK}}$), the feedback clocks (FBIN, $\overline{\text{FBIN}}$), and the analog power input (AVDD). When PWRDWN is high, the outputs switch in phase and frequency with CLK. When $\overline{\text{PWRDWN}}$ is low, all outputs are disabled to a high-impedance state (3-state) and the PLL is shut down (low-power mode). The device also enters this low-power mode when the input frequency falls below a suggested detection frequency that is below 20 MHz (typical 10 MHz). An input frequency detection circuit detects the low frequency condition and, after applying a >20-MHz input signal, this detection circuit turns the PLL on and enables the outputs.

When AV_{DD} is strapped low, the PLL is turned off and bypassed for test purposes. The CDCVF857 is also able to track spread spectrum clocking for reduced EMI.

Because the CDCVF857 is based on PLL circuitry, it requires a stabilization time to achieve phase-lock of the PLL. This stabilization time is required following power up. The CDCVF857 is characterized for both commercial and industrial temperature ranges.

AVAILABLE OPTIONS

T _A	TSSOP (DGG)	40-Pin MLF	56-Ball BGA ⁽¹⁾
-40°C to 85°C	CDCVF857DGG	CDCVF857RTB	CDCVF857GQL
-40°C to 85°C		CDCVF857RHA	CDCVF857ZQL

(1) Maximum load recommended is 12 pf for 200 MHz. At 12-pf load, maximum T_A allowed is 70°C.



Please be aware that an important notice concerning availability, standard warranty, and use in critical applications of Texas Instruments semiconductor products and disclaimers thereto appears at the end of this data sheet.

MicroStar Junior is a trademark of Texas Instruments.

**FUNCTION TABLE
(Select Functions)**

INPUTS				OUTPUTS				PLL
AVDD	PWRDWN	CLK	CLK	Y[0:9]	Y[0:9]	FBOU	FBOU	
GND	H	L	H	L	H	L	H	Bypassed/off
GND	H	H	L	H	L	H	L	Bypassed/off
X	L	L	H	Z	Z	Z	Z	Off
X	L	H	L	Z	Z	Z	Z	Off
2.5 V (nom)	H	L	H	L	H	L	H	On
2.5 V (nom)	H	H	L	H	L	H	L	On
2.5 V (nom)	X	<20 MHz	<20 MHz	Z	Z	Z	Z	Off

DGG PACKAGE
(TOP VIEW)

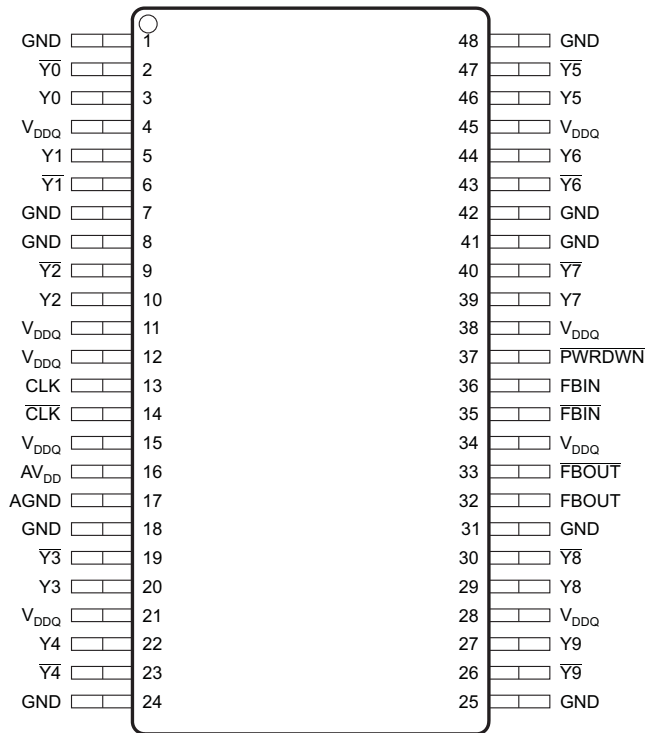

P0052-01

RHA/RTB PACKAGE
(TOP VIEW)

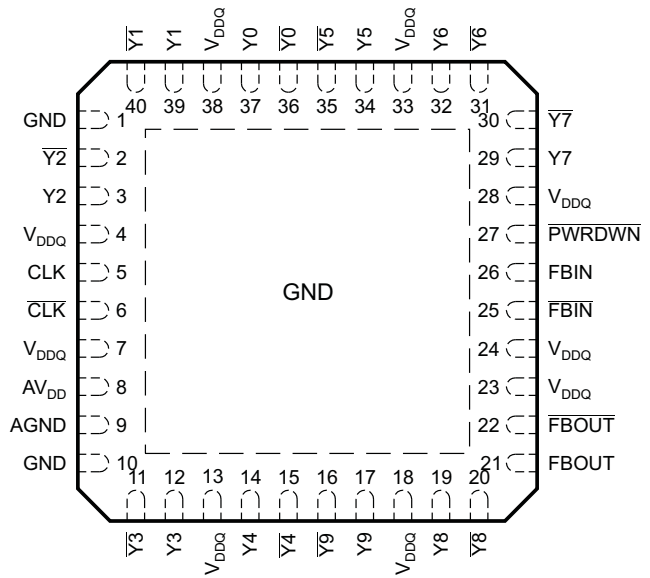

P0053-01

MicroStar Junior™ BGA (GQL/ZQL) PACKAGE
(TOP VIEW)

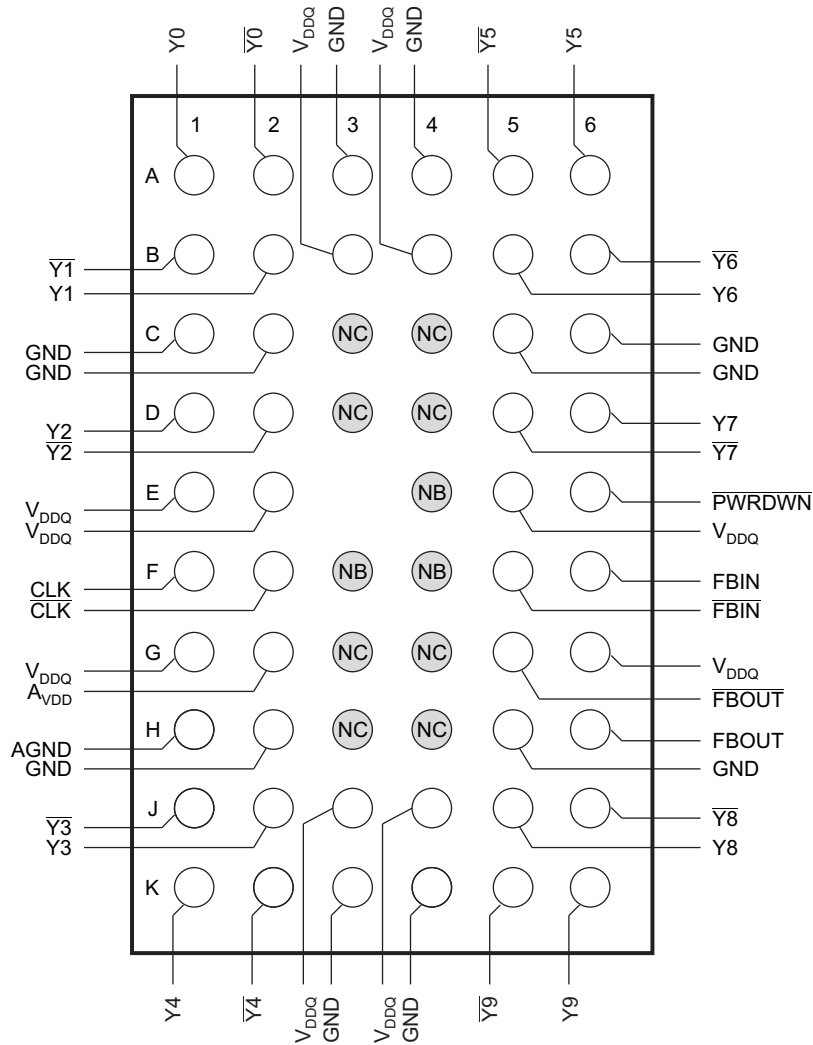

NB = No Ball
 NC = No Connection

P0054-01

FUNCTIONAL BLOCK DIAGRAM

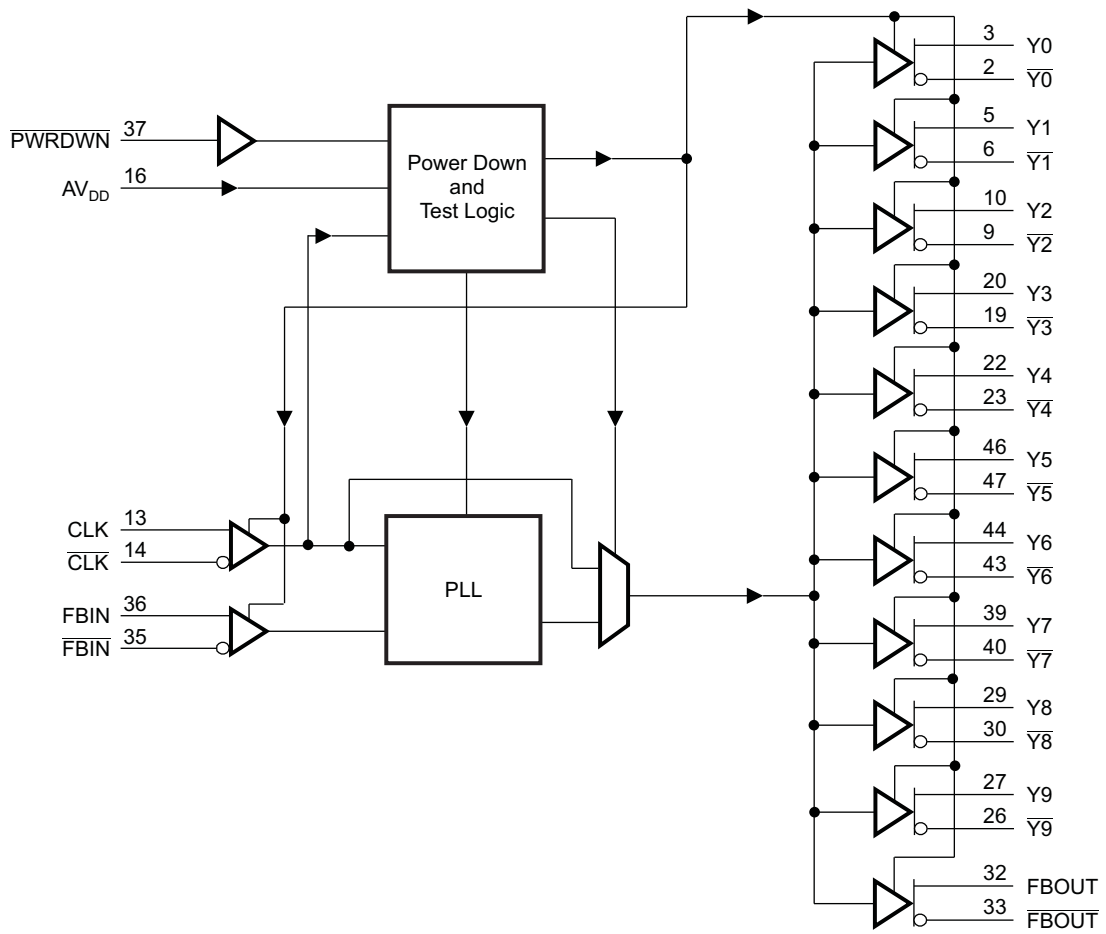

B0196-01

Table 1. TERMINAL FUNCTIONS

TERMINAL				I/O	DESCRIPTION
NAME	DGG	RHA/RTB	GQL/ZQL		
AGND	17	9	H1	–	Ground for 2.5-V analog supply
AV _{DD}	16	8	G2	–	2.5-V analog supply
CLK, $\overline{\text{CLK}}$	13, 14	5, 6	F1, F2	I	Differential clock input
FBIN, FBIN	35, 36	25, 26	F5, F6	I	Feedback differential clock input
FBOU _T , FBOU _T	32, 33	21, 22	H6, G5	O	Feedback differential clock output
GND	1, 7, 8, 18, 24, 25, 31, 41, 42, 48	1, 10	A3, A4, C1, C2, C5, C6, H2, H5, K3, K4	–	Ground
PWRDWN	37	27	E6	I	Output enable for Y and $\overline{\text{Y}}$
V _{DDQ}	4, 11, 12, 15, 21, 28, 34, 38, 45	4, 7, 13, 18, 23, 24, 28, 33, 38	B3, B4, E1, E2, E5, G1, G6, J3, J4	–	2.5-V supply
Y0, $\overline{\text{Y0}}$	3, 2	37, 36	A1, A2	O	Buffered output copies of input clock, CLK, $\overline{\text{CLK}}$
Y1, $\overline{\text{Y1}}$	5, 6	39, 40	B2, B1	O	
Y2, $\overline{\text{Y2}}$	10, 9	3, 2	D1, D2	O	
Y3, $\overline{\text{Y3}}$	20, 19	12, 11	J2, J1	O	
Y4, $\overline{\text{Y4}}$	22, 23	14, 15	K1, K2	O	
Y5, $\overline{\text{Y5}}$	46, 47	34, 35	A6, A5	O	
Y6, $\overline{\text{Y6}}$	44, 43	32, 31	B5, B6	O	
Y7, $\overline{\text{Y7}}$	39, 40	29, 30	D6, D5	O	
Y8, $\overline{\text{Y8}}$	29, 30	19, 20	J5, J6	O	
Y9, $\overline{\text{Y9}}$	27, 26	17, 16	K6, K5	O	

ABSOLUTE MAXIMUM RATINGS

over operating free-air temperature range (unless otherwise noted) ⁽¹⁾

V _{DDQ} , AV _{DD}	Supply voltage range		0.5 V to 3.6 V
V _I	Input voltage range ⁽²⁾⁽³⁾		–0.5 V to V _{DDQ} + 0.5 V
V _O	Output voltage range ⁽²⁾⁽³⁾		–0.5 V to V _{DDQ} + 0.5 V
I _{IK}	Input clamp current	V _I < 0 or V _I > V _{DDQ}	±50 mA
I _{OK}	Output clamp current	V _O < 0 or V _O > V _{DDQ}	±50 mA
I _O	Continuous output current	V _O = 0 to V _{DDQ}	±50 mA
I _{DDC}	Continuous current to GND or V _{DDQ}		±100 mA
T _{stg}	Storage temperature range		–65°C to 150°C

- (1) Stresses beyond those listed under "absolute maximum ratings" may cause permanent damage to the device. These are stress ratings only, and functional operation of the device at these or any other conditions beyond those indicated under "recommended operating conditions" is not implied. Exposure to absolute-maximum-rated conditions for extended periods may affect device reliability.
- (2) The input and output negative voltage ratings may be exceeded if the input and output clamp current ratings are observed.
- (3) This value is limited to 3.6 V maximum.

THERMAL CHARACTERISTICS

R _{θJA} for TSSOP (DGG) Package ⁽¹⁾			R _{θJA} for MLF (RHA/RTB) Package		R _{θJA} for BGA (GQL/ZQL) Package ⁽²⁾	
Airflow	Low K	High K	Airflow	With 4 Thermal Vias	Airflow	High K
0 ft/min	89.1°C/W	70°C/W	0 ft/min	44.7°C/W	0 ft/min	132.2°C/W
150 ft/min	78.5°C/W	65.3°C/W	150 ft/min		150 ft/min	126.4°C/W

- (1) The package thermal impedance is calculated in accordance with JESD 51.
- (2) Connecting the NC-balls (C3, C4, D3, D4, G3, G4, H3, H4) to a ground plane improves the θ_{JA} to 114.8°C/W (0 airflow).

RECOMMENDED OPERATING CONDITIONS

			MIN	NOM	MAX	UNIT
Supply voltage	V _{DDQ}	PC1600 – PC3200	2.3		2.7	V
	AVDD		V _{DDQ} – 0.12		2.7	
V _{IL} Low-level input voltage	CLK, $\overline{\text{CLK}}$, FBIN, $\overline{\text{FBIN}}$				V _{DDQ} /2 – 0.18	V
	PWRDWN		–0.3		0.7	
V _{IH} High-level input voltage	CLK, $\overline{\text{CLK}}$, FBIN, $\overline{\text{FBIN}}$		V _{DDQ} /2 + 0.18			V
	PWRDWN		1.7		V _{DDQ} + 0.3	
DC input signal voltage ⁽¹⁾			–0.3		V _{DDQ} + 0.3	V
V _{ID} Differential input signal voltage ⁽²⁾	DC	CLK, FBIN	0.36		V _{DDQ} + 0.6	V
	AC	CLK, FBIN	0.7		V _{DDQ} + 0.6	
V _{IX} Input differential pair cross voltage ⁽³⁾⁽⁴⁾			V _{DDQ} /2 – 0.2		V _{DDQ} /2 + 0.2	V
I _{OH} High-level output current					–12	mA
I _{OL} Low-level output current					12	mA
SR Input slew rate			1		4	V/ns
T _A Operating free-air temperature			–40		85	°C

- (1) The unused inputs must be held high or low to prevent them from floating.
- (2) The dc input signal voltage specifies the allowable dc execution of the differential input.
- (3) The differential input signal voltage specifies the differential voltage |VTR – VCP| required for switching, where VTR is the true input level and VCP is the complementary input level.
- (4) The differential cross-point voltage tracks variations of V_{CC} and is the voltage at which the differential signals must cross.

ELECTRICAL CHARACTERISTICS

over recommended operating free-air temperature range (unless otherwise noted)

PARAMETER	TEST CONDITIONS	MIN	TYP ⁽¹⁾	MAX	UNIT
V _{IK} Input voltage, all inputs	V _{DDQ} = 2.3 V, I _I = –18 mA			–1.2	V
V _{OH} High-level output voltage	V _{DDQ} = min to max, I _{OH} = –1 mA	V _{DDQ} – 0.1			V
	V _{DDQ} = 2.3 V, I _{OH} = –12 mA	1.7			
V _{OL} Low-level output voltage	V _{DDQ} = min to max, I _{OL} = 1 mA			0.1	V
	V _{DDQ} = 2.3 V, I _{OL} = 12 mA			0.6	
V _{OD} Output voltage swing ⁽²⁾		1.1		V _{DDQ} – 0.4	V
V _{OX} Output differential cross-voltage ⁽³⁾	Differential outputs are terminated with 120 Ω, C _L = 14 pF (see Figure 3)	V _{DDQ} /2 – 0.1	V _{DDQ} /2	V _{DDQ} /2 + 0.1	V
I _I Input current	V _{DDQ} = 2.7 V, V _I = 0 V to 2.7 V			±10	μA
I _{OZ} High-impedance-state output current	V _{DDQ} = 2.7 V, V _O = V _{DDQ} or GND			±10	μA
I _{DDPD} Power-down current on V _{DDQ} + AV _{DD}	CLK and $\overline{\text{CLK}}$ = 0 MHz; $\overline{\text{PWRDWN}}$ = Low; Σ of I _{DD} and A _{I_{DD}}		20	100	μA
A _{I_{DD}} Supply current on AV _{DD}	f _O = 170 MHz		6	8	mA
	f _O = 200 MHz		8	10	
C _I Input capacitance	V _{DDQ} = 2.5 V, V _I = V _{DDQ} or GND	2	2.5	3.5	pF
I _{DD} Dynamic current on V _{DDQ}	Without load	f _O = 170 MHz	120	140	mA
		f _O = 200 MHz	125	150	
	Differential outputs terminated with 120 Ω, C _L = 0 pF	f _O = 170 MHz	220	270	
		f _O = 200 MHz	230	280	
	Differential outputs terminated with 120 Ω, C _L = 14 pF	f _O = 170 MHz	280	330	
		f _O = 200 MHz	300	350	

- (1) All typical values are at nominal V_{DDQ}.
- (2) The differential output signal voltage specifies the differential voltage |VTR – VCP|, where VTR is the true output level and VCP is the complementary output level.
- (3) The differential cross-point voltage tracks variations of V_{DDQ} and is the voltage at which the differential signals must cross.

ELECTRICAL CHARACTERISTICS (continued)

over recommended operating free-air temperature range (unless otherwise noted)

PARAMETER	TEST CONDITIONS	MIN	TYP (1)	MAX	UNIT
ΔC	Part-to-part input capacitance variation $V_{DDQ} = 2.5 \text{ V}$, $V_I = V_{DDQ}$ or GND			1	pF
$C_{I(\Delta)}$	Input capacitance difference between CLK and $\overline{\text{CLK}}$, FBIN, and $\overline{\text{FBIN}}$ $V_{DDQ} = 2.5 \text{ V}$, $V_I = V_{DDQ}$ or GND			0.25	pF

TIMING REQUIREMENTS

over recommended ranges of supply voltage and operating free-air temperature

PARAMETER	MIN	MAX	UNIT	
f_{CLK}	Operating clock frequency	60	220	MHz
	Application clock frequency	90	220	
	Input clock duty cycle	40%	60%	
	Stabilization time (PLL mode) (1)		10	μs
	Stabilization time (bypass mode) (2)		30	ns

- (1) The time required for the integrated PLL circuit to obtain phase lock of its feedback signal to its reference signal. For phase lock to be obtained, a fixed-frequency, fixed-phase reference signal must be present at CLK and V_{DD} must be applied. Until phase lock is obtained, the specifications for propagation delay, skew, and jitter parameters given in the switching characteristics table are not applicable. This parameter does not apply for input modulation under SSC application.
- (2) A recovery time is required when the device goes from power-down mode into bypass mode (AV_{DD} at GND).

SWITCHING CHARACTERISTICS

over operating free-air temperature range (unless otherwise noted)

PARAMETER	TEST CONDITIONS	MIN	TYP	MAX	UNIT
$t_{\text{PLH}}^{(1)}$	Low-to-high level propagation delay time Test mode/CLK to any output		3.5		ns
$t_{\text{PHL}}^{(1)}$	High-to-low level propagation delay time Test mode/CLK to any output		3.5		ns
$t_{\text{jit(per)}}^{(2)}$	Jitter (period), see Figure 7	100 MHz (PC1600)	-65	65	ps
		133/167/200 MHz (PC2100/2700/3200)	-30	30	
$t_{\text{jit(cc)}}^{(2)}$	Jitter (cycle-to-cycle), see Figure 4	100 MHz (PC1600)	-50	50	ps
		133/167/200 MHz (PC2100/2700/3200)	-35	35	
$t_{\text{jit(hper)}}^{(2)}$	Half-period jitter, see Figure 8	100 MHz (PC1600)	-100	100	ps
		133/167/200 MHz (PC2100/2700/3200)	-75	75	
$t_{\text{slr(o)}}$	Output clock slew rate, see Figure 9 Load: 120 Ω , 14 pF		1	2	V/ns
$t_{(\phi)}$	Static phase offset, see Figure 5 100/133/167/200 MHz		-50	50	ps
$t_{\text{sk(o)}}$	Output skew, see Figure 6 Load: 120 Ω , 14 pF; 100/133/167/200 MHz			40	ps

- (1) Refers to the transition of the noninverting output.
- (2) This parameter is assured by design but cannot be 100% production tested.

PARAMETER MEASUREMENT INFORMATION

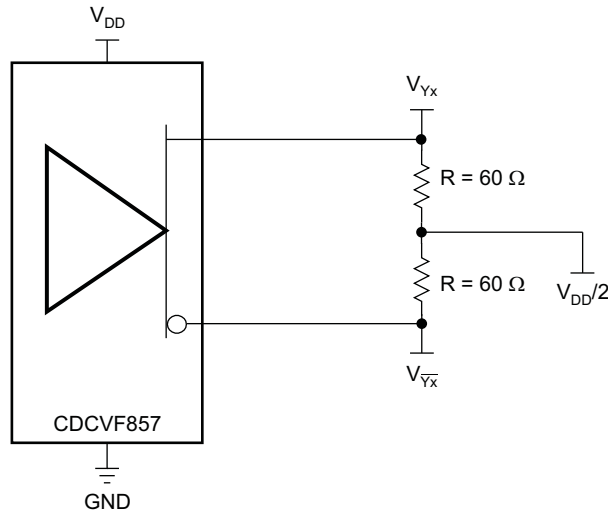

S0229-01

Figure 1. IBIS Model Output Load

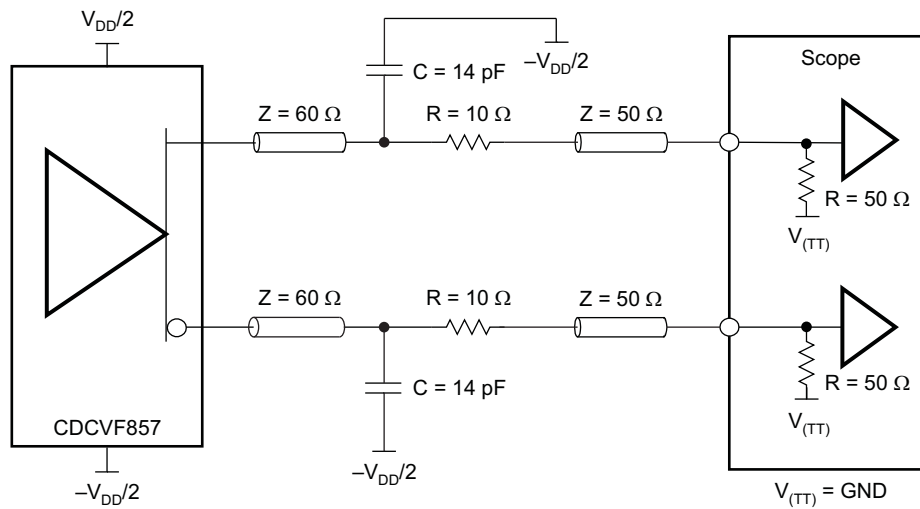

S0230-01

Figure 2. Output Load Test Circuit

PARAMETER MEASUREMENT INFORMATION (continued)

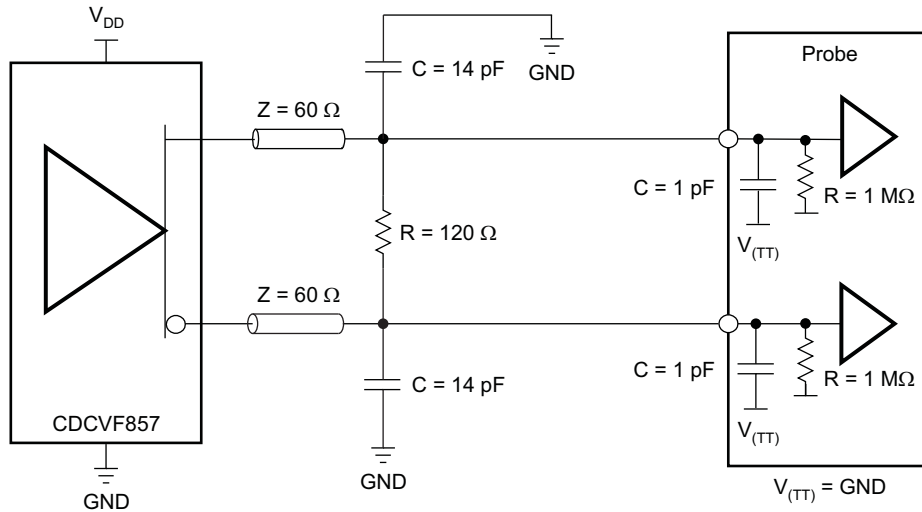

S0231-01

Figure 3. Output Load Test Circuit for Crossing Point

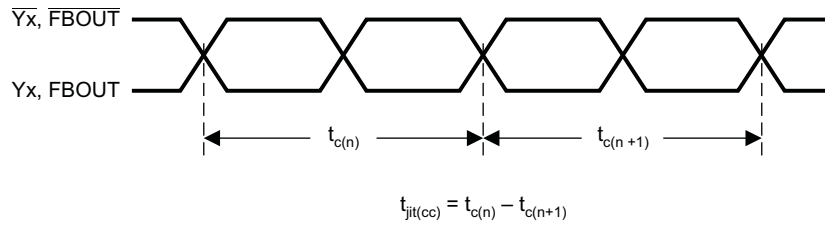

T0174-01

Figure 4. Cycle-to-Cycle Jitter

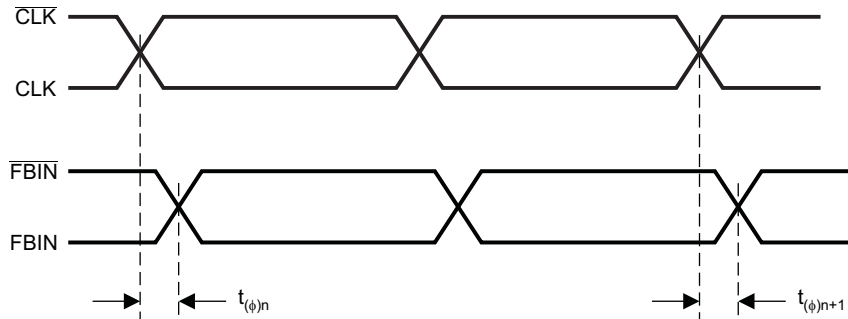

$$t_{(\phi)} = \frac{\sum_{n=1}^{n=N} t_{(\phi)n}}{N}$$

(N > 1000 Samples)

T0175-01

Figure 5. Phase Offset

PARAMETER MEASUREMENT INFORMATION (continued)

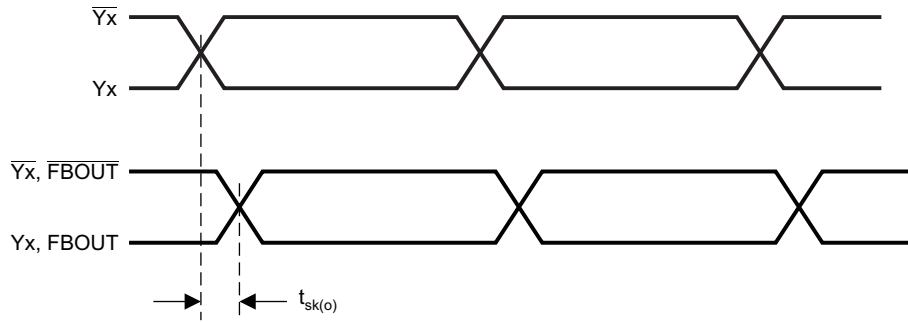

T0176-01

Figure 6. Output Skew

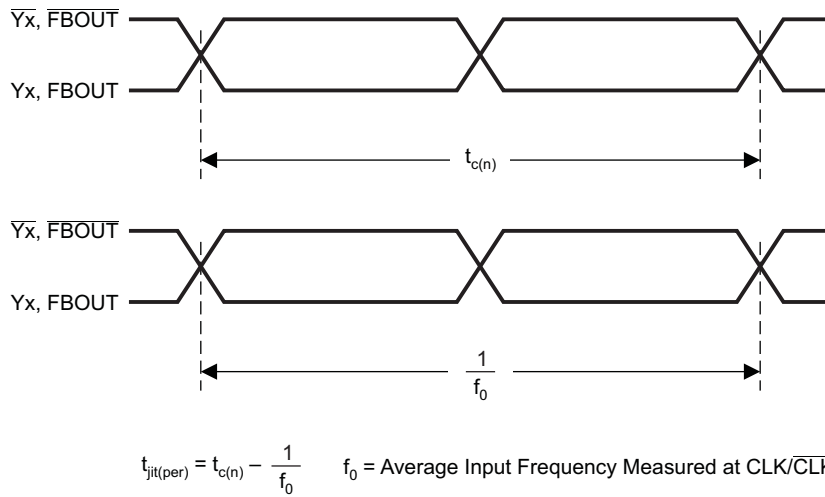

T0177-01

Figure 7. Period Jitter

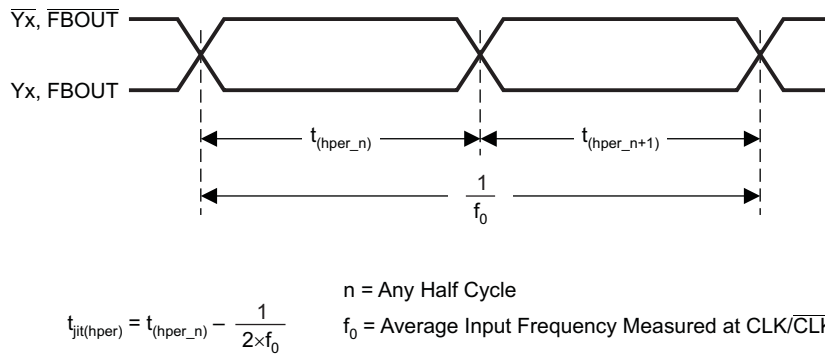

T0178-01

Figure 8. Half-Period Jitter

PARAMETER MEASUREMENT INFORMATION (continued)

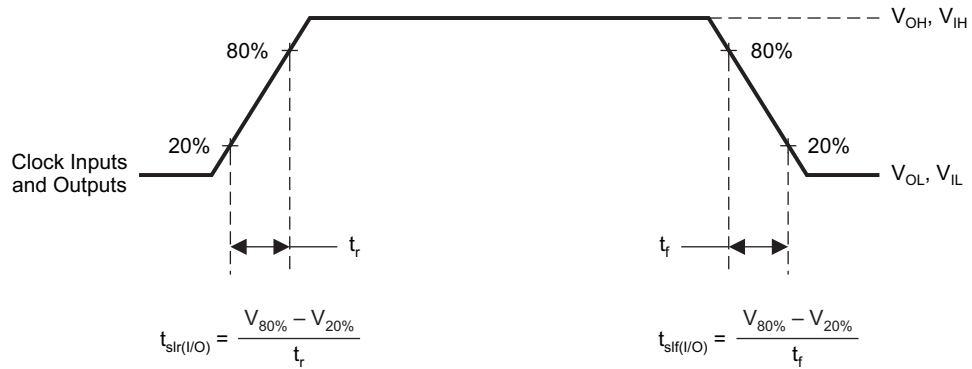

T0179-01

Figure 9. Input and Output Slew Rates

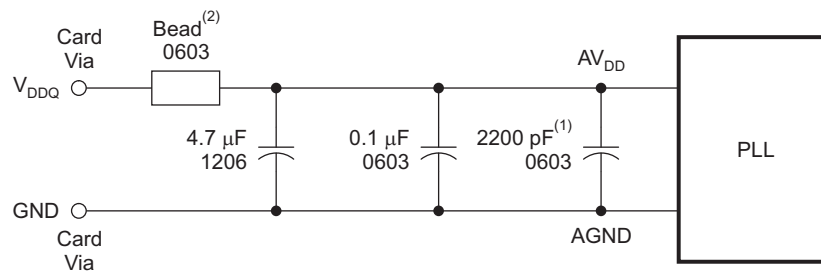

S0232-01

- (1) Place the 2200-pF capacitor close to the PLL.
- (2) Recommended bead: Fair-Rite P/N 2506036017Y0 or equivalent (0.8 Ω dc maximum, 600 Ω at 100 MHz).

NOTE: Use a wide trace for the PLL analog power and ground. Connect PLL and capacitors to AGND trace and connect trace to one GND via (farthest from the PLL).

Figure 10. Recommended AV_{DD} Filtering

PACKAGING INFORMATION

Orderable Device	Status (1)	Package Type	Package Drawing	Pins	Package Qty	Eco Plan (2)	Lead/Ball Finish (6)	MSL Peak Temp (3)	Op Temp (°C)	Device Marking (4/5)	Samples
CDCVF857DGG	ACTIVE	TSSOP	DGG	48	40	Green (RoHS & no Sb/Br)	CU NIPDAU	Level-2-260C-1 YEAR	-40 to 85	CDCVF857	Samples
CDCVF857DGGG4	ACTIVE	TSSOP	DGG	48	40	Green (RoHS & no Sb/Br)	CU NIPDAU	Level-2-260C-1 YEAR	-40 to 85	CDCVF857	Samples
CDCVF857DGGGR	ACTIVE	TSSOP	DGG	48	2000	Green (RoHS & no Sb/Br)	CU NIPDAU	Level-2-260C-1 YEAR	-40 to 85	CDCVF857	Samples
CDCVF857DGGRG4	ACTIVE	TSSOP	DGG	48	2000	Green (RoHS & no Sb/Br)	CU NIPDAU	Level-2-260C-1 YEAR	-40 to 85	CDCVF857	Samples
CDCVF857RHAT	ACTIVE	VQFN	RHA	40	250	Green (RoHS & no Sb/Br)	CU NIPDAU	Level-3-260C-168 HR	-40 to 85	CKVF857	Samples
CDCVF857RHATG4	ACTIVE	VQFN	RHA	40	250	Green (RoHS & no Sb/Br)	CU NIPDAU	Level-3-260C-168 HR	-40 to 85	CKVF857	Samples
CDCVF857ZQLR	LIFEBUY	BGA MICROSTAR JUNIOR	ZQL	56	1000	Green (RoHS & no Sb/Br)	SNAGCU	Level-1-260C-UNLIM	-40 to 85	CDCVF857	
HPA00126DGGR	ACTIVE	TSSOP	DGG	48	2000	Green (RoHS & no Sb/Br)	CU NIPDAU	Level-2-260C-1 YEAR	-40 to 85	CDCVF857	Samples

(1) The marketing status values are defined as follows:

ACTIVE: Product device recommended for new designs.

LIFEBUY: TI has announced that the device will be discontinued, and a lifetime-buy period is in effect.

NRND: Not recommended for new designs. Device is in production to support existing customers, but TI does not recommend using this part in a new design.

PREVIEW: Device has been announced but is not in production. Samples may or may not be available.

OBSELETE: TI has discontinued the production of the device.

(2) **RoHS:** TI defines "RoHS" to mean semiconductor products that are compliant with the current EU RoHS requirements for all 10 RoHS substances, including the requirement that RoHS substance do not exceed 0.1% by weight in homogeneous materials. Where designed to be soldered at high temperatures, "RoHS" products are suitable for use in specified lead-free processes. TI may reference these types of products as "Pb-Free".

RoHS Exempt: TI defines "RoHS Exempt" to mean products that contain lead but are compliant with EU RoHS pursuant to a specific EU RoHS exemption.

Green: TI defines "Green" to mean the content of Chlorine (Cl) and Bromine (Br) based flame retardants meet JS709B low halogen requirements of <=1000ppm threshold. Antimony trioxide based flame retardants must also meet the <=1000ppm threshold requirement.

(3) MSL, Peak Temp. - The Moisture Sensitivity Level rating according to the JEDEC industry standard classifications, and peak solder temperature.

(4) There may be additional marking, which relates to the logo, the lot trace code information, or the environmental category on the device.

⁽⁵⁾ Multiple Device Markings will be inside parentheses. Only one Device Marking contained in parentheses and separated by a "~" will appear on a device. If a line is indented then it is a continuation of the previous line and the two combined represent the entire Device Marking for that device.

⁽⁶⁾ Lead/Ball Finish - Orderable Devices may have multiple material finish options. Finish options are separated by a vertical ruled line. Lead/Ball Finish values may wrap to two lines if the finish value exceeds the maximum column width.

Important Information and Disclaimer:The information provided on this page represents TI's knowledge and belief as of the date that it is provided. TI bases its knowledge and belief on information provided by third parties, and makes no representation or warranty as to the accuracy of such information. Efforts are underway to better integrate information from third parties. TI has taken and continues to take reasonable steps to provide representative and accurate information but may not have conducted destructive testing or chemical analysis on incoming materials and chemicals. TI and TI suppliers consider certain information to be proprietary, and thus CAS numbers and other limited information may not be available for release.

In no event shall TI's liability arising out of such information exceed the total purchase price of the TI part(s) at issue in this document sold by TI to Customer on an annual basis.

TAPE AND REEL INFORMATION



QUADRANT ASSIGNMENTS FOR PIN 1 ORIENTATION IN TAPE



*All dimensions are nominal

Device	Package Type	Package Drawing	Pins	SPQ	Reel Diameter (mm)	Reel Width W1 (mm)	A0 (mm)	B0 (mm)	K0 (mm)	P1 (mm)	W (mm)	Pin1 Quadrant
CDCVF857DGGR	TSSOP	DGG	48	2000	330.0	24.4	8.6	13.0	1.8	12.0	24.0	Q1
CDCVF857RHAT	VQFN	RHA	40	250	180.0	16.4	6.3	6.3	1.1	12.0	16.0	Q2
CDCVF857ZQLR	BGA MICROSTAR JUNIOR	ZQL	56	1000	330.0	16.4	4.8	7.3	1.5	8.0	16.0	Q1

TAPE AND REEL BOX DIMENSIONS

*All dimensions are nominal

Device	Package Type	Package Drawing	Pins	SPQ	Length (mm)	Width (mm)	Height (mm)
CDCVF857DGGR	TSSOP	DGG	48	2000	367.0	367.0	45.0
CDCVF857RHAT	VQFN	RHA	40	250	210.0	185.0	35.0
CDCVF857ZQLR	BGA MICROSTAR JUNIOR	ZQL	56	1000	350.0	350.0	43.0

RHA (S-PVQFN-N40)

PLASTIC QUAD FLATPACK NO-LEAD

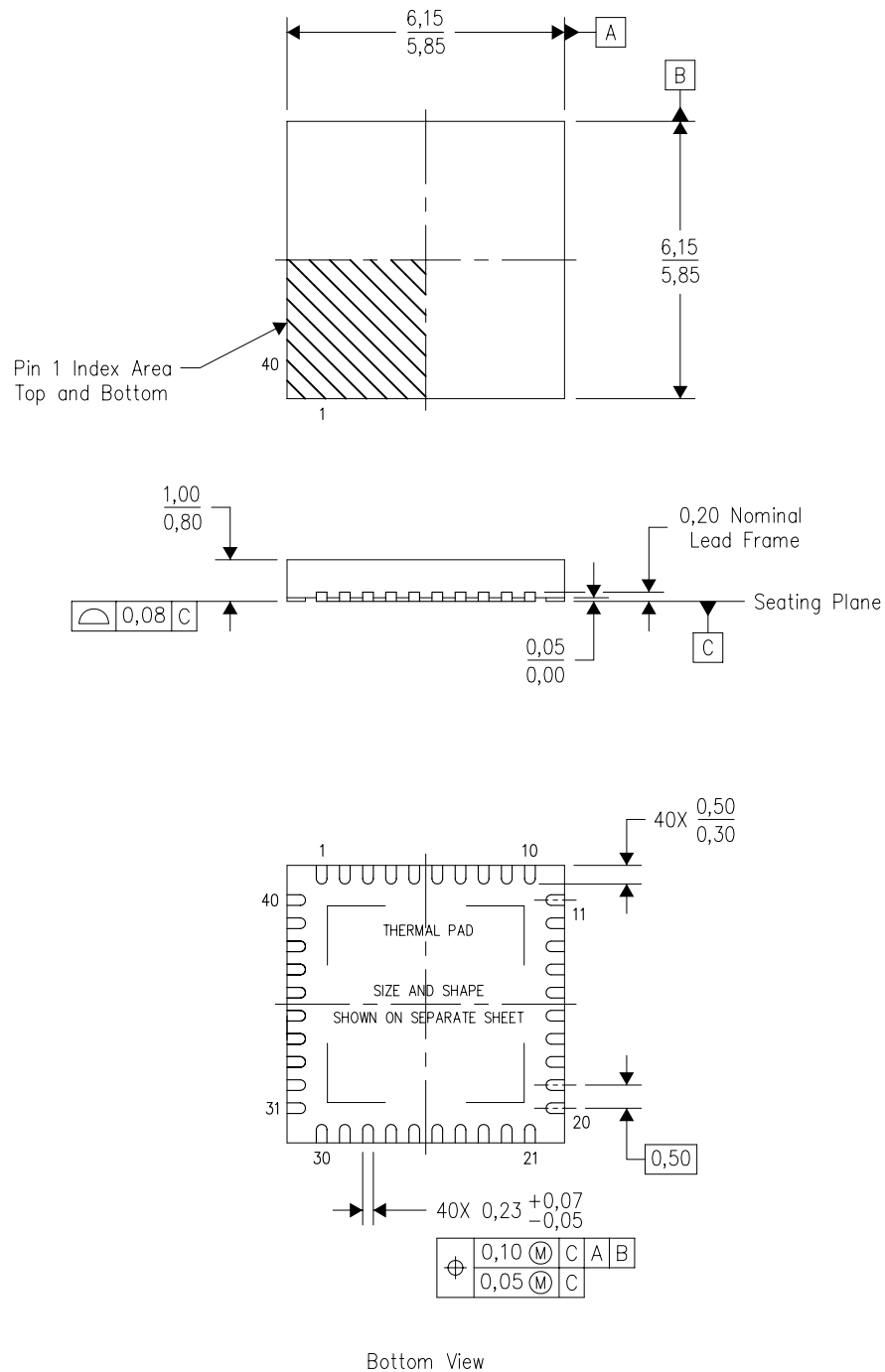

4204276/E 06/11

- NOTES:
- All linear dimensions are in millimeters. Dimensioning and tolerancing per ASME Y14.5M-1994.
 - This drawing is subject to change without notice.
 - QFN (Quad Flatpack No-Lead) Package configuration.
 - The package thermal pad must be soldered to the board for thermal and mechanical performance.
 - See the additional figure in the Product Data Sheet for details regarding the exposed thermal pad features and dimensions.
 - Package complies to JEDEC MO-220 variation VJJD-2.

THERMAL PAD MECHANICAL DATA

RHA (S-PVQFN-N40)

PLASTIC QUAD FLATPACK NO-LEAD

THERMAL INFORMATION

This package incorporates an exposed thermal pad that is designed to be attached directly to an external heatsink. The thermal pad must be soldered directly to the printed circuit board (PCB). After soldering, the PCB can be used as a heatsink. In addition, through the use of thermal vias, the thermal pad can be attached directly to the appropriate copper plane shown in the electrical schematic for the device, or alternatively, can be attached to a special heatsink structure designed into the PCB. This design optimizes the heat transfer from the integrated circuit (IC).

For information on the Quad Flatpack No-Lead (QFN) package and its advantages, refer to Application Report, QFN/SON PCB Attachment, Texas Instruments Literature No. SLUA271. This document is available at www.ti.com.

The exposed thermal pad dimensions for this package are shown in the following illustration.

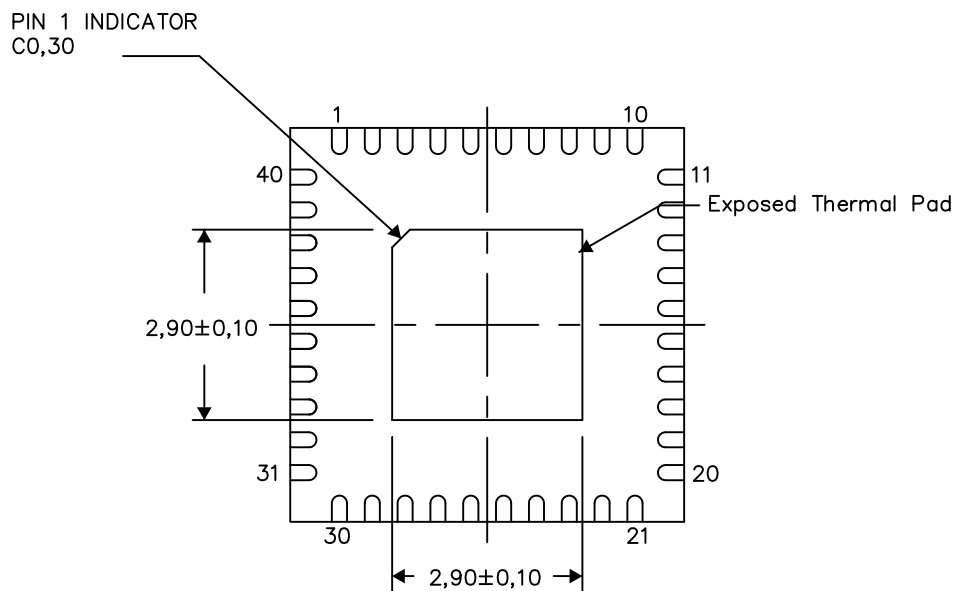

Bottom View

Exposed Thermal Pad Dimensions

4206355-3/X 08/14

NOTES: A. All linear dimensions are in millimeters

RHA (S-PVQFN-N40)

PLASTIC QUAD FLATPACK NO-LEAD

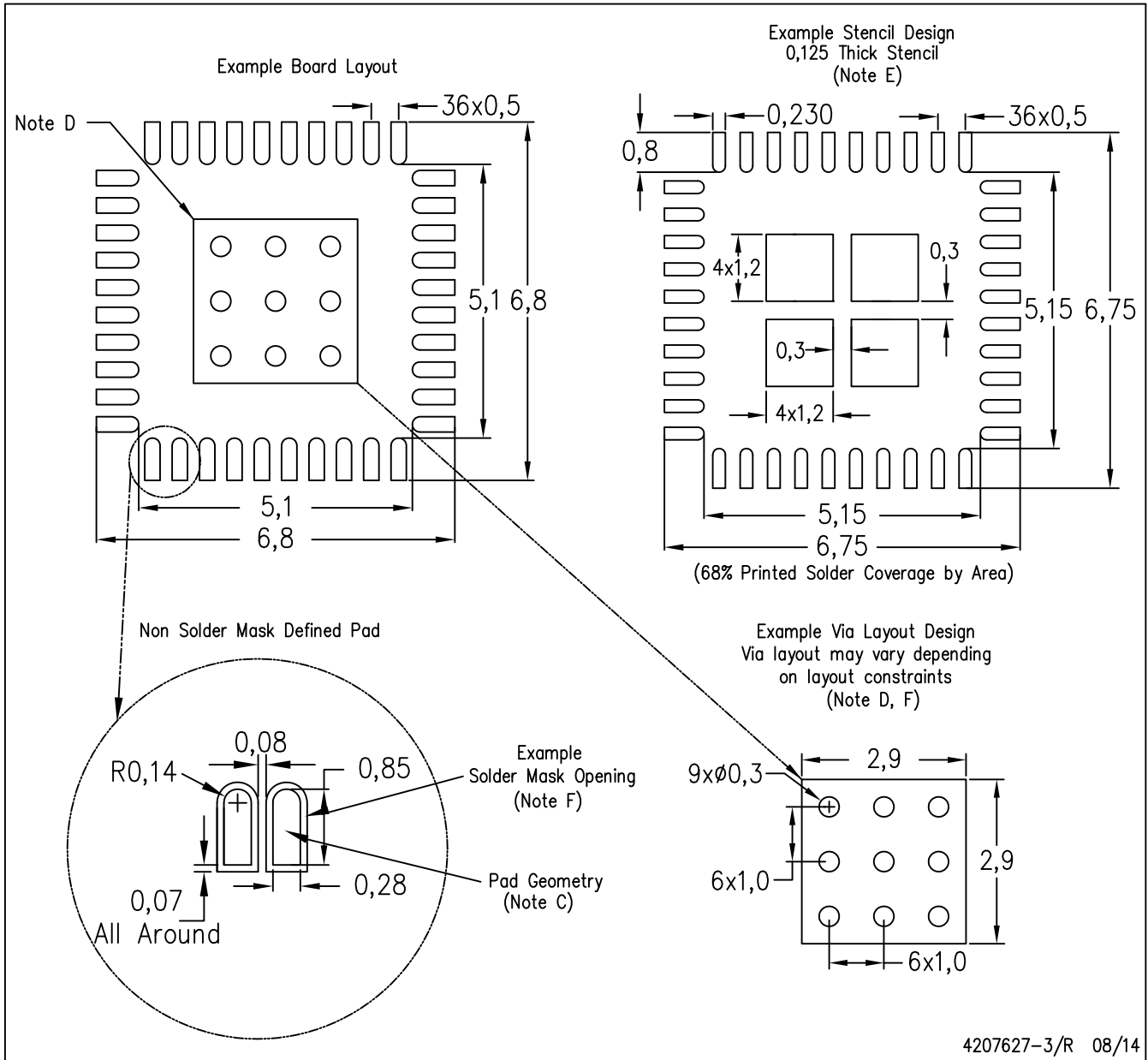

- NOTES:
- A. All linear dimensions are in millimeters.
 - B. This drawing is subject to change without notice.
 - C. Publication IPC-7351 is recommended for alternate designs.
 - D. This package is designed to be soldered to a thermal pad on the board. Refer to Application Note, Quad Flat-Pack Packages, Texas Instruments Literature No. SLUA271, and also the Product Data Sheets for specific thermal information, via requirements, and recommended board layout. These documents are available at www.ti.com <<http://www.ti.com>>.
 - E. Laser cutting apertures with trapezoidal walls and also rounding corners will offer better paste release. Customers should contact their board assembly site for stencil design recommendations. Refer to IPC 7525 for stencil design considerations.
 - F. Customers should contact their board fabrication site for recommended solder mask tolerances and via tenting recommendations for vias placed in the thermal pad.

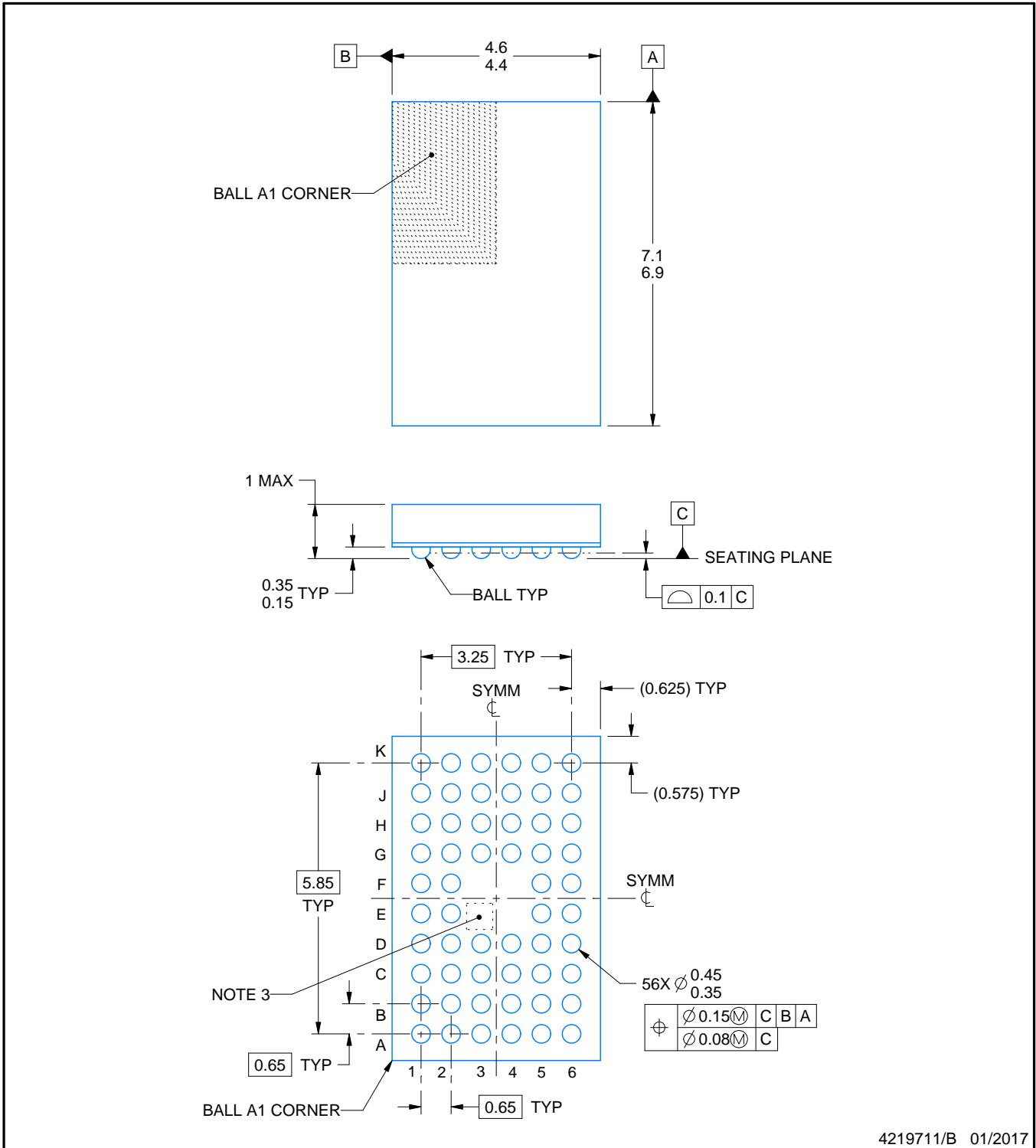
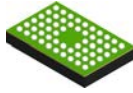

4219711/B 01/2017

NOTES:

1. All linear dimensions are in millimeters. Any dimensions in parenthesis are for reference only. Dimensioning and tolerancing per ASME Y14.5M.
2. This drawing is subject to change without notice.
3. No metal in this area, indicates orientation.

EXAMPLE BOARD LAYOUT

ZQL0056A

JRBGA - 1 mm max height

PLASTIC BALL GRID ARRAY

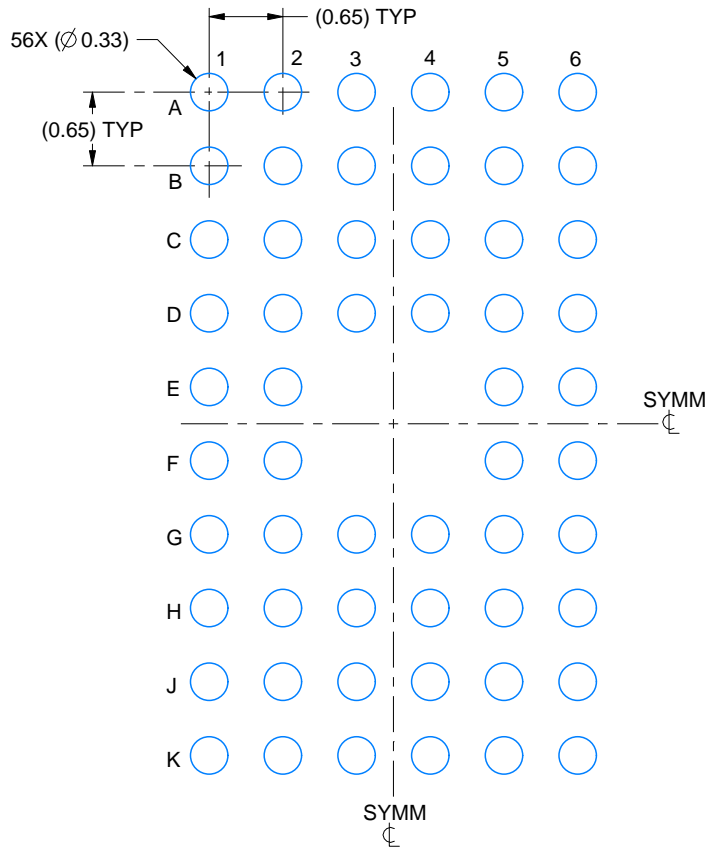

LAND PATTERN EXAMPLE
EXPOSED METAL SHOWN
SCALE:15X

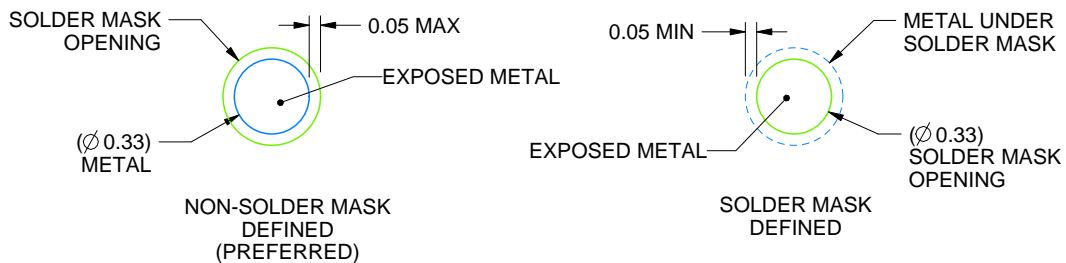

SOLDER MASK DETAILS
NOT TO SCALE

4219711/B 01/2017

NOTES: (continued)

- Final dimensions may vary due to manufacturing tolerance considerations and also routing constraints. For information, see Texas Instruments literature number SPRAA99 (www.ti.com/lit/spraa99).

EXAMPLE STENCIL DESIGN

ZQL0056A

JRBGA - 1 mm max height

PLASTIC BALL GRID ARRAY

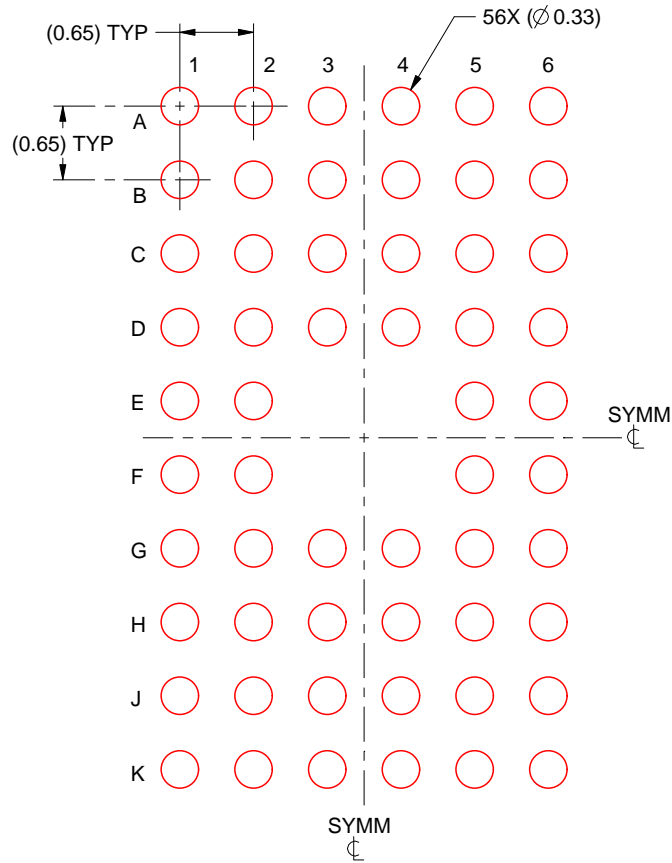

SOLDER PASTE EXAMPLE
BASED ON 0.125 mm THICK STENCIL
SCALE:15X

4219711/B 01/2017

NOTES: (continued)

5. Laser cutting apertures with trapezoidal walls and rounded corners may offer better paste release.

DGG (R-PDSO-G**)

PLASTIC SMALL-OUTLINE PACKAGE

48 PINS SHOWN

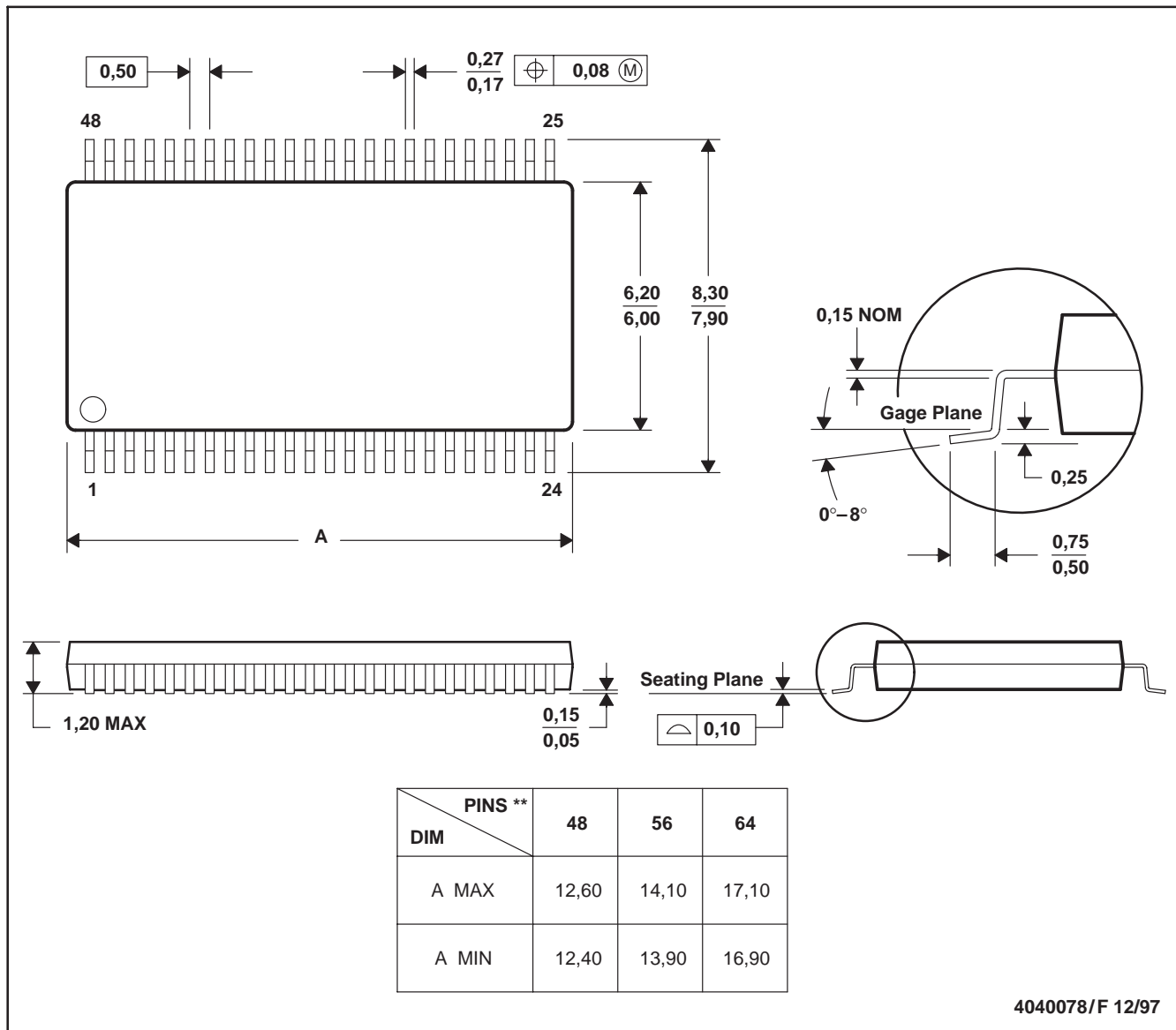

- NOTES: A. All linear dimensions are in millimeters.
 B. This drawing is subject to change without notice.
 C. Body dimensions do not include mold protrusion not to exceed 0,15.
 D. Falls within JEDEC MO-153

IMPORTANT NOTICE AND DISCLAIMER

TI PROVIDES TECHNICAL AND RELIABILITY DATA (INCLUDING DATASHEETS), DESIGN RESOURCES (INCLUDING REFERENCE DESIGNS), APPLICATION OR OTHER DESIGN ADVICE, WEB TOOLS, SAFETY INFORMATION, AND OTHER RESOURCES "AS IS" AND WITH ALL FAULTS, AND DISCLAIMS ALL WARRANTIES, EXPRESS AND IMPLIED, INCLUDING WITHOUT LIMITATION ANY IMPLIED WARRANTIES OF MERCHANTABILITY, FITNESS FOR A PARTICULAR PURPOSE OR NON-INFRINGEMENT OF THIRD PARTY INTELLECTUAL PROPERTY RIGHTS.

These resources are intended for skilled developers designing with TI products. You are solely responsible for (1) selecting the appropriate TI products for your application, (2) designing, validating and testing your application, and (3) ensuring your application meets applicable standards, and any other safety, security, or other requirements. These resources are subject to change without notice. TI grants you permission to use these resources only for development of an application that uses the TI products described in the resource. Other reproduction and display of these resources is prohibited. No license is granted to any other TI intellectual property right or to any third party intellectual property right. TI disclaims responsibility for, and you will fully indemnify TI and its representatives against, any claims, damages, costs, losses, and liabilities arising out of your use of these resources.

TI's products are provided subject to TI's Terms of Sale (www.ti.com/legal/termsofsale.html) or other applicable terms available either on ti.com or provided in conjunction with such TI products. TI's provision of these resources does not expand or otherwise alter TI's applicable warranties or warranty disclaimers for TI products.

Mailing Address: Texas Instruments, Post Office Box 655303, Dallas, Texas 75265
Copyright © 2019, Texas Instruments Incorporated

Looking for pricing, stock, or lifecycle information?

Click below to explore more details on WIN SOURCE:

 [View CDCVF857RHAR](#) on WIN SOURCE

 [Texas Instruments](#) Information

Optimize Your Supply Chain with WIN SOURCE Solutions

-  Global Sourcing Solution
-  Obsolete Management
-  Cost Control Management
-  Shortage Management
-  Alternative Solution
-  Excess Inventory Management