



**THE DATASHEET OF
PVA2A154A01R00**



Continued from the preceding page.

1

Construction

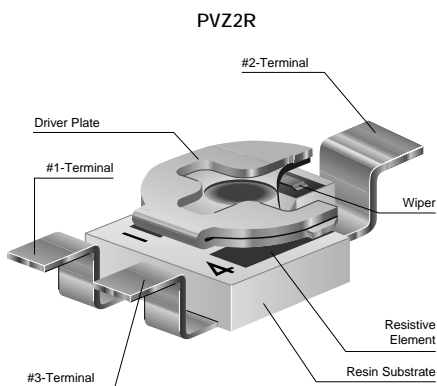

Standard Land Pattern

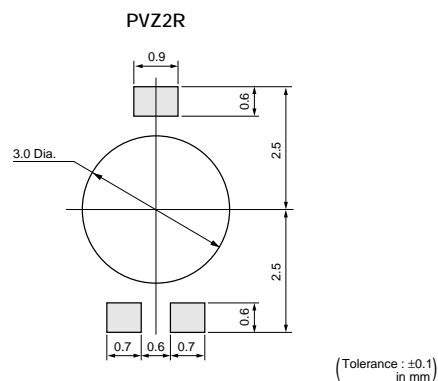

Characteristics

Humidity Exposure	Res. Change : +10, -2%
High Temperature Exposure	Res. Change : $R \leq 50\text{kohm} \dots +2, -10\%$ $50\text{kohm} < R \dots +2, -15\%$
Humidity Load Life	Res. Change : $\pm 10\%$
Load Life	Res. Change : $R \leq 50\text{kohm} \dots +2, -10\%$ $50\text{kohm} < R \dots +2, -15\%$
Temperature Cycle	Res. Change : $\pm 5\%$
Temperature Coefficient of Resistance	$\pm 500\text{ppm}/^\circ\text{C}$
Rotational Life	Res. Change : $\pm 10\%$ (10 cycles)

PVA2 Series

Features

- Ultra-small and thin external dimensions of 2.2(W)x2.75(L)x0.90 max.(T)mm.
- For the terminal attachment method of construction which uses neither solder nor adhesives, good solderability and terminal attachment intensity are realized.
- Because of multi-contact wiper structure, PVA2 have a stable characteristics (low noise).
- PVA2 series don't use a solder, flux and cleaning solvent, so they are environmentally friendly products.
- Heat resistance performance enables high temperature peak re-flow soldering.
- PVA2 series comply with RoHS directive.

Applications

- Thin-model optical pick-up module
- LCD module
- Optical communication module
- Small sensor module
- Digital camera
- Small telecommunication equipment, etc.

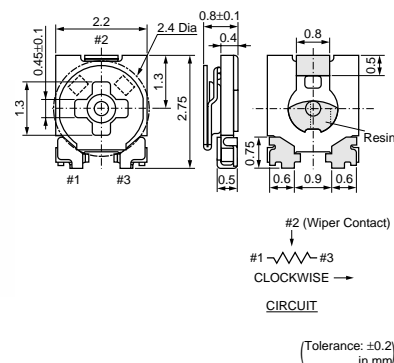

Part Number	Power Rating (W)	Soldering Method	Number of Turns (Effective Rotation Angle)	Total Resistance Value	TCR (ppm/°C)
PVA2A101A01	0.1(70°C)	Reflow/Soldering Iron	1(260°±10°)	100ohm ±25%	±250
PVA2A151A01	0.1(70°C)	Reflow/Soldering Iron	1(260°±10°)	150ohm ±25%	±250
PVA2A221A01	0.1(70°C)	Reflow/Soldering Iron	1(260°±10°)	220ohm ±25%	±250
PVA2A331A01	0.1(70°C)	Reflow/Soldering Iron	1(260°±10°)	330ohm ±25%	±250

Continued on the following page. ↗

Continued from the preceding page.

Part Number	Power Rating (W)	Soldering Method	Number of Turns (Effective Rotation Angle)	Total Resistance Value	TCR (ppm/°C)
PVA2A471A01	0.1(70°C)	Reflow/Soldering Iron	1(260°±10°)	470ohm ±25%	±250
PVA2A681A01	0.1(70°C)	Reflow/Soldering Iron	1(260°±10°)	680ohm ±25%	±250
PVA2A102A01	0.1(70°C)	Reflow/Soldering Iron	1(260°±10°)	1k ohm ±25%	±250
PVA2A152A01	0.1(70°C)	Reflow/Soldering Iron	1(260°±10°)	1.5k ohm ±25%	±250
PVA2A222A01	0.1(70°C)	Reflow/Soldering Iron	1(260°±10°)	2.2k ohm ±25%	±250
PVA2A332A01	0.1(70°C)	Reflow/Soldering Iron	1(260°±10°)	3.3k ohm ±25%	±250
PVA2A472A01	0.1(70°C)	Reflow/Soldering Iron	1(260°±10°)	4.7k ohm ±25%	±250
PVA2A682A01	0.1(70°C)	Reflow/Soldering Iron	1(260°±10°)	6.8k ohm ±25%	±250
PVA2A103A01	0.1(70°C)	Reflow/Soldering Iron	1(260°±10°)	10k ohm ±25%	±250
PVA2A153A01	0.1(70°C)	Reflow/Soldering Iron	1(260°±10°)	15k ohm ±25%	±250
PVA2A223A01	0.1(70°C)	Reflow/Soldering Iron	1(260°±10°)	22k ohm ±25%	±250
PVA2A333A01	0.1(70°C)	Reflow/Soldering Iron	1(260°±10°)	33k ohm ±25%	±250
PVA2A473A01	0.1(70°C)	Reflow/Soldering Iron	1(260°±10°)	47k ohm ±25%	±250
PVA2A683A01	0.1(70°C)	Reflow/Soldering Iron	1(260°±10°)	68k ohm ±25%	±250
PVA2A104A01	0.1(70°C)	Reflow/Soldering Iron	1(260°±10°)	100k ohm ±25%	±250
PVA2A154A01	0.1(70°C)	Reflow/Soldering Iron	1(260°±10°)	150k ohm ±25%	±250
PVA2A224A01	0.1(70°C)	Reflow/Soldering Iron	1(260°±10°)	220k ohm ±25%	±250
PVA2A334A01	0.1(70°C)	Reflow/Soldering Iron	1(260°±10°)	330k ohm ±25%	±250
PVA2A474A01	0.1(70°C)	Reflow/Soldering Iron	1(260°±10°)	470k ohm ±25%	±250
PVA2A684A01	0.1(70°C)	Reflow/Soldering Iron	1(260°±10°)	680k ohm ±25%	±250
PVA2A105A01	0.1(70°C)	Reflow/Soldering Iron	1(260°±10°)	1M ohm ±25%	±250
PVA2A155A01	0.1(70°C)	Reflow/Soldering Iron	1(260°±10°)	1.5M ohm ±25%	±250
PVA2A225A01	0.1(70°C)	Reflow/Soldering Iron	1(260°±10°)	2.2M ohm ±25%	±250

Operating Temperature Range: -55 to 125 °C

Construction

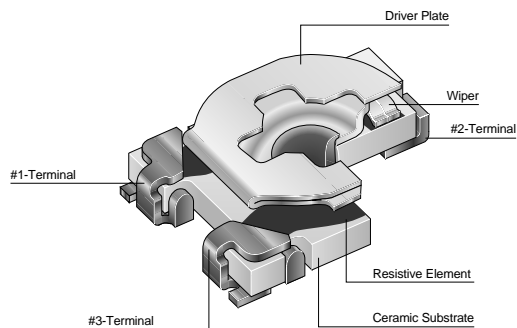

Standard Land Pattern

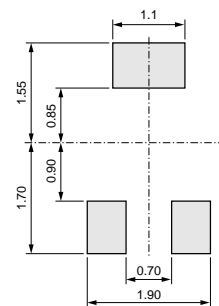

(Tolerance : ±0.1 in mm)

Characteristics

Humidity Exposure	Res. Change : ±3%
High Temperature Exposure	Res. Change : ±3%
Humidity Load Life	Res. Change : ±3%
Load Life	Res. Change : ±3%
Temperature Cycle	Res. Change : ±3%
Temperature Coefficient of Resistance	±250ppm/°C
Rotational Life	Res. Change : ±10% (10 cycles)

PVZ2/PVA2 Series Notice

■ Notice (Operating and Storage Conditions)

1. Store in temperatures of -10 to +40 deg. C and relative humidity of 30-85%RH.
2. Do not store in or near corrosive gases.
3. Use within six months after delivery.
4. Open the package just before using.
5. Do not store under direct sunlight.
6. If you use the trimmer potentiometer in an environment other than listed below, please consult with a Murata factory representative prior to using.

The trimmer potentiometer should not be used under the following environmental conditions:

- (1) Corrosive gaseous atmosphere
(Ex. Chlorine gas, Hydrogen sulfide gas, Ammonia gas, Sulfuric acid gas, Nitric oxide gas, etc.)
- (2) In liquid
(Ex. Oil, Medical liquid, Organic solvent, etc.)
- (3) Dusty/dirty atmosphere
- (4) Direct sunlight
- (5) Static voltage nor electric/magnetic fields
- (6) Direct sea breeze
- (7) Other variations of the above

■ Notice (Rating)

1. When using with partial load (rheostat), minimize the power depending on the resistance value.
2. The maximum input voltage to a trimmer potentiometer should not exceed $(P \cdot R)^{1/2}$ or the maximum operating voltage, whichever is smaller.
3. If the trimmer potentiometer is used in DC and high humidity conditions, please connect wiper (#2) for plus and resistive element (#1 or #3) for minus.
(PVZ Series only)

■ Notice (Soldering and Mounting)

1. Soldering

- (1) Reflow soldering method and soldering iron are available. Cannot be soldered using the flow soldering method (dipping). If you use the flow soldering method, the trimmer potentiometer may not function.
- (2) Use our standard land dimension. Excessive land area causes displacement due to the effect of the surface tension of the solder. Insufficient land area leads to insufficient soldering strength of the chip.
- (3) Soldering condition
Refer to the temperature profile.
If the soldering conditions are not suitable, e.g., excessive time and/or excessive temperature, the trimmer potentiometer may deviate from the specified characteristics.
- (4) Apply the appropriate amount of solder paste.
The thickness of solder paste should be printed from 100 micro m to 150 micro m and the dimension of land pattern used should be Murata's standard land pattern at reflow soldering.
Insufficient amounts of solder can lead to insufficient soldering strength on PCB.

Excessive amounts of solder may cause bridging between the terminals.

- (5) The soldering iron should not come in contact with the case of the trimmer potentiometer. If such contact does occur, the trimmer potentiometer may be damaged.

2. Mounting

- (1) Do not apply excessive force (preferably 4.9N (Ref.; 500gf) max.), when the trimmer potentiometer is mounted to the PCB.
- (2) Do not warp and/or bend PC board to prevent trimmer potentiometer from breakage.
- (3) In chip placers, the recommended size of the cylindrical pick-up nozzle should be outer dimension 1.5-1.8mm dia. and inner dimension 1.3mm dia.

3. Cleaning

- (1) In case there is flux on the resistive element, clean sufficiently with cleaning solvents and completely remove all residual flux.
- (2) Isopropyl-alcohol and Ethyl-alcohol are applicable solvents for cleaning. If you use any other types of solvents, please evaluate performance by your product.

PVZ2/PVA2 Series Notice

1

■ Soldering Profile

● Reflow Soldering Profile

1. Soldering profile for Lead-free solder (96.5Sn/3.0Ag/0.5Cu)

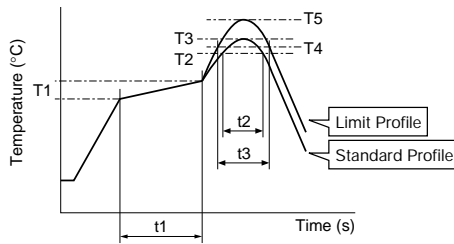

Series	Standard Profile						Limit Profile					
	Pre-heating		Heating		Peak Temperature (T3)	Cycle of Reflow	Pre-heating		Heating		Peak Temperature (T5)	Cycle of Reflow
	Temp. (T1)	Time (t1)	Temp. (T2)	Time (t2)			Temp. (T1)	Time (t1)	Temp. (T4)	Time (t3)		
°C	sec.	°C	sec.	°C	Time	°C	sec.	°C	sec.	°C	Time	
PVA2	150 to 180	60 to 120	220	30 to 60	245±3	2	150 to 180	60 to 120	220	30 to 60	260 +5/-0	2
PVZ2***A**	130 to 160	60 to 120	200	20 to 50	245±3	2	130 to 160	60 to 120	200	20 to 50	250	2
PVZ2***C**	150 to 180	60 to 120	220	30 to 60	245±3	2	150 to 180	60 to 120	220	30 to 60	260	2

2. Soldering profile for Eutectic solder (63Sn/37Pb)

(Limit profile: refer to 1)

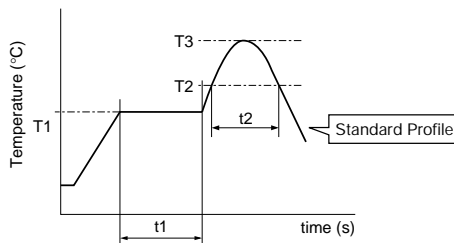

Series	Standard Profile					
	Pre-heating		Heating		Peak Temperature (T3)	Cycle of Reflow
	Temp. (T1)	Time (t1)	Temp. (T2)	Time (t2)		
°C	sec.	°C	sec.	°C	Time	
PVA2 PVZ2***A** PVZ2***C**	150	60 to 120	183	30	230	1

● Soldering Iron

Series	Standard Condition			
	Temperature of Soldering Iron Tip	Soldering Time	Soldering Iron Power Output	Cycle of Soldering Iron
	°C	sec.	W	Time
PVA2 PVZ2***A** PVZ2***C**	350±10	3 max.	30 max.	1

■ Notice (Handling)

- Use suitable screwdrivers that fit comfortably in driver slot. We recommend the screwdriver below.
* Recommended screwdriver for manual adjustment
Murata P/N: KMDR190
- Don't apply more than 4.9N (Ref.; 500gf) of twist and stress after mounting onto PCB to prevent contact intermittence. If excessive force is applied, the trimmer potentiometer may not function.
- Please use within the effective rotational angle. The trimmer potentiometer does not have a mechanical stop for over rotation. In cases out of effective rotational angle, the trimmer potentiometer may not function.
- When using a lock paint to fix slot position or cover the rotor, please evaluate performance by your product. Lock paint may cause corrosion or electrical contact problems.

■ Notice (Other)

- Please make sure that your product has been evaluated and confirmed against your specifications when our product is mounted to your product.
- Murata cannot guarantee trimmer potentiometer integrity when used under conditions other than those specified in this document.

Looking for pricing, stock, or lifecycle information?

Click below to explore more details on WIN SOURCE:

 [View PVA2A154A01R00 on WIN SOURCE](#)

 [Bourns Inc. Information](#)

Optimize Your Supply Chain with WIN SOURCE Solutions

-  Global Sourcing Solution
-  Obsolete Management
-  Cost Control Management
-  Shortage Management
-  Alternative Solution
-  Excess Inventory Management