



**THE DATASHEET OF
CDH53-101JC**



SPECIFICATION		
	SUMIDA TYPE CDH53	PART NO. REF. TO THE ATTACHED SHEET.

1. DIMENSION (UNIT mm)

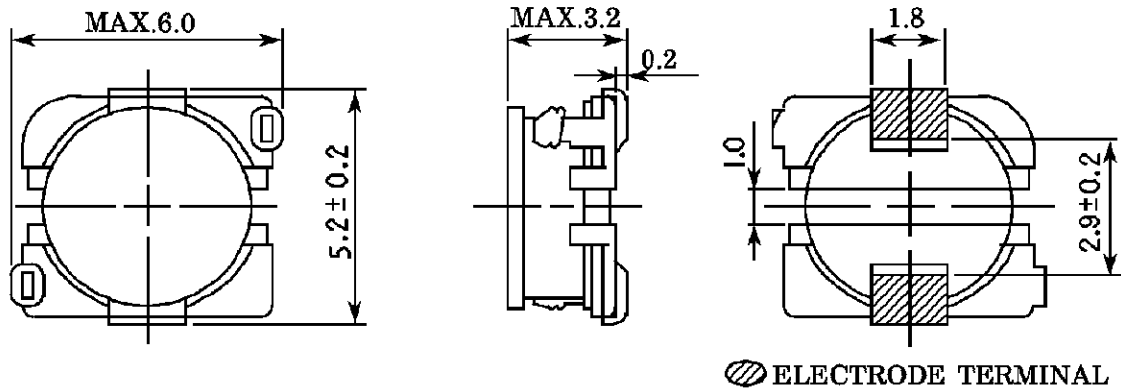

* DIMENSION WITHOUT TOLERANCE ARE APPROX.

2. CONNECTION

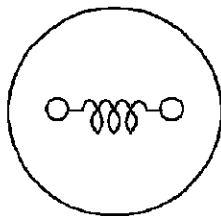

3. STAMP (Ex.)

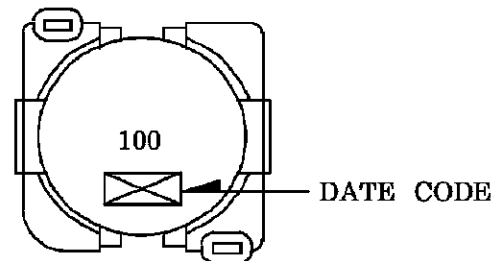

DIRECTLY STAMP
UNFIXED THE POSITION

4. NOTE

* ENCLOSING CONDITION OF COILS.

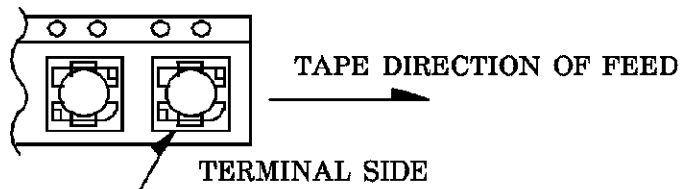

△ * IN THE CASE OF BOX:BOX PACKING AFTER CARRIER TAPE PACKING. (NO REEL)
IN THE CASE OF REEL:CARRIER TAPE PACKING SPECIFICATION IN DETAIL. (S-074-503)

*RECOMMENDED REFLOW CONDITION TO BE ACCORDING TO S-074-5003.

24 th AUG . , 1994			SUMIDA CODE	4736
CHK.	CHK.	DRG.	DRG. NO. 2/6	
O.SATO	KOMA ITA	MONMA M		
			S-074-506	

GENERAL CHARACTERISTICS

TYPE	CDH53
------	-------

1. OPERATING TEMPERATURE : - 30 ~ + 100 °C (COIL CONTAIN HEAT)
2. EXTERNAL APPEARANCE : ON VISUAL INSPECTION, THE COIL HAS NO EXTERNAL DEFECTS.
3. TERMINAL STRENGTH : AFTER SOLDERING, BETWEEN COPPER PLATE AND TERMINAL OF COIL, PUSH IN TWO DIRECTIONS OF X, Y WITHSTANDING 5.0N FOR 10±2 SECONDS. TERMINAL SHOULD NOT PEEL OFF. (REFER TO FIGURE AT RIGHT)

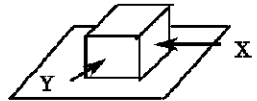
4. HEAT ENDURANCE TEST : REFER TO S-074-5002
5. DIELECTRIC STRENGTH : NO APPARENT AT 100V D.C. FOR 1 MINUTE BETWEEN COIL-CORE.
6. INSULATING RESISTANCE : OVER 100 MΩ AT 100V D.C. BETWEEN COIL-CORE.
7. INDUCTANCE TEMPERATURE COEFFICIENT : (0 ~ 2000) × 10⁻⁶/°C (-25 ~ + 80 °C)
8. HUMIDITY TEST : INDUCTANCE DEVIATION WITHIN ± 5 %

AFTER 96 HOURS IN 90 ~ 95 % RELATIVE HUMIDITY AT 40 ± 2 °C AND 1 HOUR DRYING UNDER NORMAL CONDITION.
9. VIBRATION TEST : INDUCTANCE DEVIATION WITHIN ± 3 % AFTER VIBRATION FOR 1 HOUR. IN EACH OF THREE ORIENTATIONS AT SWEEP VIBRATION (10~55~10 Hz) WITH 1.5 mm P-P AMPLITUDE.
10. SHOCK TEST : INDUCTANCE DEVIATION WITHIN ± 3 % AFTER DROP DOWN WITH 981m/s² SHOCK ATTITUDE UPON A RUBBER BLOCK METHOD SHOCK TESTING MACHINE, FOR 1 TIME, IN EACH OF THREE ORIENTATIONS.

24 th AUG . , 1994

CHK.	CHK.	DRG.
O.SATO	SUZUKI	MONMA M

DRG. NO.	3/6
S-074-506	

SPECIFICATION

TYPE	CDH53
------	-------

DIMENSION RECOMMENDED (mm)

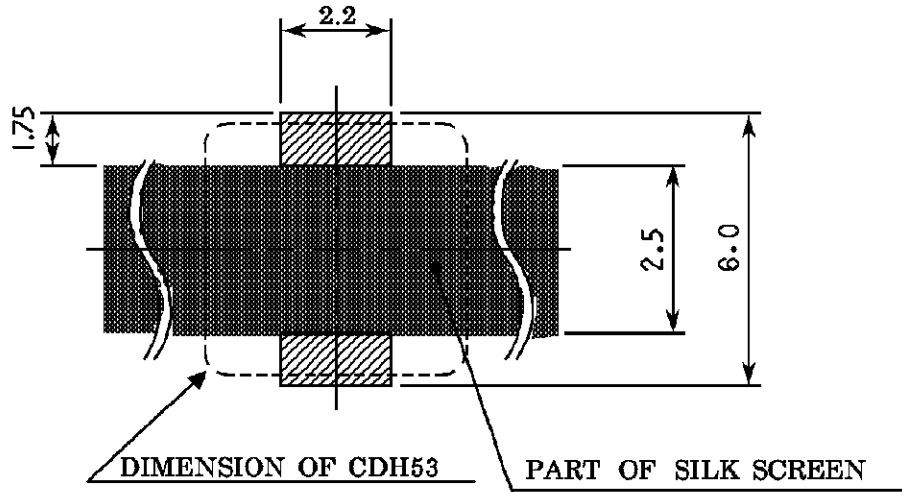

PLEASE COAT WITH SILK BETWEEN TERMINAL.



24 th AUG . , 1994

CHK.	CHK.	DRG.
O.SATO	SUZUKI	MONMA M

DRG. NO.	6/6
S-074-506	

Looking for pricing, stock, or lifecycle information?

Click below to explore more details on WIN SOURCE:

-  [View CDH53-101JC on WIN SOURCE](#)
-  [Sumida America Components Inc. Information](#)

Optimize Your Supply Chain with WIN SOURCE Solutions

-  Global Sourcing Solution
-  Obsolete Management
-  Cost Control Management
-  Shortage Management
-  Alternative Solution
-  Excess Inventory Management