



**THE DATASHEET OF  
R1LV5256ESA-5SI#B1**



# R1LV5256E Series

256Kb Advanced LPSRAM (32k word x 8bit)

R10DS0269EJ0200  
Rev.2.00  
2019.10.29

## Description

The R1LV5256E Series is a family of low voltage 256-Kbit static RAMs organized as 32,768-word by 8-bit, fabricated by Renesas's high-performance 0.15um CMOS and TFT technologies. The R1LV5256E Series has realized higher density, higher performance and low power consumption. The R1LV5256E Series is suitable for memory applications where a simple interfacing, battery operating and battery backup are the important design objectives. It has been packaged in 28-pin SOP and 28-pin TSOP.

## Features

- Single 2.7V~3.6V power supply
- Small stand-by current: 0.6μA (3.0V, typical)
- No clocks, No refresh
- All inputs and outputs are TTL compatible.
- Easy memory expansion by CS#
- Common Data I/O
- Three-state outputs: OR-tie Capability
- OE# prevents data contention on the I/O bus

## Ordering Information

Orderable part name	Access time	Temperature range	Package	Shipping container
R1LV5256ESP-5SI#B*	55 ns	-40 ~ +85°C	450-mil 28-pin plastic SOP	Tube (Magazine)
R1LV5256ESP-5SI#S*				Embossed tape
R1LV5256ESA-5SI#B*			8mm×13.4mm 28-pin plastic TSOP	Tray
R1LV5256ESA-5SI#S*				Embossed tape

Note 1. \* = Revision code for Assembly site change, etc. (\* = 0, 1, etc.)

## Pin Arrangement

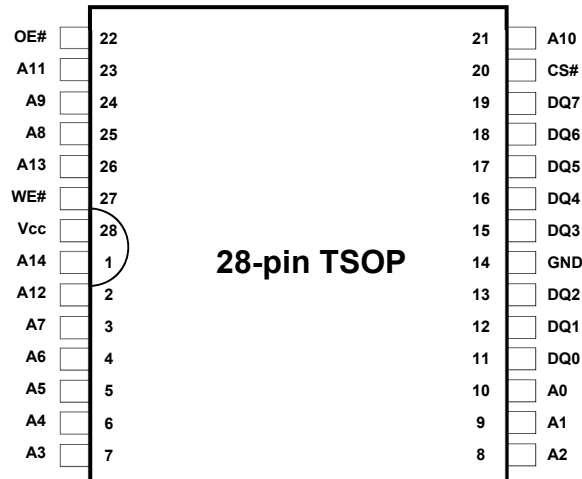
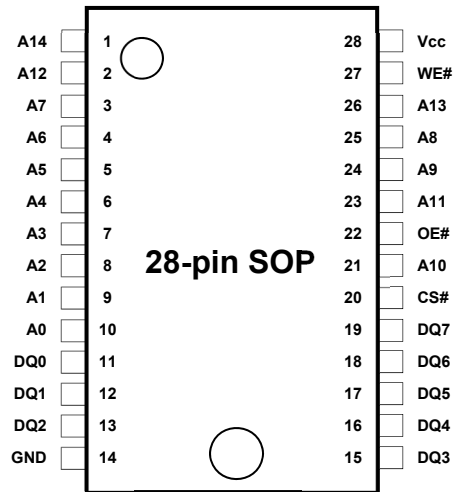

## Pin Description

Pin name	Function
Vcc	Power supply
Vss (GND)	Ground
A0 to A14	Address input
DQ0 to DQ7	Data input/output
CS#	Chip select
WE#	Write enable
OE#	Output enable

### Block Diagram

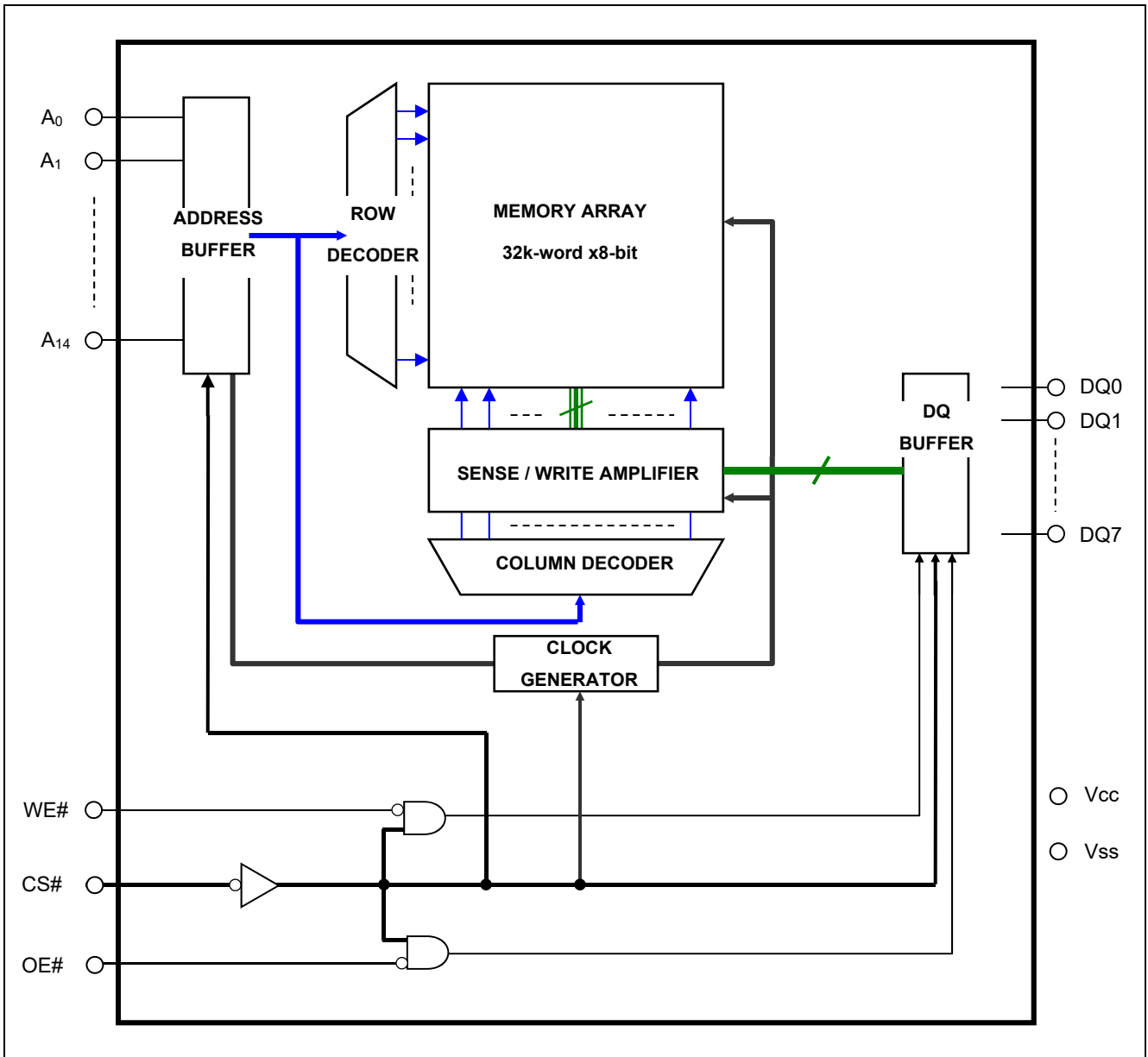

## Operation Table

CS#	WE#	OE#	DQ0~7	Operation
H	X	X	High-Z	Stand-by
L	L	X	Din	Write
L	H	L	Dout	Read
L	H	H	High-Z	Output disable

Note 1. H:  $V_{IH}$  L:  $V_{IL}$  X:  $V_{IH}$  or  $V_{IL}$

## Absolute Maximum

Parameter	Symbol	Value	unit
Power supply voltage relative to Vss	Vcc	-0.3 to +4.6	V
Terminal voltage on any pin relative to Vss	$V_T$	-0.3 <sup>1</sup> to Vcc+0.3 <sup>2</sup>	V
Power dissipation	$P_T$	0.7	W
Operation temperature	Topr	-40 to +85	°C
Storage temperature range	Tstg	-65 to 150	°C
Storage temperature range under bias	Tbias	-40 to +85	°C

Note 1. -3.0V for pulse  $\leq 30$ ns (full width at half maximum)  
 2. Maximum voltage is +4.6V.

## DC Operating Conditions

Parameter	Symbol	Min.	Typ.	Max.	Unit	Note
Supply voltage	V <sub>CC</sub>	2.7	3.0	3.6	V	
	V <sub>SS</sub>	0	0	0	V	
Input high voltage	V <sub>IH</sub>	2.0	-	V <sub>CC</sub> +0.3	V	
Input low voltage	V <sub>IL</sub>	-0.3	-	0.6	V	1
Ambient temperature range	T <sub>a</sub>	-40	-	+85	°C	

Note 1. -3.0V for pulse ≤ 30ns (full width at half maximum)

## DC Characteristics

Parameter	Symbol	Min.	Typ.	Max.	Unit	Test conditions	
Input leakage current	I <sub>LI</sub>	-	-	1	μA	V <sub>in</sub> = V <sub>SS</sub> to V <sub>CC</sub>	
Output leakage current	I <sub>LO</sub>	-	-	1	μA	CS# = V <sub>IH</sub> or OE# = V <sub>IH</sub> , V <sub>I/O</sub> = V <sub>SS</sub> to V <sub>CC</sub>	
Average operating current	I <sub>CC1</sub>	-	14	25	mA	Min. cycle, duty = 100%, I <sub>I/O</sub> = 0mA, CS# = V <sub>IL</sub> , Others = V <sub>IH</sub> /V <sub>IL</sub>	
	I <sub>CC2</sub>	-	2	5	mA	Cycle = 1μs, duty = 100%, I <sub>I/O</sub> = 0mA, CS# ≤ 0.2V, V <sub>IH</sub> ≥ V <sub>CC</sub> -0.2V, V <sub>IL</sub> ≤ 0.2V	
Standby current	I <sub>SB</sub>	-	-	0.33	mA	CS# = V <sub>IH</sub> , Others = V <sub>SS</sub> to V <sub>CC</sub>	
Standby current	I <sub>SB1</sub>	-	0.6 <sup>1</sup>	2	μA	~+25°C	V <sub>in</sub> = V <sub>SS</sub> to V <sub>CC</sub> , CS# ≥ V <sub>CC</sub> -0.2V
		-	-	3	μA	~+40°C	
		-	-	8	μA	~+70°C	
		-	-	10	μA	~+85°C	
Output high voltage	V <sub>OH</sub>	2.4	-	-	V	I <sub>OH</sub> = -0.5mA	
	V <sub>OH2</sub>	V <sub>CC</sub> - 0.5	-	-	V	I <sub>OH</sub> = -0.05mA	
Output low voltage	V <sub>OL</sub>	-	-	0.4	V	I <sub>OL</sub> = 1mA	

Note 1. Typical parameter indicates the value for the center of distribution at 3.0V (T<sub>a</sub> = 25°C), and not 100% tested.

## Capacitance

(V<sub>CC</sub> = 2.7V ~ 3.6V, f = 1MHz, T<sub>a</sub> = -40 ~ +85°C)

Parameter	Symbol	Min.	Typ.	Max.	Unit	Test conditions	Note
Input capacitance	C <sub>in</sub>	-	-	6	pF	V <sub>in</sub> = 0V	1
Input / output capacitance	C <sub>I/O</sub>	-	-	8	pF	V <sub>I/O</sub> = 0V	1

Note 1. This parameter is sampled and not 100% tested.

## AC Characteristics

Test Conditions ( $V_{CC} = 2.7V \sim 3.6V$ ,  $T_a = -40 \sim +85^{\circ}C$ )

- Input pulse levels:  $V_{IL} = 0.4V$ ,  $V_{IH} = 2.4V$
- Input rise and fall time: 5ns
- Input and output timing reference level: 1.5V
- Output load: See figures (Including scope and jig)

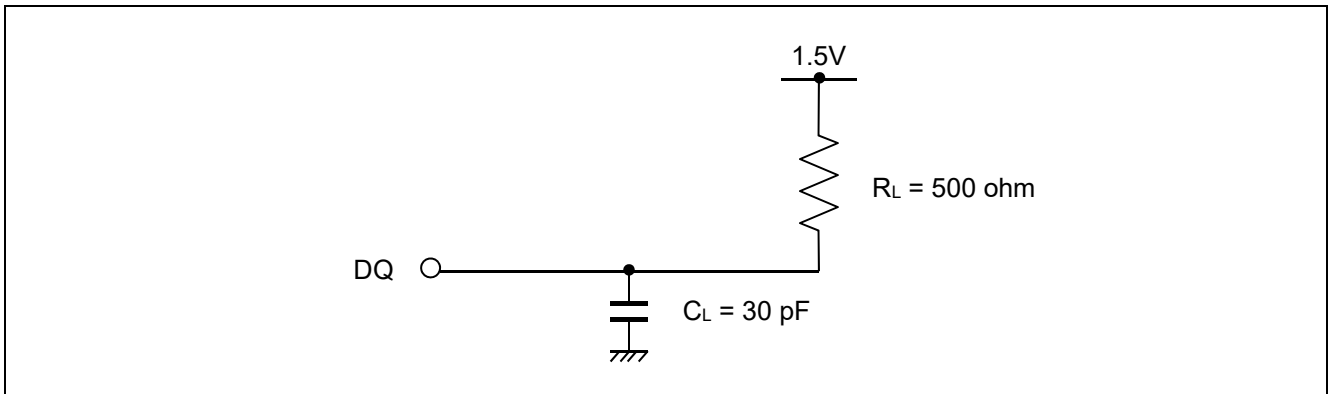

**Read Cycle**

Parameter	Symbol	Min.	Max.	Unit	Note
Read cycle time	t <sub>RC</sub>	55	-	ns	
Address access time	t <sub>AA</sub>	-	55	ns	
Chip select access time	t <sub>ACS</sub>	-	55	ns	
Output enable to output valid	t <sub>OE</sub>	-	30	ns	
Output hold from address change	t <sub>OH</sub>	10	-	ns	
Chip select to output in low-Z	t <sub>CLZ</sub>	5	-	ns	2,3
Output enable to output in low-Z	t <sub>OLZ</sub>	5	-	ns	2,3
Chip deselect to output in high-Z	t <sub>CHZ</sub>	0	20	ns	1,2,3
Output disable to output in high-Z	t <sub>OHZ</sub>	0	20	ns	1,2,3

**Write Cycle**

Parameter	Symbol	Min.	Max.	Unit	Note
Write cycle time	t <sub>WC</sub>	55	-	ns	
Address valid to end of write	t <sub>AW</sub>	50	-	ns	
Chip select to end of write	t <sub>CW</sub>	50	-	ns	5
Write pulse width	t <sub>WP</sub>	40	-	ns	4
Address setup time	t <sub>AS</sub>	0	-	ns	6
Write recovery time	t <sub>WR</sub>	0	-	ns	7
Data to write time overlap	t <sub>DW</sub>	25	-	ns	
Data hold from write time	t <sub>DH</sub>	0	-	ns	
Output enable from end of write	t <sub>OW</sub>	5	-	ns	2
Output disable to output in high-Z	t <sub>OHZ</sub>	0	20	ns	1,2
Write to output in high-Z	t <sub>WHZ</sub>	0	20	ns	1,2

- Note
1. t<sub>CHZ</sub>, t<sub>OHZ</sub> and t<sub>WHZ</sub> are defined as the time at which the outputs achieve the open circuit conditions and are not referred to output voltage levels.
  2. This parameter is sampled and not 100% tested.
  3. At any given temperature and voltage condition, t<sub>HZ</sub> max is less than t<sub>LZ</sub> min both for a given device and from device to device.
  4. A write occurs during the overlap of a low CS#, a low WE#.
    - A write begins at the latest transition among CS# going low and WE# going low.
    - A write ends at the earliest transition among CS# going high and WE# going high.
    - t<sub>WP</sub> is measured from the beginning of write to the end of write.
  5. t<sub>CW</sub> is measured from the later of CS# going low to end of write.
  6. t<sub>AS</sub> is measured the address valid to the beginning of write.
  7. t<sub>WR</sub> is measured from the earliest of CS# or WE# going high to the end of write cycle.
  8. Don't apply inverted phase signal externally when DQ pin is output mode.

## Timing Waveforms

### Read Cycle

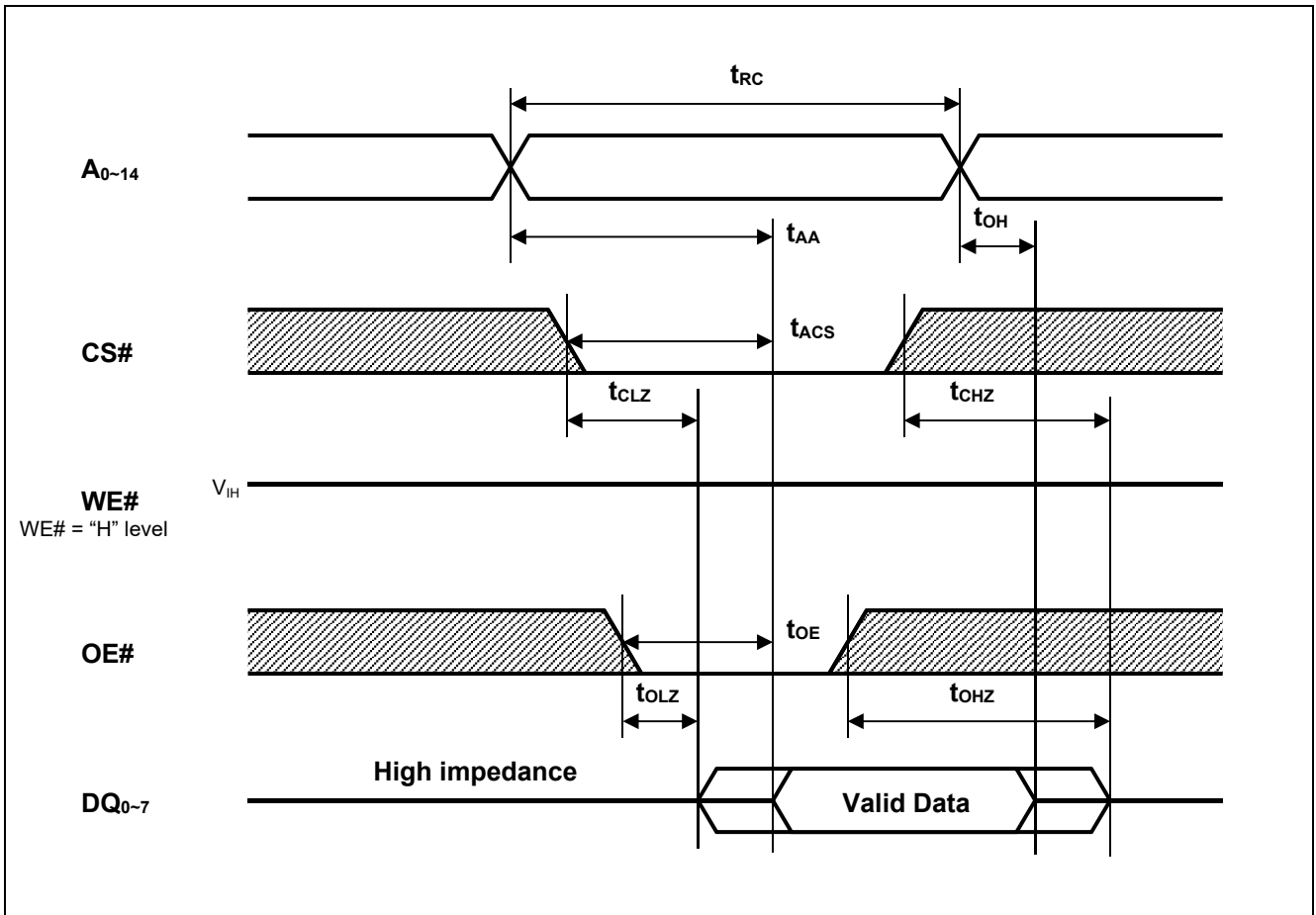

Write Cycle (1) (WE# CLOCK)

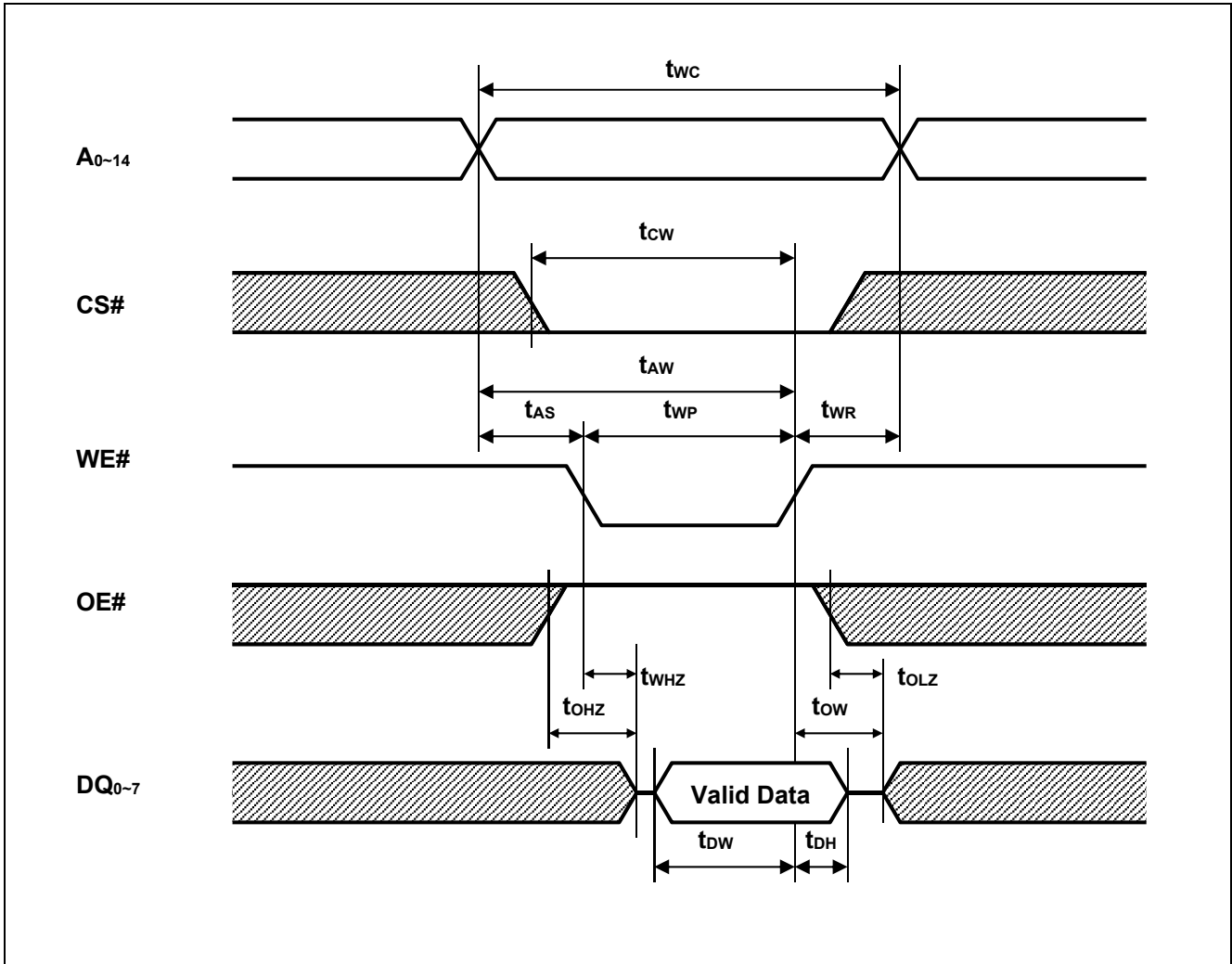

Write Cycle (2) (CS# CLOCK)

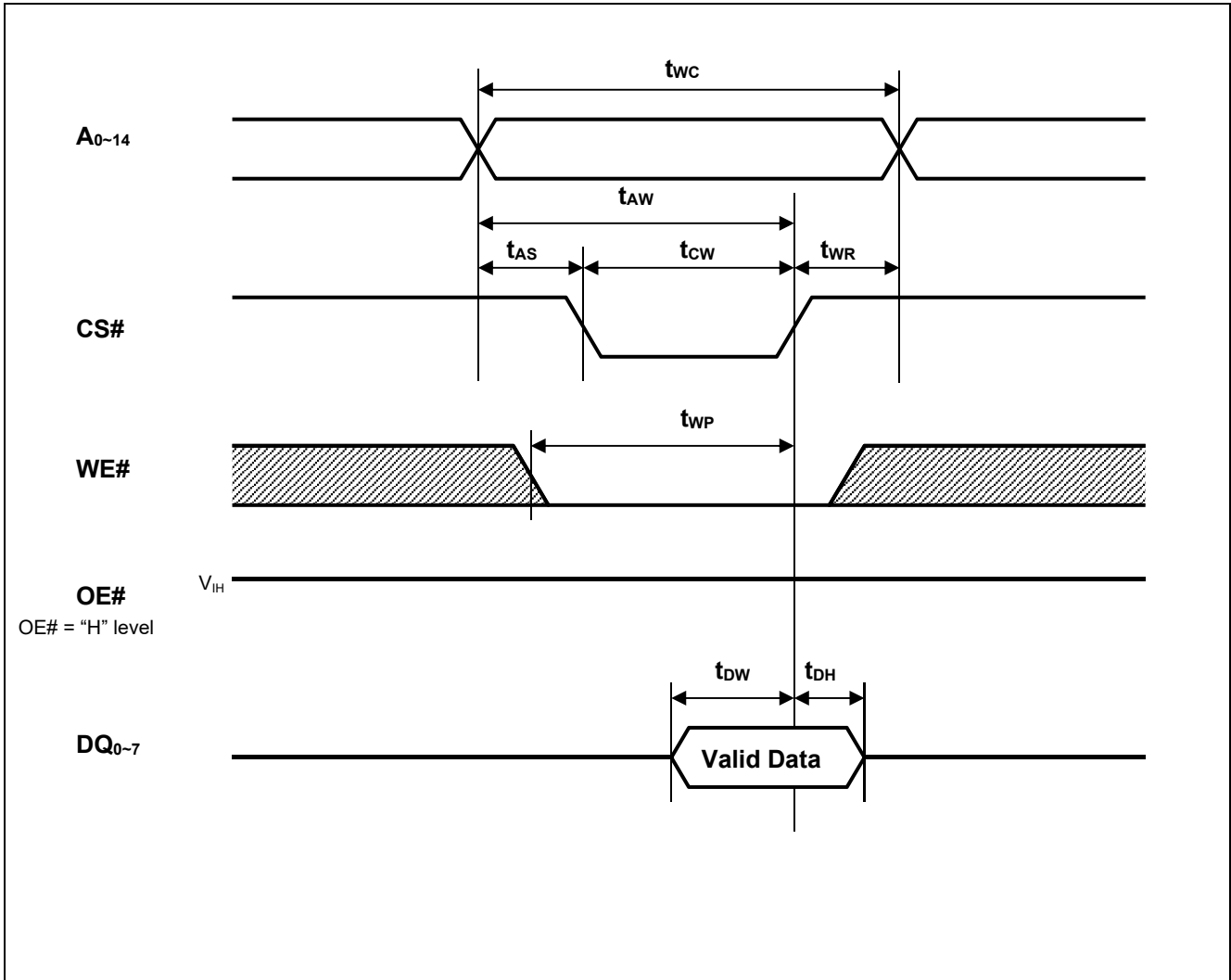

### Low Vcc Data Retention Characteristics

Parameter	Symbol	Min.	Typ.	Max.	Unit	Test conditions <sup>2</sup>	
V <sub>CC</sub> for data retention	V <sub>DR</sub>	2.0	-	3.6	V	V <sub>in</sub> ≥ 0V, CS# ≥ V <sub>CC</sub> -0.2V	
Data retention current	I <sub>CCDR</sub>	-	0.6 <sup>*1</sup>	2	μA	~+25°C	V <sub>CC</sub> =3.0V, V <sub>in</sub> ≥ 0V, CS# ≥ V <sub>CC</sub> -0.2V
		-	-	3	μA	~+40°C	
		-	-	8	μA	~+70°C	
		-	-	10	μA	~+85°C	
Chip deselect time to data retention	t <sub>CDR</sub>	0	-	-	ns	See retention waveform.	
Operation recovery time	t <sub>R</sub>	5	-	-	ms		

- Note
1. Typical parameter indicates the value for the center of distribution at 3.0V (T<sub>a</sub>= 25°C), and not 100% tested.
  2. CS# controls address buffer, WE# buffer, OE# buffer and Din buffer. If CS# controls data retention mode, V<sub>in</sub> levels (address, WE#, OE#, DQ) can be in the high impedance state.

### Low Vcc Data Retention Timing Waveforms

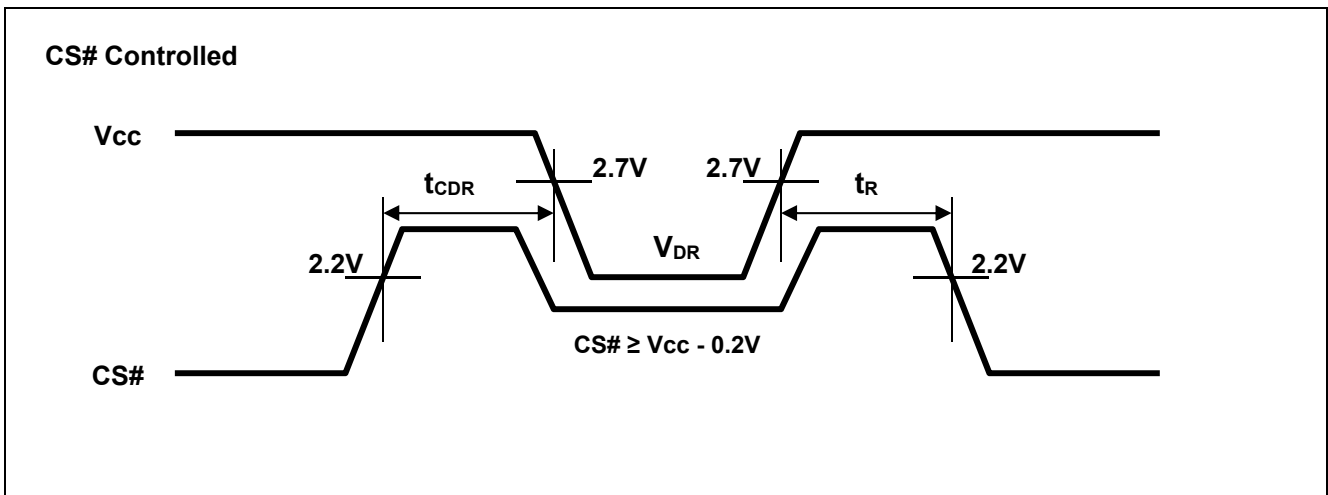

Revision History	R1LV5256E Series Data Sheet
------------------	-----------------------------

Rev.	Date	Description	
		Page	Summary
1.00	2017.1.27	-	First Edition issued
2.00	2019.10.29	p.1	Revised orderable part name information.

## IMPORTANT NOTICE AND DISCLAIMER

RENESAS ELECTRONICS CORPORATION AND ITS SUBSIDIARIES (“RENESAS”) PROVIDES TECHNICAL SPECIFICATIONS AND RELIABILITY DATA (INCLUDING DATASHEETS), DESIGN RESOURCES (INCLUDING REFERENCE DESIGNS), APPLICATION OR OTHER DESIGN ADVICE, WEB TOOLS, SAFETY INFORMATION, AND OTHER RESOURCES “AS IS” AND WITH ALL FAULTS, AND DISCLAIMS ALL WARRANTIES, EXPRESS OR IMPLIED, INCLUDING, WITHOUT LIMITATION, ANY IMPLIED WARRANTIES OF MERCHANTABILITY, FITNESS FOR A PARTICULAR PURPOSE, OR NON-INFRINGEMENT OF THIRD PARTY INTELLECTUAL PROPERTY RIGHTS.

These resources are intended for developers skilled in the art designing with Renesas products. You are solely responsible for (1) selecting the appropriate products for your application, (2) designing, validating, and testing your application, and (3) ensuring your application meets applicable standards, and any other safety, security, or other requirements. These resources are subject to change without notice. Renesas grants you permission to use these resources only for development of an application that uses Renesas products. Other reproduction or use of these resources is strictly prohibited. No license is granted to any other Renesas intellectual property or to any third party intellectual property. Renesas disclaims responsibility for, and you will fully indemnify Renesas and its representatives against, any claims, damages, costs, losses, or liabilities arising out of your use of these resources. Renesas' products are provided only subject to Renesas' Terms and Conditions of Sale or other applicable terms agreed to in writing. No use of any Renesas resources expands or otherwise alters any applicable warranties or warranty disclaimers for these products.

(Rev.1.0 Mar 2020)

### Corporate Headquarters

TOYOSU FORESIA, 3-2-24 Toyosu,  
Koto-ku, Tokyo 135-0061, Japan  
[www.renesas.com](http://www.renesas.com)

### Contact Information

For further information on a product, technology, the most up-to-date version of a document, or your nearest sales office, please visit:  
[www.renesas.com/contact/](http://www.renesas.com/contact/)

### Trademarks

Renesas and the Renesas logo are trademarks of Renesas Electronics Corporation. All trademarks and registered trademarks are the property of their respective owners.

## Looking for pricing, stock, or lifecycle information?

Click below to explore more details on WIN SOURCE:

- [View R1LV5256ESA-5SI#B1 on WIN SOURCE](#)
- [Renesas Electronics America Information](#)

## Optimize Your Supply Chain with WIN SOURCE Solutions

- ✓ Global Sourcing Solution
- ✓ Obsolete Management
- ✓ Cost Control Management
- ✓ Shortage Management
- ✓ Alternative Solution
- ✓ Excess Inventory Management