



**THE DATASHEET OF  
RT9020-31GB**



## 500mA, Low Dropout, Low Noise Ultra-Fast With Soft Start CMOS LDO Regulator

### General Description

The RT9020 is a high-performance, 500mA LDO regulator, offering extremely high PSRR and ultra-low dropout, ideal for portable RF and wireless applications with demanding performance and space requirements.

The RT9020 quiescent current is as low as 25µA, further prolonging the battery life. The RT9020 also works with low-ESR ceramic capacitors, reducing the amount of board space necessary for power applications, critical in hand-held wireless devices.

The RT9020 consumes typical 0.7µA in shutdown mode and has fast turn-on time less than 70µs (without C<sub>SS</sub>). The other features include ultra-low dropout voltage, high output accuracy, current limiting protection, and high ripple rejection ratio. Tiny packages SOT-23-5 and SC-70-5 are available.

### Ordering Information

RT9020-□□□□	
	Package Type
	B : SOT-23-5
	U5 : SC-70-5
	Lead Plating System
	P : Pb Free
	G : Green (Halogen Free and Pb Free)
	Fixed Output Voltage
	12 : 1.2V
	15 : 1.5V
	16 : 1.6V
	⋮
	32 : 3.2V
	33 : 3.3V
	1B : 1.25V
	1H : 1.85V
	2H : 2.85V

Note :

Richtek products are :

- ▶ RoHS compliant and compatible with the current requirements of IPC/JEDEC J-STD-020.
- ▶ Suitable for use in SnPb or Pb-free soldering processes.

### Features

- Wide Operating Voltage Ranges : 2.2V to 5.5V
- Low Dropout : 250mV at 500mA
- 5mA Discharge Current of V<sub>OUT</sub> when IC Shutdown
- Ultra-Low-Noise for DSC Application
- Ultra-Fast Response in Line/Load Transient
- Current Limiting Protection
- Thermal Shutdown Protection
- High Power Supply Rejection Ratio
- Output Only 1µF Capacitor Required for Stability
- TTL-Logic-Controlled Shutdown Input
- RoHS Compliant and 100% Lead (Pb)-Free
- Moisture Sensitivity Level : Level 3

### Applications

- Digital Still Camera
- CDMA/GSM Cellular Handsets
- Portable Information Appliances
- Laptop, Palmtops, Notebook Computers
- Mini PCI & PCI-Express Cards
- PCMCIA & New Cards

### Marking Information

For marking information, contact our sales representative directly or through a Richtek distributor located in your area.

### Pin Configuration

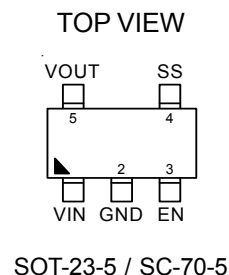

Typical Application Circuit

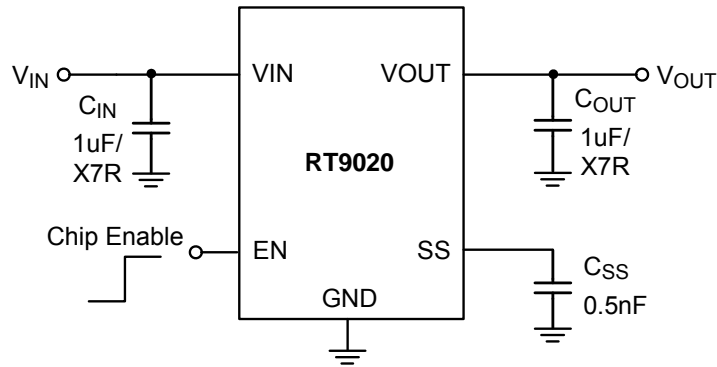

Functional Pin Description

Pin Number	Pin Name	Pin Function
1	VIN	Supply input.
2	GND	Common ground.
3	EN	Enable input logic, active high. When the EN goes to a logic low, the device will be shutdown.
4	SS	Soft start.
5	VOUT	Regulator output.

Functional Block Diagram

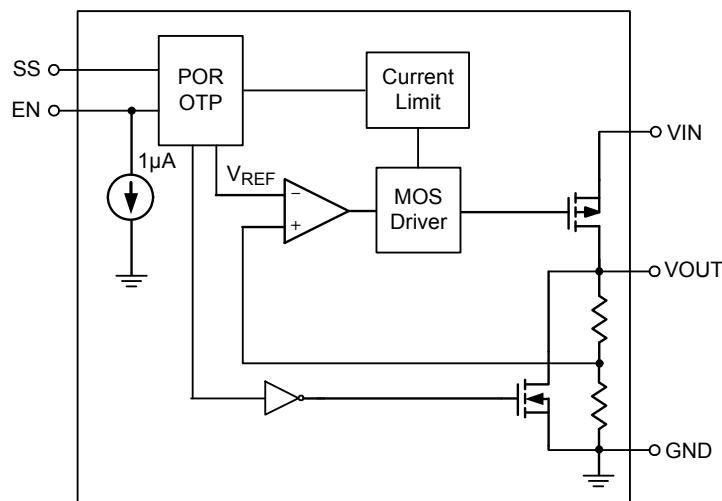

**Absolute Maximum Ratings** (Note 1)

- Supply Input Voltage ----- 6V
- EN Input Voltage ----- 6V
- Power Dissipation,  $P_D$  @  $T_A = 25^\circ\text{C}$ 
  - SOT-23-5 ----- 0.4W
  - SC-70-5 ----- 0.3W
- Package Thermal Resistance (Note 2)
  - SOT-23-5,  $\theta_{JA}$  -----  $250^\circ\text{C/W}$
  - SC-70-5,  $\theta_{JA}$  -----  $333^\circ\text{C/W}$
- Lead Temperature (Soldering, 10 sec.) -----  $260^\circ\text{C}$
- Junction Temperature -----  $150^\circ\text{C}$
- Storage Temperature Range -----  $-65^\circ\text{C}$  to  $150^\circ\text{C}$
- ESD Susceptibility (Note 3)
  - HBM (Human Body Model) ----- 2kV
  - MM (Machine Model) ----- 200V

**Recommended Operating Conditions** (Note 4)

- Supply Input Voltage ----- 2.2V to 5.5V
- Junction Temperature Range -----  $-40^\circ\text{C}$  to  $125^\circ\text{C}$
- Ambient Temperature Range -----  $-40^\circ\text{C}$  to  $85^\circ\text{C}$

**Electrical Characteristics**

( $V_{IN} = V_{OUT} + 0.5\text{V}$ ,  $V_{EN} = V_{IN}$ ,  $C_{IN} = C_{OUT} = 1\mu\text{F}$  (Ceramic),  $T_A = 25^\circ\text{C}$  unless otherwise specified)

Parameter	Symbol	Test Conditions	Min	Typ	Max	Unit
Input Voltage Range	$V_{IN}$		2.2	--	5.5	V
Output Noise Voltage	$V_{ON}$	$V_{OUT} = 1.5\text{V}$ , $C_{OUT} = 1\mu\text{F}$ , $I_{OUT} = 0\text{mA}$ , $C_{SS} = 1\text{nF}$	--	40	--	$\mu\text{VRMS}$
Output Voltage Accuracy (Fixed Output Voltage)	$\Delta V_{OUT}$	$I_{OUT} = 10\text{mA}$	-2	0	+2	%
Quiescent Current (Note 5)	$I_Q$	$V_{EN} = 5\text{V}$ , $I_{OUT} = 0\text{mA}$	--	25	50	$\mu\text{A}$
Standby Current	$I_{STBY}$	$V_{EN} = 0\text{V}$	--	0.7	1.5	$\mu\text{A}$
Current Limit	$I_{LIM}$	$R_{LOAD} = 0\Omega$ , $2.2\text{V} \leq V_{IN} < 2.6\text{V}$	0.4	0.7	1.05	A
		$R_{LOAD} = 0\Omega$ , $2.7\text{V} \leq V_{IN} \leq 5.5\text{V}$	0.5	0.8	1.05	
Dropout Voltage (Note 6)	$V_{DROP}$	$I_{OUT} = 400\text{mA}$ , $2.2\text{V} \leq V_{IN} < 2.7\text{V}$	--	160	320	mV
		$I_{OUT} = 500\text{mA}$ , $2.7\text{V} \leq V_{IN} \leq 5.5\text{V}$	--	250	400	
Load Regulation (Note 7) (Fixed Output Voltage)	$\Delta V_{LOAD}$	$1\text{mA} < I_{OUT} < 400\text{mA}$ $2.2\text{V} \leq V_{IN} < 2.7\text{V}$	--	--	0.6	%
		$1\text{mA} < I_{OUT} < 500\text{mA}$ $2.7\text{V} \leq V_{IN} \leq 5.5\text{V}$	--	--	1	
Soft Start Time		$V_{OUT} = 2.5\text{V}$ , $C_{SS} = 1\text{nF}$	--	0.7	1	ms

Parameter		Symbol	Test Conditions	Min	Typ	Max	Unit
EN Threshold	Logic-Low Voltage	$V_{IL}$		0	--	0.6	V
	Logic-High Voltage	$V_{IH}$		1.6	--	5.5	
Enable Pin Current		$I_{EN}$		0.1	1	5	$\mu A$
Power Supply Rejection Rate	$f = 10kHz$	PSRR	$I_{OUT} = 10mA$	--	-55	--	dB
Line Regulation		$\Delta V_{LINE}$	$V_{IN} = (V_{OUT}+0.5)$ to 5.5V, $I_{OUT} = 1mA$	--	0.01	0.2	%/V
Thermal Shutdown Temperature		$T_{SD}$		--	170	--	$^{\circ}C$
Thermal Shutdown Hysteresis		$\Delta T_{SD}$		--	30	--	

**Note 1.** Stresses beyond those listed “Absolute Maximum Ratings” may cause permanent damage to the device. These are stress ratings only, and functional operation of the device at these or any other conditions beyond those indicated in the operational sections of the specifications is not implied. Exposure to absolute maximum rating conditions may affect device reliability.

**Note 2.**  $\theta_{JA}$  is measured at  $T_A = 25^{\circ}C$  on a low effective thermal conductivity single-layer test board per JEDEC 51-3.

**Note 3.** Devices are ESD sensitive. Handling precaution recommended.

**Note 4.** The device is not guaranteed to function outside its operating conditions.

**Note 5.** Quiescent, or ground current, is the difference between input and output currents. It is defined by  $I_Q = I_{IN} - I_{OUT}$  under no load condition ( $I_{OUT} = 0mA$ ). The total current drawn from the supply is the sum of the load current plus the ground pin current.

**Note 6.** The dropout voltage is defined as  $V_{IN} - V_{OUT}$ , which is measured when  $V_{OUT}$  is  $V_{OUT(NORMAL)} - 100mV$ .

**Note 7.** Regulation is measured at constant junction temperature by using a 2ms current pulse. Devices are tested for load regulation in the load range from 10mA to 500mA.

**Typical Operating Characteristics**

( $C_{IN} = C_{OUT} = 1\mu F/X7R$ ,  $C_{SS} = 1nF$ , unless otherwise specified)

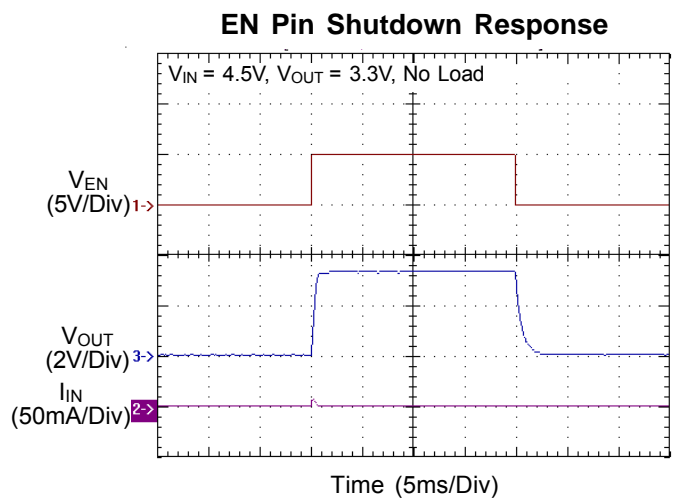
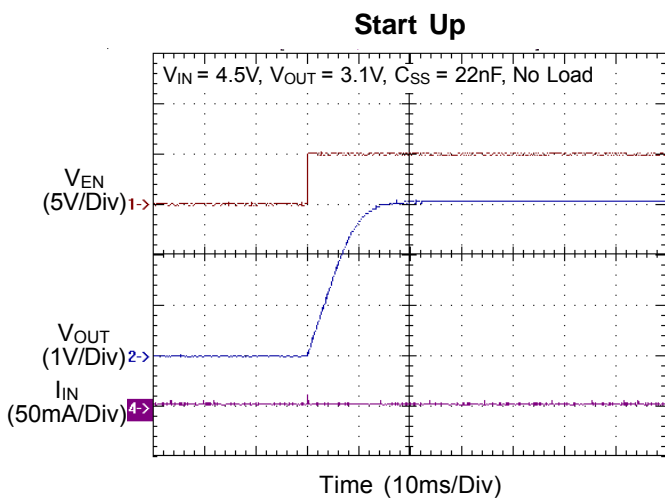
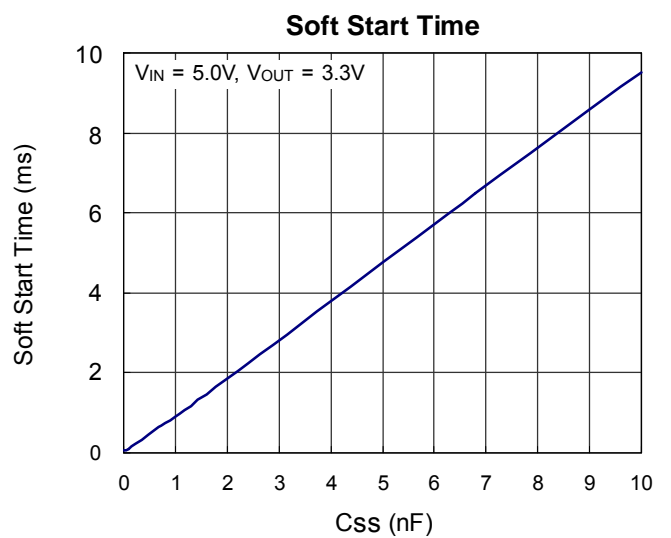
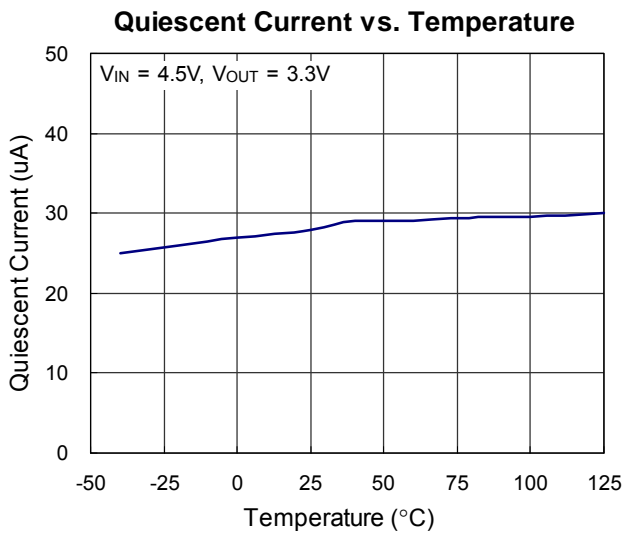
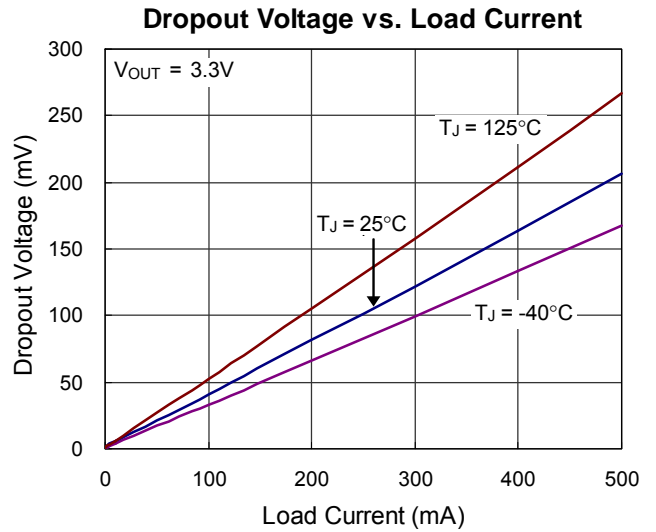
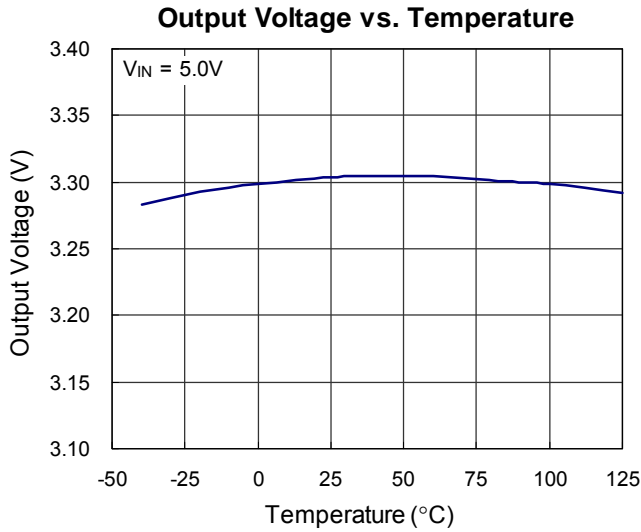

Load Transient Response

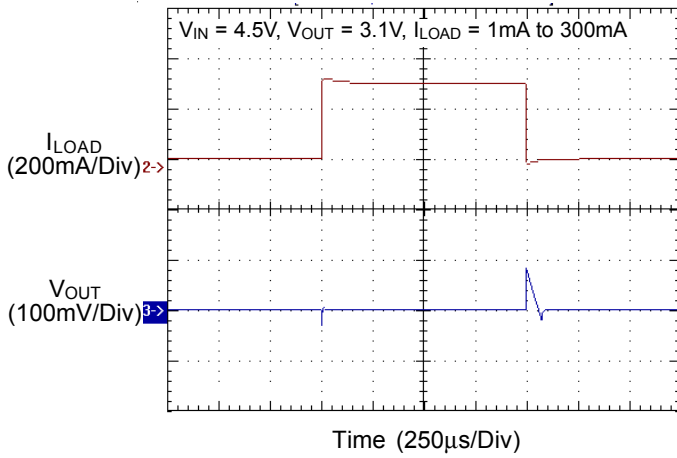

Load Transient Response

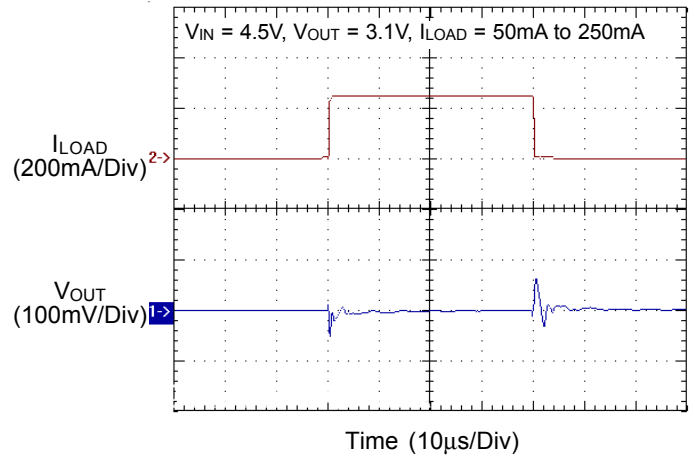

Line Transient Response

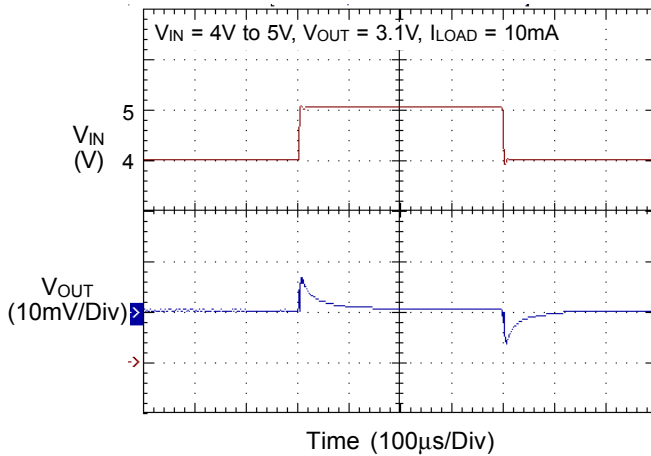

Line Transient Response

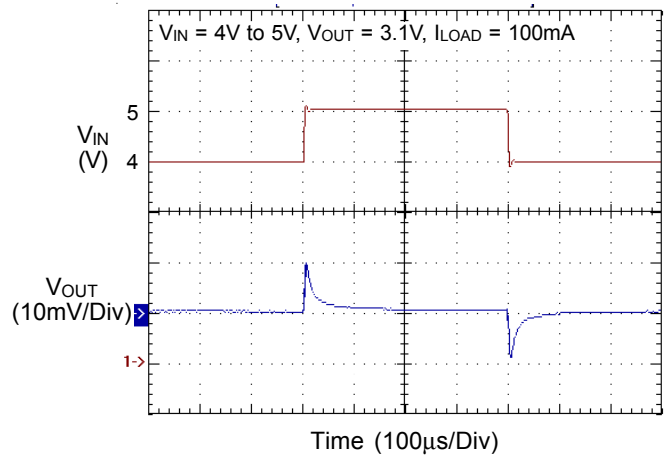

PSRR

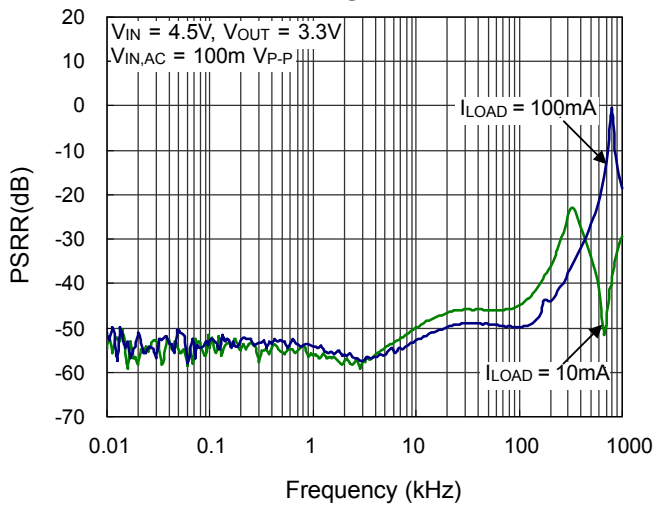

Noise

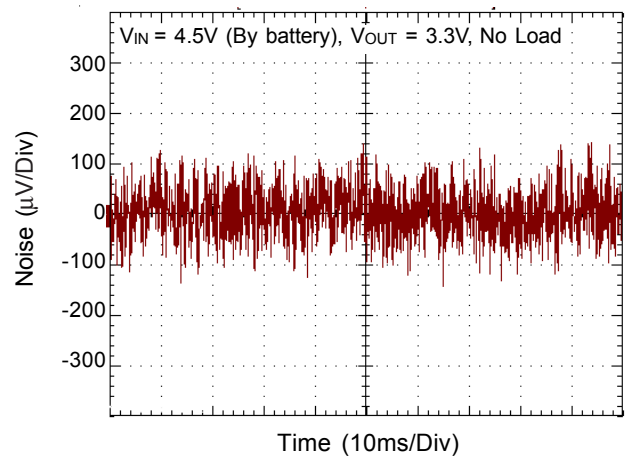

## Applications Information

Like any low-dropout regulator, the external capacitors used with the RT9020 must be carefully selected for regulator stability and performance. The recommended input and output capacitors should be 1μF or greater X7R/X5R ceramic. The input capacitor must be located a distance not more than 0.5 inch from the input pin of the IC and returned to a clean analog ground. The capacitor with larger value and lower ESR (equivalent series resistance) provides better PSRR and line-transient response.

The output capacitor must meet both requirements for minimum amount of capacitance and ESR in all LDOs application. The RT9020 is designed specifically to work with low ESR ceramic output capacitor in space-saving and performance consideration. Using a ceramic capacitor whose value is at least 1μF with ESR > 20mΩ on the RT9020 output ensures stability. The RT9020 still works well with output capacitor of other types due to the wide stable ESR range. Figure 1. shows the curves of allowable ESR range as a function of load current for various output capacitor values. Output capacitor of larger capacitance can reduce noise and improve load transient response, stability, and PSRR. The output capacitor should be located not more than 0.5 inch from the VOUT pin of the RT9020 and returned to a clean analog ground.

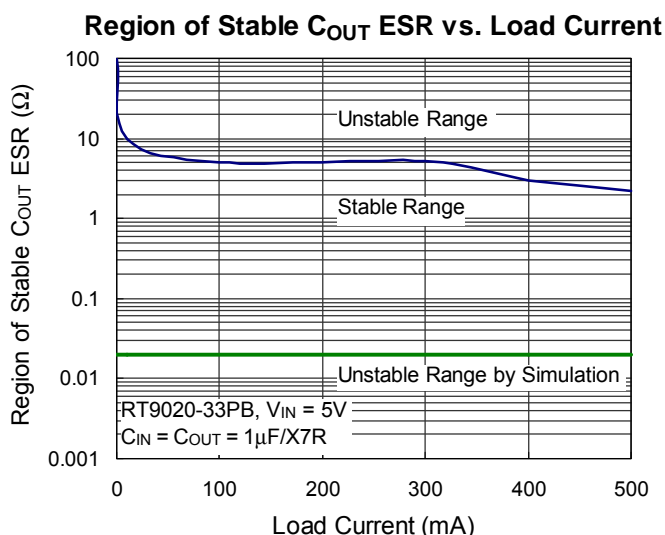

Figure 1

### Enable

The RT9020 goes into shutdown mode when the EN pin is in a logic low condition. During this condition, the RT9020 has an EN pin to turn on or turn off regulator, When the EN pin is logic high, the regulator will be turned on. The supply current in shutdown mode is as low as 0.7μA typically. The EN pin may be directly tied to V<sub>IN</sub> to keep the part on.

### PSRR

The power supply rejection ratio (PSRR) is defined as the gain from the input to output divided by the gain from the supply to the output. The PSRR is found to be

$$PSRR = 20 \times \log \left( \frac{\Delta \text{Gain Error}}{\Delta \text{Supply}} \right)$$

Note that when heavy load measuring, Δsupply will cause Δtemperature. And Δtemperature will cause Δoutput voltage change. So the heavy load PSRR measuring includes temperature effect.

### Current limit

The RT9020 contains an independent current limiter, which monitors and controls the pass transistor's gate voltage, limiting the output current to 0.7A (typ.). The output can be shorted to ground indefinitely without damaging the part.

### Thermal Considerations

Thermal protection limits power dissipation in RT9020. When the operation junction temperature exceeds 170°C, the OTP circuit starts the thermal shutdown function and turns the pass element off. The pass element turn on again after the junction temperature cools by 30°C.

For continuous operation, do not exceed absolute maximum operation junction temperature 125°C. The power dissipation definition in device is :

$$P_D = (V_{IN} - V_{OUT}) \times I_{OUT} + V_{IN} \times I_Q$$

The maximum power dissipation depends on the thermal resistance of IC package, PCB layout, the rate of surroundings airflow and temperature difference between junction to ambient. The maximum power dissipation can

be calculated by following formula :

$$P_{D(MAX)} = (T_{J(MAX)} - T_A) / \theta_{JA}$$

Where  $T_{J(MAX)}$  is the maximum operation junction temperature,  $T_A$  is the ambient temperature and the  $\theta_{JA}$  is the junction to ambient thermal resistance.

For recommended operating conditions specification, where  $T_{J(MAX)}$  is the maximum junction temperature of the die (125°C) and  $T_A$  is the operated ambient temperature. The junction to ambient thermal resistance  $\theta_{JA}$  ( $\theta_{JA}$  is layout dependent) for SOT-23-5 package is 250°C/W and SC-70-5 package is 333°C/W on the standard JEDEC 51-3 single-layer thermal test board. The maximum power dissipation at  $T_A = 25^\circ\text{C}$  can be calculated by following formula :

$$P_{D(MAX)} = (125^\circ\text{C} - 25^\circ\text{C}) / 250 = 0.400\text{W for SOT-23-5 packages}$$

$$P_{D(MAX)} = (125^\circ\text{C} - 25^\circ\text{C}) / 333 = 0.300\text{W for SC-70-5 packages}$$

The maximum power dissipation depends on operating ambient temperature for fixed  $T_{J(MAX)}$  and thermal resistance  $\theta_{JA}$ . The Figure 2 of derating curves allows the designer to see the effect of rising ambient temperature on the maximum power allowed.

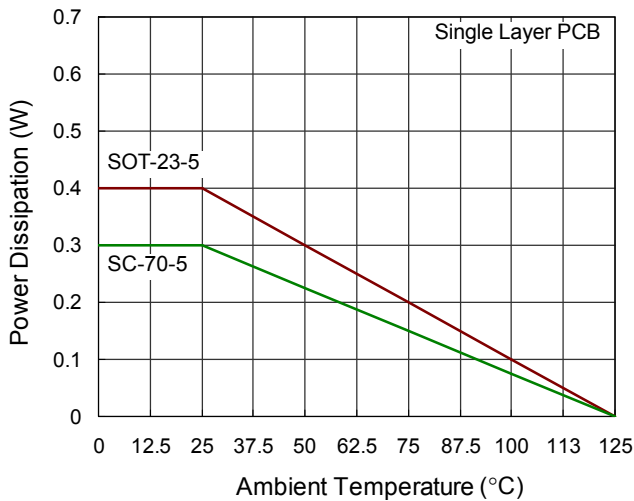
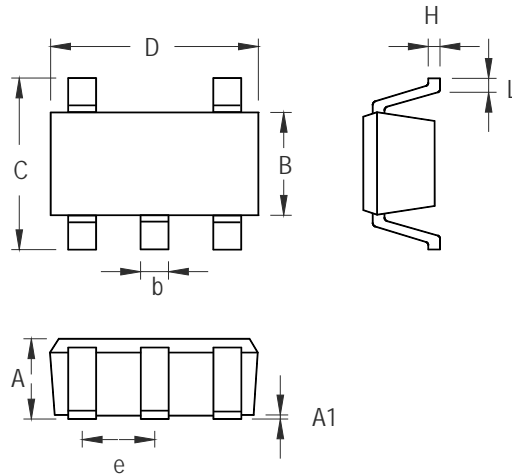

Figure 2. Derating Curve of Maximum Power Dissipation

**Outline Dimension**



Symbol	Dimensions In Millimeters		Dimensions In Inches	
	Min	Max	Min	Max
A	0.889	1.295	0.035	0.051
A1	0.000	0.152	0.000	0.006
B	1.397	1.803	0.055	0.071
b	0.356	0.559	0.014	0.022
C	2.591	2.997	0.102	0.118
D	2.692	3.099	0.106	0.122
e	0.838	1.041	0.033	0.041
H	0.080	0.254	0.003	0.010
L	0.300	0.610	0.012	0.024

**SOT-23-5 Surface Mount Package**

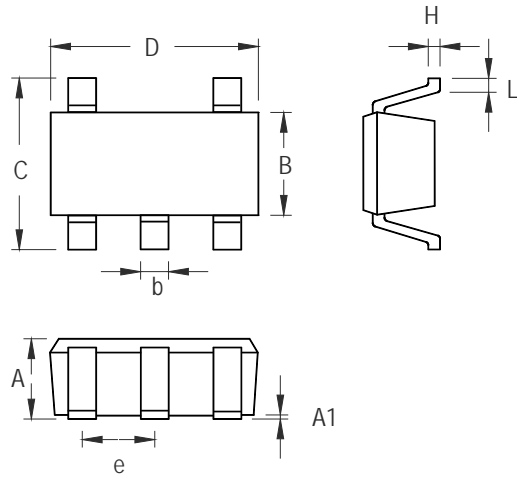

Symbol	Dimensions In Millimeters		Dimensions In Inches	
	Min	Max	Min	Max
A	0.800	1.100	0.031	0.044
A1	0.000	0.100	0.000	0.004
B	1.150	1.350	0.045	0.054
b	0.150	0.400	0.006	0.016
C	1.800	2.450	0.071	0.096
D	1.800	2.250	0.071	0.089
e	0.650		0.026	
H	0.080	0.260	0.003	0.010
L	0.210	0.460	0.008	0.018

**SC-70-5 Surface Mount Package**

**Richtek Technology Corporation**

14F, No. 8, Tai Yuen 1<sup>st</sup> Street, Chupei City  
 Hsinchu, Taiwan, R.O.C.  
 Tel: (8863)5526789

Richtek products are sold by description only. Richtek reserves the right to change the circuitry and/or specifications without notice at any time. Customers should obtain the latest relevant information and data sheets before placing orders and should verify that such information is current and complete. Richtek cannot assume responsibility for use of any circuitry other than circuitry entirely embodied in a Richtek product. Information furnished by Richtek is believed to be accurate and reliable. However, no responsibility is assumed by Richtek or its subsidiaries for its use; nor for any infringements of patents or other rights of third parties which may result from its use. No license is granted by implication or otherwise under any patent or patent rights of Richtek or its subsidiaries.

## Looking for pricing, stock, or lifecycle information?

Click below to explore more details on WIN SOURCE:

- [View RT9020-31GB on WIN SOURCE](#)
- [Richtek USA Inc. Information](#)

## Optimize Your Supply Chain with WIN SOURCE Solutions

- ✓ Global Sourcing Solution
- ✓ Obsolete Management
- ✓ Cost Control Management
- ✓ Shortage Management
- ✓ Alternative Solution
- ✓ Excess Inventory Management