



**THE DATASHEET OF
DSF106Q3R0**





FEATURES

High Voltage – Very Fast Charge/Discharge – High Power Density –
Lower ESR
RoHS Compliant

APPLICATIONS

Battery Backup/Alternative – Pulse Power – Energy Harvesting – LED Displays – Mechanical Actuators – Audio Systems

Operating Temperature Range		-40°C to +65°C (-40 to +85°C @ 2.5V)	
Storage Temperature		-40°C to +70°C	
Capacitance Tolerance @ 20°C		+30%/-10% (Q tolerance)	
Voltage	WVDC	3	
	SVDC	3.2	
Life Time		1000 hours with rated voltage applied at 65°C	
		Capacitance change	±30% of initially measured values
		ESR	<200% of initially specified values
		Leakage current	≤100% specified maximum value
Shelf Life		1000 hours with no voltage applied at 60°C	
		Capacitance change	±30% of initially measured values
		ESR	<200% of initially specified values
Life Cycles (25°C) 1 cycle= Charge to WVDC for 20s, constant voltage charging for 10s, discharge to ½ WVDC for 20s, rest for 10s		500,000 cycles	
		Capacitance change	±30% of initially measured values
		ESR change	<200% of initially specified values

D 8 to 18mm.

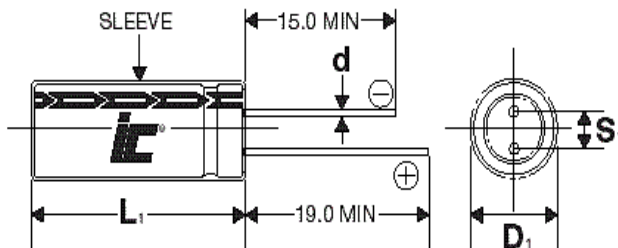

Lead spacing VS. Case diameter					
D	8	10	12.5	16	18
S	3.5	5.0	5.0	7.5	7.5
d	0.6	0.6	0.6	0.8	0.8
α	1.5	2.0	2.0	2.0	2.0

$L_1 = L + \alpha$ mm
 $D_1 = D + 0.5$ mm
 $S_1 = S \pm 0.5$ mm



Capacitance 100F and 200F

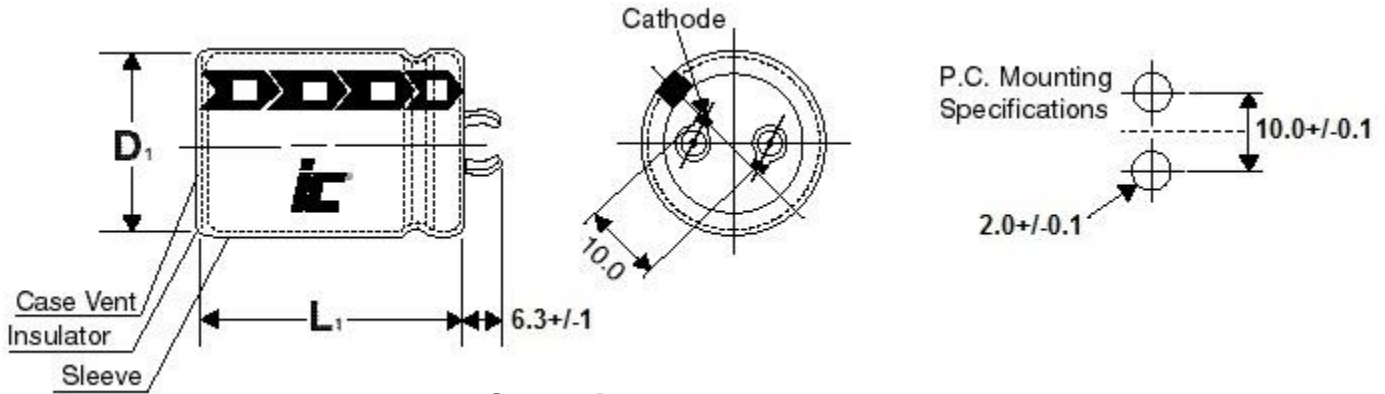

Capacitance 350F to 600F

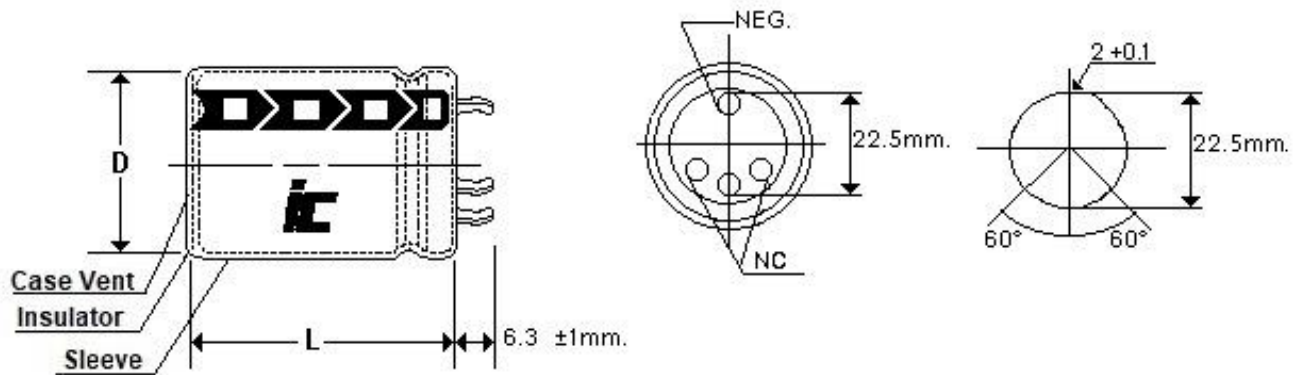

6 Volt Parts

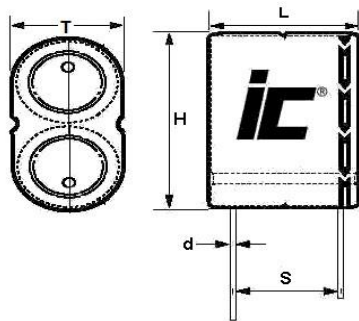

Capacitance (F)	Dims (LxHxT) (mm) +1.0mm	Lead spacing (S) (mm) +/-0.5mm	Lead diameter (d) (mm)
1.5	17x23x8.5	12	0.6
2.5	21x23x11	15.5	0.6
3.5	21x27x11	15.5	0.6
5	26x27x13	18	0.6

DSF

High pulse power, extends
battery life

WVDC	Capacitance (F)	IC PART NUMBER	Weight (grams)	Volume (mL)	Dims DxL LxHxT (mm)	Lead Spacing S (mm)	Lead Diameter d (mm)
3	3.0	DSF305Q3R0	1.4	1.01	8x20	3.5	0.6
3	5.0	DSF505Q3R0	2.1	1.57	10x20	5	0.6
3	7.0	DSF705Q3R0	2.3	1.96	10x25	5	0.6
3	10.0	DSF106Q3R0	3.2	2.36	10x30	5	0.6
3	25.0	DSF256Q3R0	7	5.03	16x25	7.5	0.8
3	50.0	DSF506Q3R0	12.8	10.18	18x40	7.5	0.8
3	100.0	DSF107Q3R0	20	17.11	22x45	10	1.2
3	110.0	DSF117Q3R0	22	15.27	18x60	7.5	0.8
3	200.0	DSF207Q3R0	36	35.34	30x50	10	1.2
3	350.0	DSF357Q3R0	64	57.73	35x60	22.5	1.2
3	400.0	DSF407Q3R0	70	57.73	35x60	22.5	1.2
3	470.0	DSF477Q3R0	70	57.73	35x60	22.5	1.2
3	600.0	DSF607Q3R0	82	67.35	35x70	22.5	1.2
6	1.5	DSF155Q6R0HAE	3	2.97	17x23x8.5	12	0.6
6	2.5	DSF255Q6R0JBE	5.2	4.97	21x23x11	15.5	0.6
6	3.5	DSF355Q6R0JBF	6	5.83	21x27x11	15.5	0.6
6	5.0	DSF505Q6R0JBG	8.3	6.91	21x32x11	18	0.6



DSF

High pulse power, extends battery life

WVDC	Capacitance (F)	IC PART NUMBER	MAX Current (A) (1 Sec.)	Maximum Continuous Current (A) ($\Delta T=15^{\circ}C$)	Short Circuit Current (A)	ESR AC 1 kHz (m Ω)	DC ESR (m Ω) 20°C	Max stored energy (mWh)	LC (mA), (72 hrs)	Energy Density (Wh/kg)	Energy Volumetric Density (Wh/l)	Power Density (kW/kg)	Power Volumetric Density (kW/l)
3	3.0	DSF305Q3R0	3.1	1.4	20	80	150	3.75	0.014	2.67	3.71	5.14	6.6
3	5.0	DSF505Q3R0	4.5	2.2	23	70	130	6.25	0.02	2.97	3.98	3.95	5.29
3	7.0	DSF705Q3R0	6.7	2.4	38	55	80	8.75	0.03	3.8	4.46	5.86	6.88
3	10.0	DSF106Q3R0	9.4	3.4	50	40	60	12.5	0.045	3.9	5.29	5.625	7.62
3	25.0	DSF256Q3R0	20	4.4	86	25	35	31.25	0.1	4.46	6.21	4.4	6.13
3	50.0	DSF506Q3R0	35.7	7.1	136	15	22	62.5	0.15	4.88	6.14	3.83	4.82
3	100.0	DSF107Q3R0	68.2	8.3	250	8	12	125	0.3	5.95	7.31	4.29	5.26
3	110.0	DSF117Q3R0	59.8	6.3	188	10	16	137.5	0.21	6.25	9.005	3.07	4.421
3	200.0	DSF207Q3R0	100	10	300	6	10	250	0.7	6.94	7.07	3	3.06
3	350.0	DSF357Q3R0	236	18.9	857	3	3.5	437.5	1	6.73	7.58	4.75	5.35
3	400.0	DSF407Q3R0	250	18.9	857	3	3.5	500	1	7.35	8.66	4.96	5.85
3	470.0	DSF477Q3R0	267	18.9	857	3	3.5	587.5	1.3	8.05	10.18	4.23	5.35
3	600.0	DSF607Q3R0	290	20	857	3	3.5	750	1.5	9.15	11.14	4.12	5.35
6	1.5	DSF155Q6R0HAE	3.1	1.4	20	180	320	7.5	0.013	2.5	2.52	16.6	16.8
6	2.5	DSF255Q6R0JBE	4.5	2.2	23	160	280	12.5	0.018	3.1	2.51	14.1	11.3
6	3.5	DSF355Q6R0JBF	6.7	2.4	38	130	180	17.5	0.025	3.5	3	13.8	11.9
6	5.0	DSF505Q6R0JBG	9.4	3.4	50	100	140	25	0.04	3.57	3.62	12.9	13

Looking for pricing, stock, or lifecycle information?

Click below to explore more details on WIN SOURCE:

-  [View DSF106Q3R0 on WIN SOURCE](#)
-  [Cornell Dubilier Electronics \(CDE\) Information](#)

Optimize Your Supply Chain with WIN SOURCE Solutions

-  Global Sourcing Solution
-  Obsolete Management
-  Cost Control Management
-  Shortage Management
-  Alternative Solution
-  Excess Inventory Management