

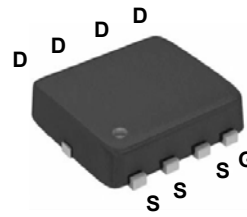


# THE DATASHEET OF SSFN3903

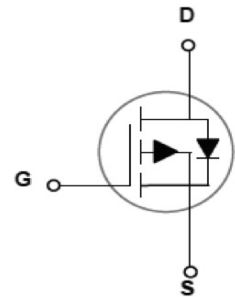


**Main Product Characteristics**

$V_{BDSS}$	-30V
$R_{DS(ON)}$	8.5mΩ
$I_D$	-50A



PPAK3x3



Schematic Diagram

**Features and Benefits**

- Advanced MOSFET process technology
- Ideal for DC-DC converter, power management in portable battery, computer, printer, cellular and general purpose applications
- Low on-resistance with low gate charge
- Fast switching and reverse body recovery



**Description**

The SSFN3903 utilizes the latest techniques to achieve high cell density and low on-resistance. These features make this device extremely efficient and reliable for use in high efficiency switch mode power supplies and a wide variety of other applications.

**Absolute Maximum Ratings** ( $T_C=25^{\circ}C$  unless otherwise specified)

Parameter	Symbol	Max.	Unit
Drain-Source Voltage	$V_{DS}$	-30	V
Gate-Source Voltage	$V_{GS}$	±20	V
Drain Current-Continuous ( $T_C=25^{\circ}C$ )	$I_D$	-50	A
Drain Current-Continuous ( $T_C=100^{\circ}C$ )		-32	
Drain Current-Pulsed <sup>1</sup>	$I_{DM}$	-200	A
Power Dissipation ( $T_A=25^{\circ}C$ )	$P_D$	2.2	W
Power Dissipation ( $T_A=70^{\circ}C$ )		1.3	W
Power Dissipation ( $T_C=25^{\circ}C$ )		59	W
Power Dissipation - Derate above 25°C		0.47	W/°C
Operating Junction Temperature Range	$T_J$	-55 To +150	°C
Storage Temperature Range	$T_{STG}$	-55 To +150	°C

**Thermal Characteristics**

Thermal Resistance, Junction-to-Ambient	$R_{\theta JA}$	62	°C/W
Thermal Resistance, Junction-to-Case	$R_{\theta JC}$	2.1	°C/W

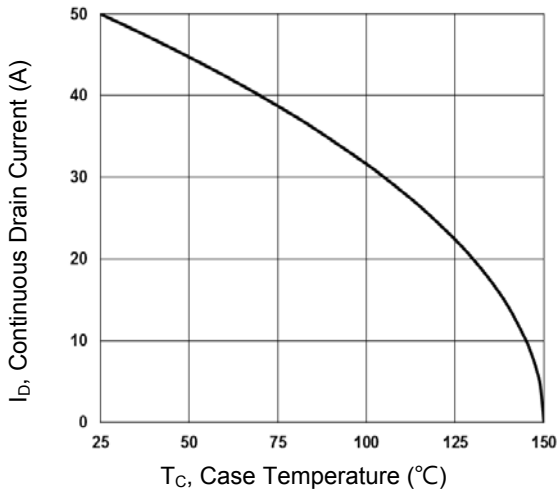
### Electrical Characteristics (T<sub>J</sub>=25°C unless otherwise specified)

Parameter	Symbol	Conditions	Min.	Typ.	Max.	Unit
<b>Off Characteristics</b>						
Drain-Source Breakdown Voltage	BV <sub>DSS</sub>	V <sub>GS</sub> =0V, I <sub>D</sub> =-250uA	-30	---	---	V
BV <sub>DSS</sub> Temperature Coefficient	$\Delta BV_{DSS}/\Delta T_J$	Reference to 25°C, I <sub>D</sub> =-1mA	---	-0.03	---	V/°C
Drain-Source Leakage Current	I <sub>DSS</sub>	V <sub>DS</sub> =-30V, V <sub>GS</sub> =0V, T <sub>J</sub> =25°C	---	---	-1	uA
		V <sub>DS</sub> =-24V, V <sub>GS</sub> =0V, T <sub>J</sub> =125°C	---	---	-10	uA
Gate-Source Leakage Current	I <sub>GSS</sub>	V <sub>GS</sub> =±20V, V <sub>DS</sub> =0V	---	---	±100	nA
<b>On Characteristics</b>						
Static Drain-Source On-Resistance	R <sub>DS(ON)</sub>	V <sub>GS</sub> =-10V, I <sub>D</sub> =-10A	---	7.1	8.5	mΩ
		V <sub>GS</sub> =-4.5V, I <sub>D</sub> =-8A	---	11.5	14	mΩ
Gate Threshold Voltage	V <sub>GS(th)</sub>	V <sub>GS</sub> =V <sub>DS</sub> , I <sub>D</sub> =-250uA	-1.2	-1.6	-2.5	V
V <sub>GS(th)</sub> Temperature Coefficient	$\Delta V_{GS(th)}$		---	4	---	mV/°C
Forward Transconductance	g <sub>fs</sub>	V <sub>DS</sub> =-10V, I <sub>D</sub> =-10A	---	14	---	S
<b>Dynamic and Switching Characteristics</b>						
Total Gate Charge <sup>2, 3</sup>	Q <sub>g</sub>	V <sub>DS</sub> =-15V, V <sub>GS</sub> =-4.5V, I <sub>D</sub> =-10A	---	35	56	nC
Gate-Source Charge <sup>2, 3</sup>	Q <sub>gs</sub>		---	10.8	16	nC
Gate-Drain Charge <sup>2, 3</sup>	Q <sub>gd</sub>		---	10.6	16	nC
Turn-On Delay Time <sup>2, 3</sup>	T <sub>d(on)</sub>	V <sub>DD</sub> =-15V, V <sub>GS</sub> =-10V, R <sub>G</sub> =6Ω, I <sub>D</sub> =-1A	---	24.5	38	ns
Rise Time <sup>2, 3</sup>	T <sub>r</sub>		---	10.5	16	ns
Turn-Off Delay Time <sup>2, 3</sup>	T <sub>d(off)</sub>		---	156.8	230	ns
Fall Time <sup>2, 3</sup>	T <sub>f</sub>		---	50	75	ns
Input Capacitance	C <sub>iss</sub>	V <sub>DS</sub> =-15V, V <sub>GS</sub> =0V, F=1MHz	---	3300	4800	pF
Output Capacitance	C <sub>oss</sub>		---	410	700	pF
Reverse Transfer Capacitance	C <sub>rss</sub>		---	280	500	pF
Gate Resistance	R <sub>g</sub>	V <sub>GS</sub> =0V, V <sub>DS</sub> =0V, F=1MHz	---	8.5	12	Ω
<b>Drain-Source Diode Characteristics and Maximum Ratings</b>						
Continuous Source Current	I <sub>S</sub>	V <sub>G</sub> =V <sub>D</sub> =0V, Force Current	---	---	-50	A
Pulsed Source Current	I <sub>SM</sub>		---	---	-100	A
Diode Forward Voltage	V <sub>SD</sub>	V <sub>GS</sub> =0V, I <sub>S</sub> =-1A, T <sub>J</sub> =25°C	---	---	-1	V

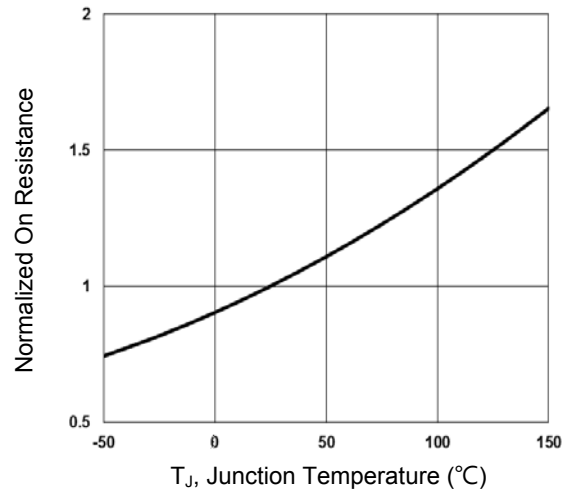
Notes :

1. Repetitive Rating: Pulsed width limited by maximum junction temperature.
2. The data tested by pulsed, pulse width ≤ 300us, duty cycle ≤ 2%.
3. Essentially independent of operating temperature.

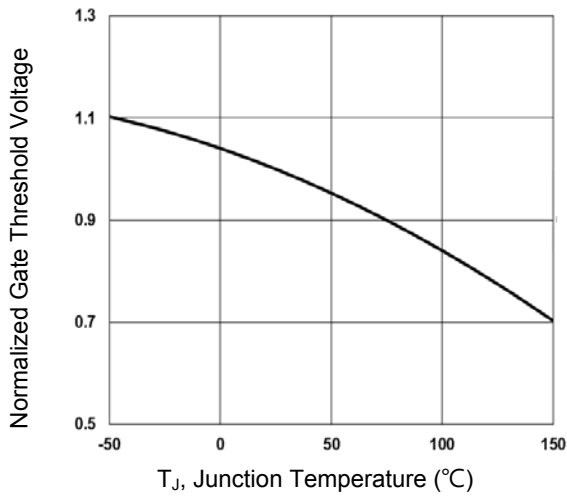
**Typical Electrical and Thermal Characteristics**



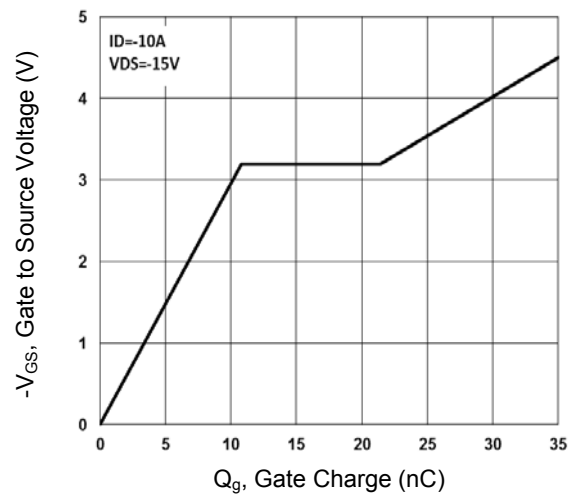
**Figure 1. Continuous Drain Current vs.  $T_C$**



**Figure 2. Normalized  $R_{DS(ON)}$  vs.  $T_J$**

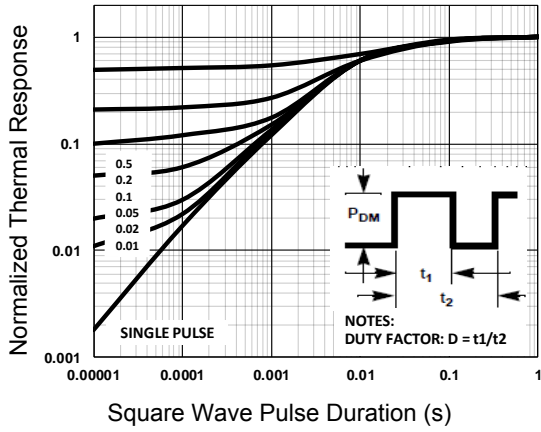


**Figure 3. Normalized  $V_{th}$  vs.  $T_J$**

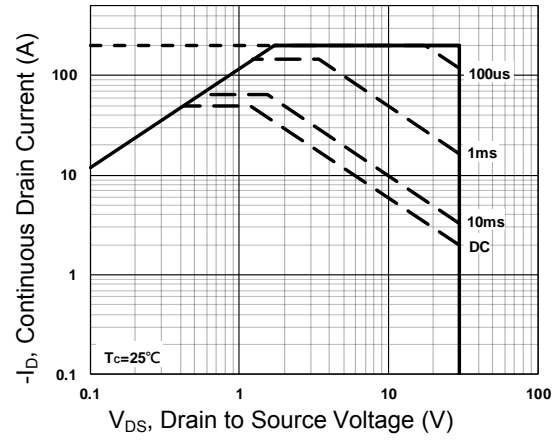


**Figure 4. Gate Charge Waveform**

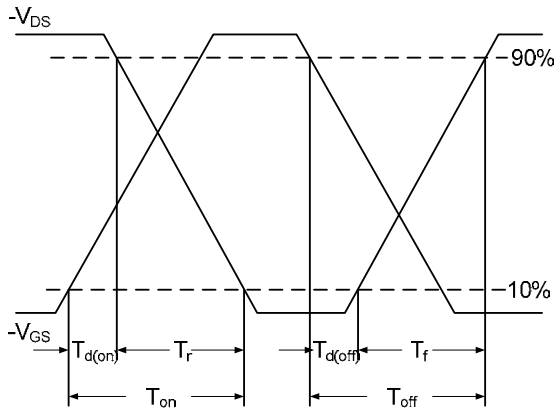
**Typical Electrical and Thermal Characteristics**



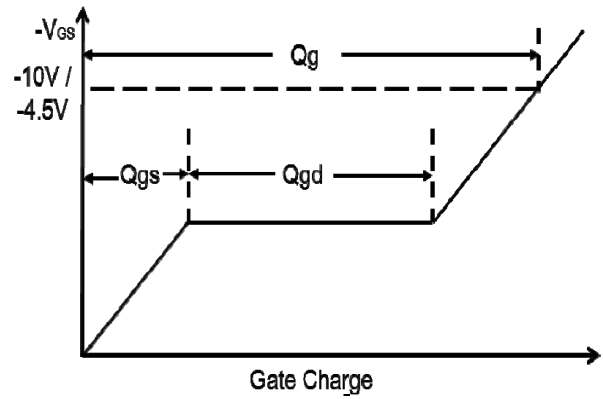
**Figure 5. Normalized Transient Impedance**



**Figure 6. Maximum Safe Operation Area**

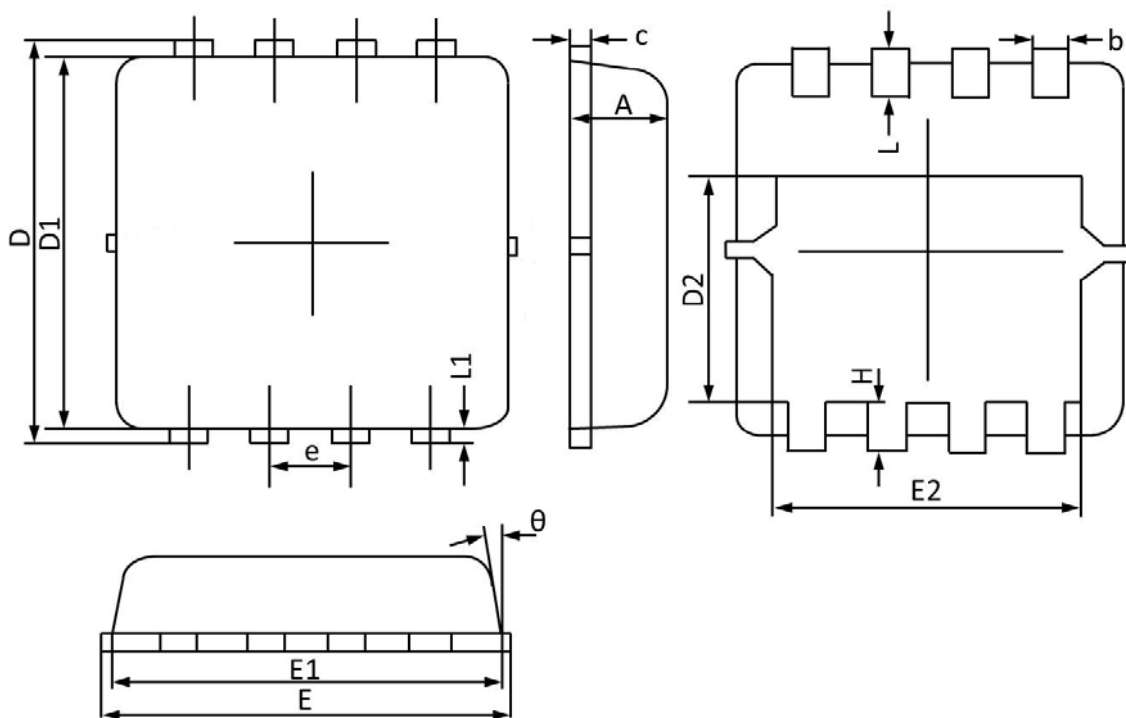


**Figure 7. Switching Time Waveform**



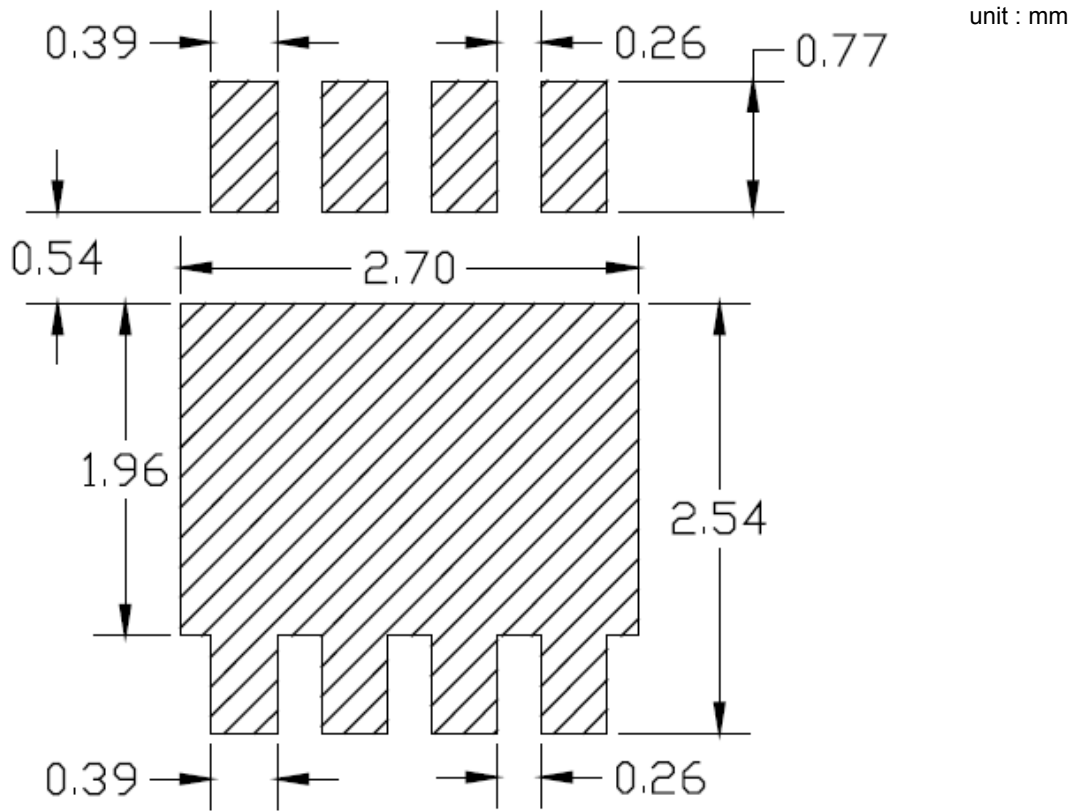
**Figure 8. Gate Charge Waveform**

**Package Outline Dimensions (PPAK3x3)**





Symbol	Dimensions In Millimeters		Dimensions In Inches	
	Min	Max	Min	Max
A	0.700	0.900	0.028	0.035
b	0.250	0.350	0.010	0.014
c	0.100	0.250	0.004	0.010
D	3.050	3.500	0.120	0.138
D1	2.900	3.200	0.114	0.126
D2	1.350	1.950	0.053	0.077
E	3.000	3.400	0.118	0.134
E1	2.900	3.300	0.114	0.130
E2	2.350	2.600	0.093	0.102
e	0.65 BSC		0.026 BSC	
H	0.300	0.750	0.012	0.030
L	0.300	0.600	0.012	0.024
L1	0.060	0.200	0.002	0.008
θ	6°	14°	6°	14°

**Suggested Pad Layout**



## Looking for pricing, stock, or lifecycle information?

Click below to explore more details on WIN SOURCE:

-  [View SSFN3903](#) on WIN SOURCE
-  [GOOD-ARK Electronics](#) Information

## Optimize Your Supply Chain with WIN SOURCE Solutions

-  Global Sourcing Solution
-  Obsolete Management
-  Cost Control Management
-  Shortage Management
-  Alternative Solution
-  Excess Inventory Management