



**THE DATASHEET OF  
SB5032-201-0**



# Shock Block - GFCI / SPGFCI / EGFPD

## SB5000 Series

Industrial Shock Block for Personnel Protection



\*For Polycarbonate 32 A and 60 A only



## Description

### Special-Purpose Ground-Fault Circuit Interrupter (SPGFCI), Class C and Class D

The Industrial Shock Block® SB5000 series is a personnel protection device designed to meet the requirements for special-purpose GFCIs defined by UL 943C. This standard outlines GFCI classes specifically designed for use in industrial facilities. Class C GFCIs are intended to be used on three-phase systems where the line-to-line voltage is 480 V or less with a trip level of 20 mA, while Class D GFCIs are intended to be used on 600 V systems. The SB5000 includes DFT harmonic filtering, an automatic self-test feature, and is compliant to the UL 1998 Software in Programmable Components standard.

### Ground-Fault Circuit Interrupter (GFCI), Class A

The SB5000 is available as a 208 or 240 V Class A GFCI, allowing commercial kitchens, vehicle service centers, and other non-dwelling applications to meet NEC 210.8(B) for their three-phase loads up to 100 A.

### Equipment Ground-Fault Protective Device (EGFPD)

The SB5000 is also available with adjustable protection settings as an EGFPD. The EGFPD models can be set to trip at 6 mA or from 10–100 mA in increments of 10 mA. This offers more flexibility since GFCI and SPGFCI devices are not permitted to have an adjustable trip level.

### Ratings and Models

The SB5000 is available for three-phase voltages from 208 to 600 V with a maximum full load current up to 100 A. The power system can be either solidly or high-resistance grounded, and the load must be single-phase or three-phase as long as the load does not require a neutral. The standard enclosure is IP 69K/NEMA 4X and outdoor rated, suitable for all industrial environments including high temperature washdown used in food production applications. The 32 and 60A models are also available in a hygienic stainless steel enclosure, with a 10 degree sloped top and FDA compliant silicone gasket, designed to facilitate sanitation in food processing facilities and the like.

### Grounding Monitor / Interrupter (GMI)

The SB5000 also monitors the equipment grounding connection between the Shock Block and load. This is a required feature for Class C and D GFCI devices and is recommended for Class A GFCI and EGFPD devices. If the ground-return path is broken, the SB5000 will trip and provide an alarm by changing the state of the alarm contacts. This monitoring circuit requires an extra (pilot) wire between the SB5000 and the load. At the load, the pilot wire is connected to a termination device. The other end of the termination device is connected to the equipment ground (typically the enclosure).

# Shock Block - GFCI / SPGFCI / EGFPD

## SB5000 Series

### Features & Benefits

FEATURES	BENEFITS
<b>UL 943 inverse time trip curve</b>	Inverse time detection circuit protects people while also reducing the probability of nuisance tripping
<b>DFT (Discrete Fourier Transform) filtering algorithm</b>	Eliminates nuisance trips due to harmonics
<b>Minimum trip time &lt;20 msec</b>	Reduces the risk of ventricular fibrillation for leakage current of 250 mA and above
<b>Fixed 6 mA (UL 943) or 20 mA (UL 943C) trip level</b>	UL Listed GFCI and Special-Purpose GFCI personnel protection for industrial and commercial loads up to 100 A (GFCI versions)
<b>Selectable trip levels 6–100 mA</b>	Settings below 20 mA provide extra safety. The settings above 20 mA can reduce nuisance tripping on systems with high-leakage current (EGFPD versions)
<b>Two-stage ground monitor with Zener termination that meets UL 943C, CSA M421</b>	Proactively protects from shock by tripping if continuity of ground wire between SB5000 and equipment is compromised
<b>Flexible configuration</b>	Selectable manual reset or auto-reset for brownout, power-up, and ground monitor interruptions to fit plant safety protocols
<b>Conformal coating</b>	Equipped with conformally coated circuit boards to protect against corrosion and moisture
<b>Auxiliary contact</b>	Alerts your SCADA system if the SB5000 is energized or tripped
<b>Automatic self-test</b>	The SB5000 will continuously test itself and will trip if there is an internal failure
<b>GFCI Class A, C, D, and EGFPD options in one series</b>	Simplified planning and operator familiarity for multiple applications/requirements

### Applications

- For applications where people, electrical equipment, and water are present
- Agriculture
- Amusement parks
- Commercial kitchens
- Construction
- Food and beverage
- Horticultural lighting
- Maintenance shops
- Manufacturing
- Mining
- Oil and gas
- Pools, spas, fountains, water features
- Vehicle service centers
- Water/wastewater

### Specifications

<b>Voltage Rating</b>	208 V, 240 V, 480 V, 600 V
<b>Current Rating</b>	32, 60, 80, or 100 A
<b>System Type</b>	Three-phase, 3-wire (no neutral), 60 Hz; Single-phase, 2-wire (no neutral), 60 Hz; Single-phase, 3-wire (with neutral), 60 Hz for EGFPD versions only
<b>Short-Circuit Current Rating</b>	10,000 A (for SB5032 and SB5060); 50,000A (for SB5080 and SB5100)
<b>Trip Level Settings</b>	Fixed at 6 mA (Class A models); Fixed at 20 mA (Class C/D models) Selectable 6, 10, 20, 30, 40, 50, 60, 70, 80, 90, 100 mA (EGFPD models)
<b>Trip Time Setting</b>	Inverse time curve according to UL 943
<b>Ground Monitoring Circuit</b>	Selectable short or Zener termination; Fail-safe; CSA M421 compliant
<b>Enclosure</b>	Polycarbonate: IP 69K and NEMA 4X (Outdoor), Polycarbonate, Lockable Stainless Steel: IP 69K and NEMA 4X, AISI 304 steel, FDA compliant blue silicone gasket Stainless Steel: Class II, Division 2, Groups E, F, G for Hazardous Locations and T6 Temperature Code
<b>Operating Temperature</b>	-35 °C (-31 °F) to 40 °C (104 °F), up to 66 °C (151 °F) with derating
<b>Dimensions</b>	<b>H</b> 285.6 mm (11.25 in.); <b>W</b> 244.4 mm (9.62 in.); <b>D</b> 119.6 mm (4.71 in.) – for Polycarbonate 32 A and 60 A <b>H</b> 358.2 mm (14.10 in.); <b>W</b> 250.5 mm (9.86 in.); <b>D</b> 170 mm (6.69 in.) – for Stainless Steel 32 A and 60 A <b>H</b> 383.4 mm (15.09 in.); <b>W</b> 327.1 mm (12.88 in.); <b>D</b> 137.4 mm (5.5 in.) – for Polycarbonate 80 A and 100 A

# Shock Block - GFCI / SPGFCI / EGFPD

## SB5000 Series

### Accessories

- A 1N5339B Termination Device:** Axial-lead ground-check termination, included with SB5000 series
  - A SE-TA6 Termination Assembly:** Optional termination assembly with terminals and mounting holes
  - A SE-TA6-SM Stud-Mount Termination Assembly:** Optional ground-check termination for submersible pumps
  - A SE-TA6ASF-WL Series Termination Assembly:** Compact 12 W ground-check termination assembly
- AC5000-MNT-01:** Stainless steel mounting hardware, 1" hygienic spacer with FDA compliant gasket, threaded, (kit of 4)
- AC5000-MNT-02:** Stainless steel mounting brackets, flat, (kit of 4)
- AC5000-MNT-03:** Stainless steel mounting brackets, 1" standoff/offset, (kit of 4)

### Simplified Circuit Diagram

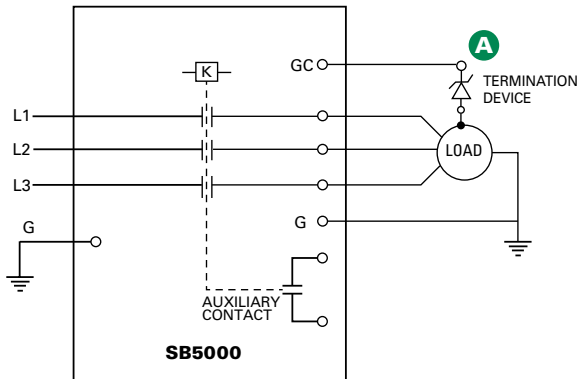

### Certification & Compliance

<b>UL Listed</b> (all models)	UL1998
<b>CSA</b> (SB5032, SB5060 polycarbonate models)	LR 53428
<b>cULus Listed</b>	Class A GFCI (UL 943) E330856 EGFPD (UL 943/UL 1053) E359574
<b>UL Listed</b>	Class C, D SPGFCI (UL 943C) E352763

### Ordering Information

#### Polycarbonate Enclosure

*GFCI (UL 943 CLASS A)			SPGFCI (UL 943C CLASS D)		
6mA Fixed Trip Level			20mA Fixed Trip Level		
Load Rating (A)	Voltage (V)	Ordering Number	Load Rating (A)	Voltage (V)	Ordering Number
32	208	SB5032-021-0	32	600	SB5032-301-0
60	208	SB5060-021-0	60	600	SB5060-301-0
80	208	SB5080-021-0	80	600	SB5080-301-0
80	240	SB5080-121-0	100	600	SB5100-301-0
100	208	SB5100-021-0			
100	240	SB5100-121-0			

\* Most Popular Models

# Shock Block - GFCI / SPGFCE / EGFPD

## SB5000 Series

### Ordering Information (Continued)

#### Polycarbonate Enclosure (Continued)

SPGFCE (UL 943C CLASS C)		
20mA Fixed Trip Level		
Load Rating (A)	Voltage (V)	Ordering Number
32	208	SB5032-001-0
32	480	SB5032-201-0
60	208	SB5060-001-0
60	480	SB5060-201-0
80	208	SB5080-001-0
80	240	SB5080-101-0
80	480	SB5080-201-0
100	208	SB5100-001-0
100	240	SB5100-101-0
100	480	SB5100-201-0

EGFPD (UL 943/1053 SELECTABLE)		
Adjustable Trip Level 6, 10-100mA		
Load Rating (A)	Voltage (V)	Ordering Number
32	208	SB5032-011-0
32	480	SB5032-211-0
32	600	SB5032-311-0
60	208	SB5060-011-0
60	480	SB5060-211-0
60	600	SB5060-311-0
80	208	SB5080-011-0
80	240	SB5080-111-0
80	480	SB5080-211-0
80	600	SB5080-311-0
100	208	SB5100-011-0
100	240	SB5100-111-0
100	480	SB5100-211-0
100	600	SB5100-311-0

#### Stainless Steel Enclosure

GFCI (UL 943 CLASS A)		
6mA Fixed Trip Level		
Load Rating (A)	Voltage (V)	Ordering Number
32	208	SB5032-022-0
60	208	SB5060-022-0

SPGFCE (UL 943C CLASS D)		
20mA Fixed Trip Level		
Load Rating (A)	Voltage (V)	Ordering Number
32	600	SB5032-302-0
60	600	SB5060-302-0

SPGFCE (UL 943C CLASS C)		
20mA Fixed Trip Level		
Load Rating (A)	Voltage (V)	Ordering Number
32	208	SB5032-002-0
32	480	SB5032-202-0
60	208	SB5060-002-0
60	480	SB5060-202-0

EGFPD (UL 943/1053 SELECTABLE)		
Adjustable Trip Level 6, 10-100mA		
Load Rating (A)	Voltage (V)	Ordering Number
32	208	SB5032-012-0
32	480	SB5032-212-0
32	600	SB5032-312-0
60	208	SB5060-012-0
60	480	SB5060-212-0
60	600	SB5060-312-0

#### Stainless Steel, Class II, Division 2 Enclosure

GFCI (UL 943 CLASS A)		
6mA Fixed Trip Level		
Load Rating (A)	Voltage (V)	Ordering Number
32	208	SB5032-023-0
60	208	SB5060-023-0

SPGFCE (UL 943C CLASS D)		
20mA Fixed Trip Level		
Load Rating (A)	Voltage (V)	Ordering Number
32	600	SB5032-303-0
60	600	SB5060-303-0

SPGFCE (UL 943C CLASS C)		
20mA Fixed Trip Level		
Load Rating (A)	Voltage (V)	Ordering Number
32	208	SB5032-003-0
32	480	SB5032-203-0
60	208	SB5060-003-0
60	480	SB5060-203-0

EGFPD (UL 943/1053 SELECTABLE)		
Adjustable Trip Level 6, 10-100mA		
Load Rating (A)	Voltage (V)	Ordering Number
32	208	SB5032-013-0
32	480	SB5032-213-0
32	600	SB5032-313-0
60	208	SB5060-013-0
60	480	SB5060-213-0
60	600	SB5060-313-0

# Shock Block - GFCI / SPGFCI / EGFPD

## SB5000 Series

### Dimensions Millimeters [inches]

#### SB5060

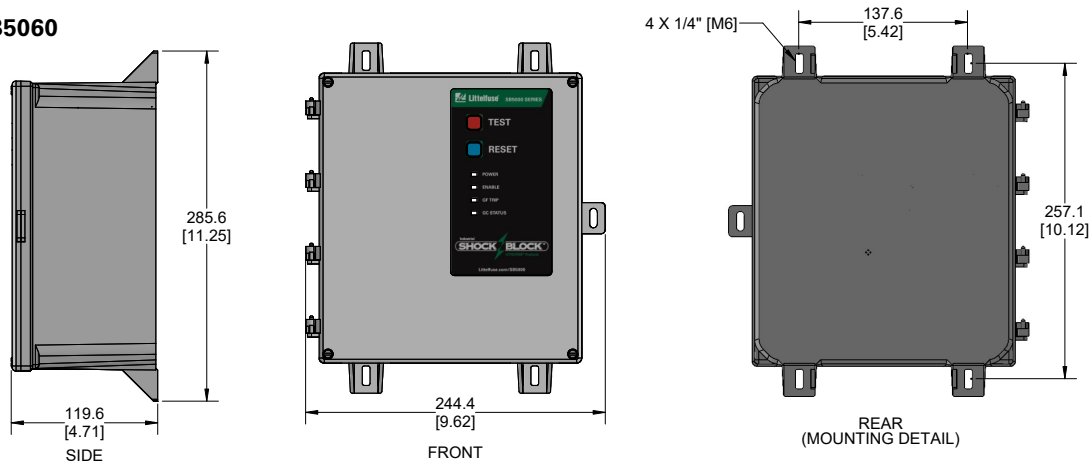

#### SB5100

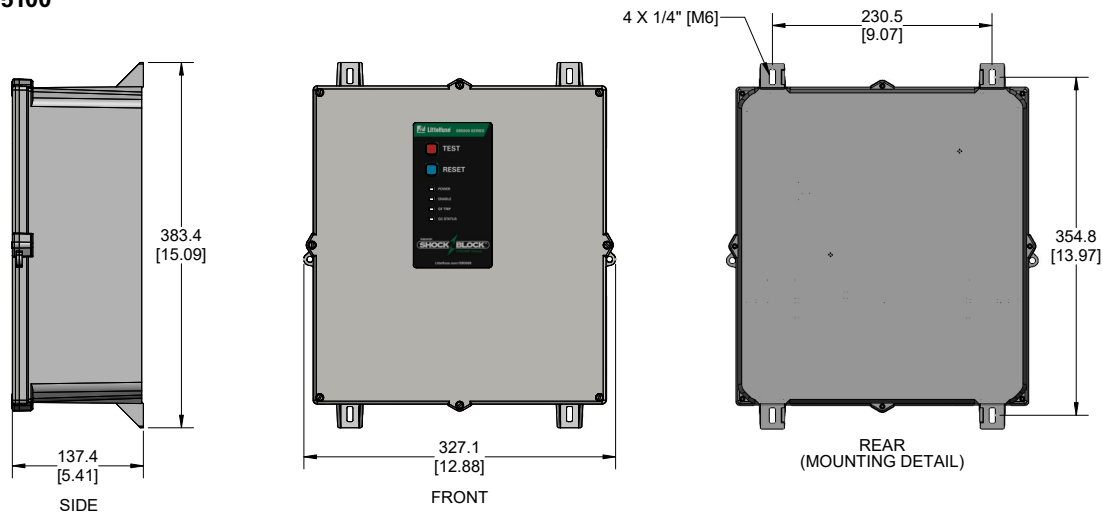

#### SB5060 Stainless Steel

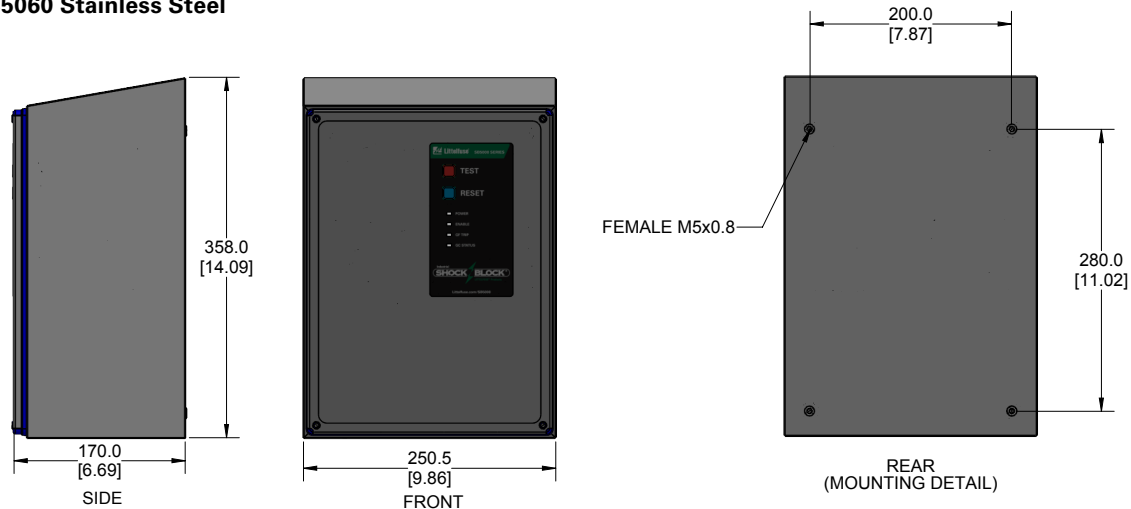

# Shock Block - GFCI / SPGFCI / EGFPD

## SB5000 Series

### Connection Diagram



The SB5000 is installed in-line between incoming power or existing overcurrent protection device and the load.



**Disclaimer Notice** – Information furnished is believed to be accurate and reliable. However, users should independently evaluate the suitability of and test each product selected for their own applications. Littelfuse products are not designed for, and may not be used in, all applications. Read complete Disclaimer Notice at [www.littelfuse.com/product-disclaimer](http://www.littelfuse.com/product-disclaimer).

## Looking for pricing, stock, or lifecycle information?

Click below to explore more details on WIN SOURCE:

-  [View SB5032-201-0 on WIN SOURCE](#)
-  [Littelfuse Inc. Information](#)

## Optimize Your Supply Chain with WIN SOURCE Solutions

-  Global Sourcing Solution
-  Obsolete Management
-  Cost Control Management
-  Shortage Management
-  Alternative Solution
-  Excess Inventory Management