



**THE DATASHEET OF
TLV320DAC23IGQER**



TLV320DAC23

***Stereo Audio D/A Converter, 8- to 96-kHz With
Integrated Headphone Amplifier***

Data Manual

IMPORTANT NOTICE

Texas Instruments Incorporated and its subsidiaries (TI) reserve the right to make corrections, modifications, enhancements, improvements, and other changes to its products and services at any time and to discontinue any product or service without notice. Customers should obtain the latest relevant information before placing orders and should verify that such information is current and complete. All products are sold subject to TI's terms and conditions of sale supplied at the time of order acknowledgment.

TI warrants performance of its hardware products to the specifications applicable at the time of sale in accordance with TI's standard warranty. Testing and other quality control techniques are used to the extent TI deems necessary to support this warranty. Except where mandated by government requirements, testing of all parameters of each product is not necessarily performed.

TI assumes no liability for applications assistance or customer product design. Customers are responsible for their products and applications using TI components. To minimize the risks associated with customer products and applications, customers should provide adequate design and operating safeguards.

TI does not warrant or represent that any license, either express or implied, is granted under any TI patent right, copyright, mask work right, or other TI intellectual property right relating to any combination, machine, or process in which TI products or services are used. Information published by TI regarding third-party products or services does not constitute a license from TI to use such products or services or a warranty or endorsement thereof. Use of such information may require a license from a third party under the patents or other intellectual property of the third party, or a license from TI under the patents or other intellectual property of TI.

Reproduction of information in TI data books or data sheets is permissible only if reproduction is without alteration and is accompanied by all associated warranties, conditions, limitations, and notices. Reproduction of this information with alteration is an unfair and deceptive business practice. TI is not responsible or liable for such altered documentation.

Resale of TI products or services with statements different from or beyond the parameters stated by TI for that product or service voids all express and any implied warranties for the associated TI product or service and is an unfair and deceptive business practice. TI is not responsible or liable for any such statements.

Following are URLs where you can obtain information on other Texas Instruments products and application solutions:

Products		Applications	
Amplifiers	amplifier.ti.com	Audio	www.ti.com/audio
Data Converters	dataconverter.ti.com	Automotive	www.ti.com/automotive
DSP	dsp.ti.com	Broadband	www.ti.com/broadband
Interface	interface.ti.com	Digital Control	www.ti.com/digitalcontrol
Logic	logic.ti.com	Military	www.ti.com/military
Power Mgmt	power.ti.com	Optical Networking	www.ti.com/opticalnetwork
Microcontrollers	microcontroller.ti.com	Security	www.ti.com/security
		Telephony	www.ti.com/telephony
		Video & Imaging	www.ti.com/video
		Wireless	www.ti.com/wireless

Mailing Address: Texas Instruments
Post Office Box 655303 Dallas, Texas 75265

Contents

<i>Section</i>	<i>Title</i>	<i>Page</i>
1	Introduction	1-1
1.1	Features	1-2
1.2	Functional Block Diagram	1-3
1.3	Terminal Assignments	1-4
1.4	Ordering Information	1-5
1.5	Terminal Functions	1-6
2	Specifications	2-1
2.1	Absolute Maximum Ratings Over Operating Free-Air Temperature Range	2-1
2.2	Recommended Operating Conditions	2-1
2.3	Electrical Characteristics Over Recommended Operating Conditions	2-2
2.3.1	DAC	2-2
2.3.2	Analog Line Input to Line Output	2-2
2.3.3	Stereo Headphone Output	2-3
2.3.4	Analog Reference Levels	2-3
2.3.5	Digital I/O	2-3
2.3.6	Supply Current	2-3
2.4	Digital-Interface Timing	2-4
2.4.1	Audio Interface (Master Mode)	2-4
2.4.2	Audio Interface (Slave-Mode)	2-5
2.4.3	Three-Wire Control Interface (SDI)	2-6
2.4.4	Two-Wire Control Interface	2-6
3	How to Use the DAC23	3-1
3.1	Control Interfaces	3-1
3.1.1	SPI	3-1
3.1.2	2-Wire	3-1
3.1.3	Register Map	3-2
3.2	Analog Interface	3-4
3.2.1	Line Inputs	3-4
3.2.2	Line Outputs	3-5
3.2.3	Headphone Output	3-5
3.3	Digital Audio Interface	3-5
3.3.1	Digital Audio-Interface Modes	3-5
3.3.2	Audio Sampling Rates	3-7
3.3.3	Digital Filter Characteristics	3-10
A	Mechanical Data	A-1

List of Illustrations

<i>Figure</i>	<i>Title</i>	<i>Page</i>
2-1	System-Clock Timing Requirements	2-4
2-2	Master-Mode Timing Requirements	2-4
2-3	Slave-Mode Timing Requirements	2-5
2-4	Three-Wire Control Interface Timing Requirements	2-6
2-5	Two-Wire Control Interface Timing Requirements	2-6
3-1	SPI Timing	3-1
3-2	2-Wire Compatible Timing	3-2
3-3	Analog Line Input Circuit	3-5
3-4	Right Justified Mode Timing	3-6
3-5	Left Justified Mode Timing	3-6
3-6	I2S Mode Timing	3-6
3-7	DSP Mode Timing	3-7
3-8	Digital De-Emphasis Filter Response – 44.1 kHz Sampling	3-10
3-9	Digital De-Emphasis Filter Response – 48 kHz Sampling	3-11
3-10	DAC Digital Filter Response 0: USB Mode	3-11
3-11	DAC Digital Filter Ripple 0: USB Mode	3-11
3-12	DAC Digital Filter Response 1: USB Mode Only	3-12
3-13	DAC Digital Filter Ripple 1: USB Mode Only	3-12
3-14	DAC Digital Filter Response 2: USB Mode and Normal Modes	3-12
3-15	DAC Digital Filter Ripple 2: USB Mode and Normal Modes	3-13
3-16	DAC Digital Filter Response 3: USB Mode Only	3-13
3-17	DAC Digital Filter Ripple 3: USB Mode Only	3-13

1 Introduction

The TLV320DAC23 is a high performance stereo DAC with highly integrated analog functionality. The DACs within the TLV320DAC23 are comprised of multibit sigma-delta technology with integrated over-sampling digital interpolation filters. Supported data transfer word lengths are 16, 20, 24, and 32 bits with sample rates from 8 kHz to 96 kHz. The DAC sigma-delta modulator features a second order multibit architecture with up to 100 dBA SNR at audio sample rates up to 96 kHz. This enables high quality digital audio playback capability while consuming less than 19 mW during playback only. The TLV320DAC23 is the ideal choice for portable digital audio player applications such as MP3 digital audio players.

Integrated analog features consist of stereo line inputs with an analog bypass path and a stereo headphone amplifier with analog volume control and mute. The headphone amplifier is capable of delivering 30 mW per channel into 32 Ω . The analog bypass path allows use of the stereo line inputs and the headphone amplifier with analog volume control while completely bypassing the DAC, thus enabling further design flexibility such as integrated FM tuners.

While the TLV320DAC23 supports the industry standard over-sample rates of 256 f_s and 384 f_s , unique over-sample rates of 250 f_s and 272 f_s are provided which optimize interface considerations in designs using TI C54x DSPs and USB data interfaces. A single 12-MHz crystal can be used to supply clocking to the DSP, USB, and DAC. The TLV320DAC23 features an internal oscillator which, when connected to a 12-MHz external crystal, will provide a system clock to the DSP and other peripherals at either 12 MHz or 6 MHz using an internal clock buffer and selectable divider. Audio sample rates of 48 kHz and CD standard rates of 44.1 kHz are directly supported from a 12-MHz master clock with 250 f_s and 272 f_s over-sample rates.

Low power consumption and flexible power management allow selective shutdown of DAC functions, thus extending battery life in portable applications. Couple this design solution with the industry's smallest package, the TI proprietary MicroStar Junior™ using only 25 mm² of board area, powerful portable stereo audio designs are easily realizable in a cost effective, space saving total analog solution.

1.1 Features

- High-Performance Stereo DAC
 - 100-dB SNR multibit sigma-delta ADC (A-weighted at 48 kHz)
 - 1.42 V – 3.6 V digital supply: compatible with TI C54x DSP core voltages
 - 2.7 V – 3.6 V analog supply: compatible TI C54x DSP buffer voltages
 - 8-kHz – 96-kHz sampling-frequency support
- Software control via TI McBSP-compatible multiprotocol serial port
 - 2-wire-compatible and SPI-compatible serial port protocols
 - Glueless interface to TI McBSPs
- Audio data input/output via TI McBSP compatible programmable audio interface
 - I²S-compatible interface
 - Standard I²S, MSB, or LSB justified data transfers
 - 16/20/24/32-bit word lengths
 - Audio master/slave timing capability optimized for TI DSPs (250/272 f_s)
 - Industry-standard master/slave support also provided (256/384 f_s)
 - Glueless interface to TI McBSPs
- Stereo line inputs
- Stereo line outputs
 - Analog stereo mixer for DAC and analog bypass path
- Analog volume control with mute
- Highly efficient linear headphone amplifier
 - 30 mW into 32 Ω from a 3.3-V analog supply voltage
- Flexible power management under total software control
 - 18-mW power consumption during playback mode
 - Standby power consumption <150 μW
 - Power-down power consumption <15 μW
- Industry's smallest package: 32-Pin TI proprietary MicroStar Junior
 - 25 mm² total board area
 - 28-Pin TSSOP available (62 mm² total board area)
 - 28-Pin QFN available (25 mm² total board area)
- Ideally suitable for portable solid-state audio players and recorders

1.2 Functional Block Diagram

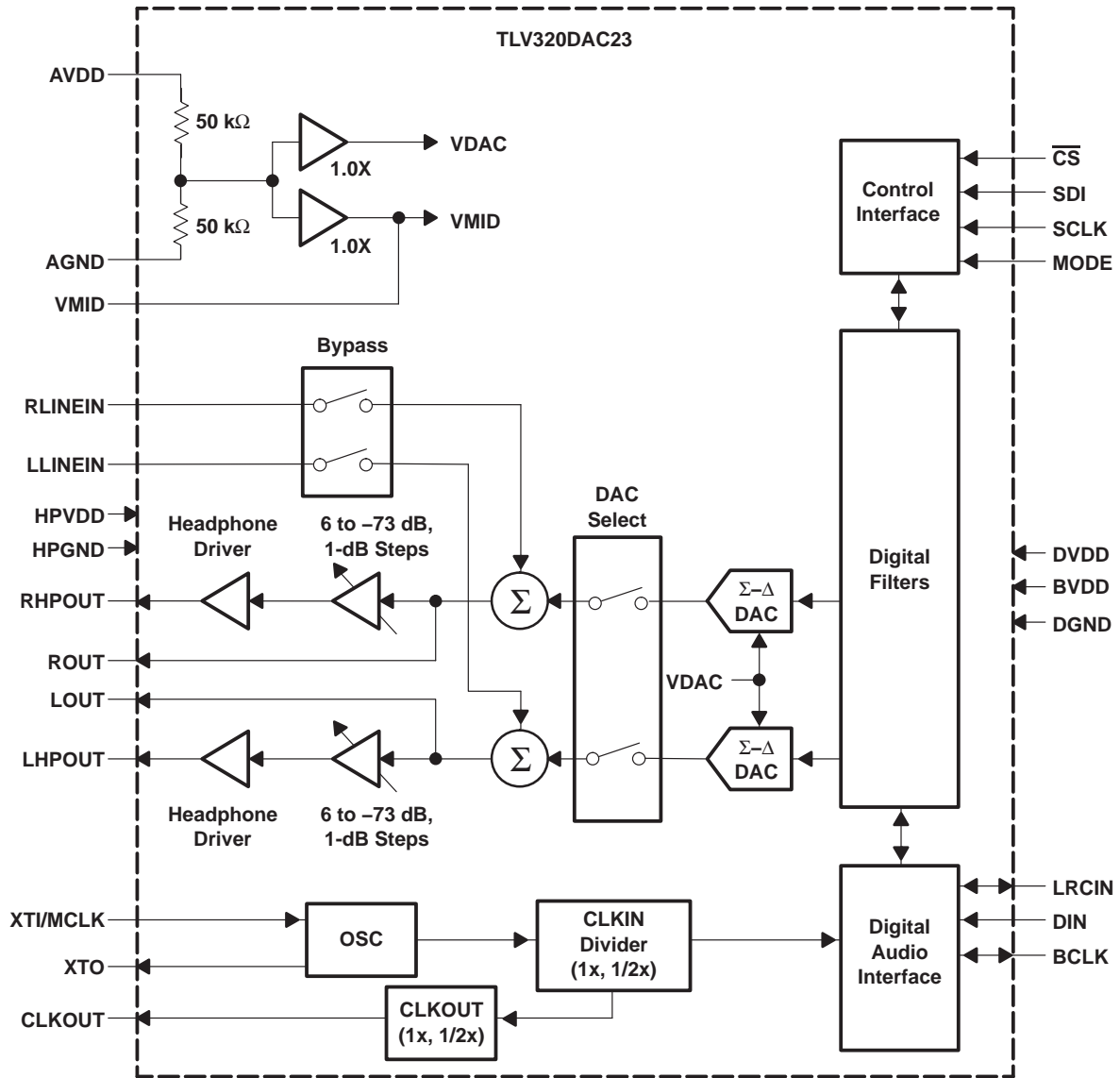

1.3 Terminal Assignments

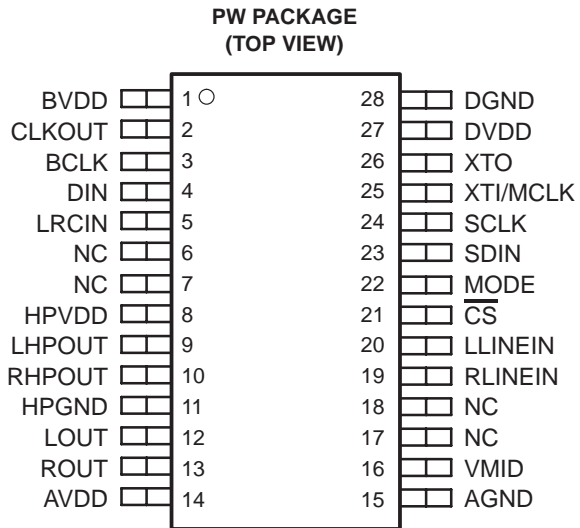
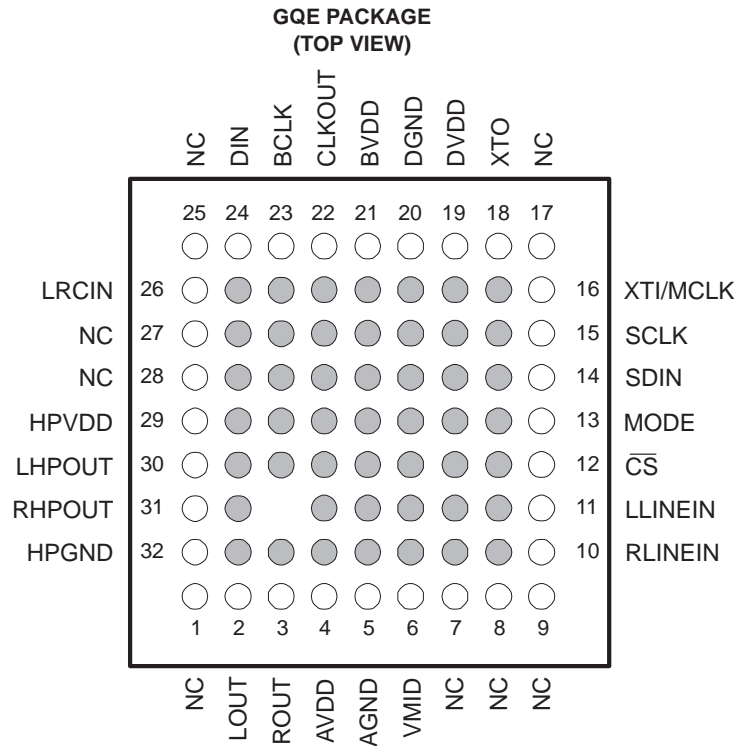

NC – No internal connection

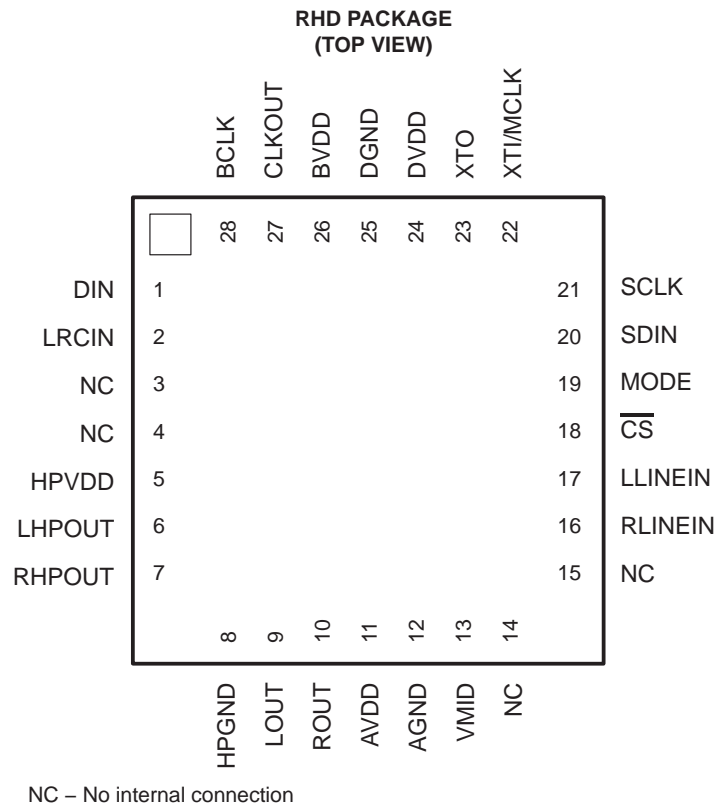

1.4 Ordering Information

T _A	PACKAGE		
	32-Pin MicroStar Junior GQE	28-Pin TSSOP PW	28-Pin QFN RHD
-10°C to 70°C	TLV320DAC23GQE	TLV320DAC23PW	TLV320DAC23RHD
-40°C to 85°C	TLV320DAC23IGQE	TLV320DAC23IPW	TLV320DAC23IRHD

1.5 Terminal Functions

TERMINAL				I/O	DESCRIPTION
NAME	NUMBER				
	GQE	PW	RHD		
AGND	5	15	12	–	Analog supply return
AVDD	4	14	11	–	Analog supply input. Voltage level is 3.3 V nominal.
BCLK	23	3	28	I/O	I ² S serial-bit clock. In audio master mode, the DAC23 generates this signal and sends it to the DSP. In audio slave mode, the signal is generated by the DSP.
BVDD	21	1	26	–	Buffer supply input. Voltage range is from 2.7 V to 3.6 V.
CLKOUT	22	2	27	O	Clock output. This is a buffered version of the XTI input and is available in 1X or 1/2X frequencies of XTI. Frequency selection is controlled by bit X in control register XX.
$\overline{\text{CS}}$	12	21	18	I	Control port input latch/address select. For SPI control mode this input acts as the data latch control. For 2-wire control mode this input defines the seventh bit in the device address field. See Section 3.1 for details.
DIN	24	4	1	I	I ² S format serial data input to the sigma-delta stereo DAC
DGND	20	28	25	–	Digital supply return
DVDD	19	27	24	–	Digital supply input. Voltage range is 1.4 V to 3.6 V.
HPGND	32	11	8	–	Analog headphone amplifier supply return
HPVDD	29	8	5	–	Analog headphone amplifier supply input. Voltage level is 3.3 V nominal.
LHPOUT	30	9	6	O	Left stereo mixer-channel amplified headphone output. Nominal 0-dB output level is 1.0 V _{RMS} . Gain of –73 dB to 6 dB is provided in 1-dB steps.
LLINEIN	11	20	17	I	Left stereo-line input channel
LOUT	2	12	9	O	Left stereo mixer-channel line output. Nominal output level is 1.0 V _{RMS} .
LRCIN	26	5	2	I/O	I ² S DAC-word clock signal. In audio master mode, the DAC23 generates this framing signal and sends it to the DSP. In audio slave mode, the signal is generated by the DSP.
MODE	13	22	19	I	Serial interface mode input. See Section 3.1 for details.
NC	1, 7, 8, 9, 17, 25, 27, 28	6, 7, 17, 18	3, 4, 14, 15	–	Not Used—No internal connection
RHPOUT	31	10	7	O	Right stereo mixer-channel amplified headphone output. Nominal 0-dB output level is 1.0 V _{RMS} . Gain of –73 dB to 6 dB is provided in 1-dB steps.
RLINEIN	10	19	16	I	Right stereo-line input channel
ROUT	3	13	10	O	Right stereo mixer-channel line output. Nominal output level is 1.0 V _{RMS} .
SCLK	15	24	21	I	Control port serial data clock. For both SPI and 2-wire control modes this is the serial clock input. See Section 3.1 for details.
SDIN	14	23	20	I	Control port serial data input. For both SPI and 2-wire control modes this is the serial data input and also is used to select the control protocol after reset. See Section 3.1 for details.
VMID	6	16	13	I	Midrail voltage decoupling input. 10- μ F and 0.1- μ F capacitors should be connected in parallel to this terminal for noise filtering. Voltage level is 1/2 AVDD nominal.
XTI/MCLK	16	25	22	I	Crystal or external clock input. Used for derivation of all internal clocks on the DAC23.
XTO	18	26	23	O	Crystal output. Connect to external crystal for applications where the DAC23 is the audio timing master. Not used in applications where external clock source is used.

2.3 Electrical Characteristics Over Recommended Operating Conditions, AV_{DD} , HPV_{DD} , $BV_{DD} = 3.3$ V, $DV_{DD} = 1.5$ V, Master Mode, $XTI = 12$ MHz, (unless otherwise stated)

2.3.1 DAC

2.3.1.1 Load = 10 k Ω , 50 pF

PARAMETER	TEST CONDITIONS	MIN	TYP	MAX	UNIT
0-dB full-scale output voltage			1.0		V_{RMS}
Signal-to-noise ratio, A-weighted, 0-dB gain (see Notes 3, 4, and 5)	$AV_{DD} = 3.3$ V	$f_s = 44.1$ kHz	90	100	dB
		$f_s = 96$ kHz		98	
	$AV_{DD} = 2.7$ V	$f_s = 44.1$ kHz		93	
Dynamic range, A-weighted (see Note 5)	$AV_{DD} = 3.3$ V	85	90		dB
Total harmonic distortion (THD)	$AV_{DD} = 3.3$ V	1 kHz, 0 dB	-88	-80	dB
		1 kHz, -3 dB	-92		
	$AV_{DD} = 2.7$ V	1 kHz, 0 dB	-88	-80	dB
		1 kHz, -3 dB	-92		
Power supply rejection ratio	1 kHz, 100 mV $_{pp}$		50		dB
DAC channel separation			100		dB
THD+N	$AV_{DD}=3.3$ V, 1 kHz, 0dB		-84	-79	dB

2.3.2 Analog Line Input to Line Output

2.3.2.1 Load = 10 k Ω , 50 pF, no gain on input

PARAMETER	TEST CONDITIONS	MIN	TYP	MAX	UNIT
0-dB full-scale output voltage			1.0		V_{RMS}
Signal-to-noise ratio, (SNR) A-weighted, 0-dB gain (see Notes 3, 5)	$AV_{DD} = 3.3$ V	90	95		dB
Total harmonic distortion (THD)	$AV_{DD} = 3.3$ V	1 kHz, 0 dB	-86	-80	dB
		1 kHz, -3 dB	-92	-86	
	$AV_{DD} = 2.7$ V	1 kHz, 0 dB	-86		dB
		1 kHz, -3 dB	-92		
Power supply rejection ratio	1 kHz, 100 mV $_{pp}$		50		dB
Mute attenuation	1 kHz, 0 dB		80		dB
Input resistance		10 k	24 k		Ω

2.3.3 Stereo Headphone Output

PARAMETER	TEST CONDITIONS	MIN	TYP	MAX	UNIT
0-dB full-scale output voltage			1.0		V _{RMS}
Maximum output power, P _O	R _L = 32 Ω		30		mW
	R _L = 16 Ω		40		
Signal-to-noise ratio, A-weighted (see Note 4)	AV _{DD} = 3.3 V	90	97		dB
Total harmonic distortion	AV _{DD} = 3.3 V, 1 kHz output, into 32Ω	P _O = 10 mW		-60	dB
		P _O = 20 mW		-40	
Power supply rejection ratio	1 kHz, 100 mV _{pp}		50		dB
Programmable gain	1 kHz output	-73		6	dB
Programmable-gain step size			1		dB
Mute attenuation	1 kHz output		80		dB

- NOTES:
- Ratio of output level with 1-kHz full-scale input, to the output level with the input short circuited, measured A-weighted over a 20-Hz to 20-kHz bandwidth using an audio analyzer.
 - All performance measurements done with 20-kHz low-pass filter and, where noted, A-weighted filter. Failure to use such a filter results in higher THD + N and lower SNR and dynamic range readings than shown in the electrical characteristics. The low-pass filter removes out-of-band noise, which, although not audible, may affect dynamic specification values.
 - Ratio of output level with 1-kHz full-scale input, to the output level with all zeros into the digital input, measured A-weighted over a 20-Hz to 20-kHz bandwidth.

2.3.4 Analog Reference Levels

PARAMETER	MIN	TYP	MAX	UNIT
Reference voltage, V _{MID}	AV _{DD} /2 - 50 mV		AV _{DD} /2 + 50 mV	V
Divider resistance, R _{VMID}	40	50	60	kΩ

2.3.5 Digital I/O

PARAMETER	MIN	TYP	MAX	UNIT
V _{IL} Input low level			0.3 × BV _{DD}	V
V _{IH} Input high level	0.7 × BV _{DD}			V
V _{OL} Output low level			0.1 × BV _{DD}	V
V _{OH} Output high level	0.9 × BV _{DD}			V

2.3.6 Supply Current

PARAMETER	MIN	TYP	MAX	UNIT	
I _{TOT} Total supply current, no input signal (3.3 V supply)	Line playback only (Clk power off, 50 Ω)	6	8	mA	
	Line playback only (Clk power on, 50 Ω)		15		
	Analog bypass (line in to line out)		3		
	Power down	Oscillator enabled	1.5		
		Oscillator disabled	0.01		0.025

2.4 Digital-Interface Timing

PARAMETER		MIN	TYP	MAX	UNIT
$t_{w(1)}$	System-clock pulse duration, MCLK/XTI	High	18		ns
$t_{w(2)}$		Low	18		
$t_c(1)$	System-clock period, MCLK/XTI	54			ns
	Duty cycle, MCLK/XTI	40/60%	60/40%		
$t_{pd(1)}$	Propagation delay, CLKOUT	0		10	ns

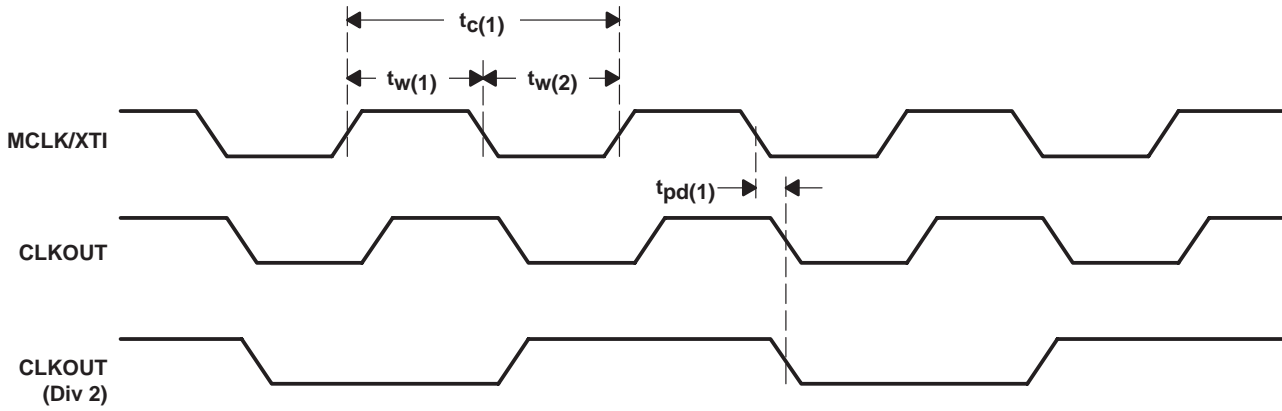

Figure 2-1. System-Clock Timing Requirements

2.4.1 Audio Interface (Master Mode)

PARAMETER		MIN	TYP	MAX	UNIT
$t_{pd(2)}$	Propagation delay, LRCIN	0		10	ns
$t_{su(1)}$	Setup time, DIN	10			ns
$t_h(1)$	Hold time, DIN	10			ns

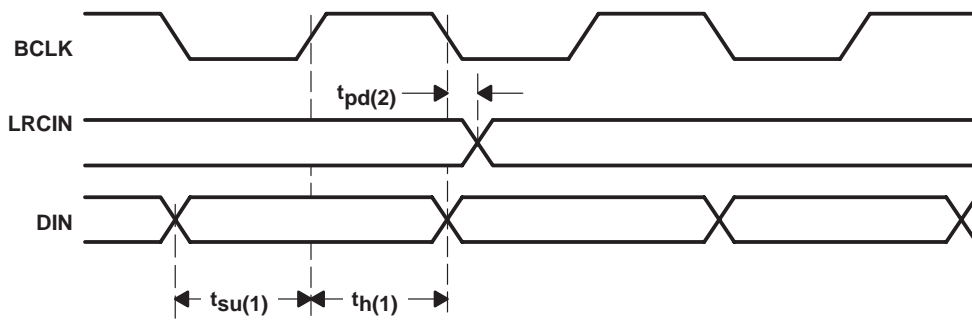

Figure 2-2. Master-Mode Timing Requirements

2.4.2 Audio Interface (Slave-Mode)

PARAMETER			MIN	TYP	MAX	UNIT
$t_{w(3)}$	Pulse duration, BCLK	High	20			ns
$t_{w(4)}$		Low	20			
$t_{c(2)}$	Clock period, BCLK		50			ns
$t_{su(2)}$	Setup time, DIN		10			ns
$t_{h(2)}$	Hold time, DIN		10			ns
$t_{su(3)}$	Setup time, LRCIN		10			ns
$t_{h(3)}$	Hold time, LRCIN		10			ns

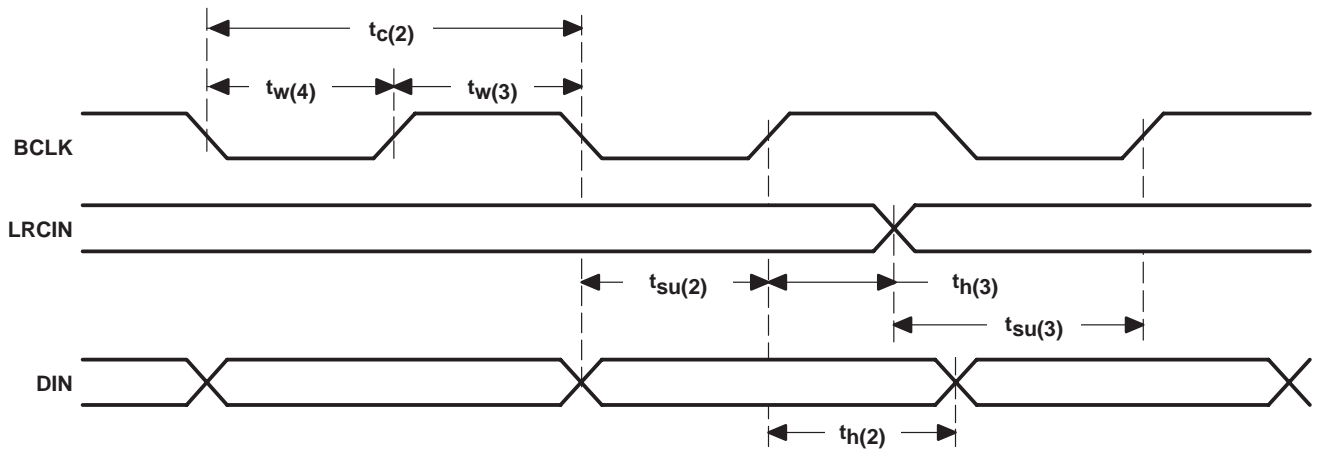

Figure 2–3. Slave-Mode Timing Requirements

2.4.3 Three-Wire Control Interface (SDI)

PARAMETER			MIN	TYP	MAX	UNIT
$t_{w(5)}$	Clock pulse duration, SCLK	High	20			ns
$t_{w(6)}$		Low	20			
$t_{c(3)}$	Clock period, SCLK		80			ns
$t_{su(4)}$	Clock rising edge to \overline{CS} rising edge, SCLK		60			ns
$t_{su(5)}$	Setup time, SDIN to SCLK		20			ns
$t_{h(4)}$	Hold time, SCLK to SDIN		20			ns
$t_{w(7)}$	Pulse duration, \overline{CS}	High	20			ns
$t_{w(8)}$		Low	20			

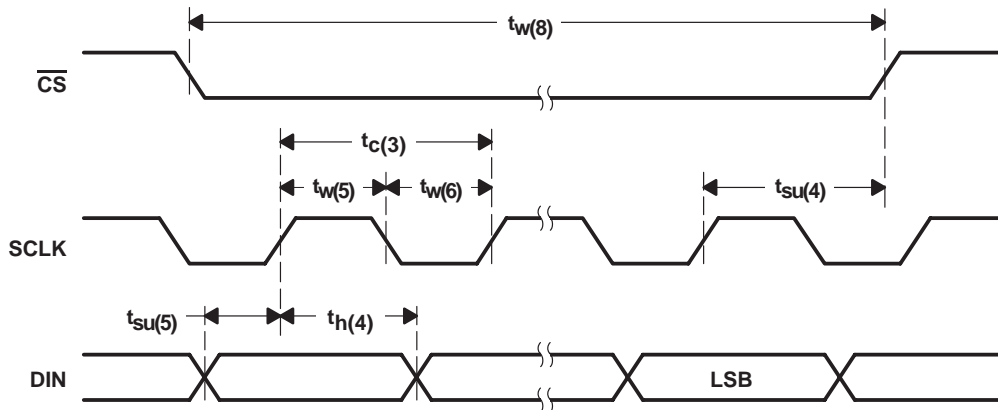

Figure 2-4. Three-Wire Control Interface Timing Requirements

2.4.4 Two-Wire Control Interface

PARAMETER			MIN	TYP	MAX	UNIT
$t_{w(9)}$	Clock pulse duration, SCLK	High	1.3			μ s
$t_{w(10)}$		Low	600			ns
$f(sf)$	Clock frequency, SCLK		0	400		kHz
$t_{h(5)}$	Hold time (start condition)		600			ns
$t_{su(6)}$	Setup time (start condition)		600			ns
$t_{h(6)}$	Data hold time				900	ns
$t_{su(7)}$	Data setup time		100			ns
t_r	Rise time, SDIN, SCLK				300	ns
t_f	Fall time, SDIN, SCLK				300	ns
$t_{su(8)}$	Setup time (stop condition)		600			ns

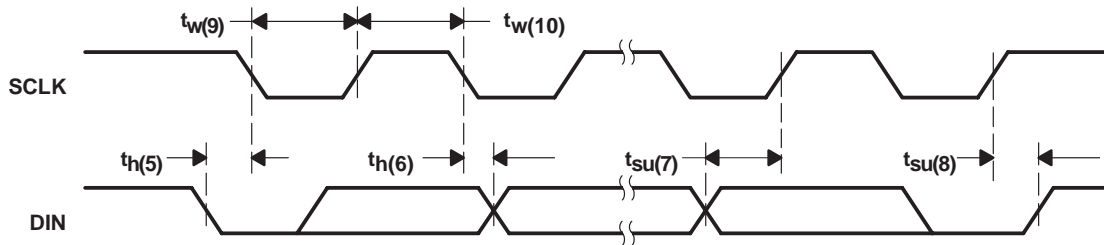

Figure 2-5. Two-Wire Control Interface Timing Requirements

3 How to Use the DAC23

3.1 Control Interfaces

The TLV320DAC23 has many programmable features. The control interface is used to program the registers of the device. The control interface complies with SPI (three-wire operation) and two-wire operation specifications. The state of the MODE terminal selects the control interface type. The MODE pin must be hardwired to the required level.

MODE	INTERFACE
0	2-wire
1	SPI

3.1.1 SPI

In SPI mode, SDI carries the serial data, SCLK is the serial clock and \overline{CS} latches the data word into the TLV320DAC23. The interface is compatible with microcontrollers and DSPs with an SPI interface.

A control word consists of 16 bits, starting with the MSB. The data bits are latched on the rising edge of SCLK. A rising edge on \overline{CS} after the sixteenth rising clock edge latches the data word into the DAC (see Figure 3-1).

The control word is divided into two parts. The first part is the address block, the second part is the data block:

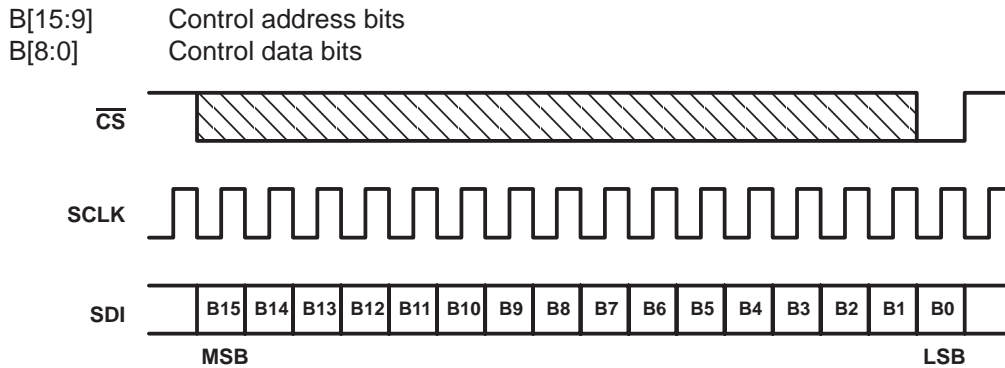

Figure 3–1. SPI Timing

3.1.2 2-Wire

In 2-wire mode, the data transfer uses SDI for the serial data and SCLK for the serial clock. The start condition is a falling edge on SDIN while SCLK is high. The seven bits following the start condition determine the device on the 2-wire bus that receives the data. R/W determines the direction of the data transfer. The TLV320DAC23 is a write only device and responds only if R/W is 0. The device operates only as a slave device whose address is selected by setting the state of the CS pin as follows.

\overline{CS} STATE (Default = 0)	ADDRESS
0	0011010
1	0011011

The device that recognizes the address responds by pulling SDI low during the ninth clock cycle, acknowledging the data transfer. The control follows in the next two eight-bit blocks. The stop condition after the data transfer is a rising edge on SDI when SCLK is high (see Figure 3-2).

The 16-bit control word is divided into two parts. The first part is the address block, the second part is the data block:

B[15:9] Control address bits
 B[8:0] Control data bits

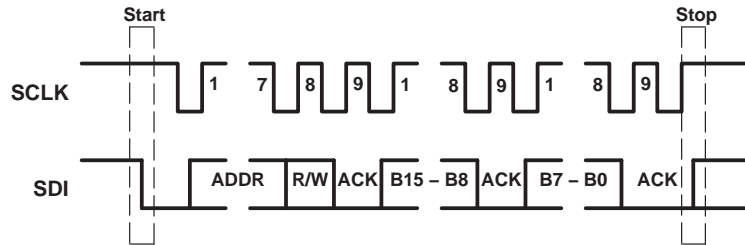

Figure 3–2. 2-Wire Compatible Timing

3.1.3 Register Map

The TLV320DAC23 has the following set of registers, which are used to program the modes of operation.

ADDRESS	REGISTER
0000000	Left line input channel control
0000001	Right line input channel control
0000010	Left channel headphone volume control
0000011	Right channel headphone volume control
0000100	Analog audio path control
0000101	Digital audio path control
0000110	Power down control
0000111	Digital audio interface format
0001000	Sample rate control
0001001	Digital interface activation
0001111	Reset register

Left Line Input Channel Control (Address: 0000000)

BIT	D8	D7	D6	D5	D4	D3	D2	D1	D0
Function	LRS	LIM	X	X	X	X	X	X	X
Default	0	1	0	0	0	0	0	0	0

LRS Left/right line simultaneous volume/mute update
 Simultaneous update 0 = Disabled 1 = Enabled
 LIM Left line input mute 0 = Normal 1 = Muted
 X Reserved

Right Line Input Channel Control (Address: 0000001)

BIT	D8	D7	D6	D5	D4	D3	D2	D1	D0
Function	RLS	RIM	X	X	X	X	X	X	X
Default	0	1	0	0	0	0	0	0	0

RLS Right/left line simultaneous volume/mute update
 Simultaneous update 0 = Disabled 1 = Enabled
 RIM Right line input mute 0 = Normal 1 = Muted
 X Reserved

Left Channel Headphone Volume Control (Address: 0000010)

BIT	D8	D7	D6	D5	D4	D3	D2	D1	D0
Function	LRS	LZC	LHV6	LHV5	LHV4	LHV3	LHV2	LHV1	LHV0
Default	0	1	1	1	1	1	0	0	1

LRS Left/right headphone channel simultaneous volume/mute update
 Simultaneous update 0 = Disabled 1 = Enabled

LZC Left-channel zero-cross detect
 Zero-cross detect 0 = Off 1 = On

LHV[6:0] Left Headphone volume control (1111001 = 0 dB default)
 1111111 = +6 dB, 79 steps between +6 dB and -73 dB (mute), 0110000 = -73 dB (mute),
 any thing below 0110000 does nothing – you are still muted

Right Channel Headphone Volume Control (Address: 0000011)

BIT	D8	D7	D6	D5	D4	D3	D2	D1	D0
Function	RLS	RZC	RHV6	RHV5	RHV4	RHV3	RHV2	RHV1	RHV0
Default	0	1	1	1	1	1	0	0	1

RLS Right/left headphone channel simultaneous volume/mute Update
 Simultaneous update 0 = Disabled 1 = Enabled

RZC Right-channel zero-cross detect
 Zero-cross detect 0 = Off 1 = On

RHV[6:0] Right headphone volume control (1111001 = 0 dB default)
 1111111 = +6 dB, 79 steps between +6 dB and -73 dB (mute), 0110000 = -73 dB (mute),
 any thing below 0110000 does nothing – you are still muted

Analog Audio Path Control (Address: 0000100)

BIT	D8	D7	D6	D5	D4	D3	D2	D1	D0
Function	X	X	X	X	DAC	BYP	X	X	X
Default	0	0	0	0	0	1	0	1	0

DAC DAC select 0 = DAC off 1 = DAC selected

BYP Bypass 0 = Disabled 1 = Enabled

X Reserved

Digital Audio Path Control (Address: 0000101)

BIT	D8	D7	D6	D5	D4	D3	D2	D1	D0
Function	X	X	X	X	X	DACM	DEEMP1	DEEMP0	X
Default	0	0	0	0	0	1	0	0	0

DACM DAC soft mute 0 = Disabled 1 = Enabled

DEEMP[1:0] De-emphasis control 00 = Disabled 01 = 32 kHz 10 = 44.1 kHz 11 = 48 kHz

X Reserved

Power Down Control (Address: 0000110)

BIT	D8	D7	D6	D5	D4	D3	D2	D1	D0
Function	X	OFF	CLK	OSC	OUT	DAC	X	X	LINE
Default	0	0	0	1	1	1	1	1	1

OFF Power 0 = On 1 = Off

CLK Clock 0 = On 1 = Off

OSC Oscillator 0 = On 1 = Off

OUT Outputs 0 = On 1 = Off

DAC DAC 0 = On 1 = Off

LINE Line input 0 = On 1 = Off

X Reserved

Digital Audio Interface Format (Address: 0000111)

BIT	D8	D7	D6	D5	D4	D3	D2	D1	D0
Function	X	X	MS	LRSWAP	LRP	IWL1	IWL0	FOR1	FOR0
Default	0	0	0	0	0	0	0	0	1

MS Master/slave mode 0 = Slave 1 = Master
 LRSWAP DAC left/right swap 0 = Disabled 1 = Enabled
 LRP DAC left/right phase 0 = Right channel on, LRCIN high
 1 = Right channel on, LRCIN low
 IWL[1:0] Input bit length 00 = 16 bit 01 = 20 bit 10 = 24 bit 11 = 32 bit
 FOR[1:0] Data format 11 = DSP format, frame sync followed by two data words
 10 = I²S format, MSB first, left – 1 aligned
 01 = MSB first, left aligned
 00 = MSB first, right aligned

X Reserved

- NOTES: 1. In Master mode, the TLV320AIC23 supplies the BCLK and LRCIN. In Slave mode, BCLK and LRCIN are supplied to the TLV320AIC23.
 2. In normal mode, BCLK = MCLK/4 for all sample rates except for 88.2 kHz and 96 kHz. For 88.2 kHz and 96 kHz sample rate, BCLK = MCLK.
 3. In USB mode, bit BCLK = MCLK

Sample Rate Control (Address: 0001000)

BIT	D8	D7	D6	D5	D4	D3	D2	D1	D0
Function	X	CLKOUT	CLKIN	SR3	SR2	SR1	SR0	BOSR	USB/Normal
Default	0	0	0	0	0	0	0	0	0

CLKOUT Clock output divider 0 = MCLK 1 = MCLK/2
 CLKIN Clock input divider 0 = MCLK 1 = MCLK/2
 SR[3:0] Sampling rate control (see Sections 3.3.2.1 AND 3.3.2.2)
 BOSR Base oversampling rate
 USB mode: 0 = 250 f_S 1 = 272 f_S
 Normal mode: 0 = 256 f_S 1 = 384 f_S
 USB/Normal Clock mode select: 0 = Normal 1 = USB
 X Reserved

Digital Interface Activation (Address: 0001001)

BIT	D8	D7	D6	D5	D4	D3	D2	D1	D0
Function	X	X	X	X	X	X	X	X	ACT
Default	0	0	0	0	0	0	0	0	0

ACT Activate interface 0 = Inactive 1 = Active
 X Reserved

Reset Register (Address: 0001111)

BIT	D8	D7	D6	D5	D4	D3	D2	D1	D0
Function	RES	RES	RES	RES	RES	RES	RES	RES	RES
Default	0	0	0	0	0	0	0	0	0

RES Write to this register triggers reset

3.2 Analog Interface

3.2.1 Line Inputs

The TLV320DAC23 has line inputs for the left and the right audio channels (RLINEIN and LLINEIN). Both line inputs have independently programmable mutes. Active and passive filters for the two channels prevent high frequencies from folding back into the audio band.

The line inputs are biased internally to VMID. When the line inputs are muted or the device is set to standby mode, the line inputs are kept biased to VMID using special antithump circuitry. This reduces audible clicks that otherwise might be heard when reactivating the inputs.

For interfacing to a CD system, the line input should be scaled to 1 V_{RMS} to avoid clipping, using the circuit shown in Figure 3-3.

Where:

- R1 = 5 kΩ
- R2 = 5 kΩ
- C1 = 47 pF
- C2 = 470 nF

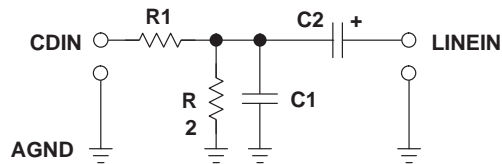

Figure 3–3. Analog Line Input Circuit

R1 and R2 divide the input signal by two, reducing the 2 V_{RMS} from the CD player to the nominal 1 V_{RMS} of the DAC23 inputs. C1 filters high-frequency noise, and C2 removes any dc component from the signal.

3.2.2 Line Outputs

The TLV320DAC23 has two low-impedance line outputs (LLINEOUT and RLINEOUT) capable of driving line loads with 10-kΩ and 50-pF impedances.

The DAC full-scale output voltage is 1.0 V_{RMS} at AV_{DD} = 3.3 V. The full-scale range tracks linearly with the analog supply voltage AV_{DD}. The DAC is connected to the line outputs via a low-pass filter that removes out-of-band components. No further external filtering is required in most applications.

The DAC outputs and the line inputs are summed into the line outputs. The line outputs are muted by either muting the DAC (analog) or soft muting (digital) and disabling the bypass path (see Section 3.1.3).

3.2.3 Headphone Output

The TLV320DAC23 has stereo headphone outputs (LHPOUT and RHPOUT), and is designed to drive 16-Ω or 32-Ω headphones. The headphone output includes a high-quality volume control and mute function.

The headphone volume is logarithmically adjustable from 6 dB to –73 dB in 1-dB steps. Writing 000000 to the volume-control registers (see Section 3.1.3) mutes the headphone output. When the headphone output is muted or the device is placed in standby mode, the dc voltage is maintained at the outputs to prevent audible clicks.

A zero-cross detection circuit is provided under the control of the LZC and RZC bits. If this circuit is enabled, the volume-control values are updated only when the input signal to the gain stage is close to the analog ground level. This minimizes audible clicks as the volume is changed or the device is muted. This circuit has no time-out, so if only dc levels are being applied to the gain stage input of more than 20 mV, the gain is not updated.

The gain is independently programmable on the left and right channels. Both channels can be locked to the same value by setting the RLS and LRS bits (see Section 3.1.3).

3.3 Digital Audio Interface

3.3.1 Digital Audio-Interface Modes

The TLV320DAC23 supports four audio-interface modes.

- Right justified
- Left justified
- I²S mode
- DSP mode

The four modes are MSB first and operate with a variable word width between 16 to 32 bits (except right-justified mode, which does not support 32 bits).

The digital audio interface consists of clock signal BCLK, data signals DIN and and the synchronization signal LRCIN. BCLK is an output in master mode and an input in slave mode.

3.3.1.1 Right-Justified Mode

In right-justified mode, the LSB is available on the rising edge of BCLK, preceding a falling edge on LRCIN (see Figure 3-4).

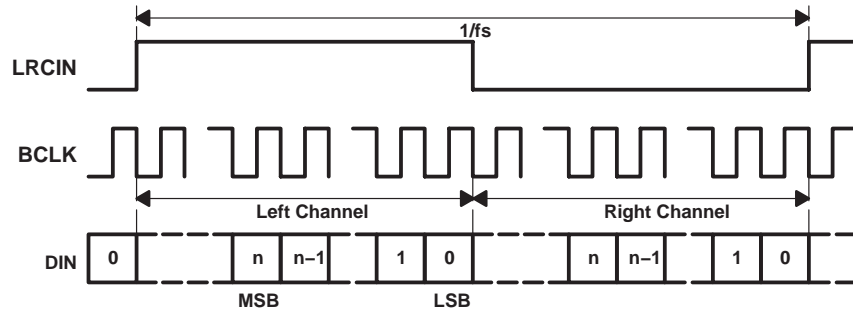

Figure 3-4. Right Justified Mode Timing

3.3.1.2 Left-Justified Mode

In left-justified mode, the MSB is available on the rising edge of BCLK, following a rising edge on LRCIN (see Figure 3-5)

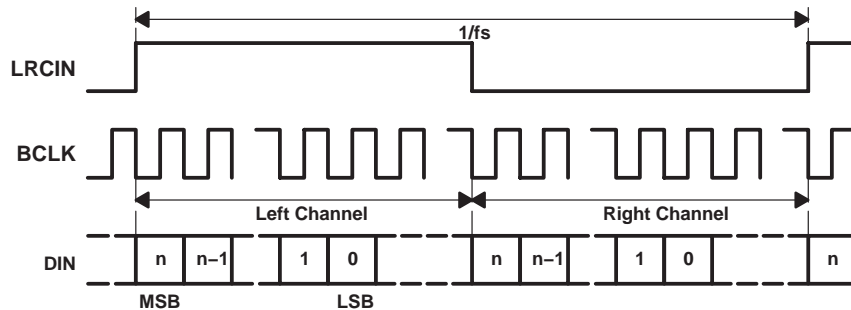

Figure 3-5. Left Justified Mode Timing

3.3.1.3 I²S Mode

In I²S mode, the MSB is available on the second rising edge of BCLK, after the falling edge on LRCIN (see Figure 3-6).

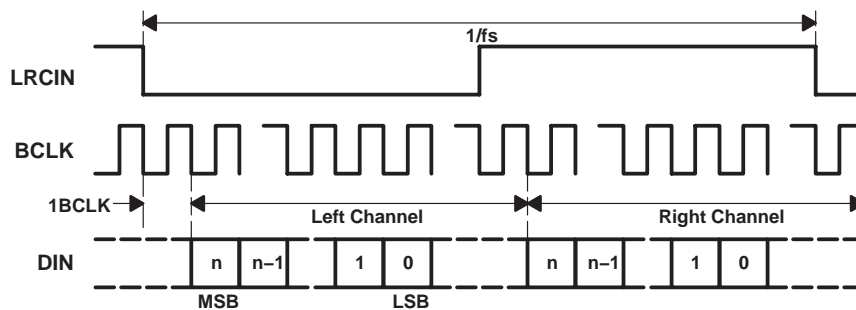

Figure 3-6. I²S Mode Timing

3.3.1.4 DSP Mode

The DSP mode is compatible with the McBSP ports of TI DSPs. LRCIN must be connected to the Frame Sync signal of the McBSP. A falling edge on LRCIN starts the data transfer. The left-channel data consists of the first data word, which is immediately followed by the right channel data word (see Figure 3-7).

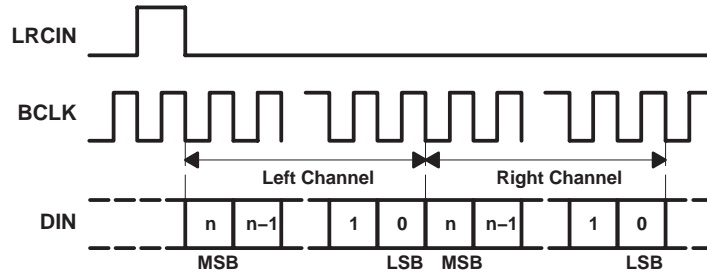

Figure 3–7. DSP Mode Timing

3.3.2 Audio Sampling Rates

The TLV320DAC23 can operate in master or slave clock mode. In the master mode, the TLV320DAC23 clock and sampling rates are derived from a 12-MHz MCLK signal. This 12-MHz clock signal is compatible with the USB specification. The TLV320DAC23 can be used directly in a USB system.

In the slave mode, the TLV320DAC23 clock and sample rates are controlled by using an appropriate MCLK or crystal frequency and the sample rate control register settings.

The settings in the sample rate control register control the clock mode and sampling rates.

Sample Rate Control (Address: 0001000)

BIT	D8	D7	D6	D5	D4	D3	D2	D1	D0
Function	X	CLKOUT	CLKIN	SR3	SR2	SR1	SR0	BOSR	USB/Normal
Default	0	0	0	0	0	0	0	0	0

CLKOUT	Clock output divider	0 = MCLK	1 = MCLK/2
CLKIN	Clock input divider	0 = MCLK	1 = MCLK/2
SR[3:0]	Sample rate control (see Sections 3.3.2.1 and 3.3.2.2)		
BOSR	Base oversampling rate		
	USB mode:	0 = 250 f_s	1 = 272 f_s
	Normal mode:	0 = 256 f_s	1 = 384 f_s
USB/Normal	Clock mode select:	0 =Normal	1 =USB
X	Reserved		

The clock circuit of the DAC23 has two internal dividers. The first, controlled by CLKIN, applies to the sampling-rate generator of the DAC. The second, controlled by CLKOUT, applies only to the CLKOUT terminal. By setting CLKIN to 1, the entire DAC is clocked with half the frequency, effectively dividing the resulting sampling rates by two.

3.3.2.1 USB-Mode Sampling Rates

In the USB mode, the following DAC sampling rates are available:
(MCLK = 12 MHz)

SAMPLING RATE kHz	FILTER TYPE	SAMPLING-RATE CONTROL SETTINGS					
		SR3	SR2	SR1	SR0	BOSR	CLKIN
96	3	0	1	1	1	0	0
88.235	2	1	1	1	1	1	0
48	0	0	0	0	0	0	0
44.118	1	1	0	0	0	1	0
32	0	0	1	1	0	0	0
8.021	1	1	0	1	1	1	0
8	0	0	0	1	1	0	0
48	3	0	1	1	1	0	1
44.118	2	1	1	1	1	1	1
24	0	0	0	0	0	0	1
22.059	1	1	0	0	0	1	1
16	0	0	1	1	0	0	1
4.0105	1	1	0	1	1	1	1
4	0	0	0	1	1	0	1

(MCLK = 6 MHz)

SAMPLING RATE kHz	FILTER TYPE	SAMPLING-RATE CONTROL SETTINGS					
		SR3	SR2	SR1	SR0	BOSR	CLKIN
48	3	0	1	1	1	0	0
44.118	2	1	1	1	1	1	0
24	0	0	0	0	0	0	0
22.059	1	1	0	0	0	1	0
16	0	0	1	1	0	0	0
4.0105	1	1	0	1	1	1	0
4	0	0	0	1	1	0	0
24	3	0	1	1	1	0	1
22.059	2	1	1	1	1	1	1
12	0	0	0	0	0	0	1
11.029	1	1	0	0	0	1	1
8	0	0	1	1	0	0	1
2.005	1	1	0	1	1	1	1
2	0	0	0	1	1	0	1

3.3.2.2 Normal-Mode Sampling Rates

In Normal mode, the following DAC sampling rates, depending on the MCLK frequency, are available:

MCLK = 12.288 MHz

SAMPLING RATE	FILTER TYPE	SAMPLING-RATE CONTROL SETTINGS					
kHz		SR3	SR2	SR1	SR0	BOSR	CLKIN
96	2	0	1	1	1	0	0
48	1	0	0	0	0	0	0
32	1	0	1	1	0	0	0
8	1	0	0	1	1	0	0
48	2	0	1	1	1	0	1
24	1	0	0	0	0	0	1
16	1	0	1	1	0	0	1
4	1	0	0	1	1	0	1

MCLK = 11.2896 MHz

SAMPLING RATE	FILTER TYPE	SAMPLING-RATE CONTROL SETTINGS					
kHz		SR3	SR2	SR1	SR0	BOSR	CLKIN
88.2	2	1	1	1	1	0	0
44.1	1	1	0	0	0	0	0
8.021	1	1	0	1	1	0	0
44.1	2	1	1	1	1	0	1
22.05	1	1	0	0	0	0	1
4.0105	1	1	0	1	0	0	1

MCLK = 18.432 MHz

SAMPLING RATE	FILTER TYPE	SAMPLING-RATE CONTROL SETTINGS					
kHz		SR3	SR2	SR1	SR0	BOSR	CLKIN
96	2	0	1	1	1	1	0
48	1	0	0	0	0	1	0
32	1	0	1	1	0	1	0
8	1	0	0	1	1	1	0
48	2	0	1	1	1	1	1
24	1	0	0	0	0	1	1
16	1	0	1	1	0	1	1
4	1	0	0	1	1	1	1

MCLK = 16.9344 MHz

SAMPLING RATE	FILTER TYPE	SAMPLING-RATE CONTROL SETTINGS					
kHz		SR3	SR2	SR1	SR0	BOSR	CLKIN
88.2	2	1	1	1	1	1	0
44.1	1	1	0	0	0	1	0
8.021	1	1	0	1	1	1	0
44.1	2	1	1	1	1	1	1
22.05	1	1	0	0	0	1	1
4.0105	1	1	0	1	1	1	1

3.3.3 Digital Filter Characteristics

PARAMETER	TEST CONDITIONS	MIN	TYP	MAX	UNIT
DAC Filter Characteristics (48-kHz Sampling Rate)					
Passband	± 0.03 dB	$0.416 f_s$			Hz
Stopband	-6 dB		$0.5 f_s$		Hz
Passband ripple				± 0.03	dB
Stopband attenuation	$f > 0.584 f_s$		-50		dB
DAC Filter Characteristics (44.1-kHz Sampling Rate)					
Passband	± 0.03 dB	$0.4535 f_s$			Hz
Stopband	-6 dB		$0.5 f_s$		Hz
Passband ripple				± 0.03	dB
Stopband attenuation	$f > 0.5465 f_s$		-50		dB

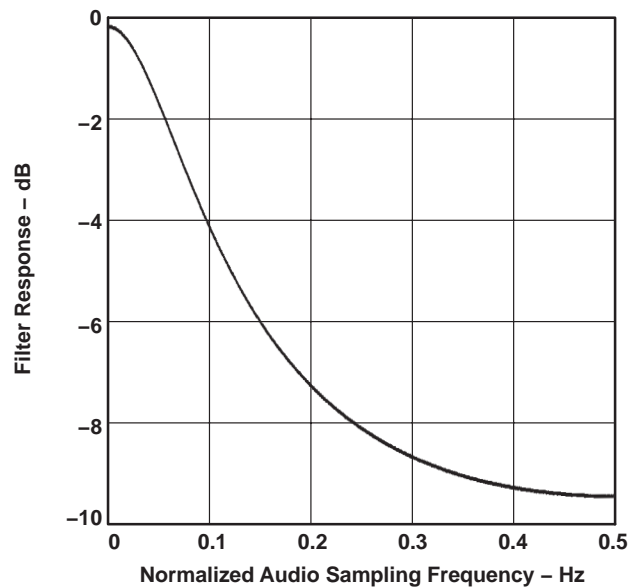

Figure 3–8. Digital De-Emphasis Filter Response – 44.1 kHz Sampling

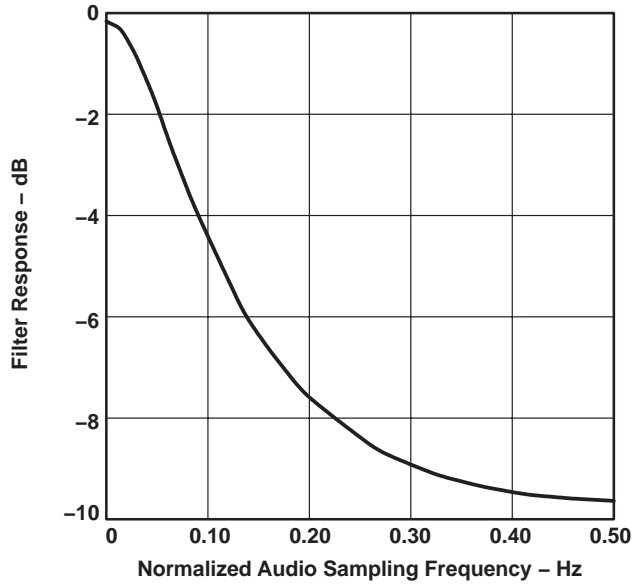

Figure 3-9. Digital De-Emphasis Filter Response - 48 kHz Sampling

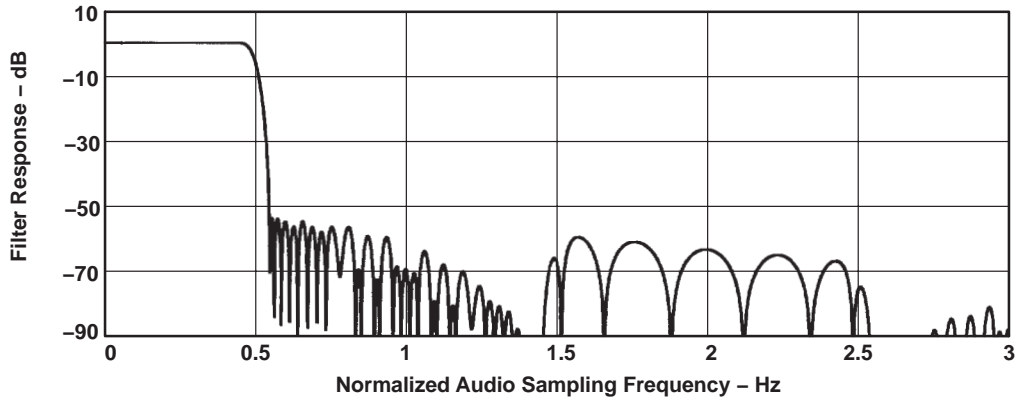

Figure 3-10. DAC Digital Filter Response 0: USB Mode

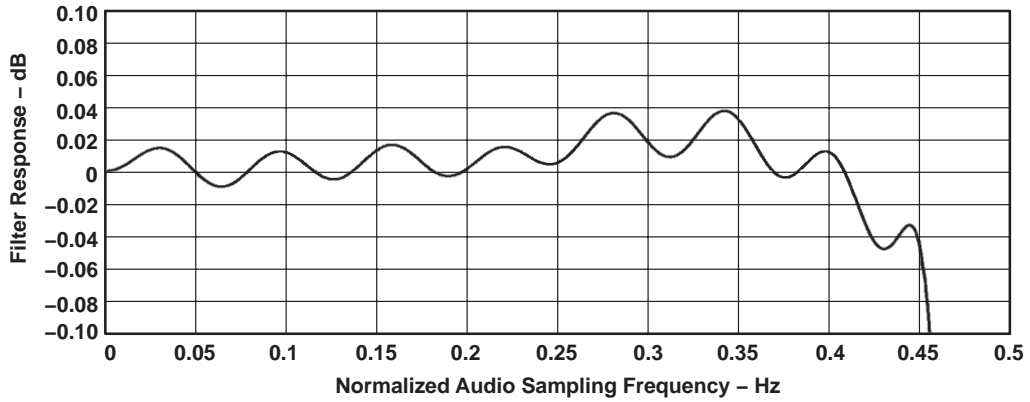

Figure 3-11. DAC Digital Filter Ripple 0: USB Mode

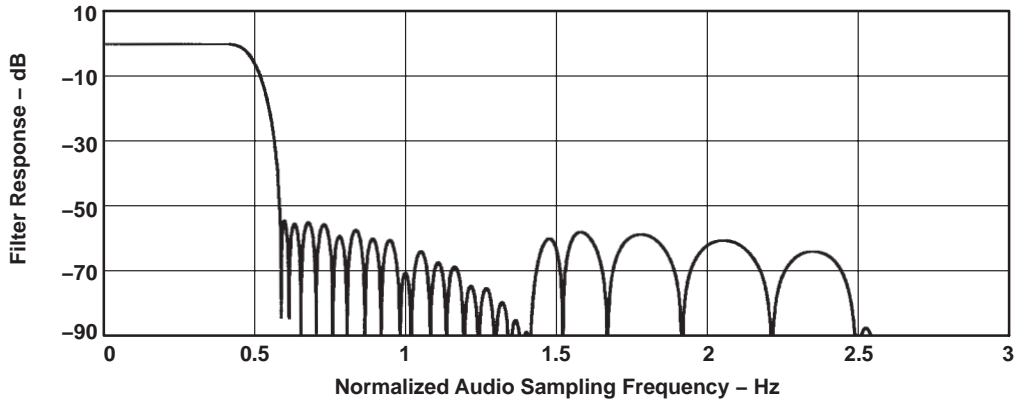

Figure 3-12. DAC Digital Filter Response 1: USB Mode Only

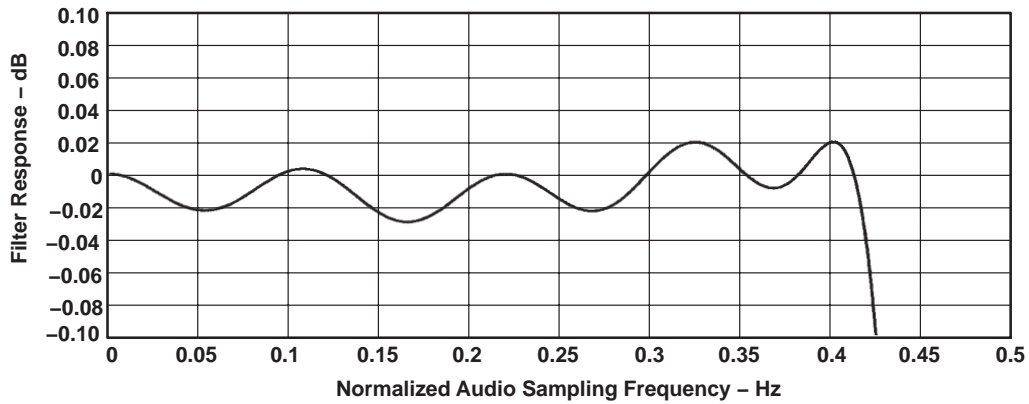

Figure 3-13. DAC Digital Filter Ripple 1: USB Mode Only

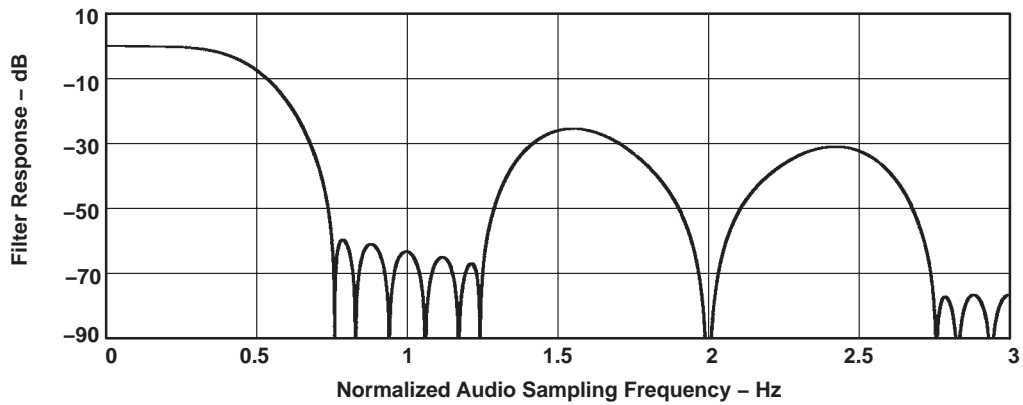

Figure 3-14. DAC Digital Filter Response 2: USB Mode and Normal Modes

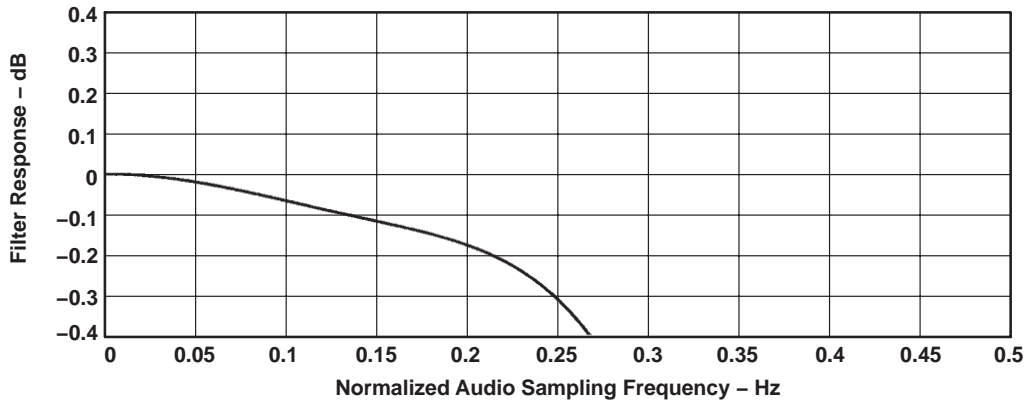

Figure 3-15. DAC Digital Filter Ripple 2: USB Mode and Normal Modes

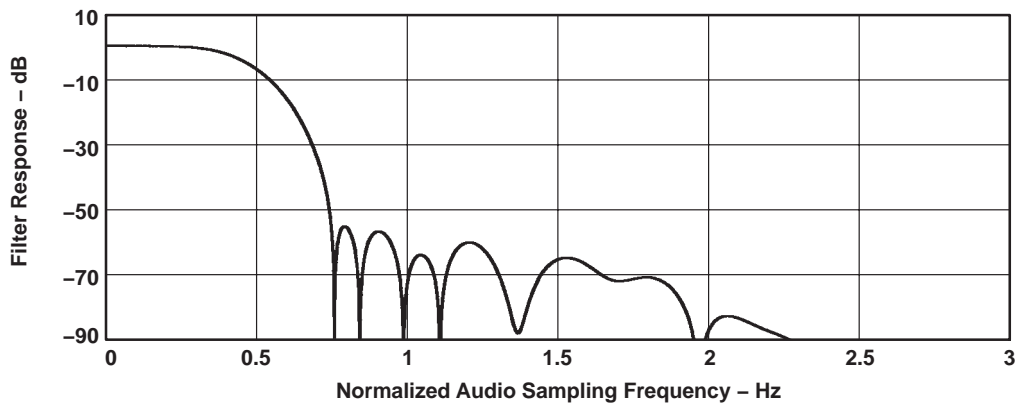

Figure 3-16. DAC Digital Filter Response 3: USB Mode Only

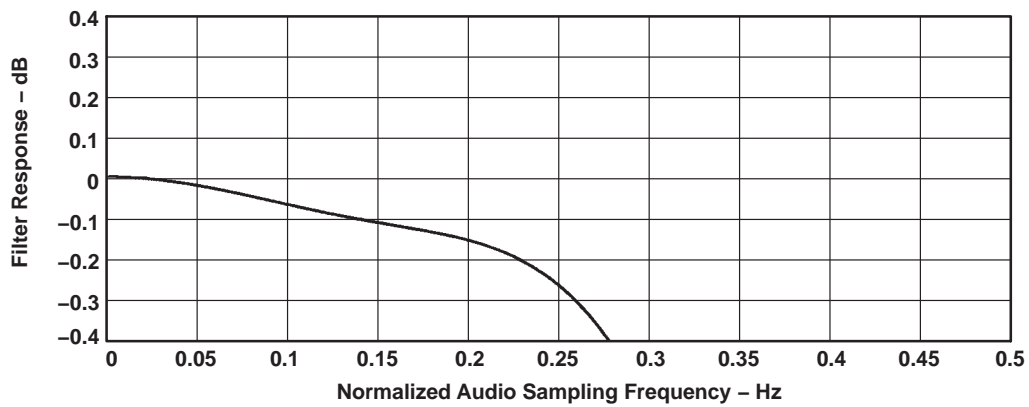
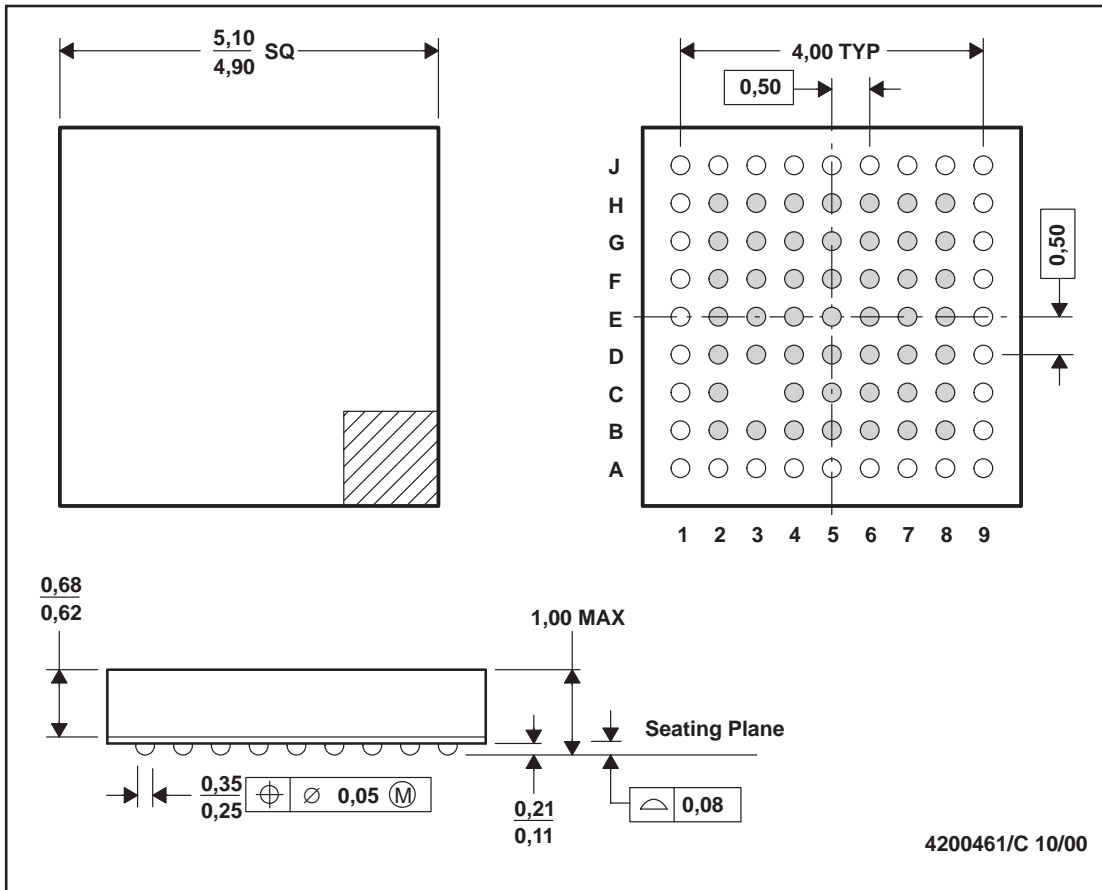

Figure 3-17. DAC Digital Filter Ripple 3: USB Mode Only

Appendix A Mechanical Data

GQE (S-PBGA-N80)

PLASTIC BALL GRID ARRAY



- NOTES:
- A. All linear dimensions are in millimeters.
 - B. This drawing is subject to change without notice.
 - C. MicroStar Junior™ BGA configuration
 - D. Falls within JEDEC MO-225

MicroStar Junior is a trademark of Texas Instruments.

PW (R-PDSO-G**)

PLASTIC SMALL-OUTLINE PACKAGE

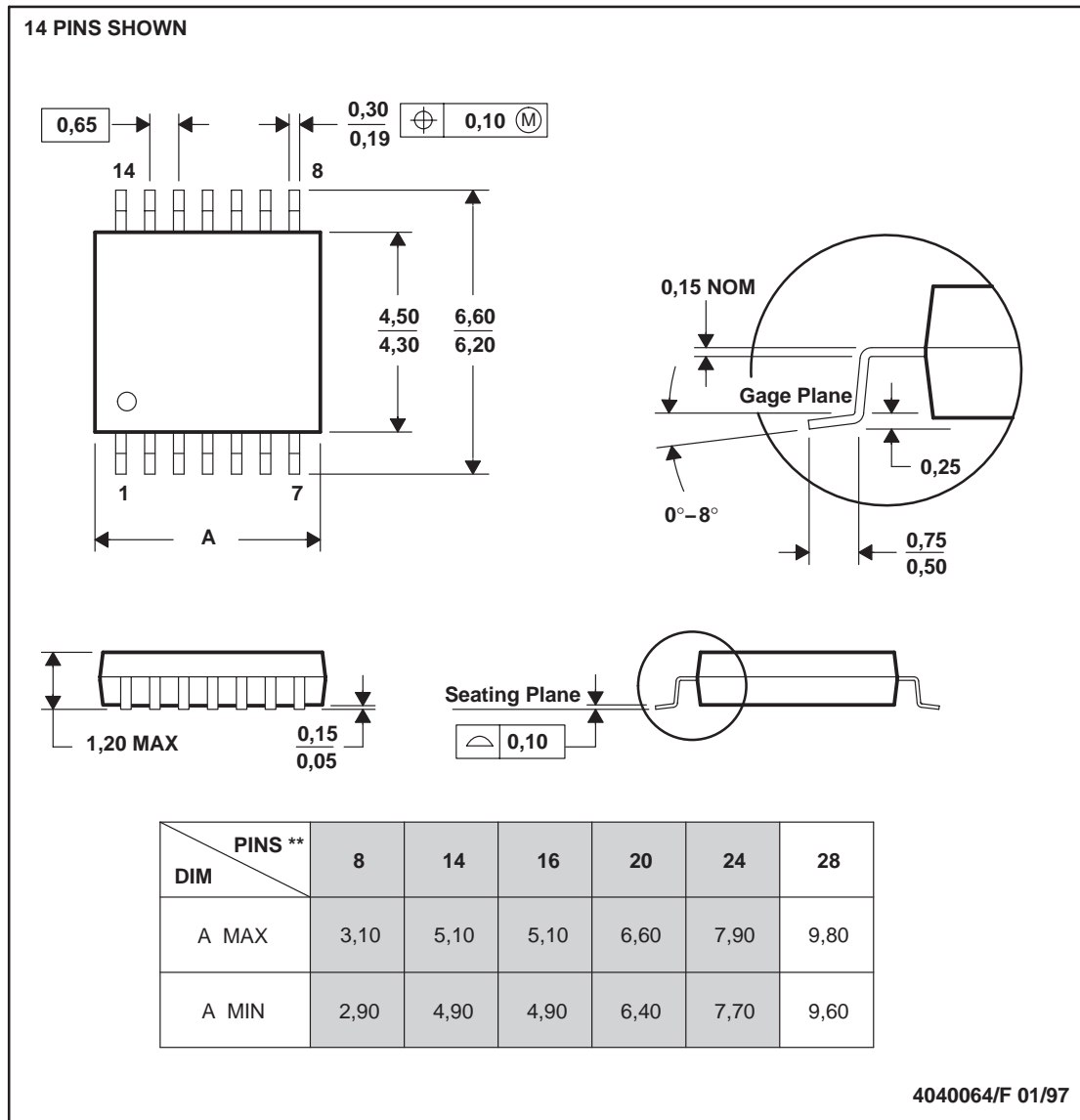

- NOTES: A. All linear dimensions are in millimeters.
 B. This drawing is subject to change without notice.
 C. Body dimensions do not include mold flash or protrusion not to exceed 0,15.
 D. Falls within JEDEC MO-153

RHD (S-PQFP-N28)

PLASTIC QUAD FLATPACK

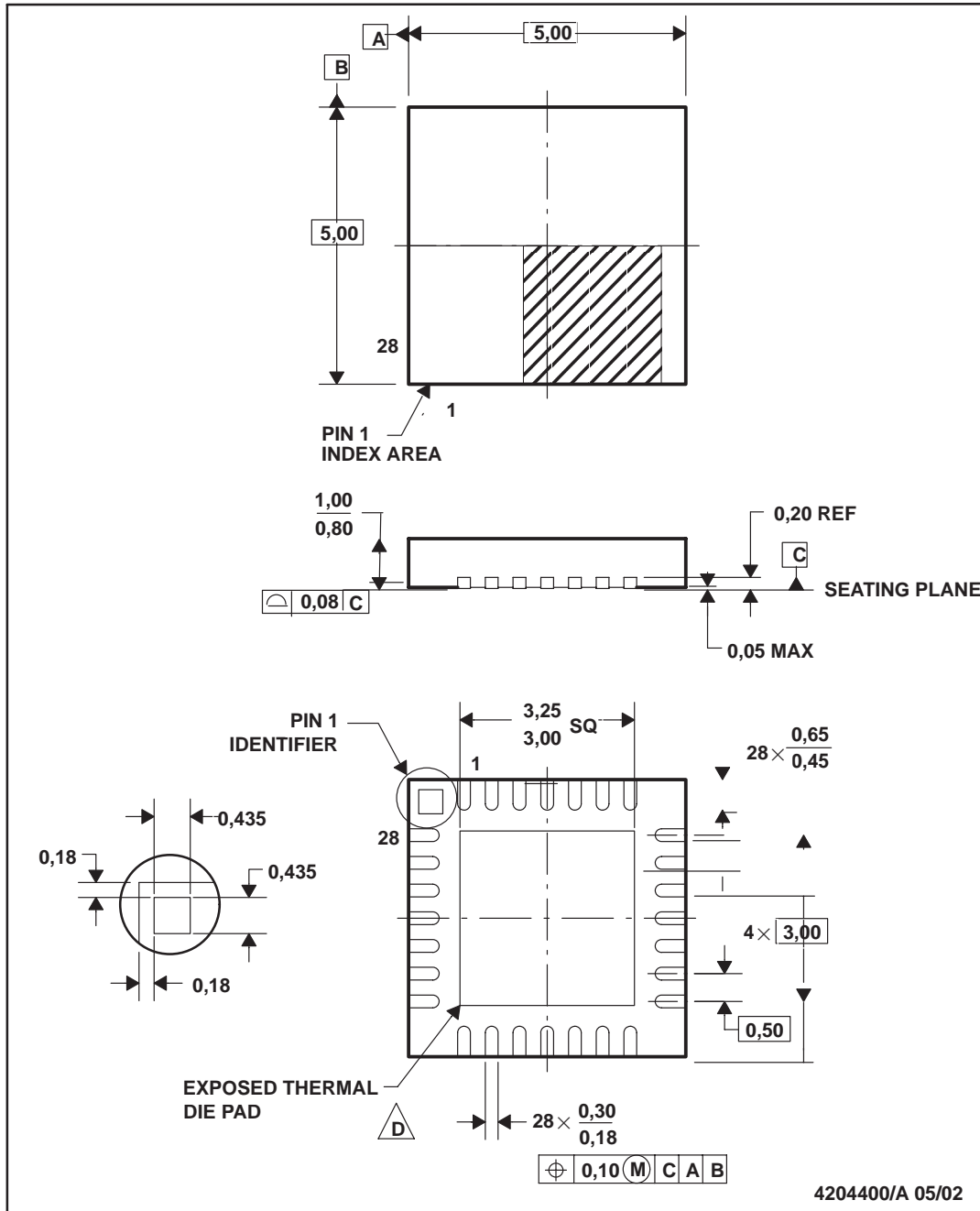

- NOTES: A. All linear dimensions are in millimeters.
 B. This drawing is subject to change without notice.
 C. QFN (Quad Flatpack No-Lead) Package configuration.

- D. The Package thermal performance may be enhanced by bonding the thermal die pad to an external thermal plane. This pad is electrically and thermally connected to the backside of the die and possibly selected ground leads.
- E. Package complies to JEDEC MO-220.

Looking for pricing, stock, or lifecycle information?

Click below to explore more details on WIN SOURCE:

 [View TLV320DAC23IGQER on WIN SOURCE](#)

 [Texas Instruments](#) Information

Optimize Your Supply Chain with WIN SOURCE Solutions

-  Global Sourcing Solution
-  Obsolete Management
-  Cost Control Management
-  Shortage Management
-  Alternative Solution
-  Excess Inventory Management