



**THE DATASHEET OF
TLVH431DQDBVR,125**



TLVH431 family

Low voltage adjustable precision shunt regulators

Rev. 1 — 27 April 2012

Product data sheet

1. General description

Low voltage three-terminal shunt regulator family with an output voltage range between V_{ref} (1.24 V) and 18 V, to be set by two external resistors.

Table 1. Product overview

Reference voltage tolerance (V_{ref})	Package	Temperature range (T_{amb})			Pinning configuration (see Table 5)
		0 °C to 70 °C	-40 °C to 85 °C	-40 °C to 125 °C	
1.5 %	SOT23	TLVH431CDBZR	TLVH431IDBZR	TLVH431QDBZR	normal pinning
		-	-	TLVH431MQDBZR	mirrored pinning
	SOT753	-	-	TLVH431QDBVR	-
1 %	SOT23	TLVH431ACDBZR	TLVH431AIDBZR	TLVH431AQDBZR	normal pinning
		-	-	TLVH431AMQDBZR	mirrored pinning
	SOT753	-	-	TLVH431AQDBVR	-
0.75 %	SOT23	-	-	TLVH431DQDBZR	normal pinning
		-	-	TLVH431DMQDBZR	mirrored pinning
	SOT753	-	-	TLVH431DQDBVR	-

2. Features and benefits

- Programmable output voltage up to 18 V
- Three different reference voltage tolerances:
 - ◆ Standard grade: 1.5 %
 - ◆ A-Grade: 1 %
 - ◆ D-Grade: 0.75 %
- Typical temperature drift: 4 mV (in a range of -40 °C up to 125 °C)
- Low output noise
- Typical output impedance: 0.1 Ω
- Sink current capability: 0.08 mA to 70 mA
- AEC-Q100 qualified (grade 1)

3. Applications

- Shunt regulator
- Precision current limiter
- Precision constant current sink
- Isolated feedback loop for Switch Mode Power Supply (SMPS)



4. Quick reference data

Table 2. Quick reference data

Symbol	Parameter	Conditions	Min	Typ	Max	Unit
V_{KA}	cathode-anode voltage		V_{ref}	-	18	V
I_K	cathode current		0.08	-	70	mA
V_{ref}	reference voltage	$V_{KA} = V_{ref}$; $I_K = 10$ mA; $T_{amb} = 25$ °C				
	Standard-Grade (1.5 %)		1222	1240	1258	mV
	A-Grade (1 %)		1228	1240	1252	mV
	D-Grade (0.75 %)		1231	1240	1249	mV

5. Ordering information

Table 3. Ordering information

Type number	Package		Version
	Name	Description	
TLVH431CDBZR	TO-236AB	plastic surface-mounted package; 3 leads	SOT23
TLVH431IDBZR			
TLVH431QDBZR			
TLVH431MQDBZR			
TLVH431ACDBZR			
TLVH431AIDBZR			
TLVH431AQDBZR			
TLVH431AMQDBZR			
TLVH431DQDBZR			
TLVH431DMQDBZR			
TLVH431QDBVR	SC-74A	plastic surface-mounted package; 5 leads	SOT753
TLVH431AQDBVR			
TLVH431DQDBVR			

6. Marking

Table 4. Marking codes

Type number	Marking code ^[1]	Type number	Marking code ^[1]
TLVH431CDBZR	NM*	TLVH431AMQDBZR	NX*
TLVH431IDBZR	NN*	TLVH431DQDBZR	*SE
TLVH431QDBZR	NP*	TLVH431DMQDBZR	*SF
TLVH431MQDBZR	NW*	TLVH431QDBVR	AB3
TLVH431ACDBZR	NQ*	TLVH431AQDBVR	AB6
TLVH431AIDBZR	NR*	TLVH431DQDBVR	AC1
TLVH431AQDBZR	NS*	-	-

[1] * = placeholder for manufacturing site code.

7. Functional diagram

The TLVH431 family comprises a range of 3-terminal adjustable shunt regulators, with specified thermal stability over applicable automotive and commercial temperature ranges. The output voltage can be set to any value between V_{ref} (approximately 1.24 V) and 18 V with two external resistors (see [Figure 10](#)). These devices have a typical output impedance of 0.1 Ω . Active output circuitry provides a very sharp turn-on characteristic, making these devices excellent replacements for Zener diodes in many applications like on-board regulation, adjustable power supplies and switching power supplies.

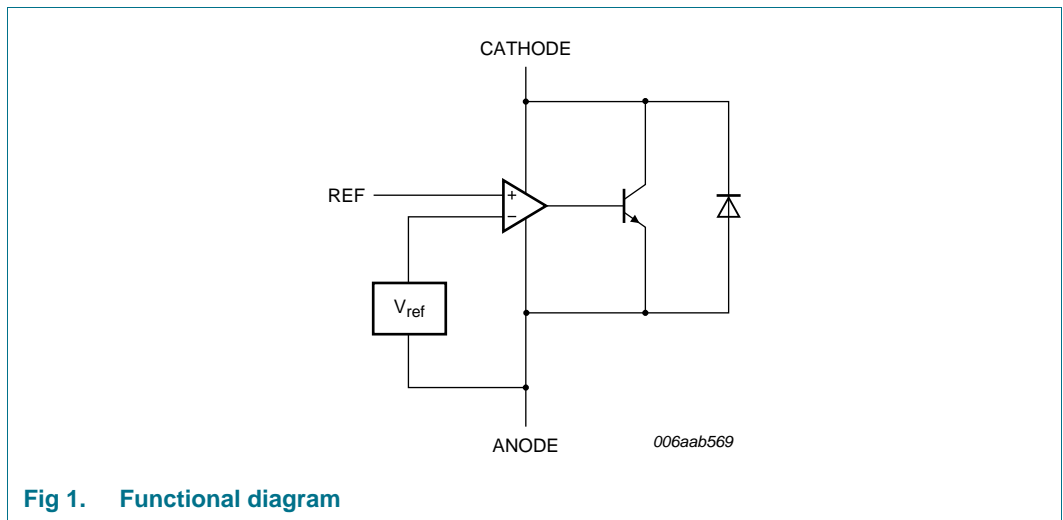

Fig 1. Functional diagram

8. Pinning information

Table 5. Pinning

Pin	Symbol	Description	Simplified outline	Graphic symbol
SOT23; normal pinning: All types without MQDBZR ending				
1	REF	reference		
2	k	cathode		
3	a	anode		
SOT23; mirrored pinning: All types with MQDBZR ending				
1	k	cathode		
2	REF	reference		
3	a	anode		

Table 5. Pinning ...continued

Pin	Symbol	Description	Simplified outline	Graphic symbol
SOT753				
1	n.c.	not connected	[1]	<p>006aab355</p>
2	n.c.	not connected	[1]	
3	k	cathode		
4	REF	reference		
5	a	anode		

[1] Pin 1 and 2 can be connected to anode for better thermal performance.

9. Limiting values

Table 6. Limiting values

In accordance with the Absolute Maximum Rating System (IEC 60134).

Symbol	Parameter	Conditions	Min	Max	Unit	
V_{KA}	cathode-anode voltage		-	20	V	
I_K	cathode current		-25	80	mA	
I_{ref}	reference current		-0.05	3	mA	
P_{tot}	total power dissipation	$T_{amb} \leq 25\text{ °C}$				
			SOT23	[1] -	390	mW
				[2] -	570	mW
				[3] -	800	mW
			SOT753	[1] -	310	mW
				[2] -	460	mW
			[3] -	700	mW	
T_j	junction temperature		-	150	°C	
T_{amb}	ambient temperature					
		TLVH431XCDBZR	0	+70	°C	
		TLVH431XIDBZR	-40	+85	°C	
		TLVH431XQDBZR TLVH431XQDBVR	-40	+125	°C	
T_{stg}	storage temperature		-65	+150	°C	

[1] Device mounted on an FR4 Printed-Circuit Board (PCB), single-sided copper, tin-plated and standard footprint.

[2] Device mounted on an FR4 PCB, single-sided copper, tin-plated, mounting pad for anode 1 cm².

[3] Device mounted on a ceramic PCB, Al₂O₃, standard footprint.

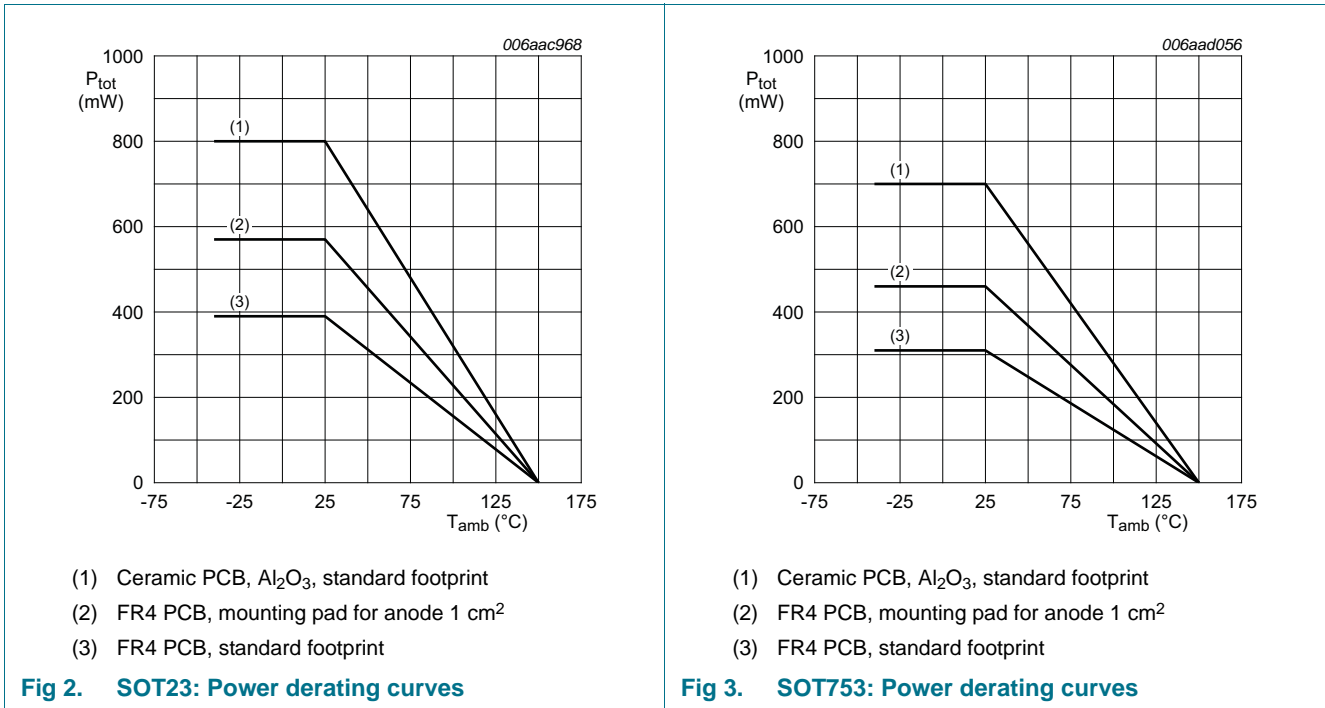

Table 7. ESD maximum ratings
T_{amb} = 25 °C unless otherwise specified.

Symbol	Parameter	Conditions	Min	Max	Unit
V _{ESD}	electrostatic discharge voltage	MIL-STD-883 (human body model)	-	4	kV
		machine model	-	400	V

10. Recommended operating conditions

Table 8. Operating conditions

Symbol	Parameter	Conditions	Min	Max	Unit
V _{KA}	cathode-anode voltage		V _{ref}	18	V
I _K	cathode current		0.08	70	mA

11. Thermal characteristics

Table 9. Thermal characteristics

Symbol	Parameter	Conditions	Min	Typ	Max	Unit			
$R_{th(j-a)}$	thermal resistance from junction to ambient	in free air							
			SOT23	[1]	-	-	320	K/W	
				[2]	-	-	220	K/W	
				[3]	-	-	155	K/W	
			SOT753	[1]	-	-	400	K/W	
				[2]	-	-	270	K/W	
				[3]	-	-	180	K/W	
			$R_{th(j-sp)}$	thermal resistance from junction to solder point	[4]				
					SOT23	-	-	35	K/W
SOT753	-	-			40	K/W			

[1] Device mounted on an FR4 PCB, single-sided copper, tin-plated and standard footprint.

[2] Device mounted on an FR4 PCB, single-sided copper, tin-plated, mounting pad for anode 1 cm².

[3] Device mounted on a ceramic PCB, Al₂O₃, standard footprint.

[4] Soldering point of anode.

12. Characteristics

Table 10. Characteristics

$T_{amb} = 25\text{ °C}$ unless otherwise specified.

Symbol	Parameter	Conditions	Min	Typ	Max	Unit
Standard-Grade (1.5 %): TLVH431CDBZR; TLVH431IDBZR; TLVH431QDBZR; TLVH431MQDBRZ; TLVH431QDBVR						
V_{ref}	reference voltage	$V_{KA} = V_{ref}; I_K = 10\text{ mA}$ $T_{amb} = 25\text{ °C}$	1222	1240	1258	mV
	TLVH431CDBZR	$T_{amb} = 0\text{ °C to }70\text{ °C}$	1210	-	1270	mV
	TLVH431IDBZR	$T_{amb} = -40\text{ °C to }85\text{ °C}$	1202	-	1278	mV
	TLVH431QDBZR TLVH431MQDBRZ TLVH431QDBVR	$T_{amb} = -40\text{ °C to }125\text{ °C}$	1194	-	1286	mV
	ΔV_{ref}	reference voltage variation	$V_{KA} = V_{ref}; I_K = 10\text{ mA}$			
	TLVH431CDBZR	$T_{amb} = 0\text{ °C to }70\text{ °C}$	-	2	10	mV
	TLVH431IDBZR	$T_{amb} = -40\text{ °C to }85\text{ °C}$	-	3	10	mV
	TLVH431QDBZR TLVH431MQDBRZ TLVH431QDBVR	$T_{amb} = -40\text{ °C to }125\text{ °C}$	-	4	10	mV
$\Delta V_{ref}/\Delta V_{KA}$	reference voltage variation to cathode-anode voltage variation ratio	$I_K = 10\text{ mA};$ $\Delta V_{KA} = V_{ref}\text{ to }18\text{ V}$	-	-0.5	-1.5	mV/V
I_{ref}	reference current	$I_K = 10\text{ mA};$ $R1 = 10\text{ k}\Omega; R2 = \text{open}$	-	0.19	0.30	μA
ΔI_{ref}	reference current variation	$I_K = 10\text{ mA};$ $R1 = 10\text{ k}\Omega; R2 = \text{open}$				
	TLVH431CDBZR	$T_{amb} = 0\text{ °C to }70\text{ °C}$	-	0.03	0.10	μA
	TLVH431IDBZR	$T_{amb} = -40\text{ °C to }85\text{ °C}$	-	0.06	0.16	μA
	TLVH431QDBZR TLVH431MQDBRZ TLVH431QDBVR	$T_{amb} = -40\text{ °C to }125\text{ °C}$	-	0.07	0.24	μA
	$I_{K(min)}$	minimum cathode current	$V_{KA} = V_{ref}$	-	55	80
I_{off}	off-state current	$V_{KA} = 18\text{ V}; V_{ref} = 0$	-	0.01	0.05	μA
Z_{KA}	dynamic cathode-anode impedance	$I_K = 0.1\text{ mA to }70\text{ mA};$ $V_{KA} = V_{ref}; f < 1\text{ kHz}$				
	SOT23		-	0.10	0.15	Ω
	SOT753		-	0.15	0.20	Ω

Table 10. Characteristics ...continued
 $T_{amb} = 25\text{ °C}$ unless otherwise specified.

Symbol	Parameter	Conditions	Min	Typ	Max	Unit
A-Grade (1 %): TLVH431ACDBZR; TLVH431AIDBZR; TLVH431AQDBZR; TLVH431AMQDBZR; TLVH431AQDBVR						
V_{ref}	reference voltage	$V_{KA} = V_{ref}; I_K = 10\text{ mA}$ $T_{amb} = 25\text{ °C}$	1228	1240	1252	mV
		TLVH431ACDBZR $T_{amb} = 0\text{ °C to }70\text{ °C}$	1221	-	1259	mV
		TLVH431AIDBZR $T_{amb} = -40\text{ °C to }85\text{ °C}$	1215	-	1265	mV
		TLVH431AQDBZR TLVH431AMQDBZR TLVH431AQDBVR $T_{amb} = -40\text{ °C to }125\text{ °C}$	1209	-	1271	mV
ΔV_{ref}	reference voltage variation	$V_{KA} = V_{ref}; I_K = 10\text{ mA}$ $T_{amb} = 0\text{ °C to }70\text{ °C}$	-	2	10	mV
		TLVH431AIDBZR $T_{amb} = -40\text{ °C to }85\text{ °C}$	-	3	10	mV
		TLVH431AQDBZR TLVH431AMQDBZR TLVH431AQDBVR $T_{amb} = -40\text{ °C to }125\text{ °C}$	-	4	10	mV
		$I_K = 10\text{ mA};$ $\Delta V_{KA} = V_{ref}\text{ to }18\text{ V}$	-	-0.5	-1.5	mV/V
I_{ref}	reference current	$I_K = 10\text{ mA};$ $R1 = 10\text{ k}\Omega; R2 = \text{open}$	-	0.19	0.30	μA
ΔI_{ref}	reference current variation	$I_K = 10\text{ mA};$ $R1 = 10\text{ k}\Omega; R2 = \text{open}$ $T_{amb} = 0\text{ °C to }70\text{ °C}$	-	0.03	0.10	μA
		TLVH431AIDBZR $T_{amb} = -40\text{ °C to }85\text{ °C}$	-	0.06	0.16	μA
		TLVH431AQDBZR TLVH431AMQDBZR TLVH431AQDBVR $T_{amb} = -40\text{ °C to }125\text{ °C}$	-	0.07	0.24	μA
		$V_{KA} = V_{ref}$	-	55	80	μA
I_{off}	off-state current	$V_{KA} = 18\text{ V}; V_{ref} = 0$	-	0.01	0.05	μA
Z_{KA}	dynamic cathode-anode impedance	$I_K = 0.1\text{ mA to }70\text{ mA};$ $V_{KA} = V_{ref}; f < 1\text{ kHz}$	-	0.10	0.15	Ω
		SOT23	-	0.15	0.20	Ω
		SOT753	-	0.15	0.20	Ω

Table 10. Characteristics ...continued
 $T_{amb} = 25\text{ °C}$ unless otherwise specified.

Symbol	Parameter	Conditions	Min	Typ	Max	Unit
D-Grade (0.75 %): TLVH431DQDBZR; TLVH431DMQDBZR; TLVH431DQDBVR						
V_{ref}	reference voltage	$V_{KA} = V_{ref}; I_K = 10\text{ mA}$				
		$T_{amb} = 25\text{ °C}$	1231	1240	1249	mV
		$T_{amb} = -40\text{ °C to }125\text{ °C}$	1215	-	1265	mV
ΔV_{ref}	reference voltage variation	$V_{KA} = V_{ref}; I_K = 10\text{ mA}$				
		$T_{amb} = 0\text{ °C to }70\text{ °C}$	-	2	10	mV
		$T_{amb} = -40\text{ °C to }85\text{ °C}$	-	3	10	mV
		$T_{amb} = -40\text{ °C to }125\text{ °C}$	-	4	10	mV
$\Delta V_{ref}/\Delta V_{KA}$	reference voltage variation to cathode-anode voltage variation ratio	$I_K = 10\text{ mA};$ $\Delta V_{KA} = V_{ref}\text{ to }18\text{ V}$	-	-0.5	-1.5	mV/V
I_{ref}	reference current	$I_K = 10\text{ mA};$ $R1 = 10\text{ k}\Omega; R2 = \text{open}$	-	0.19	0.30	μA
ΔI_{ref}	reference current variation	$I_K = 10\text{ mA};$ $R1 = 10\text{ k}\Omega; R2 = \text{open};$ $T_{amb} = -40\text{ °C to }125\text{ °C}$	-	0.07	0.24	μA
$I_{K(min)}$	minimum cathode current	$V_{KA} = V_{ref}$	-	55	80	μA
I_{off}	off-state current	$V_{KA} = 18\text{ V}; V_{ref} = 0$	-	0.01	0.05	μA
Z_{KA}	dynamic cathode-anode impedance	$I_K = 0.1\text{ mA to }70\text{ mA};$ $V_{KA} = V_{ref}; f < 1\text{ kHz}$				
		SOT23	-	0.10	0.15	Ω
		SOT753	-	0.15	0.20	Ω

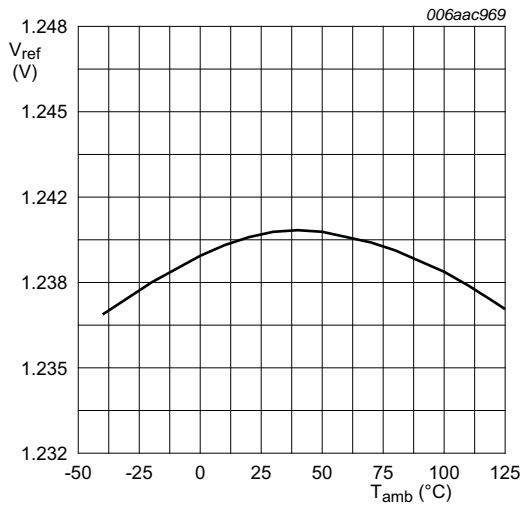

$I_K = 10 \text{ mA}; V_{KA} = V_{ref}$

Fig 4. Reference voltage as a function of ambient temperature; typical values

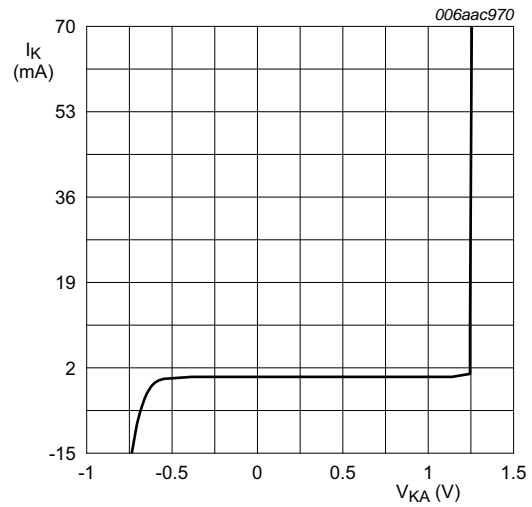

$V_{KA} = V_{ref}; T_{amb} = 25 \text{ °C}$

Fig 5. Cathode current as a function of cathode-anode voltage; typical values

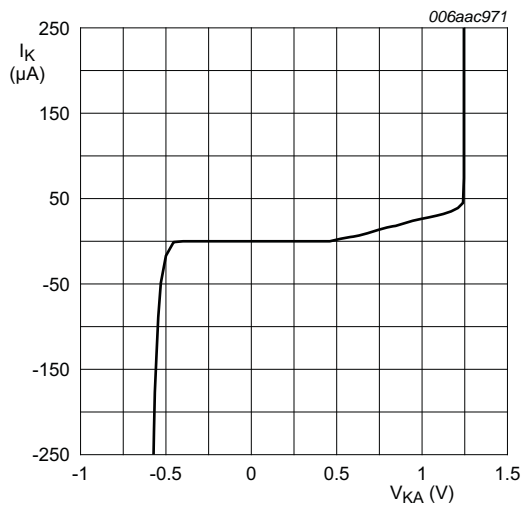

$V_{KA} = V_{ref}; T_{amb} = 25 \text{ °C}$

Fig 6. Cathode current as a function of cathode-anode voltage; typical values

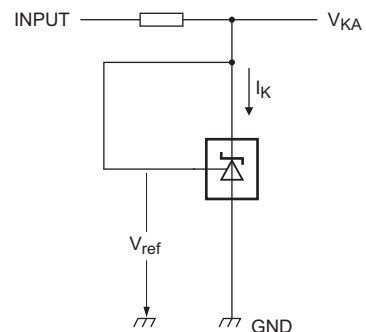

006aac994

$I_K = 10 \text{ mA}; V_{KA} = V_{ref}$

Fig 7. Test circuit to [Figure 4](#), [5](#) and [6](#)

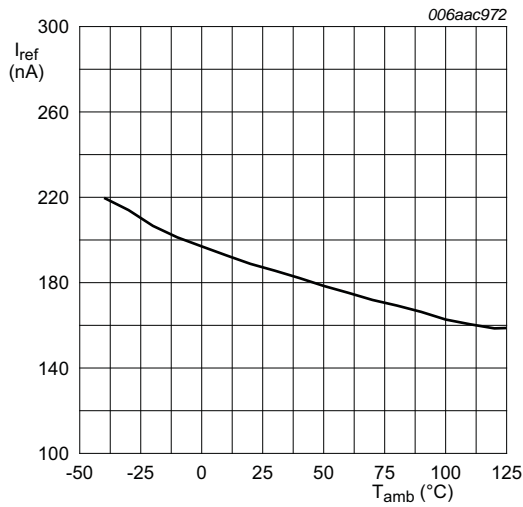

V_{KA} = 1.24 V; I_K = 10 mA; R1 = 10 kΩ; R2 = open

Fig 8. Reference current as a function of ambient temperature; typical values

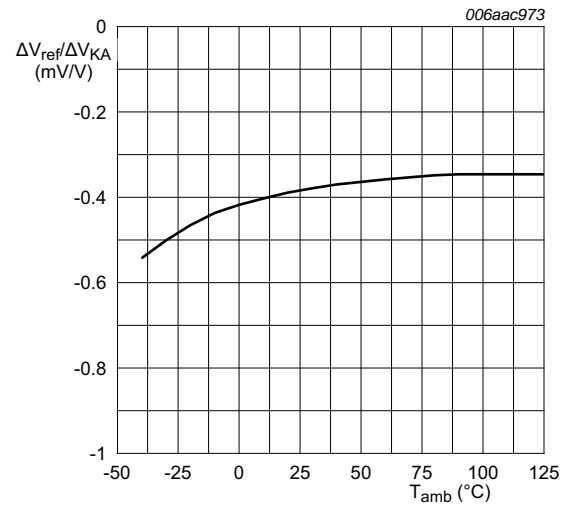

I_K = 10 mA; T_{amb} = 25 °C

Fig 9. Reference voltage variation to cathode-anode voltage variation ratio as a function of ambient temperature; typical values

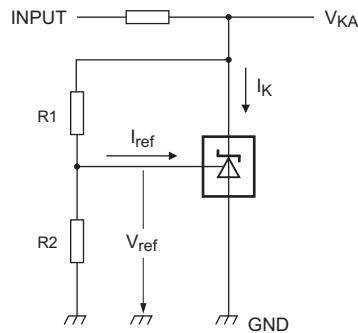

006aac995

$$V_{KA} = V_{ref} \times \left(1 + \frac{R1}{R2} \right) + I_{ref} \times R1$$

Fig 10. Test circuit to [Figure 8](#) and [9](#)

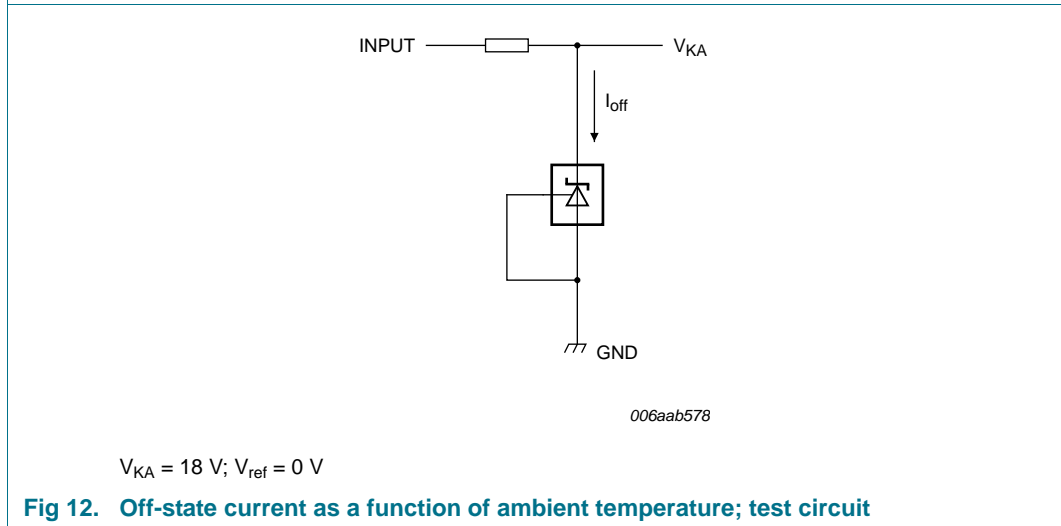
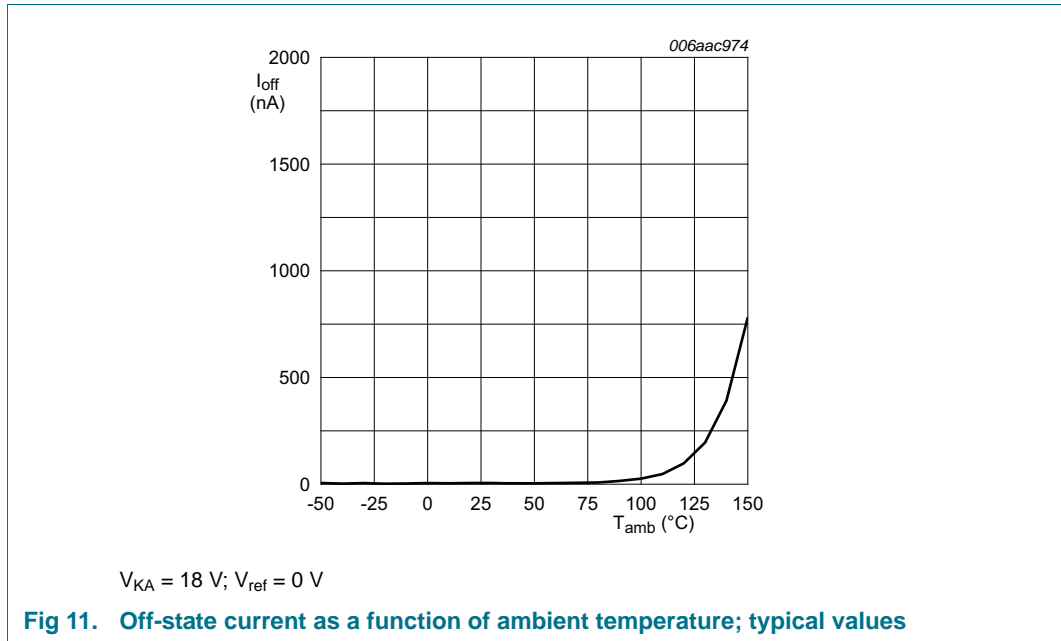

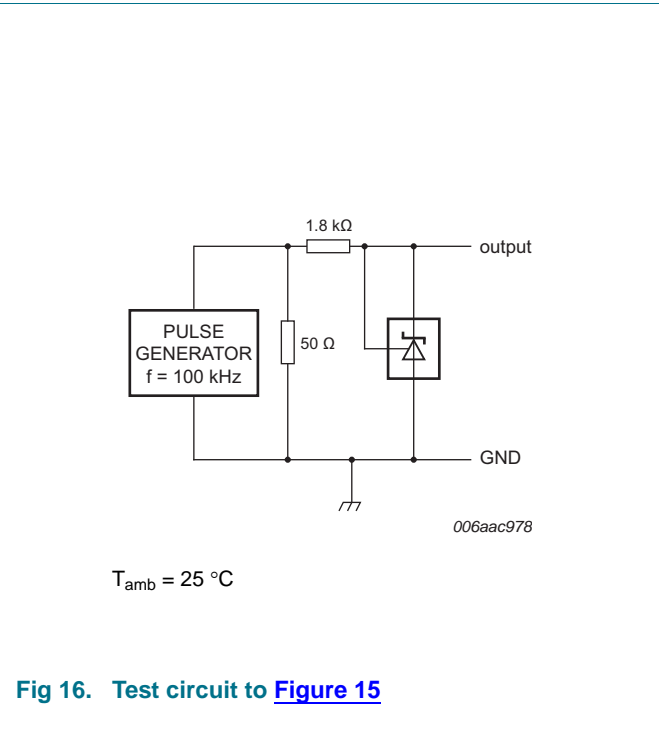
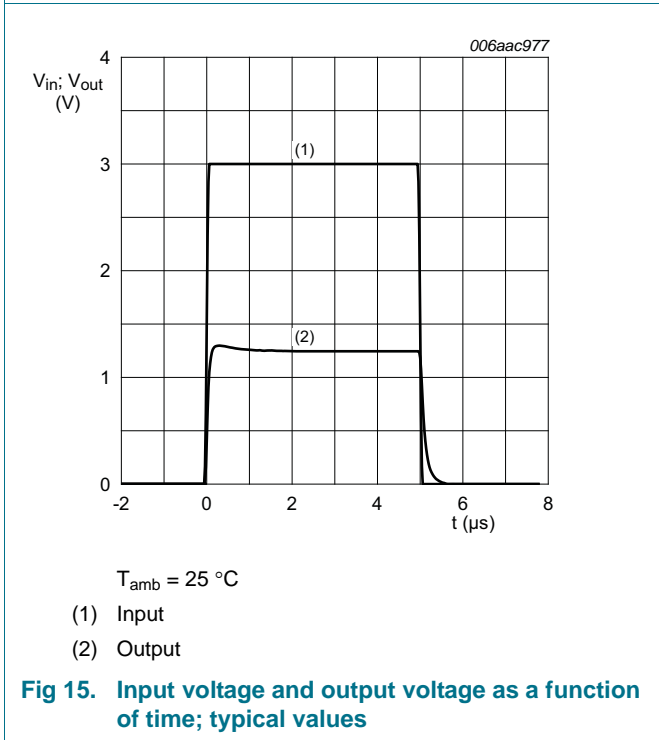
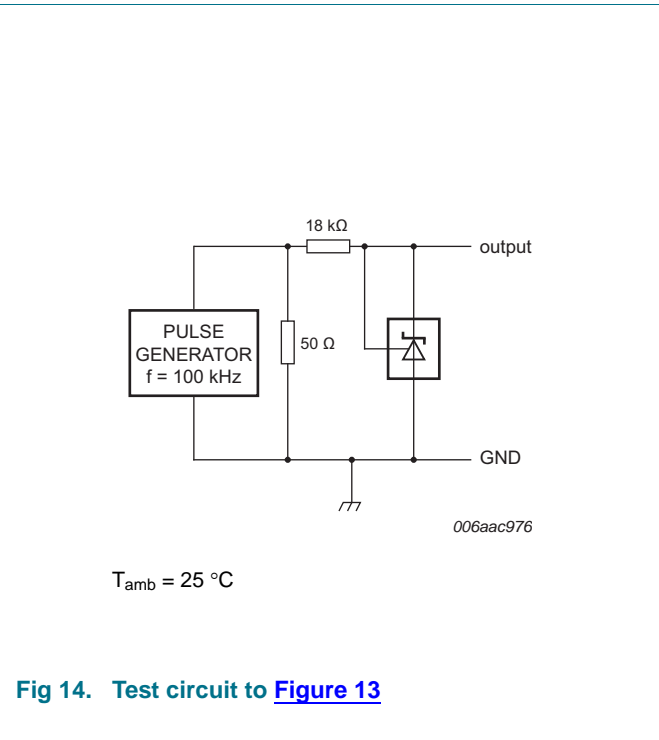
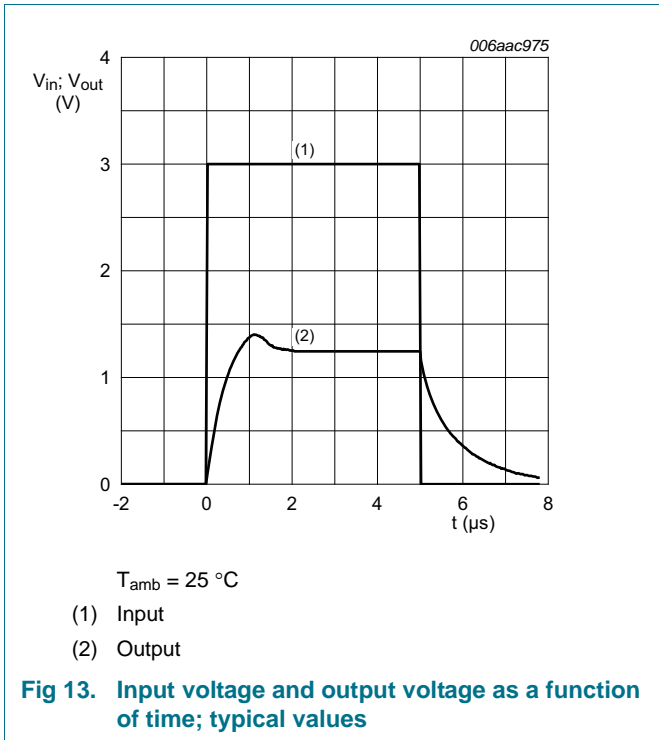

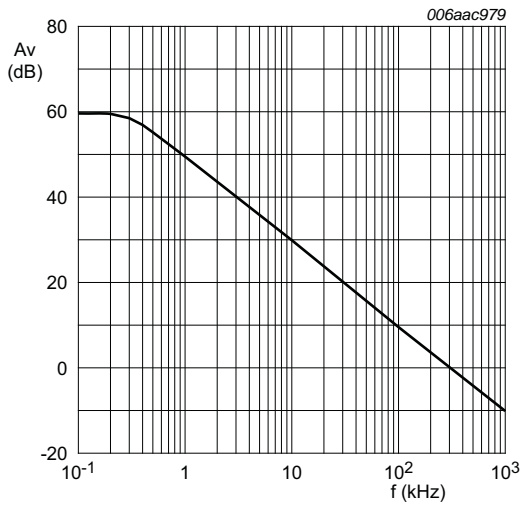

$I_K = 10 \text{ mA}; T_{\text{amb}} = 25 \text{ }^\circ\text{C}$

Fig 17. Voltage amplification as a function of frequency; typical values

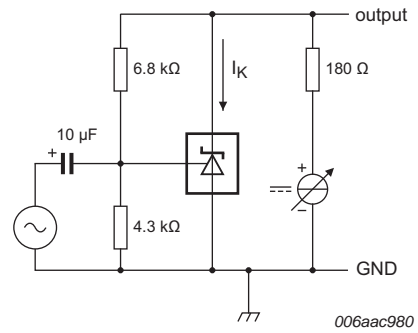

$I_K = 10 \text{ mA}; T_{\text{amb}} = 25 \text{ }^\circ\text{C}$

Fig 18. Test circuit to Figure 17

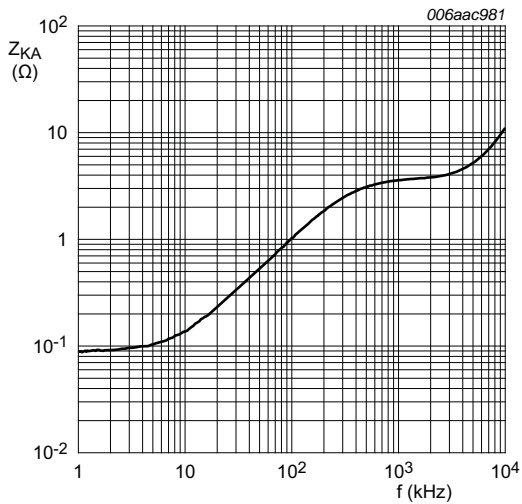

$I_K = 10 \text{ mA}; T_{\text{amb}} = 25 \text{ }^\circ\text{C}$

Fig 19. Dynamic cathode-anode impedance as a function of frequency; typical values

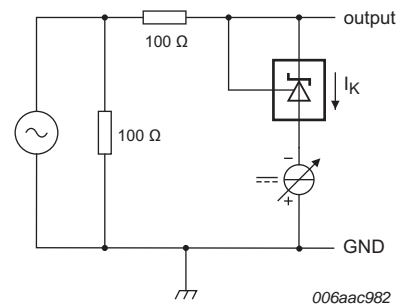

$I_K = 10 \text{ mA}; T_{\text{amb}} = 25 \text{ }^\circ\text{C}$

Fig 20. Test circuit to Figure 19

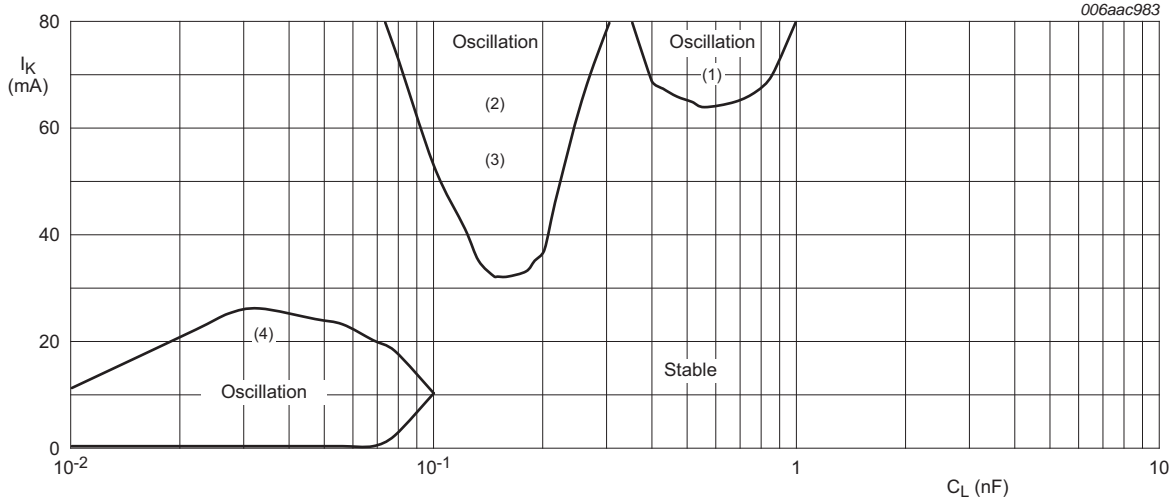

- $T_{amb} = 25\text{ }^{\circ}\text{C}$
- (1) $V_{KA} = V_{ref}$
 - (2) $V_{KA} = 2\text{ V}$
 - (3) $V_{KA} = 3\text{ V}$
 - (4) $V_{KA} = 18\text{ V}$

Fig 21. Cathode current as a function of load capacitance; typical values

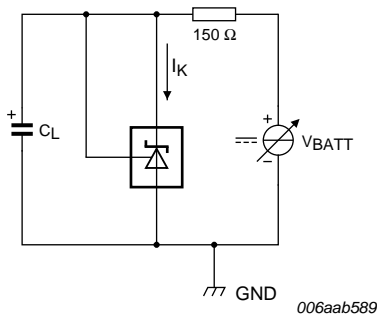

- $V_{KA} = V_{ref}$
- $T_{amb} = 25\text{ }^{\circ}\text{C}$

Fig 22. Test circuit to Figure 21

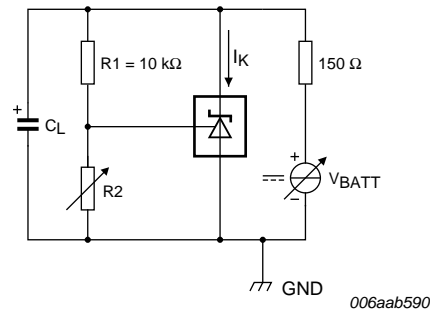

- $V_{KA} > V_{ref}$
- $T_{amb} = 25\text{ }^{\circ}\text{C}$

Fig 23. Test circuit to Figure 21

Figure 21, 22 and 23 show the stability boundaries and test circuits for the worst case conditions with a load capacitance mounted as close as possible to the device. The required load capacitance for stable operation varies depending on the operating temperature and capacitor Equivalent Series Resistance (ESR). Verify that the application circuit is stable over the anticipated operating current and temperature ranges.

13. Application information

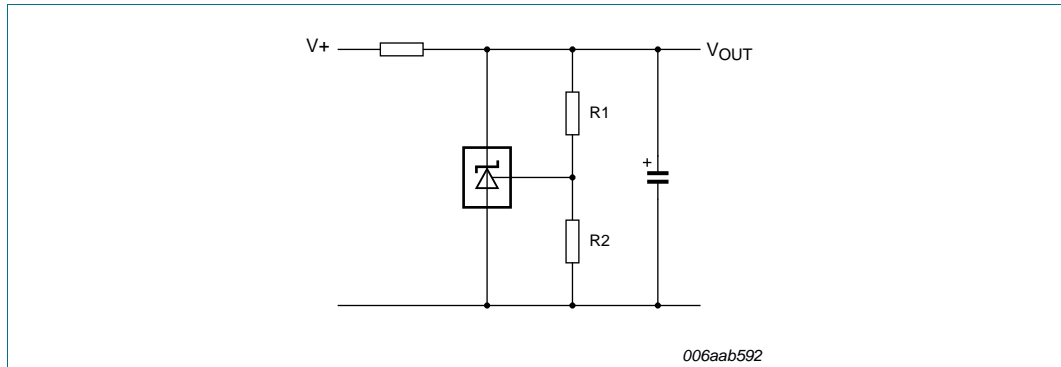

$$V_{OUT} = \left(1 + \frac{R1}{R2}\right) \times V_{ref}$$

Fig 24. Shunt regulator

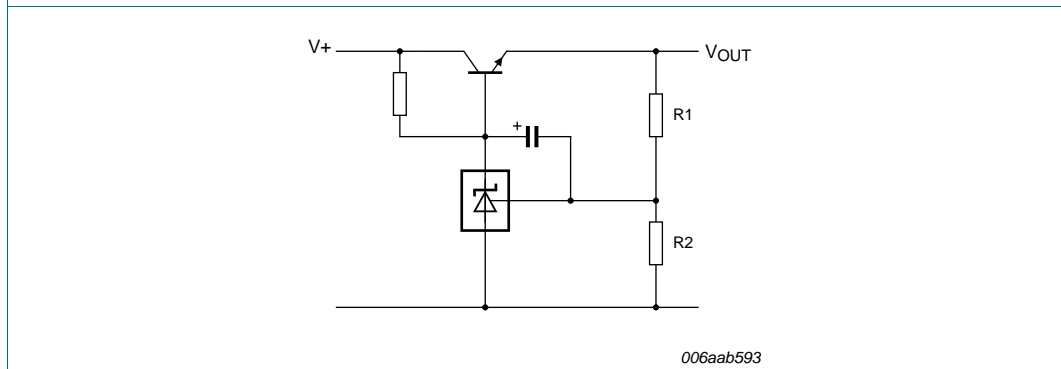

$$V_{OUT} = \left(1 + \frac{R1}{R2}\right) \times V_{ref}; V_{OUT(min)} = V_{ref} + V_{be}$$

Fig 25. Series pass regulator

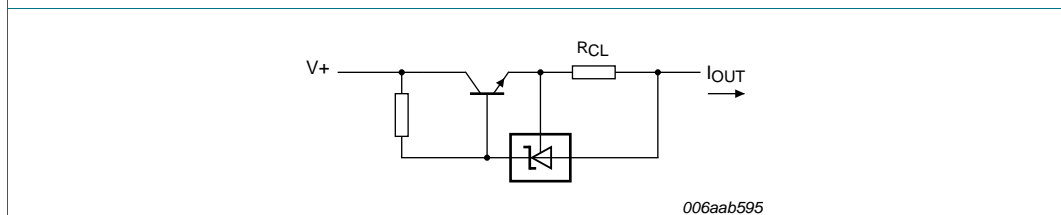

$$I_{OUT} = \frac{V_{ref}}{R_{CL}}$$

Fig 26. Constant current source

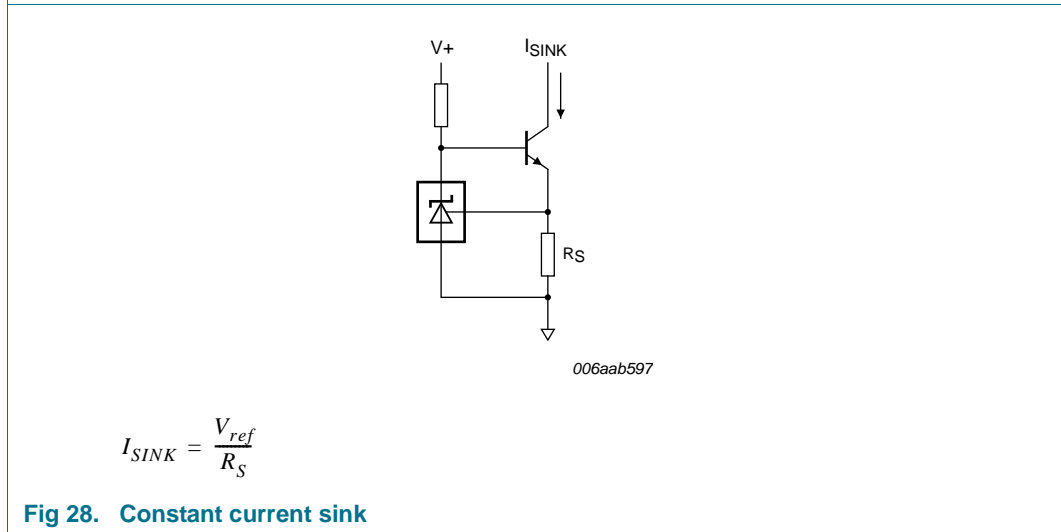
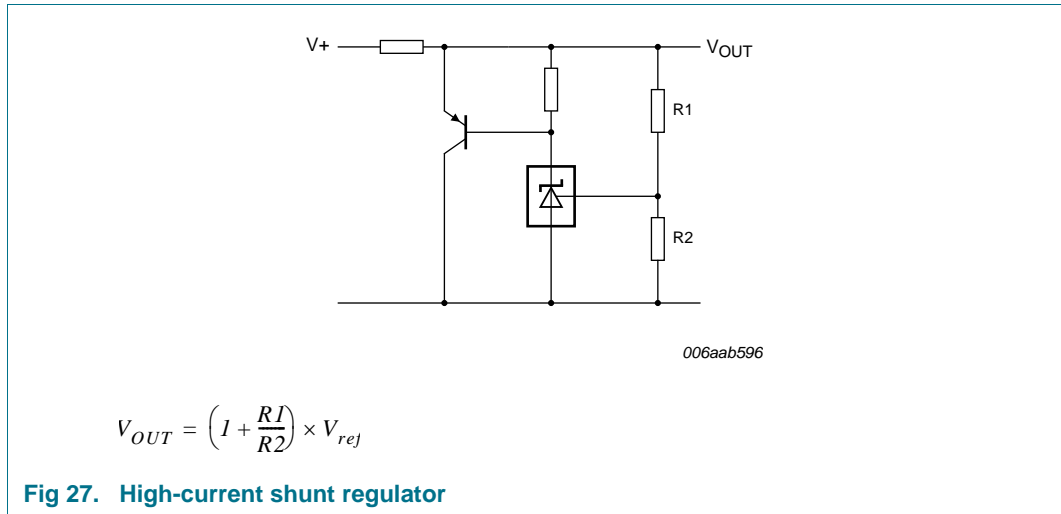

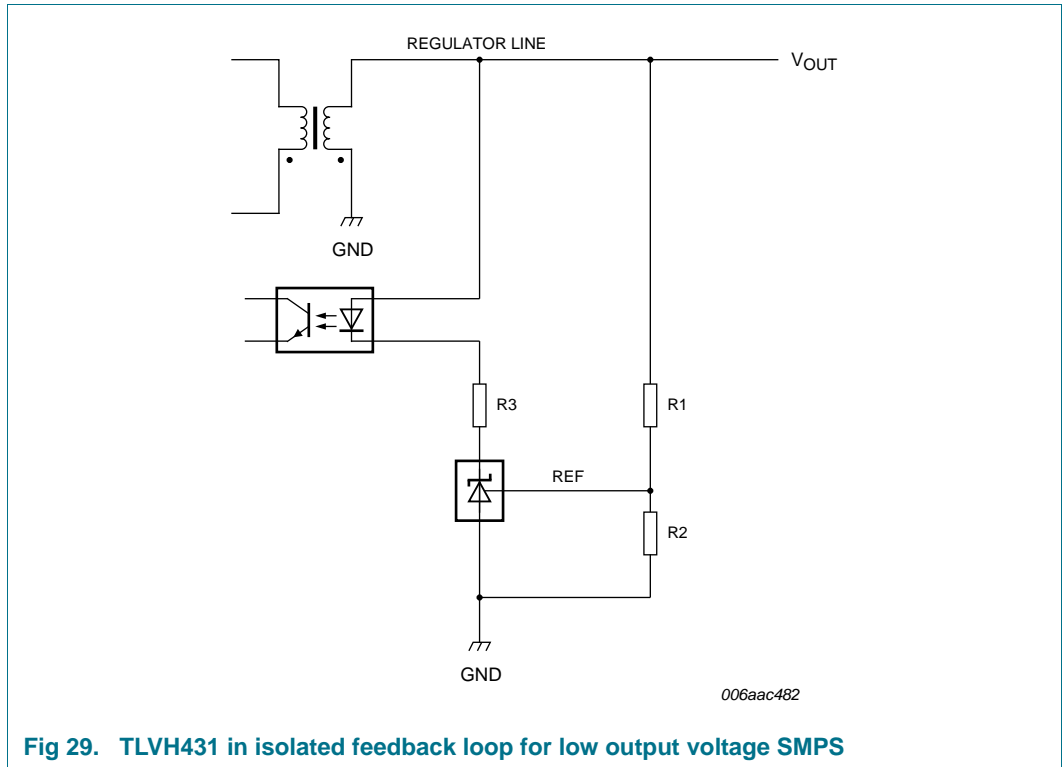

Fig 29. TLVH431 in isolated feedback loop for low output voltage SMPS

14. Test information

14.1 Quality information

This product has been qualified in accordance with the Automotive Electronics Council (AEC) standard *Q100 - Failure mechanism based stress test qualification for integrated circuits*, and is suitable for use in automotive applications.

15. Package outline

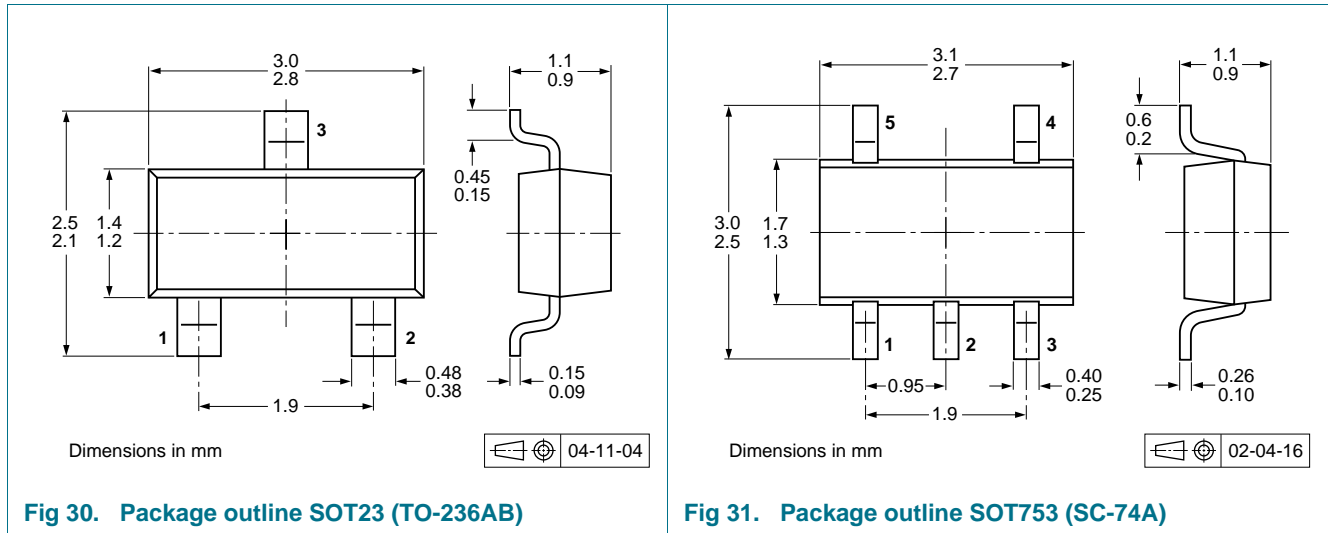

16. Packing information

Table 11. Packing methods

The indicated -xxx are the last three digits of the 12NC ordering code.^[1]

Type number	Package	Description	Packing quantity	
			3000	10000
TLVH431XBZR	SOT23	4 mm pitch, 8 mm tape and reel	-215	-235
TLVH431XBVR	SOT753	4 mm pitch, 8 mm tape and reel	-115	-

[1] For further information and the availability of packing methods, see [Section 20](#).

17. Soldering

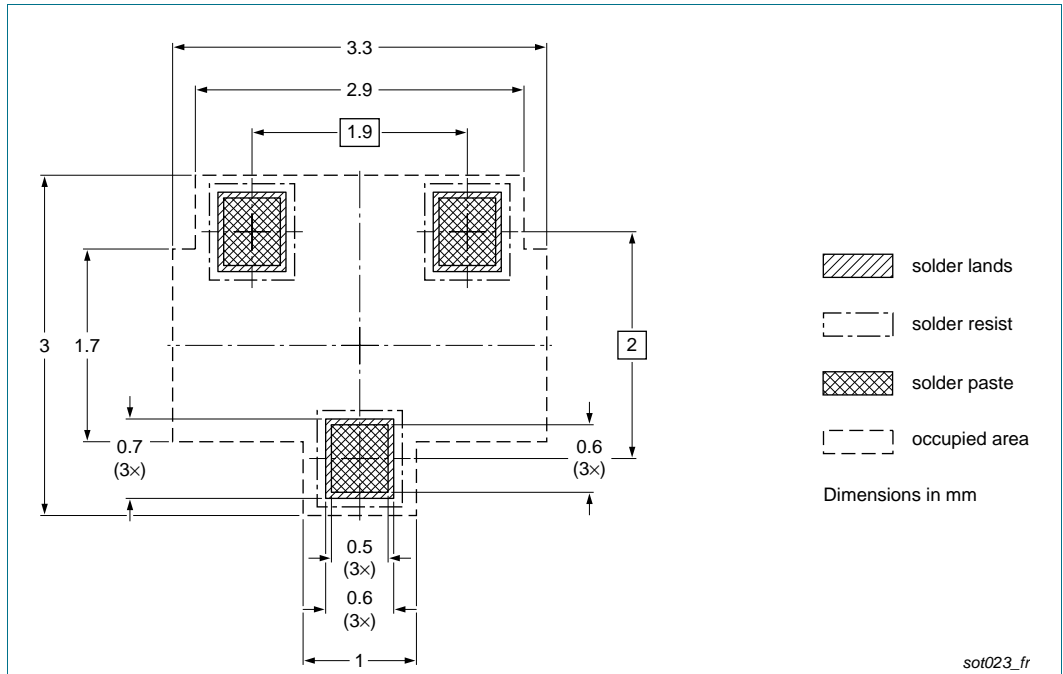

Fig 32. Reflow soldering footprint SOT23 (TO-236AB)

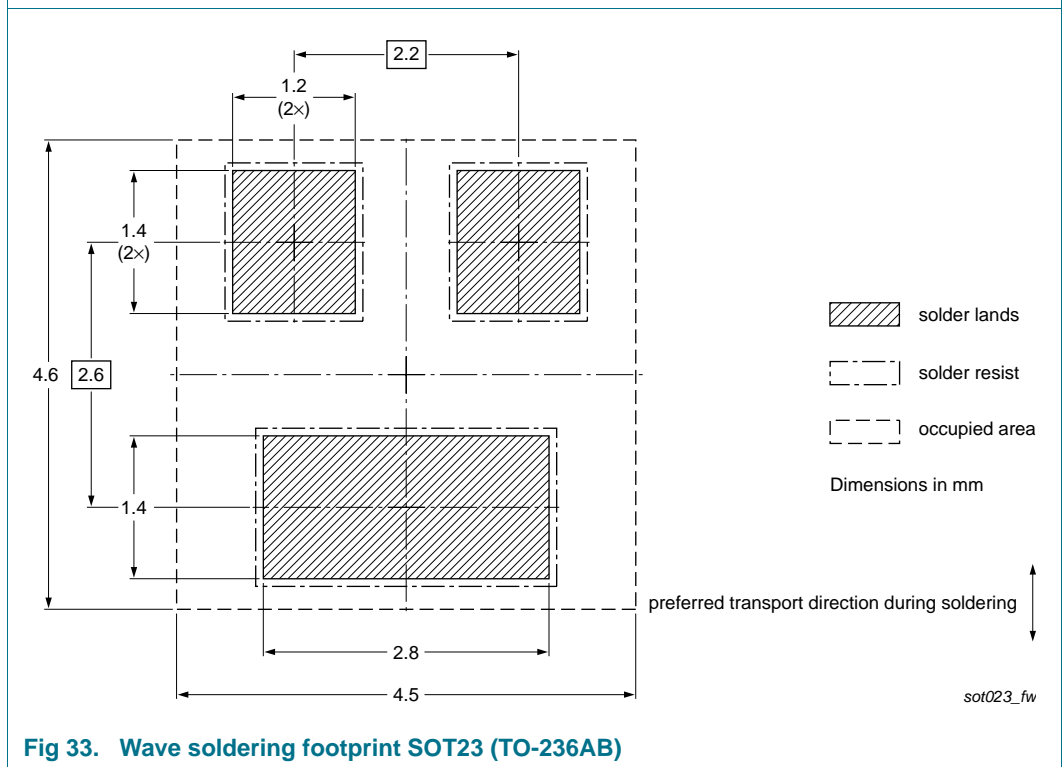

Fig 33. Wave soldering footprint SOT23 (TO-236AB)

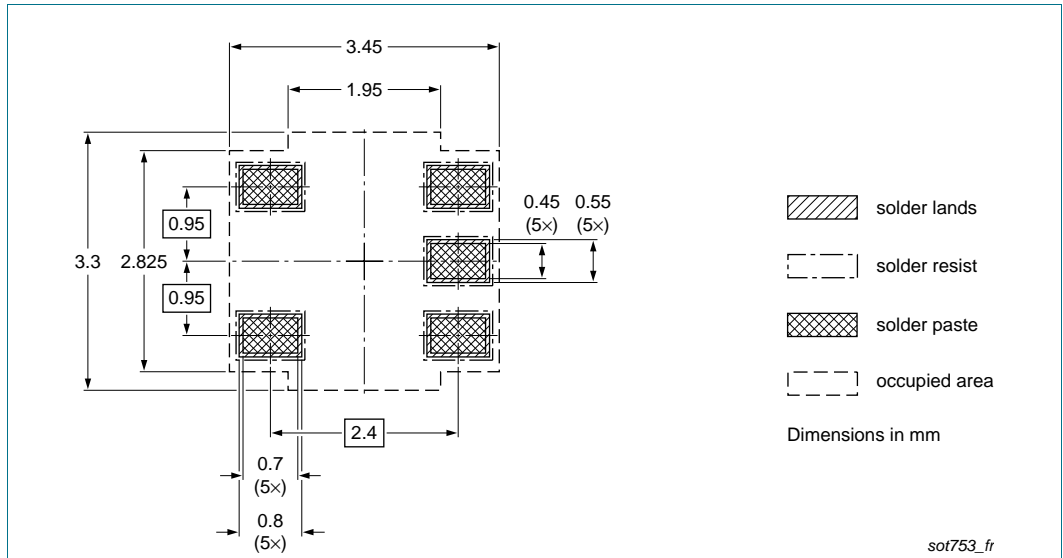

Fig 34. Reflow soldering footprint SOT753 (SC-74A)

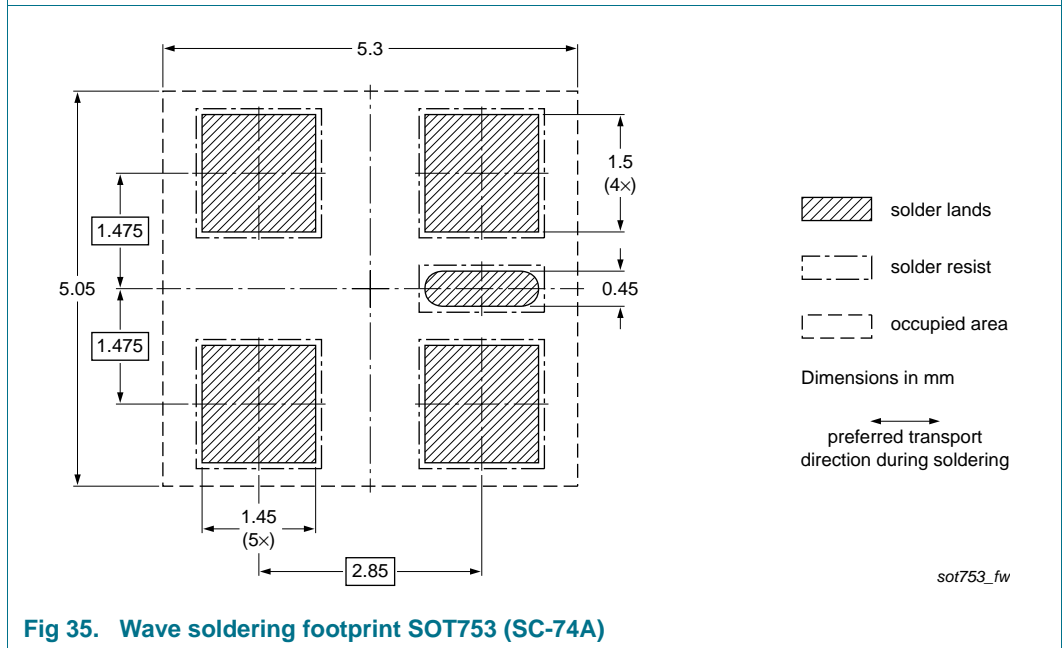

Fig 35. Wave soldering footprint SOT753 (SC-74A)

18. Revision history

Table 12. Revision history

Document ID	Release date	Data sheet status	Change notice	Supersedes
TLVH431_FAM v.1	20120427	Product data sheet	-	-

19. Legal information

19.1 Data sheet status

Document status ^{[1][2]}	Product status ^[3]	Definition
Objective [short] data sheet	Development	This document contains data from the objective specification for product development.
Preliminary [short] data sheet	Qualification	This document contains data from the preliminary specification.
Product [short] data sheet	Production	This document contains the product specification.

[1] Please consult the most recently issued document before initiating or completing a design.

[2] The term 'short data sheet' is explained in section "Definitions".

[3] The product status of device(s) described in this document may have changed since this document was published and may differ in case of multiple devices. The latest product status information is available on the Internet at URL <http://www.nxp.com>.

19.2 Definitions

Draft — The document is a draft version only. The content is still under internal review and subject to formal approval, which may result in modifications or additions. NXP Semiconductors does not give any representations or warranties as to the accuracy or completeness of information included herein and shall have no liability for the consequences of use of such information.

Short data sheet — A short data sheet is an extract from a full data sheet with the same product type number(s) and title. A short data sheet is intended for quick reference only and should not be relied upon to contain detailed and full information. For detailed and full information see the relevant full data sheet, which is available on request via the local NXP Semiconductors sales office. In case of any inconsistency or conflict with the short data sheet, the full data sheet shall prevail.

Product specification — The information and data provided in a Product data sheet shall define the specification of the product as agreed between NXP Semiconductors and its customer, unless NXP Semiconductors and customer have explicitly agreed otherwise in writing. In no event however, shall an agreement be valid in which the NXP Semiconductors product is deemed to offer functions and qualities beyond those described in the Product data sheet.

19.3 Disclaimers

Limited warranty and liability — Information in this document is believed to be accurate and reliable. However, NXP Semiconductors does not give any representations or warranties, expressed or implied, as to the accuracy or completeness of such information and shall have no liability for the consequences of use of such information. NXP Semiconductors takes no responsibility for the content in this document if provided by an information source outside of NXP Semiconductors.

In no event shall NXP Semiconductors be liable for any indirect, incidental, punitive, special or consequential damages (including - without limitation - lost profits, lost savings, business interruption, costs related to the removal or replacement of any products or rework charges) whether or not such damages are based on tort (including negligence), warranty, breach of contract or any other legal theory.

Notwithstanding any damages that customer might incur for any reason whatsoever, NXP Semiconductors' aggregate and cumulative liability towards customer for the products described herein shall be limited in accordance with the *Terms and conditions of commercial sale* of NXP Semiconductors.

Right to make changes — NXP Semiconductors reserves the right to make changes to information published in this document, including without limitation specifications and product descriptions, at any time and without notice. This document supersedes and replaces all information supplied prior to the publication hereof.

Suitability for use — NXP Semiconductors products are not designed, authorized or warranted to be suitable for use in life support, life-critical or safety-critical systems or equipment, nor in applications where failure or malfunction of an NXP Semiconductors product can reasonably be expected to result in personal injury, death or severe property or environmental damage. NXP Semiconductors and its suppliers accept no liability for inclusion and/or use of NXP Semiconductors products in such equipment or applications and therefore such inclusion and/or use is at the customer's own risk.

Applications — Applications that are described herein for any of these products are for illustrative purposes only. NXP Semiconductors makes no representation or warranty that such applications will be suitable for the specified use without further testing or modification.

Customers are responsible for the design and operation of their applications and products using NXP Semiconductors products, and NXP Semiconductors accepts no liability for any assistance with applications or customer product design. It is customer's sole responsibility to determine whether the NXP Semiconductors product is suitable and fit for the customer's applications and products planned, as well as for the planned application and use of customer's third party customer(s). Customers should provide appropriate design and operating safeguards to minimize the risks associated with their applications and products.

NXP Semiconductors does not accept any liability related to any default, damage, costs or problem which is based on any weakness or default in the customer's applications or products, or the application or use by customer's third party customer(s). Customer is responsible for doing all necessary testing for the customer's applications and products using NXP Semiconductors products in order to avoid a default of the applications and the products or of the application or use by customer's third party customer(s). NXP does not accept any liability in this respect.

Limiting values — Stress above one or more limiting values (as defined in the Absolute Maximum Ratings System of IEC 60134) will cause permanent damage to the device. Limiting values are stress ratings only and (proper) operation of the device at these or any other conditions above those given in the Recommended operating conditions section (if present) or the Characteristics sections of this document is not warranted. Constant or repeated exposure to limiting values will permanently and irreversibly affect the quality and reliability of the device.

Terms and conditions of commercial sale — NXP Semiconductors products are sold subject to the general terms and conditions of commercial sale, as published at <http://www.nxp.com/profile/terms>, unless otherwise agreed in a valid written individual agreement. In case an individual agreement is concluded only the terms and conditions of the respective agreement shall apply. NXP Semiconductors hereby expressly objects to applying the customer's general terms and conditions with regard to the purchase of NXP Semiconductors products by customer.

No offer to sell or license — Nothing in this document may be interpreted or construed as an offer to sell products that is open for acceptance or the grant, conveyance or implication of any license under any copyrights, patents or other industrial or intellectual property rights.

Export control — This document as well as the item(s) described herein may be subject to export control regulations. Export might require a prior authorization from competent authorities.

Quick reference data — The Quick reference data is an extract of the product data given in the Limiting values and Characteristics sections of this document, and as such is not complete, exhaustive or legally binding.

19.4 Trademarks

Notice: All referenced brands, product names, service names and trademarks are the property of their respective owners.

20. Contact information

For more information, please visit: <http://www.nxp.com>

For sales office addresses, please send an email to: salesaddresses@nxp.com

21. Contents

1	General description	1
2	Features and benefits	1
3	Applications	1
4	Quick reference data	2
5	Ordering information	2
6	Marking	2
7	Functional diagram	3
8	Pinning information	3
9	Limiting values	4
10	Recommended operating conditions	5
11	Thermal characteristics	6
12	Characteristics	7
13	Application information	16
14	Test information	18
14.1	Quality information	18
15	Package outline	19
16	Packing information	19
17	Soldering	20
18	Revision history	22
19	Legal information	23
19.1	Data sheet status	23
19.2	Definitions	23
19.3	Disclaimers	23
19.4	Trademarks	24
20	Contact information	24
21	Contents	25

Please be aware that important notices concerning this document and the product(s) described herein, have been included in section 'Legal information'.

© NXP B.V. 2012.

All rights reserved.

For more information, please visit: <http://www.nxp.com>

For sales office addresses, please send an email to: salesaddresses@nxp.com

Date of release: 27 April 2012

Document identifier: TLVH431_FAM

Looking for pricing, stock, or lifecycle information?

Click below to explore more details on WIN SOURCE:

- ⊖ [View TLVH431DQDBVR,125 on WIN SOURCE](#)
- ⊖ [NXP / Nexperia Information](#)

Optimize Your Supply Chain with WIN SOURCE Solutions

- ✓ Global Sourcing Solution
- ✓ Obsolete Management
- ✓ Cost Control Management
- ✓ Shortage Management
- ✓ Alternative Solution
- ✓ Excess Inventory Management